

# INDEX

## SYMBOLS

4 WAY PENETRANT . . . 401

## A

### ABRASIVES

Aluminum Grinding . . . 354  
Chop Saw . . . 356  
Crocus Cloth . . . 358  
Cupstones . . . 354  
Cut-Off Wheels . . . 355, 356  
Depressed Center Wheels . . . 353  
Emery Cloth . . . 358  
Fiber Discs . . . 360  
Flap Discs . . . 361  
Flap Wheels . . . 360  
Flaring Cupstones . . . 354  
Flex Grinding Wheels . . . 354  
FlexFinish Discs . . . 362  
Grinding Discs . . . 353  
Hand Pads . . . 362  
Masonry  
    Cut-Off Wheels . . . 356  
    Grinding Wheels . . . 353  
Metal Grinding . . . 353  
Mounted Points . . . 356  
Quick-Lok Discs . . . 359  
Resin Fiber Discs . . . 360  
Roloc Type Discs . . . 362  
Sanding Screen . . . 358  
Screen-Bak . . . 358  
Shop Rolls . . . 358  
Surface Conditioning Discs . . . 362  
Trim-Kut® Discs . . . 359  
Utility Rolls . . . 358  
Zirconia Grinding Wheels . . . 353

### ABSORBENT (OIL DRY) . . . 384

### AC SENSOR . . . 177

### ACCESSORY BOLTS . . . 192

### ACETYLENE . . . 415

Fittings . . . 415  
Flashback Arrestors . . . 415  
Quick Disconnects . . . 415  
Torch Tips . . . 416  
Welding Hose . . . 415

### ACID BRUSHES . . . 367

### ACID CLEANER . . . 377

### ACME THREADED ROD . . . 63

### ADAPTERS

"A" Taper Drill Bit . . . 336  
Bench Grinding Wheel . . . 357  
Cut-Off Wheel . . . 355, 356  
Garden Hose Fitting . . . 279  
Grease Gun . . . 305  
Hydraulic . . . 294, 295  
Needle Nose . . . 305  
Threaded Arbor Reducing . . . 365  
Trim Kut Disc . . . 359  
Wire Wheel . . . 363

### ADHESIVES

Anaerobics . . . 374  
Black Max® . . . 371  
Cyanoacrylate . . . 371  
Epoxies . . . 372  
Hi-Tack . . . 391  
Instant . . . 371  
J-B Weld . . . 372  
Magic Metal . . . 372  
Prism . . . 371  
RTV Silicone . . . 392  
Spray . . . 373  
Super Bonder® . . . 371  
Weatherstrip . . . 371

### AIR BRAKE

Diaphragms (Pancakes) . . . 260  
Fittings  
    Copper Tube . . . 231  
    Hose, Type B . . . 259  
    Nylon (NTA) . . . 233  
    Push-In . . . 239, 240  
Glad Hands . . . 260  
Hose Assemblies . . . 205, 215

Hose, Type B . . . 215  
Tubing, Nylon . . . 215  
**AIR CHUCKS . . . 206**  
    Quick Disconnect . . . 261, 266

### AIR COCKS, BRASS . . . 249

### AIR COUPLERS

Quarter Turn . . . 281  
Quick Disconnect . . . 261  
Straight Thru . . . 266

### AIR GAUGE . . . 273

### AIR HOSE

Caddy . . . 439  
Crimper . . . 279  
Fittings. *See* Fittings  
Push On . . . 212  
Rubber . . . 211  
Self-Storing . . . 212

### AIR LINE

Filters . . . 272  
Lubricators . . . 272  
Manifold . . . 274  
Pressure Gauges . . . 273  
Regulators . . . 272

### AIR NOZZLE . . . 438

### AIR NOZZLE ATTACHMENTS . . . 438

### AIR TANK POP-OFF VALVES . . . 251, 274

### AIR TOOL OIL . . . 398

### AIRCRAFT CABLE . . . 312

### AKRO BINS . . . 482

### ALIGNMENT PUNCHES . . . 442

### ALL PURPOSE SILICONE . . . 403

### ALL-THREAD (ROD) . . . 60, 63

### ALLIGATOR CLIPS . . . 197

### ALLOY CHAIN LINKS . . . 321

### ALLOYS, WELDING . . . 412, 414

### ALUMINARC WELDING ROD . . . 414

### ALUMINUM

Acid Cleaner . . . 377  
Polish/Cleaner . . . 384

### ALUMINUM GRINDING WHEELS . . . 354

### ANAEROBIC ADHESIVES . . . 374

### ANCHOR BOLTS . . . 42

### ANCHORS

Ackerman-Johnson type . . . 42  
Caulking . . . 42  
Cinder Block . . . 47  
Concrete Screw . . . 43  
Drive type . . . 44  
Drywall . . . 46  
Expansion Shield (double) . . . 42  
Hollow Wall . . . 46  
Kap-Toggle . . . 47  
Lag Screw Shield . . . 44  
Lead Machine Screw . . . 42  
Machine Bolt . . . 42  
Molly . . . 46  
Nail . . . 44  
Plastic Screw . . . 45  
Self-Drilling Wallboard . . . 46  
Stud . . . 41  
Tap-Con type . . . 43  
Tap-It . . . 44  
Toggle Bolts/Wings . . . 47  
Togglers . . . 45  
Vinyl Screw . . . 46  
Wallboard . . . 46  
Wedge . . . 41  
Wej-it . . . 41  
Zip-Toggle . . . 47

### ANDERSON CONNECTORS . . . 193

### ANTI-CORROSION WASHERS . . . 385

### ANTI-FREEZE

Gas Line . . . 405  
Windshield Washer . . . 406

### ANTI-SEIZE LUBRICANT . . . 395

### ANTI-SPATTER . . . 385

### ARBORS

Cut Off Wheel . . . 355, 366  
Hole Saw . . . 352  
Roloc Style . . . 362  
Wire Wheel Brush . . . 363, 365

### ARC WELDING RODS . . . 412

### ASSORTMENT INDEX . . .

473, 474, 475, 476

### ASSORTMENTS/KITS

Battery Terminal . . . 187  
Blind Rivets . . . 48  
Burs, Carbide . . . 337  
Cable Ties . . . 174  
Cap Screws, Stainless Steel . . . 104  
Cap Screws, Steel . . . 16  
Car Reamers . . . 332  
Carbide Burs . . . 337

Castle Nuts . . . 94  
Clamps . . . 219  
Clevis Pin . . . 141  
Clevis Pins . . . 141  
Concrete Screw Tool Kit . . . 43  
Concrete Screws . . . 43  
Cotter Pin . . . 135  
Drill Set, 1/2" Shank . . . 331  
Drill Set, 1/2" Shank Brute . . . 332  
Drill Set, 3/8" Shank . . . 330  
Drill Set, Aircraft . . . 325  
Drill Set, Brute . . . 326  
Drill Set, Cobalt . . . 327  
Drill Set, Left Hand . . . 333  
Drill Set, Letter Gauge . . . 328  
Drill Set, LH with Extractors . . . 334  
Drill Set, Sheeters . . . 333  
Drill Set, Wire Gauge . . . 328  
Drywall & Deck Screws . . . 74  
E-Z Lok Inserts . . . 56  
Extra Thick Flats . . . 98  
Ferules, Air Hose . . . 279  
Fittings

Airbrake for Copper . . . 232

Airbrake, NTA . . . 234

Compression . . . 228

Flare . . . 237

Grease . . . 304

Hydraulic Hose . . . 293

Instant push-in . . . 240, 241

Inverted Flare . . . 230

Parker Hose Ends . . . 293

Pipe (brass) . . . 246

Pipe (iron) . . . 258

Pipe Hex Nipples (brass) . . . 247

Pipe Nipples (brass) . . . 248

push-in (Acetal) . . . 241

push-in (brass) . . . 240

push-on couplings . . . 283

### Fuses, Automotive . . . 200

Grade C Lock Nuts . . . 91

Hairpin Cotter . . . 136

Heat Shrink Tubing . . . 183

Hex Nuts . . . 89

Hole Saw Sets . . . 352

Hose Clamps . . . 219

Hose Ferrules . . . 279

Jet Plugs . . . 46

Kept® Nuts . . . 92

Key Stock . . . 147

Lock Nuts, Gr C . . . 91

Lock Nuts, Nylon . . . 92

Lock Washers, Star . . . 102

Machine Screws . . . 68, 69, 70

Machine Screws, Brass . . . 115

Machine Screws, S/S . . . 110

Machinery Keys . . . 147

Metric Bolts . . . 121

Metric Flat Socket C/S . . . 124

Metric Grease Fittings . . . 131

Metric Hex Nuts . . . 127

Metric Machine Screws . . . 130

Metric 'O' Rings . . . 131

Metric Socket C/S . . . 123

Metric Socket Set Screws . . . 125

Nutsert Tool Kit . . . 58

O-Ring . . . 151

OEM Trim Screws . . . 79

Pan Hd. SMS . . . 78

Plastic Anchors . . . 45

Reciprocating Saw Blades . . . 348

Retaining Ring . . . 143, 144, 145

Rivets . . . 48

Screw Extractors w/drills . . . 334

Self-Drilling Screws . . . 86

Shakeproof Washers . . . 102

Sheet Metal, One-Way . . . 83

Sheet Metal, Oval . . . 81

Sheet Metal, Pan . . . 78

Sheet Metal Screws, Hex Hd . . . 84

Sheet Metal Screws, Hex Washer Hd . . . 85

Shrink Tubing . . . 183

Slotted Hex Nuts . . . 94

Socket Screws . . . 28

Spiral Pin . . . 139

Spring Pins . . . 139

Tamperproof Screws . . . 83

Tap & Die Sets . . . 342

Tap-Drill Sets . . . 342

Tapping Screws, S/S . . . 111

Tek® Screws . . . 86

Terminals . . . 165

Terminals, ElektraLink . . . 162  
Terminals, Posi-Lock . . . 162  
Thread Cutting, Hex . . . 73  
Thread Repair Inserts . . . 52, 54  
Tie-Straps (nylon) . . . 174  
Wallboard Anchors . . . 46  
Wing Nuts . . . 96  
Wire Nuts . . . 168  
Wood Screw, Flat . . . 76  
Wood Screws, Flat Hd. . . . 76  
Woodruff Keys . . . 146

### AUTO-DARKENING WELDING HELMETS . . . 421

### AUTO-ELECTRIC SEALING COMPOUND . . . 173, 464

### AUTOMATIC WIRE STRIPPER . . . 181, 435

### AUTOMATICCENTER PUNCH . . . 450

### AVIATION GASKET SEALANT . . . 391

### AVIATION SNIPS . . . 432

## B

### BACK SUPPORT BELTS . . . 427

### BACK UP PAD

Flex Wheel . . . 354  
Resin Fiber Disc . . . 360

### BACK UP WASHERS, RIVET . . . 50

### BALING WIRE . . . 170

### BALL FOOT CHUCKS . . . 206

### BALL TIP MARKERS . . . 389, 418

### BALL VALVES . . . 251

### BAND SAW BLADES . . . 350

### BAR STOCK . . . 63

### BARB FITTINGS. *SEE* FITTINGS

### BARREL

Faucets . . . 409  
Pumps & Siphons . . . 408

### BATHROOM CLEANER . . . 378

### BATTERIES, FLASHLIGHT . . . 186

### BATTERY

Accessory Bolts . . . 192  
Anti-Corrosion Washers . . . 196, 385  
Bolts . . . 192  
Booster Cables . . . 197  
Cable . . . 195  
    Butt Splices . . . 191  
    Crimper . . . 195  
    Lug . . . 191  
Charger Connectors . . . 193  
Cleaner . . . 196, 384  
Hold-Downs . . . 192  
Nuts . . . 192  
Nuts, Stud-Top . . . 188  
Slugs . . . 194  
Starter Lugs . . . 191  
Terminal

Adapters . . . 192  
Brush . . . 196  
Crimping Tools . . . 195  
Gauge . . . 448  
Lugs, Compression . . . 189  
Lugs, Heavy Duty . . . 191  
Nuts . . . 188, 192  
Washers . . . 385

Terminals . . . 189, 190

Compression . . . 189

Crimp/Solder Type . . . 188

Emergency . . . 190

Fork Lift . . . 193

Marine . . . 190

Military Style . . . 190

Quick Disconnect . . . 193

Retro-Fit . . . 188

Safe-Mate . . . 193

Side Mount . . . 190

Top Mount . . . 188

Truck . . . 190

### BATTERY TERMINALS . . . 187

FusionTM . . . 187

### BEARING SEPARATORS . . . 446

### BELT DRESSING . . . 386

### BELTS, BACK SUPPORT . . . 427

### BENCH BRUSHES . . . 368

### BEND PROTECTORS, HOSE . . . 211

### BENT PULL PINS . . . 318

### BIG RIG PAINTS . . . 388

### BINDERS, LOAD (CHAIN) . . . 311

### BINS

Corrugated . . . 482  
Plastic (Akro style) . . . 482  
Steel Storage . . . 477, 481

### BITS, INSERT . . . 453

**BLACK MAX® ADHESIVE . . . 371**

**BLADES**

Band Saw . . . 350  
Hack Saw . . . 347  
Jig/Sabre . . . 349  
Reciprocating Saw . . . 348  
Utility Knife . . . 460

**BLASTER PENETRANT . . . 401**

**BLOW GUN ATTACHMENTS . . . 438**

**BLUE LABEL HAND CLEANER . . . 383**

**BOLT CUTTERS . . . 432**

**BOLT GAUGES . . . 448**

**BOLT SNAPS . . . 320**

**BOLTS**

Anchor . . . 42  
Battery . . . 192  
Blade . . . 29, 31, 32, 33  
Body . . . 37  
Bumper . . . 37  
Carriage . . . 30, 31  
Carriage, S/S . . . 111  
Concrete Anchor . . . 42  
Elevator . . . 29, 30, 31  
Eye . . . 39  
Flange (12 point) . . . 27  
Grade 5 Heat Treated . . . 9  
Lag . . . 36  
Plow . . . 29, 31, 32, 33  
Scraper . . . 29, 31, 32, 33  
Shaker Screen . . . 32, 33  
Shoulder . . . 26  
Spinlock . . . 37  
Starter, 12 point . . . 27  
Stripper . . . 26  
Toggle . . . 47  
U-Bolts . . . 36  
Washer Hd. . . . 37

**BONDHUS STYLE WRENCHES . . . 455**

**BOOSTER CABLES & CLAMPS . . . 197**

**BOW-TIE LOCKING COTTER . . . 137**

**BOXES**

Corrugated Shelf . . . 482  
Styrene Parts . . . 483

**BRACES, BROOM HANDLE . . . 369**

**BRAKE**

Cleaner . . . 379  
Fluid . . . 405  
Fluid Pump . . . 208

**BRAKE LINE RACKS . . . 243**

**BRAKE LINE TUBING . . . 217**

**BRAKE LINES . . . 218, 243**

**BRAZING ROD . . . 414**

**BREAKERS CIRCUIT . . . 201**

**BREAKERS, ROLLER CHAIN . . . 324**

**BROOM HANDLES . . . 369**

**BROOMS. SEE ALSO BRUSHES**

Corn . . . 368  
Floor . . . 368, 369  
Street . . . 369  
Upright . . . 368

**BRUSH-ON ELECTRICAL TAPE . . . 389**

**BRUSHES. SEE ALSO BROOMS**

Acid . . . 367  
Battery Terminal . . . 196  
Bench . . . 368  
Can, Wheel & Fender . . . 367  
Chip & Oil . . . 367  
Circular End . . . 366  
Cup . . . 364, 365  
Disposable Paint . . . 367  
End . . . 366  
Fender . . . 367  
Floor . . . 369  
Hollow Center End . . . 366  
Mighty-Mite® . . . 364  
Paint . . . 367  
Parts . . . 367  
Scratch . . . 368, 420  
Small Angle Grinder . . . 364  
Small Welder's . . . 368, 420  
Straight End . . . 366  
Truck Wash . . . 367  
Tube Fitting . . . 366  
Wire End . . . 366  
Wire Wheel . . . 363, 366

**BRUTE LUBE . . . 398**

**BUDD WHEEL STUDS & NUTS . . . 35**

**BULBS**

Flashlight . . . 185  
Headlamp . . . 199  
Miniature . . . 198  
Tuff-Skin Coated . . . 180

**BUMP CAPS . . . 424**

**BUNGEE STRAPS . . . 469**

**BURRING REAMERS . . . 444**

**BURS, CARBIDE . . . 337**

**BUSHINGS. SEE ALSO FITTINGS**

Machinery . . . 99

**C**

**C-CLAMPS**

Drop Forged . . . 419, 450  
Locking . . . 452

**C5-A® COPPER ANTI-SEIZE . . . 395**

**CABINETS, DRILL . . . 346**

**CABINETS, STORAGE . . . 480, 481**

**CABLE**

Aircraft . . . 312  
Battery . . . 195  
Booster . . . 197  
Cutter (Copper) . . . 195  
Ferrules . . . 313  
Splices . . . 191  
Starter . . . 195  
Stops . . . 313  
Swagers . . . 313  
Tie Mounts . . . 174  
Tie Tensioner . . . 174  
Ties . . . 174, 175  
Trailer . . . 171  
Welding . . . 195, 420

**CABLE TIES . . . 174, 175**

**CABLES, JUMPER . . . 197**

**CALIPERS . . . 447**

**CAN BRUSH . . . 367**

**CAN LINERS . . . 467**

**CANS, GAS . . . 439**

**CANS, OIL . . . 439, 440**

**CAP SCREWS**

Brass . . . 113  
Button Hd. Socket . . . 20  
Flat Socket Hd. . . 20  
Hex Head . . . 9  
Metric . . . 119, 121  
Socket Head . . .  
20, 21, 22, 23, 24, 25, 28  
Stainless Steel . . . 103

**CAPS. SEE ALSO FITTINGS**

Grease Fitting . . . 303

**CAPS, BUMP . . . 424**

**CAPS, VACUUM . . . 280**

**CAR REAMERS . . . 332**

**CAR WASH & WAX . . . 377**

**CARB & CHOKE CLEANER . . . 380**

**CARBIDE BURS . . . 337**

**CARPET & ROOM DEODORIZER . . . 405**

**CART, WIRE SPOOL . . . 170**

**CARTON SEALING TAPE . . . 462**

**CAULK, SILICONE . . . 393**

**CAULKING GUN . . . 393**

**CAULKING GUNS . . . 444**

**CENTER PUNCH . . . 450**

**CHAIN**

Alloy (System 8) . . . 309  
Coil (Long Link) . . . 309  
Drive . . . 322  
High Test (System 4) . . . 309  
Lock Link . . . 310  
Log . . . 309  
Loop (Single & Double) . . . 310  
Machine (Twist Link) . . . 309  
Proof Coil (System 3) . . . 309  
Roller . . . 322  
Sprocket . . . 322  
Swing . . . 310  
Twist Link . . . 309

**CHAIN ACCESSORIES**

Alloy Coupling Links . . . 321  
Binders . . . 311  
Breakers . . . 324  
Clevises . . . 319  
Cold Shuts . . . 317  
Connecting Links  
Roller . . . 323  
Welded . . . 317  
Double Clevis (Mid Link) . . . 321  
Hooks . . . 316  
Links . . . 317, 321  
Pullers . . . 324  
Quick Links . . . 317  
Repair Links  
Roller . . . 323  
Welded . . . 317  
Shackles . . . 321

Snaps . . . 320

Tee Handle Clevis Pins . . . 319

**CHAIN AND CABLE LUBE . . . 399**

**CHARGER CLIPS . . . 197**

**CHEMICALS . . . 371, 410**

**CHICAGO FITTINGS . . . 281**

**CHIPPING HAMMER, WELD . . . 420**

**CHISELS . . . 442**

**CHOKE CLEANER . . . 380**

**CHOP SAW WHEELS . . . 356**

**CHUCK KEY HOLDER . . . 338**

**CHUCK KEYS, DRILL . . . 338**

**CHUCKS**

Air . . . 206  
Air, Quick Disconnect . . . 261, 266  
Ball Foot . . . 206  
Dual-Foot . . . 206  
Tire . . . 206

**CIRCUIT BREAKERS . . . 201**

**CITRA CLEAN HAND CLEANER . . . 382**

**CITRA CRYSTALS CONCRETE CLEANER . . . 377**

**CITRUS**

All Purpose Cleaner . . . 378  
Concrete floor cleaner . . . 377  
Degreaser . . . 376  
Hand cleaners . . . 382

**CLAMPING STUDS . . . 260**

**CLAMPS**

Band . . . 209  
Booster . . . 197  
Cable . . . 312  
Double Bolt . . . 281  
Flexible Exhaust Pipe . . . 209  
Grounding . . . 420  
Hose . . . 219, 275  
Hose Ferrules . . . 279  
Muffler . . . 209  
Nylon Tubing . . . 176, 218  
Tubing . . . 176, 218  
Welding . . . 420  
Wire Rope . . . 312

**CLEAN-WELD WELDING ROD . . . 413**

**CLEANERS . . . 376, 385**

**CLEANING SOLVENT . . . 379**

**CLEAR STYRENE BOXES . . . 483**

**CLEVIS PINS . . . 141, 142**

Tee Handle . . . 319

**CLEVISSES . . . 319, 321**

**CLIPS**

Alligator . . . 197  
Cable . . . 312  
Charger . . . 197  
Closed . . . 176, 218  
Frame . . . 176  
Tester . . . 197  
Wire Loom . . . 176  
Wire Rope . . . 312

**CLOTH UTILITY ROLLS . . . 358**

**CLOTHING, DISPOSABLE . . . 428**

**COATINGS . . . 385, 390**

**COBRA PLIERS . . . 434**

**COCKS. SEE VALVES**

**COIL CHAIN . . . 309**

**COLD SHUTS . . . 317**

**COLD ZINC GALVANIZE . . . 386**

**COLLARS, SHAFT . . . 146**

**COMBINATION NIPPLES . . . 282**  
**COMPACT FLUORESCENT LIGHTS . . . 178**

**CONCRETE CLEANER . . . 377**

**CONES FOR AXLE STUDS . . . 204**

**CONNECTING LINKS**

Alloy Chain . . . 321  
Proof Coil Chain . . . 317  
Roller Chain . . . 323

**CONNECTORS**

Electrical. See Terminals  
Fork Lift Battery . . . 193  
Pigtail . . . 203  
Wire Cord . . . 180

**CONTACT CLEANER . . . 380**

**CONVERSION KITS, NUTSERT . . . 58**

**COOLANT, METALWORKING . . . 398**

**COPPER ANTI-SEIZE . . . 395**

**CORD CONNECTORS . . . 180**

**CORD STOCK (O-RING) . . . 151**

**CORDS**

Drop . . . 179  
Extension . . . 180  
Power Reel . . . 180

**CORK GASKET MATERIAL . . . 466**

**CORN BROOMS . . . 368**

**COTTER PINS . . . 135**

**COTTER PINS, LOCKING . . . 137**

**COTTERS, HAIRPIN . . . 136**

**COUNTERSINKS . . . 329**

**COUPLER ADAPTER . . . 304**

**COUPLER MANIFOLD . . . 274**

**COUPLERS**

1/4 Turn Air (Chicago) . . . 281  
2-Lug . . . 281  
3000 Series . . . 270  
60 Series . . . 267  
6100 Series . . . 271  
6600 Series . . . 269  
Air Brake Hose . . . 260  
Aro Series . . . 264  
Button Head . . . 304  
Chicago . . . 281  
Connect Under Pressure . . . 271  
Garden Hose . . . 279  
Grease Fitting . . . 305  
Grease Gun . . . 305  
Hydraulic . . . 267, 271  
Industrial Series . . . 261, 263  
Lincoln Series . . . 264  
Pioneer Series . . . 268  
Push To Connect . . . 266  
Quick Disconnect . . . 261, 271  
Straight Thru Series . . . 266  
Thread-To-Connect . . . 271  
Threaded Rod . . . 62  
Tru-Flate Series . . . 265  
Welding Hose Disconnects . . . 415

**COUPLINGS. SEE FITTINGS**

**COUPLINGS, HOSE . . . 276, 294**

**COVERALLS, DISPOSABLE . . . 428**

**COVERS, CLEAR PLASTIC . . . 467**

**CRACK SEALER (FOAM) . . . 394**

**CRESCENT TOOLZALL PRO® . . . 436**

**CRIMPACE . . . 194**

**CRIMPER**

Air Hose . . . 279  
Battery Terminal . . . 195  
Wire . . . 181, 435  
Wire Rope . . . 313

**CROCUS CLOTH . . . 358**

**CUPRAN® SPECIAL . . . 381**

**CUPSTONES . . . 354**

**CUT-OFF WHEELS**

Adapters . . . 355, 366  
Chop Saws . . . 356  
Circular Saws . . . 355  
Concrete . . . 356  
Die Grinders . . . 355  
Portable Saws . . . 356

**CUTTERS**

Aviation Snips . . . 432  
Bolt . . . 432  
Copper Cable . . . 195  
Hose . . . 449  
Plastic Tubing . . . 449  
Replacement Wheels . . . 449  
Tubing, Copper . . . 449  
Wire Rope . . . 432

**CUTTING FLUID . . . 345, 397, 398**

**CUTTING TIP REFACING TOOL . . . 419**

**CUTTING TIPS . . . 416**

**CYANOACRYLATES . . . 371**

**D**

**DARK CUTTING OIL . . . 397**

**DAYCO CRIMP FITTINGS . . . 287, 289**

**DAYCO HYDRAULIC HOSE . . . 213, 215**

**DE-ICER**

Lock . . . 406  
Windshield . . . 406

**DECAL REMOVER . . . 394**

**DECIMAL CHART. SEE INSIDE BACK COVER**

**DEGREASER**

Engine . . . 378  
Solvent . . . 379

**DEODORIZER, CARPET & ROOM . . . 405**

**DIAPHRAGMS, AIR BRAKE . . . 260**

**DIE GRINDER WHEELS . . . 355**

**DIE STOCKS . . . 343**

**DIES . . . 343**

**DIGITAL MULTIMETER . . . 177**

**DISC HOLDER**

Back Up Pads . . . 360  
Flex-Finish . . . 362

**DISINFECTANT CLEANER . . . 378**

## DISPENSERS

- Drill Bit . . . 346
- Stockhausen . . . 381
- Wire Marker . . . 175, 466

## DISPENSERS, HAND CLEANER . . . 383

## DISPOSABLE COVERALLS . . . 428

## DIVIDERS

- Cabinet . . . 480

## D'LIMONENE PRODUCTS. SEE CITRUS CLEANERS

## DOUBLE CLEVIS LINKS . . . 321

## DOUBLE LOOP CHAIN . . . 310

## DOWEL PINS . . . 140

## DRAIN COCKS, BRASS . . . 249

## DRAIN PANS, OIL . . . 440

## DRAWERS, PARTS . . . 479

## DRESSER, GRINDING WHEEL . . . 358

## DRI-RITE (OIL DRY) . . . 384

## DRIFT PINS . . . 336

## DRILL

- Adapters . . . 336
- Chuck Keys . . . 338
- Dispensers . . . 346
- Drift Pins . . . 336
- Grinding Attachment . . . 346
- Index Cases . . . 346
- Key Holder . . . 338
- Rod . . . 63
- Saw (Combination) . . . 338
- Sharpeners . . . 346
- Tip Kit, Welding . . . 419

## DRILL DOCTOR® SHARPENER . . . 346

## DRILL SAW . . . 338

## DRILL SHARPENER . . . 346

## DRILL TAP . . . 338

## DRILL-OUT POWER EXTRACTORS . . . 335

## DRILLS

- A Taper Chuck & Adapters . . . 336
- Aircraft . . . 325
- Aircraft Extension . . . 330
- Brute . . . 326, 332
- Carbide Tipped . . . 335, 336
- Cobalt . . . 327
- Comb. Drill/Tap . . . 338
- Concrete . . . 335, 336
- Concrete Screw . . . 43, 335
- Double End . . . 333
- Extension . . . 330
- Extra Long . . . 330
- Hole Saw Pilot . . . 352
- Jobber . . . 325, 329
- Left Hand . . . 333
- Letter Gauge . . . 328
- Masonry Hammer . . . 335, 336
  - Concrete Screws . . . 43, 335
- Mechanics Length . . . 334
- Multi-Step . . . 327
- Number . . . 328, 329
- Reduced Shank . . . 330, 332
- Screw Machine . . . 333
- Sheeters . . . 333
- Short . . . 333
- Silver & Deming . . . 331, 332
- Standard Aircraft . . . 325
- Step . . . 327
- Stubby . . . 333
- Tap . . . 338
- Taper Chuck & Adapters . . . 336
- Taper Length . . . 330
- Unibit style . . . 327
- Wire Gauge . . . 328, 329

## DRIVE CHAIN . . . 322

## DRIVE FLANGE WEDGES . . . 35

## DRIVE SCREWS (RIVETS) . . . 69

## DRIVER'S GLOVES . . . 430

## DROP CLOTHS (PLASTIC) . . . 467

## DROP CORDS . . . 178, 179

## DRUM

- Faucets . . . 409
- ## DRY GRAPHITE LUBE . . . 398
- ## DRY MOLY LUBE . . . 398
- ## DUALCIDE INSECT SPRAY . . . 407
- ## DUCT TAPE . . . 462
- ## DUST MASKS . . . 425

## E

## E-Z OUTS . . . 334

## EAR PLUGS . . . 422

## EDGE CREME CUTTING LUBE . . . 397

## EDGE LUBE . . . 397

## ELBOWS. SEE FITTINGS

## ELECTRIC MOTOR CLEANER . . . 379

## ELECTRICAL

- AC Sensor . . . 177
- Alligator Clips . . . 197
- Auto Fuses . . . 200
- Auto Light Bulbs . . . 198, 199
- Battery Terminals . . . 187, 189, 190
- Booster Cables . . . 197
- Contact Cleaner . . . 380
- Cord Connectors . . . 180
- Drop Cords . . . 178, 179
- Extension Cords . . . 180
- Heat Guns . . . 183
- Mastic . . . 173, 464
- Plugs . . . 180
- Protective Tubing . . . 182
- Sealing Compound . . . 173, 464
- Solder . . . 184, 418
- Tape . . . 172, 173, 463, 464
- Terminals. See Terminals
- Tubing, Heat Shrink . . . 182
- Wiring Tools . . . 181, 435

## ELECTRICAL TAPE, BRUSH-ON . . . 389

## ELECTRODE HOLDERS . . . 420

## ELECTRODES . . . 412, 413

## ELEKTRALINK. SEE TERMINALS

## EMERY CLOTH . . . 358

## ENAMEL SPRAY PAINT . . . 387

## ENGINE DEGREASER . . . 378

## ENGINE STARTING FLUID . . . 405

## EPOXY . . . 372

## EQTM WELDING HELMETS . . . 421

## EQUIPMENT CLEANER . . . 377

## ESTESOL® HAND SOAP . . . 381

## ETHER (STARTING FLUID) . . . 405

## EXHAUST CLAMPS . . . 209

## EXTENSION CORD CONNECTORS . . . 180

## EXTENSION CORDS . . . 180

## EXTENSIONS, HOLE SAW . . . 352

## EXTINGUISHERS, FIRE . . . 426

## EXTRACTORS

- Screw . . . 334, 335

## F

## FACE SHIELDS/HEADGEAR . . . 424

## FAST ORANGE . . . 383

## FAUCETS, DRUM . . . 409

## FERRULES

- Air Brake Hose . . . 259
- Air Hose . . . 279
- Cable . . . 313
- Tubing
  - Copper . . . 225
  - Copper A/B . . . 231
  - Nylon A/B . . . 233, 234
  - Polyethylene . . . 238

## FIBER GASKET MATERIAL . . . 466

## FILES

- Metalworking . . . 443, 444
- Rotary . . . 337
- Thread Restoring . . . 346

## FILTER NIPPLES . . . 306

## FILTER WRENCH . . . 208

## FILTERS

- Air Line . . . 272
- Welding Lens . . . 422

## FIRE EXTINGUISHERS . . . 426

## FIRST AID KITS . . . 427

## FITTINGS

- Adapters . . . 294, 295
- Air Brake
  - Bulkhead . . . 260
  - Copper Tube . . . 231
  - Hose, SAE 100R5 . . . 284
  - Hose, Type B . . . 259
  - Nylon (NTA) . . . 233
  - Push-In (DOT) . . . 239, 240
- Air Hose
  - 1/4 Turn/Chicago . . . 281
  - 2-Lug . . . 281
  - Couplers . . . 261, 266
  - Ferrules . . . 279
  - Jack Hammer . . . 281
  - Push-On . . . 282, 283
  - Quick Disconnect . . . 261, 266
  - Reusable . . . 277
  - Swivels . . . 274
- Air Manifold . . . 274
- Barbed
  - Brass . . . 276

## Combination . . . 282

## Fuel & Heater . . . 277

## Garden Hose . . . 278

## King . . . 282

## Multi . . . 276

## Plastic . . . 280

## Push-On . . . 282, 283

## Steel . . . 282

## Vacuum . . . 280

## Welding . . . 275

## Wiper . . . 280

## Brake Line . . . 229

## Compression

## Copper (Std.) . . . 225

## Copper A/B . . . 231

## Nylon A/B (NTA) . . . 231

## Plastic Tube . . . 238

## Poly-Tite . . . 238

## Couplers . . . 261, 266, 271

## Crimp

## Dayco . . . 287

## Hose Ferrules . . . 279

## Parker . . . 290

## Double Compression, Brass . . . 228

## Flare

## Brass, SAE 45° . . . 235

## Steel, JIC 37° . . . 294, 295, 299

## Garden Hose . . . 278, 279

## Grease . . . 303

## Heater Hose . . . 277

## Hydraulic

## Adapters . . . 294, 295

## Coupler Dust Caps . . . 267, 271

## Coupler Mounting Flange . . . 271

## Couplers . . . 267, 271

## Crimp . . . 287, 294

## Crimp (Dayco) . . . 287, 289

## Crimp (Parker) . . . 290, 294

## Reusable . . . 284, 286

## Inverted Flare, Brass . . . 229

## Lubrication . . . 303

## O-Ring Adapters . . . 299, 301

## Pipe

## Brass . . . 244, 248

## Iron . . . 252, 253, 257

## Malleable Iron . . . 252, 253, 257

## Steel, Hi Pressure . . . 300

## Steel, Low Pressure . . . 252, 253, 257

## Swivel . . . 300

## Push-In . . . 239, 240

## Push-On . . . 282, 283

## Quarter Turn Air Couplings . . . 281

## Quick Disconnect . . . 261, 271

## Reusable

## Air Brake . . . 284

## Air Hose . . . 277

## Hydraulic, SAE 100R2 . . . 286

## Hydraulic, SAE 100R5 . . . 284

## Steel Barbed Type . . . 282

## Vacuum & Windshield Washer . . . 280

## Welding . . . 275

## FIXMASTERTM PIPE REPAIR KIT . . . 404

## FIXTURE SETTING COMPOUND . . . 394

## FLAME RETARDANT WELDER'S COAT . . . 430

## FLAP DISCS . . . 361

## FLAP WHEELS . . . 360

## FLARING CUPSTONES . . . 354

## FLARING TOOLS . . . 449

## FLASHBACK ARRESTORS . . . 415

## FLASHERS . . . 202

## FLASHLIGHT

## Aluminum . . . 185

## Batteries . . . 186

## Bulbs . . . 184

## Hazardous Location . . . 184, 426

## Industrial . . . 185

## Lantern . . . 184

## with Continuity Tester . . . 185

## FLAT WASHERS. SEE WASHERS

## FLEX GRINDING WHEELS . . . 354

## FLEX WHEEL . . . 354

## FLEX-SEAL EXHAUST CLAMPS . . . 209

## FLEXFINISH® DISCS . . . 362

## FLINTS, SPARK LIGHTER . . . 419

## FLOOR

## Broom Handles . . . 369

## Brooms . . . 368, 369

## Squeegees . . . 370

## Sweeping Compound . . . 384

## FLOW CHECK VALVES . . . 415

## FLOUORESCENT WORK LIGHTS . . . 178

## FLUX, SOLDERING . . . 184, 418

## FLYING INSECT KILLER . . . 407

## FOAM INSULATION . . . 394

## FOLDING RULE . . . 447

## FOOD GRADE SILICONE . . . 403

## FORK LIFT CONNECTORS . . . 193

## FOUNTAIN TUBE HANDLE . . . 367

## FRAME CLIPS . . . 176

## FRAMES, HACK SAW . . . 347

## FRL'S . . . 272

## FUEL CANS (GASOLINE) . . . 439

## FUEL CYLINDERS, PROPANE . . . 406, 417

## FUEL LINE ANTI-FREEZE . . . 405

## FUEL LINE HOSE . . . 216

## FUEL SYSTEM DRYER . . . 405

## FUNNELS . . . 440

## FUSEHOLDERS . . . 201

## FUSES, AUTOMOTIVE . . . 200

## FUSIONTM SOLDER TERMINALS . . . 187

## G

## GALVANIZING COMPOUND . . . 386

## GARBAGE BAGS . . . 467

## GARDEN HOSE . . . 278

## Fittings . . . 278, 279

## Nozzles . . . 278

## Quick Disconnect Couplers . . . 279

## Washers . . . 278

## GARDEN SPADES . . . 437

## GAS CANS . . . 439

## GAS LINE ANTI-FREEZE . . . 405

## GASKET

## Adhesives/Sealants . . . 391

## Makers . . . 391, 392, 393, 394

## Material . . . 466

## Remover . . . 394

## Sealant (Hi Tack) . . . 391

## Sealant, Aviation . . . 391

## Sealant No. 2 . . . 391

## GATE VALVES, BRONZE . . . 251

## GAUGES

## Battery Terminal . . . 448

## Bolt & Nut . . . 448

## Pressure . . . 273

## Screw Pitch . . . 448

## Tire . . . 207

## Wire . . . 448

## GEAR LUBE . . . 399

## GEAR PULLERS . . . 445, 446

## GLAD HANDS & SEALS . . . 260

## GLASS CLEANER . . . 378

## GLASS FUSES . . . 200

## GLASSES, SAFETY . . . 423

## GLOVE LINERS . . . 429

## GLOVES . . . 429, 430, 431

Masonry . . . 353  
Metal Cutting . . . 353  
Pipeline Notching . . . 353  
Quick-Lok . . . 359  
Resin Fiber . . . 360  
Trim-Kut . . . 359  
Wheel Dressers . . . 358  
Wheels. *See also* Grinding: Discs  
Adapters . . . 357  
Bench . . . 357  
Bushings . . . 357  
Chop Saw . . . 356  
Cut-Off . . . 355  
Flaring Cupstones . . . 354  
Silicon Carbide . . . 357  
**GRINDING DISCS. *SEE ALSO* GRINDING  
WHEELS**  
**GRIP PINS . . . 318**  
**GROUNDING**  
Clamp . . . 420  
Terminal (Star) . . . 162

## H

**HACK SAW**  
Blades . . . 347  
Frames . . . 347  
**HAIRPIN COTTERS . . . 136**  
**HALF LINKS . . . 323**  
**HALOGEN BULBS . . . 179**  
**HAMMER, CHIPPING . . . 420**  
**HAMMER HANDLES . . . 470**  
**HAND CLEANER . . . 381, 383**  
**HAND CLEANER DISPENSERS . . . 383**  
**HAND GUARD, CHISEL . . . 442**  
**HANDLES**  
Broom . . . 369  
Die . . . 343  
File . . . 444  
Fountain Tube . . . 367  
Hammer . . . 470  
Tap . . . 341  
Truck Wash Brush . . . 367  
**HANGER IRON . . . 209**  
**HANGERS, TAIL PIPE . . . 209**  
**HARD COAT FINISH . . . 389**  
**HARD HATS . . . 424**  
**HARD-SURFACING ROD . . . 413**  
**HARMONIC BAL. PULLER . . . 446**  
**HEADGEAR**  
Face Shield . . . 424  
**HEADLAMPS . . . 199**  
**HEARING PROTECTORS . . . 424**  
**HEAT GUNS . . . 183**  
**HEAT SHRINK TUBING . . . 182**  
**HEATER, ELECTRIC . . . 471**  
**HEATER HOSE . . . 216**  
**HEATER HOSE FITTINGS . . . 277**  
**HEATER VALVES . . . 252**  
**HELI COIL STYLE INSERTS . . . 52**  
**HELMET LINER . . . 427**  
**HELMETS**  
Protective . . . 424  
**HEX CRIMP . . . 195**  
**HEX KEY WRENCHES . . . 455, 458**  
**HI-TACK SEALANT . . . 391**  
**HIGH SOLIDS SPRAY PAINT . . . 387**  
**HIGH TEMP. GREASE . . . 308, 400**  
**HIGH TEMP. LUBRICANT . . . 395**  
**HIGH TEST CHAIN . . . 309**  
**HITCH PIN CLIPS . . . 136, 320**  
**HITCH PINS . . . 318, 319**  
**HOLD-DOWNS, BATTERY . . . 192**  
**HOLDER**  
Electrode . . . 420  
Grease Gun . . . 306  
Soapstone . . . 418  
**HOLE SAW SETS . . . 352**  
**HOLE SAWS & ARBORS . . . 351**  
**HOOK LATCH . . . 314**  
**HOOKS**  
Chain . . . 316  
Cup . . . 40  
Grab & Slip . . . 316  
Peg Board . . . 40  
"S" . . . 40  
Safety Swivel . . . 314  
Screw . . . 40  
**HOSE**  
1-Wire . . . 213, 284, 287  
2-Wire . . . 213, 286  
Acetylene . . . 275

Aeroquip style . . . 284  
**Air**  
Coiled . . . 212  
Contractor Grade . . . 212  
Jack Hammer . . . 212  
Multi-Purpose Neoprene . . . 212  
Push On . . . 212  
**Air Brake, SAE 100R5 . . . 284**  
**Air Brake, Type B . . . 215**  
Assembly, Air Brake . . . 205, 215  
Bend Protectors . . . 211  
Caddy, Air . . . 439  
Cloth Covered . . . 284  
Coiled . . . 212  
Contractors . . . 278  
Cutters . . . 217, 449  
Fuel Line . . . 216  
Garden . . . 278  
Gasoline . . . 216  
Grease Gun . . . 306  
Heater . . . 216  
High Pressure . . . 214, 290  
High Pressure, SAE 100R2 . . . 213, 286  
Hydraulic  
SAE 100R2AT . . .  
213, 214, 286, 290  
SAE 100R5 . . . 284  
Leader . . . 211  
Lock-On . . . 212  
Low Pressure  
Air . . . 211  
Air (1") . . . 213  
Push On . . . 212  
SAE 100R4 . . . 213  
SAE 30R2 . . . 213  
Shop . . . 211  
Medium Pressure  
SAE 100R1 . . . 213, 287  
SAE 100R5 . . . 284  
Nylon Coil . . . 212  
Poly-Air . . . 211  
Polyurethane Self-Store . . . 212  
Pressure Washer . . . 214  
Push-On . . . 212  
Return Line . . . 213  
SAE 100R1 . . . 213, 287  
SAE 100R2 . . . 213, 214, 286, 290  
SAE 100R5 . . . 284  
Silicone Heater . . . 216  
Snubber . . . 211  
Strain Relievers . . . 211  
Suction . . . 213  
Vacuum . . . 216  
Vapor Emission . . . 216  
Water . . . 278  
Welding . . . 275, 415  
Whips  
Air . . . 211  
Grease Gun . . . 306  
Windshield/Vacuum . . . 216  
Wiper . . . 216  
**HOSE BARBS. *SEE* FITTINGS**  
**HOSE CLAMP RACK . . . 219**  
**HOSE CLAMPS . . . 219, 275**  
**HOSE CRIMPER . . . 279**  
**HOSE ENDS . . . 276, 294**  
Dayco . . . 287  
Parker . . . 290  
**HYDRAULIC**  
Brake Lines . . . 218, 243  
Couplers . . . 267, 271  
Grease Fittings . . . 303  
Hose  
SAE 100R1 . . . 213, 287  
SAE 100R2 . . . 213, 214, 286, 290  
SAE 100R4 . . . 213  
SAE 100R5 . . . 284  
SAE 30R2 . . . 213  
Jack Oil . . . 399  
**HYDRAULIC/PNEUMATIC**  
Sealant . . . 374

## I

**ICE SCRAPER, SIDEWALK . . . 437**  
**IDC CONNECTORS. *SEE* TERMINALS**  
**IMPACT DRIVER . . . 434**  
**IMPACT GREASE . . . 308, 400**  
**INDEX CASES, DRILL . . . 346**  
**INFLATOR GAUGE . . . 207**  
**INSECT REPELLENT . . . 407**  
**INSERT BIT HOLDER . . . 72, 454**

**INSERT BITS . . . 453, 454**  
**INSERTS, THREAD REPAIR . . . 53, 57**  
**INSTALLATION KIT FOR CONCRETE  
SCREWS . . . 43**  
**INSTANT ADHESIVES . . . 371**  
**INSULATED CLOSED CLIPS . . . 176, 218**  
**INSULATION, AEROSOL FOAM . . . 394**  
**INSULATION DISPLACEMENT  
CONNECTORS. *SEE* TERMINALS**  
**INSULATORS, ALLIGATOR CLIP . . . 197**  
**INTERNAL THREAD CLEANER . . . 344**

## J

**J-B WELD EPOXY . . . 372**  
**JACK OIL . . . 399**  
**JACOBS KEYS . . . 338**  
**JAW SETS FOR RIVETERS . . . 48**  
**JIG SAW BLADES . . . 349**  
**JUMPER CABLES . . . 197**

## K

**KAP-TOGGLE ANCHORS . . . 47**  
**KEENSERT® THREAD INSERTS . . . 57**  
**KESTER SOLDERS . . . 184, 418**  
**KEY HOLDER . . . 338**  
**KEY STOCK . . . 147**  
**KEYS**  
Cotter . . . 135  
Drill Chuck . . . 338  
Half Moon . . . 146  
Woodruff . . . 146  
**KING NIPPLES . . . 282**  
**KITS . . . 475, 476**  
**KNIFE BLADES**  
Single Edge . . . 460  
Utility . . . 460  
**KNIVES**  
Putty . . . 461  
Utility . . . 459  
**KRESTO® HAND CLEANERS . . . 381**  
**KRIMP 'N SEAL TERMINALS. *SEE*  
TERMINALS**  
**KWIK WIPES® . . . 381**

## L

**L-WRENCHES . . . 455**  
**LAMPS**  
Flashlight . . . 185  
Halogen . . . 179  
Miniature . . . 198  
Power Reel . . . 179  
Retractable . . . 179  
Rough Service . . . 179, 180  
Sealed Beam . . . 199  
Trouble . . . 179  
**LAP LINKS . . . 317**  
**LASHING TIES . . . 174**  
**LATCH, HOOK . . . 314**  
**LATEX GLOVES . . . 431**  
**LEADER HOSE, AIR . . . 211**  
**LENS CLEANING STATIONS . . . 422**  
**LENSES, WELDING . . . 422**  
**LETTER STAMP SETS . . . 446**  
**LICENSE PLATE FASTENERS . . . 38**  
**LIGHTBULBS. *SEE* LIGHTS**  
**LIGHTER, SPARK . . . 419**  
**LIGHTS**  
Flashlight . . . 185  
Fluorescent Shop . . . 178  
Halogen . . . 179  
Miniature . . . 198  
Power Reel . . . 178, 179  
Retractable . . . 179  
Rough Service . . . 179, 180  
Safety Coated . . . 180  
Sealed Beam . . . 199  
Trouble . . . 178, 179  
**LIL' BRAZER WELDING ROD . . . 414**  
**LINERS**  
Trash Can . . . 467  
Winter Helmet . . . 427  
**LINERS, PAINT TRAY . . . 407, 465**  
**LINKS**  
Chain . . . 317, 321  
Connecting . . . 323  
Half . . . 323  
Master . . . 323  
Offset . . . 323

Roller . . . 323  
Roller Chain . . . 323  
**LIQUID ELECTRICAL TAPE . . . 389**  
**LIQUID STEAM CLEANING CONCENTRATOR . . . 376**  
**LOAD BINDERS . . . 311**  
**LOAD STRAPS, RATCHETING . . . 311**  
**LOCK LINK CHAIN . . . 310**  
**LOCK THAW DEICER . . . 406**  
**LOCK WASHERS. *SEE* WASHERS**  
**LOCKING COTTERS, BOW-TIE . . . 137**  
**LOCKING WRENCHES . . . 452**  
**LOCKS, MASTER . . . 471**  
**LOCTITE. *SEE* CHEMICALS**  
**LOCTITE® THREADLOCKERS . . . 373**  
**LOG CHAIN . . . 309**  
**LOOM . . . 175**  
**LOOM CLIPS . . . 176**  
**LOOP CHAIN . . . 310**  
**LPS® CUTTING LUBRICANTS . . . 397**  
**LUBE GUN . . . 307**  
**LUBRICANTS . . . 396**  
**LUBRICATION FITTINGS . . . 303**  
**LUBRICATOR OIL . . . 398**  
**LUBRICATORS, AIR LINE . . . 272**  
**LUBRIPATE GREASES . . . 308, 400**  
**LUGS**  
Power . . . 191  
Starter . . . 191  
**LUGS, STARTER . . . 189**  
**LYNCH PINS . . . 320**

## M

**MACHINE CHAIN . . . 309**  
**MACHINE-CAST WELDING ROD . . . 413**  
**MACHINISTS' COOLANT . . . 398**  
**MAGIC METAL EPOXY . . . 372**  
**MAGNETIC SCREWDRIVER SET . . .  
433, 453**  
**MANIFOLD, AIR COUPLER . . . 274**  
**MANIFOLD STUDS**  
Fractional . . . 34  
Metric . . . 125  
**MANILA ROPE . . . 314**  
**MARKERS, PAINT . . . 418**  
**MARKING TOOLS**  
Soapstone . . . 419  
Stamps . . . 446  
**MARKING WAND . . . 388**  
**MASKING TAPE . . . 461**  
**MASKS, DUST & PARTICLE . . . 425**  
**MASONRY**  
Grinding Discs . . . 353  
Hammer Drills . . . 335  
**MASTER LINKS . . . 323**  
**MASTER PAD LOCKS . . . 471**  
**MASTIC, ELECTRICAL . . . 173, 464**  
**MEASURES, LIQUID . . . 440**  
**MEASURING TOOLS**  
Battery Terminal . . . 448  
Bolt & Screw Gages . . . 448  
Folding Rule . . . 447  
O-Ring Sizing Cone . . . 150  
Pocket Slide Calipers . . . 447  
Screw Pitch Gages . . . 448  
Tape Measure . . . 447  
Vernier Calipers . . . 447  
**MECHANIC'S WIRE . . . 170**  
**MENDERS, HOSE. *SEE* FITTINGS**  
**METAL POLISH . . . 384**  
**METALWORKING COOLANT . . . 398**  
**METRIC**  
Bolt & Nut Gauge . . . 448  
Cap Screws  
Class 10.9 . . . 121  
Class 8.8 . . . 119  
Grease Fittings . . . 131  
Machine Screws . . . 129, 130  
Nuts . . . 127  
O-Ring Kit . . . 131, 151  
Pitch Gage . . . 132, 341  
Socket Screws . . . 122, 124  
Studs . . . 125  
Tap & Die Set . . . 342  
Tap-Drill Chart . . . 132  
Thread Inserts (Recoil) . . . 55  
Torque Guide . . . 133  
Washers . . . 128  
**MID-LINKS . . . 321**  
**MIG WELDING WIRE . . . 414**  
**MIGHTY-MITE BRUSHES . . . 364**

MINIATURE LIGHT BULBS, 12V ... 198  
MITTS, PAINTERS ... 407, 465  
MODULAR CONNECTORS ... 193  
MODULAR FRL'S ... 272  
MOISTURE DISPLACER ... 401, 402  
MOISTURE GUARD (MISTY) ... 401  
MOLDEX RESPIRATOR ... 425  
MOLY LUBE ... 398  
MOTOR ASSEMBLY GREASE ... 400  
MOTOR CLEANER, ELECTRIC ... 379  
MOUNTED FLAP WHEELS ... 360  
MOUNTED GRINDING POINTS ... 356  
MOUNTS, CABLE TIE ... 174  
MOUNTS, GREASE GUN ... 306  
MUFFLER CLAMPS ... 209  
MULTI-TOOL, TOOLZALL PRO ... 436  
MULTIPURPOSE CLEANER/DEGREASER ... 376

## N

NATURAL LATEX GLOVES ... 431  
NATURALLY CLEAN ... 382  
ND VIBRA-TITE ... 373  
NEEDLE VALVES ... 250  
NEVER-SEIZE ... 395  
NICKEL ANTI-SEIZE ... 395  
NIPPLES. *SEE* FITTINGS  
NO-CRIMP BUTT CONNECTORS ... 162  
NO. 2 GASKET SEALANT ... 391  
NOSEPIECES FOR RIVETERS ... 48  
NOZZLE SHIELD, SAFE-DE-SPAT ... 385  
NOZZLES, WATER ... 278  
NUMBER STAMPS ... 446  
NUTS

2-Way Lock ... 93  
Acme ... 63  
Acorn ... 93  
Air Cleaner Wing ... 96  
All Steel Lock ... 91  
Automotive 7/16" ... 90  
Battery ... 188, 192  
Brass Hex ... 113  
Cap ... 93  
Carburetor Wing ... 96  
Castle ... 94  
Esna ... 92  
Finished Hex ... 89  
Flange ... 93  
Frame ... 93  
Grade 2H ... 95  
Grade 8 & 9 ... 91  
Grade C (8) Lock ... 91  
Heavy ... 95  
High ... 95  
Jack ... 59  
Jam ... 90  
Kep ... 92  
Left Hand ... 95  
License Plate ... 38  
Locking ... 92, 93  
Machine Screw ... 93  
Metric ... 127  
Mirror ... 59  
Nutserts ... 58  
Nylon ... 38  
Nylon Insert, Reg ... 92  
Nylon Insert, Thin ... 92  
Oval Lock ... 91  
Pal Type ... 96  
Prong Type ... 93  
Push-On ... 96  
Reversible Lock ... 93  
Rivet ... 58, 59  
Rod Coupler ... 62  
Rubber Well ... 59  
Self Threading ... 96  
Serrated Lock ... 93  
Slotted ... 94  
Spinlock ... 93  
Square ... 90  
Stainless Steel Hex ... 108  
Tee ... 93  
Thick ... 91, 95  
Truck U-Bolt ... 95  
Well ... 59  
Wheel ... 35, 95  
Whiz-Lock ... 93  
Wing ... 96

NUTS OFF PENETRANT ... 402  
NUTSERTS ... 58  
NUTSETTER, MAGNETIC ... 454

## NYLON

Cable Ties ... 174, 175  
Closed Clips ... 176, 218  
Mounts ... 174  
Tubing Clamps ... 176, 218  
Adhesive Backed ... 176, 218

## O

### O-RING

Cord Stock ... 151  
Kits ... 151  
Pick ... 150  
O-RING SIZING CONE ... 150  
O-RINGS ... 148, 149, 150  
OFF@ INSECT REPELLENT ... 407  
OFFSET LINKS ... 323  
OIL

Air Tool ... 398  
Cans ... 439  
Cutting ... 397  
Hydraulic Jack ... 399  
Lubricating ... 396  
Lubricator ... 395  
OIL DRAIN PAN ... 440  
OIL DRY (DRI-RITE) ... 384  
OIL FILTER WRENCH ... 208  
OILERS (AIRLINE LUBRICATOR) ... 272  
OILERS (OIL CANS) ... 439  
ONE WAY SECURITY SCREWS ... 83  
OPEN GEAR LUBE ... 399  
ORANGE-BASED CHEMICALS. *SEE* CITRUS CLEANERS

## P

PACKING, SHEET ... 466  
PAD LOCKS ... 471  
PAINT ROLLER COVERS ... 407, 465  
PAINT & VARNISH REMOVER ... 380  
PAINT, GASKET & DECAL REMOVER ... 394  
PAINT MARKERS ... 389, 418  
PAINT MARKING WAND ... 388  
PAINT RESPIRATOR ... 425  
PAINT ROLLER FRAME ... 407, 465  
PAINT, SPRAY ... 387  
PAINT TRAY ... 407, 465  
PAINT TRAY LINERS ... 407, 465  
PAINTER'S MITTS ... 407, 465  
PANCAKES ... 205, 260  
PAPER SHOP TOWELS ... 468  
PARKER CRIMP FITTINGS ... 214, 290, 294  
PARKER HYDRAULIC HOSE ... 214  
PARR HAND CLEANER ... 383  
PARTS BINS ... 477, 482  
PARTS BRUSHES ... 367  
PARTS CLEANING SOLVENT ... 379  
PB B'LASTER PENETRANT ... 401  
PEG BOARD HOOKS ... 40  
PENETRATING LUBE W/PDTE ... 401  
PENETRATING OIL ... 402  
PERFORATED STRAPPING ... 209  
PICKS, O-RING ... 150  
PIGTAIL CONNECTORS ... 203  
Nylon Closed End ... 164  
Self-Stripping ... 166, 167  
PIN PUNCHES ... 441  
PINS  
Adjustable ... 142  
Bent Pull ... 142, 318  
Bow-Tie Locking Cotters ... 137  
Clevis ... 141, 142  
Clevis, T-Handle ... 319  
Coiled Spring ... 139  
Cotter ... 135  
Dowel ... 140  
Expansion ... 138  
Hairpin Cotter ... 136, 281  
Hitch ... 318, 319  
Lock ... 320  
Lynch ... 320  
Roll ... 138  
Safety ... 137  
Snap-Lock ... 319  
Spirol ... 139  
Spring ... 138  
Taper ... 142  
Tote (Safety) ... 319  
Universal Clevis ... 142

Wire Lock ... 320

## PIPE

Dope ... 375  
Joint Compound ... 375  
Tape ... 462  
Thread Compound ... 375  
Thread Cutting Oil ... 397  
Wrenches ... 432

### PIPE REPAIR KIT ... 404

## PLASTIC

Sheets (Clear) ... 467  
Tarps ... 469

## PLIERS

Cobra ... 434  
Retaining Ring ... 145  
Vise Grip ... 451  
PLUGS. *SEE* FITTINGS  
Extension Cord ... 180  
Trailer Connector ... 171

### POLY TARPS ... 469

POLYETHYLENE SPRAYERS ... 409  
POP-OFF VALVES, SAFETY ... 251, 274  
POROSITY SEALANT (LOCTITE) ... 374  
POSI-LOCK CONNECTORS ... 162  
POSITIVE SEAL BAND CLAMPS ... 209  
POWER LUGS ... 191  
POXY-PAK ... 372  
PREMOISTENED TOWELS ... 382  
PRESS FIT ASSIST ... 375  
PRESS FIT REPAIR ... 375  
PRESSURE

Gauges, Air ... 273  
Gauges, Tire ... 207  
Regulator ... 272  
Wash Detergent ... 376

### PRESSURE WASHER HOSE ... 214

### PRIMARY WIRE ... 169

### PRISM GEL ADHESIVE ... 371

### PROPANE FUEL/TORCHES ... 417

### PROTECTIVE WASHERS, BATTERY ... 385

### PRY BAR SET ... 434

## PULLERS

Gear ... 445, 446  
Harmonic Balancer ... 446  
Roller Chain ... 324

## PUMP

Barrel ... 408  
Brake Fluid ... 208  
Hand Cleaner ... 383  
Sprayers ... 409

### PUNCH, AUTOMATIC CENTER ... 450

### PUNCHES ... 441, 442

### PUSH-ON HOSE ... 212

### PUSH-ON RETAINERS ... 96

### PUTTY KNIVES ... 461

## Q

### QUARTER TURN AIR COUPLINGS ... 281

### QUARTZ HALOGEN BULBS ... 179

### QUICK DISCONNECT

Air Couplers ... 261, 266  
Garden Hose Couplers ... 279  
Hydraulic Couplers ... 267, 271  
Welding Hose Couplers ... 415

### QUICK LINKS ... 317

### QUICK-COTE+ TERMINAL PROTECTOR ... 385

### QUICK-CUTTER ... 195

### QUICK-LOK GRINDING DISCS ... 359

### QUICKHEAT GUN ... 183

### QUICKHOLD BATTERY HOLD-DOWNS ... 192

## R

### RACK

Hose Clamp ... 219

### RACKS

Slide ... 478  
Wire Spool ... 481

### RADIATOR DRAIN VALVES ... 249

### RATCHET STRAPS ... 311, 471

### RATCHET TIE DOWNS ... 311, 471

### RATCHETING SCREWDRIVERS ... 433

### RAZOR BLADES & SCRAPER ... 460

### READY ROD ... 60

### REAMER WRENCH, TAP AND ... 341

### REAMERS, BURRING ... 444

### REAMERS, CAR ... 332

### RECIPROCATING SAW BLADES ... 348

### RECOIL INSERTS ... 53, 55

### RECOIL TAPS ... 53, 55

### RECOVERY DRAIN PAN ... 440

### RED GREASE ... 399

### RED INSULATING VARNISH ... 386

### RED SILICONE ... 392

### REDUCERS. *SEE* FITTINGS

### REFACING TOOL, CUTTING TIP ... 419

## REPAIR LINKS

Roller Chain ... 323  
Welded Chain ... 317, 321

### REPELLENT, OFF@ INSECT ... 407

### REPLACEMENT PARTS FOR RIVETERS ... 48

### RESIN FIBER DISCS ... 360

### RESPIRATORS & DUST MASKS ... 425

## RETAINERS

Flat Push-On ... 96  
Hairpins ... 136

### RETAINING RING PLIERS ... 145

## RETAINING RINGS

E type ... 145  
External type ... 144  
Internal type ... 143

### RETRO-FIT TERMINALS ... 188

### RIM STUDS, TRUCK WHEEL ... 35

### RIVET NUTS ... 58, 59

### RIVET TOOLS ... 48

### RIVET WASHERS ... 50

## RIVETS

Blind ... 49, 50  
Drive (Type U) ... 69  
Nylon Drive ... 44  
Painted ... 50  
Pop ... 49  
Stainless Steel ... 50

### ROCK-CRUSHER WELDING ROD ... 413

## ROD

Brazing ... 414  
Drill ... 63  
Forming ... 64  
Storage Rack ... 64, 481  
Threaded ... 60, 63  
Welding ... 412, 413, 414

### ROD COUPLERS ... 62

### ROLL PIN PUNCHES ... 441

### ROLL PINS ... 138

### ROLLER CHAIN ... 322

Breakers ... 324

Links ... 323

Lubricant ... 399

Puller ... 324

### ROLLER COVERS, PAINT ... 407, 465

### ROLLER FRAME, PAINT ... 407, 465

### ROLOC TYPE DISCS ... 362

### ROOM DEODORIZER ... 405

## ROPE

Manila ... 314  
Polypropylene ... 314  
Tarp ... 469  
Wire ... 312

### ROPE RATCHETT ... 311

### ROTARY BARREL PUMP ... 408

### ROTARY FILES ... 337

### ROUGH SERVICE BULBS ... 179, 180

### RTV SILICONE ... 392, 393

## RUBBER

Air Brake Diaphragms ... 260  
Back Up Pads ... 360  
Coated Tube Clamps ... 176, 218  
Garden Hose ... 278  
Gasket Material, Red ... 466  
Glad Hand Seals ... 205, 260  
Gloves ... 376, 431  
O-Ring Stock ... 151  
O-Rings ... 148, 149, 150  
RTV Silicone ... 393  
Seals (Chicago Ftgs) ... 281  
Tape ... 172, 463  
Tarp Straps ... 469  
Tie-Down System ... 469  
Vacuum Caps ... 280  
Well Nuts ... 59

### RUBBERS, GLAD HAND ... 260

### RUBBERS, SQUEEGEE ... 370

### RULES ... 447

### RUST PREVENTATIVE ... 402

### RUST PREVENTATIVE FINISH ... 389

### RUST-BUSTER WELDING ROD ... 413

## S

### SABRE SAW BLADES . . . 349 SAFE-DE-SPAT . . . 385 SAFE-MATE BATTERY CONN. . . . 193 SAFETY

Blow Guns . . . 438  
Ear Plugs . . . 422  
Face Shields & Visors . . . 424  
First Aid Kits . . . 427  
Flashback Arrestors . . . 415  
Glasses . . . 423  
Goggles . . . 421  
Grip, Chisel . . . 442  
Hearing Protectors . . . 424  
Helmets (Bump Caps) . . . 424  
Hook Latch . . . 314  
Hooks . . . 314  
Light Bulbs, Coated . . . 180  
Pins . . . 137  
Pop-Off Valves . . . 251, 274  
Solvent Degreaser . . . 379

### SAFETY WALK TREADS, 3M . . . 465

### SANDING. SEE ABRASIVES

### SANDING SCREEN . . . 358

### SATCHEL CASES . . . 482

### SAW BLADES . . . 347, 350

### SAW, HOLE . . . 351

### SAW-DRILL . . . 338

### SAW-ZALL BLADES . . . 348

### SCOOPS (SHOVELS) . . . 437

### SCOTCH-BRITE PADS . . . 362

### SCOTCHLOK PERFORMANCE+ . . . 168

### SCOTCHLOK SPLICES . . . 166, 167

### SCOTCHLOK WIRE NUTS . . . 167

### SCRAPER

Ice (Sidewalk) . . . 437  
Putty Knife . . . 461  
Razor Blade . . . 459

### SCRATCH BRUSHES . . . 368, 420

### SCREEN-BAK . . . 358

### SCREW EXTRACTORS . . . 334

### SCREW GAUGES . . . 448

### SCREWDRIVER BITS . . . 453

### SCREWDRIVER SET, MAGNETIC . . .

433, 453

### SCREWDRIVER SET, SECURITY BIT . . .

433

### SCREWDRIVERS . . . 433

### SCREWS

12 Point Counterbore . . . 27  
Adjusting . . . 20  
Allen Head . . .  
20, 21, 22, 23, 24, 25, 28  
Automotive Trim . . . 79  
Brass . . . 113, 116  
Button Socket . . . 20  
Carriage . . . 30, 31  
Carriage, S/S . . . 111  
Chrome trim . . . 80, 81  
Concrete . . . 43  
Construction . . . 87  
Counterbore . . . 27  
Countersunk Hd. . . 20  
Deck . . . 74  
Drill . . . 86, 87  
Drive (Type U) . . . 69  
Drywall . . . 74  
Elevator . . . 29, 30, 31  
Finishing . . . 79  
Flat Socket Hd . . . 20  
Floor . . . 72  
Gr. 5 Hex Cap . . . 9  
Header Tek's . . . 72  
Headless Set . . . 20  
Hex Machine . . . 69  
Lag . . . 36  
License Plate . . . 38  
Machine . . . 65, 73  
Metric . . . 129, 130  
Metal Building . . . 87  
Metric . . . 119, 130  
Robertson Head . . . 82  
Self Drilling . . . 72, 86, 87  
Self Piercing . . . 85  
Self Tapping . . . 72, 85  
Sems . . . 37, 79  
Set . . . 20, 27  
Stainless Steel . . . 107  
Sheet Metal . . . 77, 87  
Shoulder . . . 26  
Socket Hd.

Alloy Steel . . .  
20, 21, 22, 23, 24, 25, 28  
Metric . . . 122, 125  
Stainless Steel . . . 105, 106, 107

Square Set . . . 20  
Stainless Steel . . . 103  
Stove Bolts . . . 65  
Tap-Con type . . . 43  
Tapping . . . 72, 77, 84  
Tek's® . . . 86, 87  
Thread Cutting . . . 72, 73  
Thumb . . . 71  
Trailer . . . 72  
Wafer Hd. . . 88  
Wall Liner . . . 88  
Wood

Brass . . . 116

Steel . . . 75

WoodGrip Drill . . . 87

Zip-In . . . 85

### SCRIBE . . . 450

### SCRIBER . . . 450

### SEALANT

Aviation Gasket . . . 391

Hi Tack Gasket . . . 391

Hydraulic/Pneumatic . . . 374

Pipe Joint Compound . . . 375

Thread . . . 375

### SEALANTS . . . 391, 394

### SEALED BEAM

Headlamps . . . 199

### SEALING COMPOUND . . . 173, 464

### SEALING TAPE . . . 462

### SEALS

Air Coupler (Chicago) . . . 281

Glad Hand . . . 205, 260

"O" Ring . . . 148, 150

### SECURES GEARS, PRO LOCK . . . 375

### SECURITY SCREWS . . . 83

### SEPARATORS (FILTERS) . . . 272

### SHACKLES . . . 319, 321

### SHAFT COLLARS . . . 146

### SHARPENER, DRILL . . . 346

### SHEET PACKING . . . 466

### SELF BOXES . . . 482

### SHIMS

Machinery Bushings . . . 99

Shim Stock . . . 467

### SHOP AIR HOSES . . . 211

### SHOP ROLLS . . . 358

### SHOP TOWELS, PAPER . . . 468

### SHOVELS . . . 437

### SHRINK TUBING, HEAT . . . 182

### SIDEWALK/ICE SCRAPER . . . 437

### SILICONE

Lubricant . . . 403

RTV . . . 392

### SINGLE LOOP CHAIN . . . 310

### SIPHON SPRAY GUN . . . 438

### SLEDGE HAMMER HANDLES . . . 470

### SLIDE RACKS . . . 478

### SLIP-SHOT II RED GREASE . . . 399

### SNAP LOCK PINS . . . 319

### SNAP RING PLIERS . . . 434

### SNAP RINGS. SEE RETAINING RINGS

### SNAPS, CHAIN . . . 320

### SOAPSTONE & HOLDERS . . . 418

### SOLDER

Battery Slugs . . . 194

### SOLDERING FLUX . . . 184, 418

### SOLVENT DEGREASERS . . . 379

### SOLVO-RUST PENETRANT . . . 402

### SOUND DEADENER . . . 386

### SPADES, GARDEN . . . 437

### SPARK LIGHTERS . . . 419

### SPARK PLUG

Inserts (Recoil) . . . 55

Thread Repair Kits (Recoil) . . . 54

### SPEAKER WIRE . . . 170

### SPECTACLES, VISITORS . . . 423

### SPIRAL LOOM . . . 175

### SPIROL PINS . . . 139

### SPLICERS, HOSE. SEE FITTINGS

### SPLIT BOLT CONNECTORS . . . 167

### SPLIT LOOM . . . 175

### SPLIT PINS . . . 138

### SPRAY ADHESIVE . . . 373

### SPRAY BOTTLES . . . 408

### SPRAY GUN, SIPHON . . . 438

### SPRAY PAINT . . . 387

### SPRAY PAINT, BIG RIG . . . 388

### SPRAY PAINT, HIGH SOLIDS . . . 387

### SPRAYERS, PUMP TYPE . . . 409

### SPRAYERS, TRIGGER . . . 408

### SPRING PINS . . . 138

### SPROCKET CHAIN . . . 322

### SPRUCE SPRAY PAINT . . . 387

### SQUARE KEY STOCK . . . 147

### SQUEEGEES . . . 370

### STAINLESS PLUMBER'S PUTTY . . . 394

### STAINLESS STEEL

Anchors . . . 41

Button Socket Cap Screws . . . 107

Cap Screws . . . 103

Cotter Pins . . . 112

Flat Washers . . . 109

Key Stock . . . 112

Lock Washers . . . 108

Machine Screws . . . 110

Nuts . . . 108

Polish . . . 384

Roller Chain . . . 322

Sheet Metal Screws . . . 111

Socket Cap Screws . . . 105, 106

Socket Set Screws . . . 107

Welding Rod . . . 414

### STAKING TOOL, TERMINAL . . . 181, 435

### STAMPS, LETTER/FIGURE . . . 446

### STARTER CABLE . . . 195

### STARTER LUGS . . . 191

### STARTING FLUID . . . 405

### STAY BATHROOM CLEANER . . . 378

### STEAM CLEANING CONCENTRATE . . .

376

### STI TAPS

Metric . . . 55

UNC/UNF . . . 53

### STOCK

Bar (Round) . . . 63

### STOCKHAUSEN HAND CLEANERS . . .

381

### STORAGE

Bins

Akro . . . 482

Cardboard . . . 482

Steel . . . 477

Boxes, Styrene . . . 483

Cabinets . . . 480

Miscellaneous . . . 481

Parts Drawers . . . 479, 482

Racks . . . 478, 481

### STRAIN RELIEVER, HOSE . . . 211

### STRAPPING

Perforated . . . 209

Tape (Filament) . . . 462

### STRAPS, RATCHET . . . 471

### STRAPS, TARP . . . 469

### STRAPS, TIE DOWN . . . 311, 471

### STREET BROOMS . . . 369

### STRING GLOVES . . . 429

### STRIPPERS

Wire . . . 181, 435

### STUD-TOP BATTERY NUTS . . . 188

### STUDS

Manifold

Fractional . . . 34

Metric . . . 125

Truck Wheel . . . 35

Wheel . . . 35

### SUCTION HOSE . . . 213

### SUPER BONDER® . . . 371

### SUPER IMPACT GREASE . . . 308, 400

### SUPER LUBE® W/TEFLON® . . . 396

### SUPER WEATHERSTRIP ADH. . . . 371

### SUPER-TEF W/TEFLON® . . . 402

### SUPPORT BELTS . . . 427

### SURFACE COND. DISCS . . . 362

### SWAGER, WIRE ROPE . . . 313

### SWEAT BANDS . . . 422

### SWEEPING COMPOUND . . . 384

### SWIVEL HOOKS . . . 314

### SWIVELS

Air Hose . . . 274

Chain . . . 314

Grease Gun . . . 305

## T

### T-HANDLE TANK WRENCH . . . 419

### TAIL PIPE HANGER . . . 209

### TAMPERPROOF SCREWS . . . 83

### TAP & DIE SETS . . . 342

### TAP & DRILL SIZES. SEE INSIDE BACK

### COVER

### TAP WRENCHES . . . 341

### TAP-DRILL SETS . . . 342

### TAPE

Carton Sealing . . . 462

Cloth Duct . . . 462

Electrical . . . 172, 173, 463, 464

Friction . . . 172, 463

Glass Cloth . . . 173, 464

Masking . . . 461

Measures . . . 447

Paper . . . 461

Plastic . . . 172, 173, 463, 464

Rubber Splicing . . . 172, 463

Safety Walk, 3M . . . 465

Sealing . . . 462

Self-vulcanizing . . . 172, 463

Strapping (Filament) . . . 462

Teflon Pipe . . . 462

Wire Marker . . . 175, 466

### TAPER PINS . . . 142

### TAPPING FLUID . . . 397

### TAPS

Brute . . . 340

Combination Drill/Tap . . . 338

Fractional . . . 339

Gun (Spiral Point) . . . 340

Heli Coil . . . 53, 55

High Speed . . . 339

Pipe . . . 340

Sets

3 Piece . . . 340

Spiral Point, Brute . . . 340

STI . . . 53, 55

Wrenches . . . 341

### TARPS & TARP STRAPS . . . 469

### TECHNICAL DATA

Cable Sizing Chart . . . 195

Cap Screw Specifications . . . 19

Decimal Equivalents. See Inside Back

Cover

Eye Bolt Load Limits . . . 39

Fitting Measurement . . . 221

Fitting Sizes . . . 222

Flat Washer Sizes . . . 100

Hex Key Size Chart . . . 22, 28

Hex Nut Sizes . . . 91

Hose Clamp Sizes . . . 220

Metric Tap Drill Chart . . . 132

Metric Torque Guide . . . 133

"O" Ring Gauge . . . 152

Pipe Sizes . . . 223, 224

Scotchlok Splices . . . 166, 167  
Scotchlok Wire Nuts . . . 167  
ScotchlokTM 2 . . . 168  
Self-Stripping Pigtail . . . 166, 167  
Snap Plug . . . 164  
Snap Spade . . . 160  
Spade . . . 160  
Splices . . . 161, 167  
Split Bolt Connectors . . . 167  
Star Ring (Grounding) . . . 162  
Starter Lug . . . 191  
Starter Lugs . . . 191  
T-Tap Quick Slide . . . 166  
Trailer Pin . . . 158  
Wire Nuts . . . 168

#### TESTER

AC Sensor . . . 177

**TESTER CLIPS . . . 197**

**THIMBLES, WIRE ROPE . . . 313**

#### THREAD

Cutting Oil . . . 397

Files . . . 346

Sealant, Vibra-Tite . . . 373

Sealant w/Teflon . . . 375

#### THREAD INSERTS

E-Z Lok . . . 56

Jack . . . 59

Keensert . . . 57

Nutsert . . . 58

Recoil . . . 52, 55

Well Nuts . . . 59

**THREAD PITCH GAGES . . . 448**

**THREAD TAPE . . . 462**

**THREADED ROD . . . 60, 63**

**THREADED ROD RACK . . . 64, 481**

**THREADLOCKER 242® . . . 374**

**THREADLOCKER 262® . . . 374**

**THREADLOCKERS . . . 373**

**TIE DOWNS . . . 311**

**TIE DOWNS, RATCHET . . . 471**

**TIE DOWNS STRAPS . . . 311**

**TIE-DOWNS, RATCHETING . . . 471**

**TIE-DOWNS STRAPS . . . 469**

#### TIES

Lashing . . . 174

Nylon Cable . . . 174, 175

**TINNERS FLUID . . . 184, 418**

**TIP CLEANERS, TORCH . . . 419**

**TIP DRILL KIT . . . 419**

**TIP REFACING TOOL . . . 419**

**TIPS, BLOW GUN . . . 438**

**TIPS, TORCH . . . 416**

#### TIRE

Chucks . . . 206

Gauge . . . 207

Inflator/Gauges . . . 207

Valve Cap . . . 206

Valve Cores . . . 206

Valve Extensions . . . 206

Valve, tubeless . . . 206

**TOGGLE BOLTS . . . 47**

**TOGGLE WINGS . . . 47**

**TOGGLERS . . . 45**

**TOILET/BATHROOM CLEANER . . . 378**

#### TOOLS

Aviation Snips . . . 432

Ball End L-Wrench Sets . . . 455

Battery Filler . . . 196

Battery Terminal Crimpers . . . 195

Bearing Separator . . . 446

Blow Gun Attachments . . . 438

Bolt Cutters . . . 432

C-Clamps . . . 419, 450

Cable Crimping . . . 195

Cable Cutters . . . 195

Cable Tie Tensioning . . . 174

Caulking Gun . . . 393

Caulking Guns . . . 444

Center Punches . . . 442

Chipping Hammers . . . 420

Chisels . . . 442

Cobra Pliers . . . 434

Concrete Screw Install Tool . . . 43

Crimping . . . 181, 195, 435

Cutting Tip Refacer . . . 419

Die Stocks . . . 343

Drill sharpener . . . 346

Drive Type Grease Fitting . . . 303

File Handles . . . 444

Files . . . 443

Flaring . . . 449

Fold-Up Hex Key Set . . . 458

Folding Rule . . . 447

Garden Spades . . . 437

Gear Pullers . . . 445

Grease Fitting Driver . . . 306

Grease Guns . . . 307

Hacksaw Frames . . . 347

Hammer Handles . . . 470

Heat Gun . . . 183

Hex Key Wrenches . . . 455, 458

Hollow Wall Anchor . . . 46, 59

Hose Crimper . . . 279

Ice Scraper . . . 437

Impact Driver . . . 434

Insert Bits . . . 453, 454

Locking Pliers . . . 451

Locking Wrenches . . . 452

Magnetic Insert Bit Holder . . . 72, 454

Magnetic Power Nutsetters . . . 454

Marking Stamps . . . 446

O-Ring Picks . . . 150

Oil Filter Wrench . . . 208

Oilers . . . 439

Pipe Wrenches . . . 432

Pitch Gages . . . 448

Pocket Slide Caliper . . . 447

Power Bits . . . 453

Propane Torches . . . 417

Pry Bar Set . . . 434

Pullers . . . 445

Punches . . . 441, 442

Retaining Ring Pliers . . . 145

Riveters . . . 48

Roll Pin Punches . . . 441

Roller Chain . . . 324

Scoops Shovels . . . 437

Screwdrivers . . . 433, 453

Scribe . . . 450

Security Bit Kit . . . 433

Shovels/Spades . . . 437

Siphon Spray Gun . . . 438

Soapstone Holders . . . 419

T-Handle Hex Wrench . . . 457, 458

Tank Wrench . . . 419

Tap Wrenches . . . 341

Tape Measures . . . 447

Terminal Staking . . . 181, 435

Tester, AC . . . 177

Thread Files . . . 346

Tip Drill Kit . . . 419

Tire Inflator . . . 206

ToolZall Pro® . . . 436

Torch Tip . . . 419

Transfer Punch Set . . . 442

Tubing Cutter . . . 449

Vernier Calipers . . . 447

Vise Grip . . . 451

Welding . . . 420

Wire Rope Swager . . . 313

Wire Stripper . . . 195

Wiring . . . 181, 435

**TOOTHBRUSH, WELDER'S . . . 368, 420**

#### TORCH

Cutting Tips . . . 416

Propane . . . 417

Tank Wrench . . . 419

Tip Cleaners . . . 419

Tip Refacing Tool . . . 419

**TORQMAX SCREWDRIVER . . . 433**

**TORQUE SPECS. . . . 18**

**TORX INSERT BITS . . . 453**

**TOWELS, HAND CLEANING . . . 381, 382**

**TOWELS, PAPER SHOP . . . 468**

**TRACTOR FUNNEL . . . 440**

#### TRAILER

Cable . . . 171

Connectors . . . 171, 203

Pigtails . . . 203

Pins . . . 158

**TRANSFER PUNCH SET . . . 442**

**TRASH CAN LINERS . . . 467**

**TRAY LINERS, PAINT . . . 407, 465**

**TRAY, PAINT . . . 407, 465**

**TREADS, SAFETY WALK . . . 465**

**TRIGGER SPRAYERS . . . 408**

**TRIGGER START TORCH . . . 417**

**TRIM-KUT® GRINDING DISCS . . . 359**

**TROUBLE LIGHTS . . . 178, 179**

#### TRUCK

Tire Gauge . . . 207

Wash Brushes . . . 367

**TRUCK WASH CONCENTRATE . . . 377**

**TUBE FITTING BRUSH . . . 366**

#### TUBING

Air Brake . . . 215

Brake Line . . . 217

Clamps . . . 176, 218

Clear Vinyl . . . 217

Copper . . . 217

Cutters

Metal . . . 449

Plastic . . . 217

Heat Shrinkable . . . 182

Hydraulic Brake . . . 218, 243

Nylon Air Brake . . . 215

Polyethylene . . . 217

Steel . . . 217, 218, 243

Vacuum . . . 216

Vinyl . . . 217

Windshield & Vacuum . . . 216

Wiper . . . 216

**TUFF-SKIN BULBS . . . 180**

**TUNGSTEN CARBIDE SCRIBER . . . 450**

**TURBO TOWELS . . . 382**

**TURN SIGNAL FLASHERS . . . 202**

**TURNBUCKLES . . . 315**

**TY-RAPS . . . 174, 175**

**TYVEK® STYLE COVERALLS . . . 428**

## U

**U-BOLTS . . . 36**

**ULTRA BLUE RTV, LOCTITE . . . 392**

**ULTRA COPPER RTV, LOCTITE . . . 392**

**UNDERCOATING, RUBBERIZED . . . 386**

**UNI-CAST WELDING ROD . . . 413**

**UNIONS. SEE FITTINGS**

**UPRIGHT BROOMS . . . 368**

**UTILITY BLADES . . . 460**

**UTILITY HEATER . . . 471**

**UTILITY KNIVES . . . 459**

**UTILITY ROLLS . . . 358**

## V

**VACUUM CAPS . . . 280**

**VALVE CAPS . . . 206**

**VALVE CORES . . . 206**

**VALVE-ACTION MARKERS . . . 389, 418**

**VALVE-ACTION PAINT MARKERS . . . 418**

#### VALVES

Air Brake . . . 249

Ball . . . 251

Barrel Faucet . . . 409

Drain . . . 249

Drum . . . 409

Gate . . . 251

Heater . . . 252

Needle . . . 250

Reverse Flow Check . . . 415

Safety Pop-Off . . . 251, 274

Tank . . . 206

Tire . . . 206

**VANDALISM MARK REMOVER . . . 380**

**VERNIER CALIPERS . . . 447**

**VIBRA-TITE . . . 373**

**VISE-GRIPS . . . 451**

**VISORS, FACESHIELD . . . 424**

**VITON O-RING KIT . . . 151**

## W

**WARNING FLASHERS . . . 202**

**WASHERS . . . 97, 102**

Alloy Lock . . . 101

AN . . . 109

Army-Navy . . . 109

Backup for Rivets . . . 50

Battery . . . 385

Brass . . . 114

Countersunk . . . 98, 101

External Lock . . . 101

Extra Thick Flat . . . 98

Fender . . . 98

Finishing . . . 98

Flat Machine Screw . . . 97

Flat USS/SAE . . . 97

Garden Hose . . . 278

Hi-Collar Lock . . . 102

Internal Lock . . . 101

Lock . . . 101, 102

Machine Screw . . . 97

Machinery Bushings . . . 99

Metric . . . 128

Military . . . 109

MS . . . 109

Oversize . . . 98

Plaster . . . 98

Shakeproof . . . 101

Socket Cap Screw . . . 102

Spacers . . . 99

Spring . . . 101

Stainless Steel . . . 108, 109

Star . . . 101

Thick Fender . . . 98

Thick Flat . . . 98

Tooth . . . 101

Trim . . . 98

Wrought . . . 97

**WASP & HORNET KILLER . . . 407**

**WATER NOZZLE . . . 278**

Spool Truck . . . 170  
Starter . . . 195  
Ties . . . 174, 175  
Trailer Cable . . . 171  
Welding Cable . . . 195  
Wheel Brushes . . . 363, 366  
Wrap . . . 175  
**WIRE BRUSHES . . . 363, 368, 420**  
**WOODRUFF KEYS . . . 146**  
**WORK GLOVES . . . 430**  
**WORK LIGHTS . . . 178**  
**WRENCHES**  
Bondhus Style . . . 455  
Filter . . . 208  
Hex Key . . . 455, 458  
Pipe . . . 432  
Tap . . . 341  
Vise-Grip . . . 451

## **Z**

**ZERKS, GREASE . . . 303**  
**ZINC GALVANIZING SPRAY . . . 386**  
**ZIRCONIA GRINDING WHEELS . . . 353**



# Hex Head Cap Screws

## GRADE 5 HEX CAP SCREWS

The industry standard for medium strength applications. Features sharp rolled class 2A threads, full washer face and chamfered ends.

Tensile strength: 120,000 psi. minimum  
Hardness: Rockwell C25-34  
Finish: Blue chromate dipped (to 1" dia., 6" lgth)

Material: Medium carbon C1038 steel  
Grade mark: 3 radial lines  
Meets or exceeds ASME/ANSI B18.2.1, ASTM A354, SAE J429



## GRADE 2 HEX TAP BOLTS (FULLY THREADED)

A threaded to the head fastener for use in pre-tapped holes. Use as leveling screws or as adjustment screws found on belt and chain tensioners. Features sharp rolled class 2A threads and chamfered ends.

Tensile strength: 74,000 psi. minimum  
Hardness: Rockwell B80-B100  
Finish: Blue chromate dipped

Material: AISI 1006 - 1025 steel  
Grade mark: none  
Meets or exceeds ANSI B18.2.1, ASTM A354, SAE J429



## GRADE 8 ALLOY HEX CAP SCREWS

Our most popular bolt is ideal for use where strength is a major concern. Stocked in Gold Dichromated finish and unplated (black finish) Sharp rolled class 2A threads, full washer face and chamfered ends.

Tensile strength: 150,000 psi. minimum  
Hardness: Rockwell C33-39  
Finish: Gold Dichromate dipped (to 1" dia., 6" lgth) or unplated (black finish)

Material: Medium carbon 4140 alloy steel  
Grade mark: 6 radial lines  
Meets or exceeds ASME/ANSI B18.2.1, ASTM A354, SAE J429



## GRADE 8 ALLOY HEX FLANGE BOLTS (FRAME BOLTS)

Originally used on truck frames and for automotive body applications. Features time-saving flange design which provides more bearing surface to minimize bolt-hole preparation. Use with corresponding flange lock nuts (frame nuts).

Tensile strength: 150,000 psi. minimum  
Hardness: Rockwell C33-39  
Finish: Unplated (black and oiled)

Material: Medium carbon 4140 alloy steel  
Grade mark: 6 radial lines  
Meets or exceeds SAE J429 and IFI-111



## GRADE L9 ALLOY HEX CAP SCREWS

Grade L9 cap screws feature 20% thicker heads for non-slip wrenching. The worlds strongest off-the-shelf fastener offers the highest minimum tensile strength and the highest resistance to cracking, wear and metal fatigue available when used with corresponding grade L9 components. Sharp rolled class 2A threads, full washer face and chamfered ends.

Tensile strength: 180,000 psi. minimum  
Hardness: Rockwell C38-42  
Finish: Gold Dichromate dipped

Material: Heat treated 4140 modified alloy steel.  
Grade mark: 9 radial lines  
Meets or exceeds ASTM A354 and SAE J429

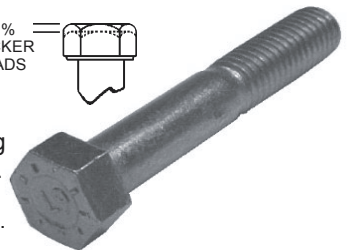
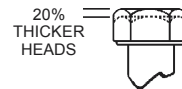

**Made in U.S.A.\***

*\*We reserve the right to substitute product made in Canada in times of shortage. All standards still apply. All fasteners on this page are head-marked for complete traceability. Certifications available on request.*



# Hex Head Cap Screws

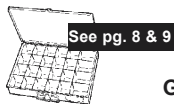

**GRADE 5 HEX  
CAP SCREWS**

**GRADE 2 HEX  
TAP BOLTS**

**GRADE 8 HEX  
CAP SCREWS**

**GRADE 8 HEX  
CAP SCREWS**

**GRADE L9 HEX  
CAP SCREWS**

LENGTH	BRIGHT ZINC†	BRIGHT ZINC	ZINC DICHROMATE		BLACK		ZINC DICHROMATE		Pkg Qty
	COARSE	COARSE	COARSE	FINE	COARSE	FINE	COARSE	FINE	

## 1/4" DIAMETER 1/4-20 COARSE (NC), 1/4-28 FINE (NF) WRENCH SIZE: 7/16"

1/2	NC100-1	-	NC100-2	NF100-2	NC100-2B	-	NC100-3	-	100
5/8	NC101-1	-	NC101-2	NF101-2	-	-	-	-	
3/4	NC102-1	-	NC102-2	NF102-2	NC102-2B	-	NC102-3	-	
7/8	NC103-1	-	NC103-2	NF103-2	-	-	-	-	
1"	NC104-1	-	NC104-2	NF104-2	NC104-2B	-	NC104-3	-	
1-1/4	NC105-1	9-500	NC105-2	NF105-2	NC105-2B	-	NC105-3	-	
1-1/2	NC106-1	9-501	NC106-2	NF106-2	NC106-2B	-	NC106-3	-	
1-3/4	NC107-1	-	NC107-2	NF107-2	NC107-2B	-	NC107-3	-	
2"	NC108-1	9-502	NC108-2	NF108-2	NC108-2B	-	NC108-3	-	
2-1/4	NC109-1	-	NC109-2	NF109-2	-	-	-	-	
2-1/2	NC110-1	9-503 <sub>(100)</sub>	NC110-2	NF110-2	NC110-2B	-	NC110-3 <sub>(100)</sub>	-	50
2-3/4	NC111-1	-	NC111-2	NF111-2	-	-	-	-	
3"	NC112-1	9-504 <sub>(100)</sub>	NC112-2	NF112-2	NC112-2B	-	NC112-3 <sub>(100)</sub>	-	
3-1/4	NC113-1	-	NC113-2	NF113-2	-	-	-	-	
3-1/2	NC114-1	9-505 <sub>(100)</sub>	NC114-2	NF114-2	NC114-2B	-	-	-	
3-3/4	NC115-1	-	NC115-2	NF115-2	-	-	-	-	
4"	NC116-1	9-506 <sub>(100)</sub>	NC116-2	NF116-2	NC116-2B	-	-	-	
4-1/2	NC118-1	-	NC118-2	NF118-2	-	-	-	-	
5"	NC120-1	-	NC120-2	NF120-2	-	-	-	-	25
5-1/2	NC121-1	-	NC121-2	NF121-2	-	-	-	-	
6"	NC122-1	-	NC122-2	NF122-2	-	-	-	-	
7"	NC124-1*	-	* Bolts over 6 inch in		NC124-2B	-	-	-	1
8"	NC126-1*	-	* Black finish only →		NC126-2B	-	-	-	

## 5/16" DIAMETER 5/16-18 COARSE (NC), 5/16-24 FINE (NF) WRENCH SIZE: 1/2"

1/2	NC200-1	-	NC200-2	NF200-2	NC200-2B	-	NC200-3	-	100
5/8	NC201-1	-	NC201-2	NF201-2	-	-	-	-	
3/4	NC202-1	-	NC202-2	NF202-2	NC202-2B	-	NC202-3	-	
7/8	NC203-1	-	NC203-2	NF203-2	-	-	-	-	
1"	NC204-1	-	NC204-2	NF204-2	NC204-2B	-	NC204-3	-	
1-1/4	NC205-1	9-507	NC205-2	NF205-2	NC205-2B	-	NC205-3	-	
1-1/2	NC206-1	9-508	NC206-2	NF206-2	NC206-2B	-	NC206-3	-	
1-3/4	NC207-1	-	NC207-2	NF207-2	NC207-2B	-	NC207-3	-	
2"	NC208-1	9-509	NC208-2	NF208-2	NC208-2B	-	NC208-3	-	
2-1/4	NC209-1	-	NC209-2	NF209-2	-	-	-	-	
2-1/2	NC210-1	9-510 <sub>(100)</sub>	NC210-2	NF210-2	NC210-2B	-	NC210-3 <sub>(100)</sub>	-	50
2-3/4	NC211-1	-	NC211-2	NF211-2	-	-	-	-	
3"	NC212-1	9-511 <sub>(100)</sub>	NC212-2	NF212-2	NC212-2B	-	NC212-3 <sub>(100)</sub>	-	
3-1/4	NC213-1	-	NC213-2	NF213-2	-	-	-	-	
3-1/2	NC214-1	9-512	NC214-2	NF214-2	NC214-2B	-	NC214-3	-	
3-3/4	NC215-1	-	NC215-2	NF215-2	-	-	-	-	
4"	NC216-1	9-513	NC216-2	NF216-2	NC216-2B	-	NC216-3	-	
4-1/2	NC218-1	-	NC218-2	NF218-2	-	-	-	-	
5"	NC220-1	-	NC220-2	NF220-2	-	-	-	-	25
5-1/2	NC221-1	-	NC221-2	NF221-2	-	-	-	-	
6"	NC222-1	-	NC222-2	NF222-2	-	-	-	-	
7"	NC224-1*	-	* Bolts over 6 inch in		NC224-2B	-	-	-	1
8"	NC226-1*	-	* Black finish only →		NC226-2B	-	-	-	

\*Sizes over 6" are unplated. †Zinc plated through 6" long. All lengths measured from under head.  
 Sizes not listed may be available as a special order (subject to minimum packaging).

# Hex Head Cap Screws

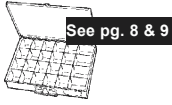

GR.5 HEX  
CAP SCREWS

GR.2 HEX  
TAP BOLTS

GRADE 8 HEX  
CAP SCREWS

GRADE 8 HEX  
CAP SCREWS

GRADE 8 HEX  
FLANGE SCREWS

GRADE L9 HEX  
CAP SCREWS

LENGTH	ZINC†	ZINC	ZINC DICHROMATE		BLACK		BLACK		ZINC DICHROMATE		Pkg Qty
	COARSE	COARSE	COARSE	FINE	COARSE	FINE	COARSE	FINE	COARSE	FINE	

## 3/8" DIAMETER 3/8-16 COARSE (NC), 3/8-24 FINE (NF) WRENCH SIZE: 9/16"

1/2	NC300-1	-	NC300-2	-	-	-	-	-	-	-	100
5/8	NC301-1	-	NC301-2	NF301-2	-	-	-	-	-	-	
3/4	NC302-1	-	NC302-2	NF302-2	NC302-2B	-	-	-	NC302-3	-	
7/8	NC303-1	-	NC303-2	NF303-2	-	-	-	-	-	-	
1"	NC304-1	-	NC304-2	NF304-2	NC304-2B	-	9-200	-	NC304-3	-	
1-1/4	NC305-1	-	NC305-2	NF305-2	NC305-2B	-	9-201	-	NC305-3	-	
1-1/2	NC306-1	9-514(50)	NC306-2	NF306-2	NC306-2B	-	9-202	-	NC306-3	-	
1-3/4	NC307-1	-	NC307-2	NF307-2	NC307-2B	-	9-203	-	NC307-3	-	
2"	NC308-1	9-515(50)	NC308-2	NF308-2	NC308-2B	-	-	-	NC308-3 <sub>(50)</sub>	-	
2-1/4	NC309-1	-	NC309-2	NF309-2	-	-	-	-	-	-	
2-1/2	NC310-1	9-516	NC310-2	NF310-2	NC310-2B	-	-	-	NC310-3	-	50
2-3/4	NC311-1	-	NC311-2	NF311-2	-	-	-	-	-	-	
3"	NC312-1	9-517	NC312-2	NF312-2	NC312-2B	-	-	-	NC312-3	-	
3-1/4	NC313-1	-	NC313-2	NF313-2	-	-	-	-	-	-	
3-1/2	NC314-1	9-518	NC314-2	NF314-2	NC314-2B	-	-	-	NC314-3 <sub>(25)</sub>	-	
3-3/4	NC315-1	-	NC315-2	NF315-2	-	-	-	-	-	-	
4"	NC316-1	9-519	NC316-2	NF316-2	NC316-2B	-	-	-	NC316-3 <sub>(25)</sub>	-	
4-1/2	NC318-1	-	NC318-2	NF318-2	-	-	-	-	-	-	
5"	NC320-1	9-520(50)	NC320-2	NF320-2	-	-	-	-	-	-	25
5-1/2	NC321-1	-	NC321-2	NF321-2	-	-	-	-	-	-	
6"	NC322-1	-	NC322-2	NF322-2	-	-	-	-	-	-	
6-1/2	NC323-1*	-	-	-	NC323-2B	-	-	-	-	-	1
7"	NC324-1*	-	<i>Bolts over 6 inch in Black finish only →</i>		NC324-2B	-	-	-	-	-	
8"	NC326-1*	-	<i>Bolts over 6 inch in Black finish only →</i>		NC326-2B	-	-	-	-	-	

## 7/16" DIAMETER 7/16-14 COARSE (NC), 7/16-20 FINE (NF) WRENCH SIZE: 5/8"

3/4	NC402-1	-	NC402-2	NF402-2	NC402-2B	-	-	-	-	-	100
1"	NC404-1	-	NC404-2	NF404-2	NC404-2B	-	-	-	-	-	
1-1/4	NC405-1	-	NC405-2	NF405-2	NC405-2B	-	-	-	NC405-3 <sub>(50)</sub>	-	
1-1/2	NC406-1	-	NC406-2	NF406-2	NC406-2B	-	-	-	NC406-3 <sub>(50)</sub>	-	
1-3/4	NC407-1	-	NC407-2	NF407-2	NC407-2B	-	-	-	-	-	
2"	NC408-1	-	NC408-2	NF408-2	NC408-2B	-	-	-	NC408-3 <sub>(50)</sub>	-	
2-1/4	NC409-1	-	NC409-2	NF409-2	-	-	-	-	-	-	50
2-1/2	NC410-1	-	NC410-2	NF410-2	NC410-2B	-	-	-	NC410-3	-	
2-3/4	NC411-1	-	NC411-2	NF411-2	-	-	-	-	-	-	
3"	NC412-1	-	NC412-2	NF412-2	NC412-2B	-	-	-	NC-412-3	-	
3-1/4	NC413-1	-	NC413-2	NF413-2	-	-	-	-	-	-	
3-1/2	NC414-1	-	NC414-2	NF414-2	NC414-2B	-	-	-	-	-	25
3-3/4	NC415-1	-	NC415-2	NF415-2	-	-	-	-	-	-	
4"	NC416-1	-	NC416-2	NF416-2	NC416-2B	-	-	-	-	-	
4-1/2	NC418-1	-	NC418-2	NF418-2	-	-	-	-	-	-	
5"	NC420-1	-	NC420-2	NF420-2	-	-	-	-	-	-	
5-1/2	NC421-1	-	NC421-2	NF421-2	-	-	-	-	-	-	
6"	NC422-1	-	NC422-2	NF422-2	-	-	-	-	-	-	
7"	NC424-1	-	<i>Bolts over 6 inch in Black finish only →</i>		NC424-2B	-	-	-	-	-	1
8"	NC426-1	-	<i>Bolts over 6 inch in Black finish only →</i>		NC426-2B	-	-	-	-	-	

\*Sizes over 6" are unplated. †Zinc plated through 6" long. All lengths measured from under head.

Sizes not listed may be available as a special order (subject to minimum packaging).



# Hex Head Cap Screws



**GRADE 5  
CAP SCREWS TAP BOLTS**

**GRADE 2  
CAP SCREWS**

**GRADE 8 HEX  
CAP SCREWS**

**GRADE 8 HEX  
FLANGE SCREWS**

**GRADE L9 HEX  
CAP SCREWS**

LENGTH	ZINC†	ZINC	ZINC DICHROMATE		BLACK		BLACK		ZINC DICHROMATE		Pkg Qty
	COARSE	COARSE	COARSE	FINE	COARSE	FINE	COARSE	FINE	COARSE	FINE	

## 1/2" DIAMETER 1/2-13 COARSE (NC), 1/2-20 FINE (NF) WRENCH SIZE: 3/4"

3/4	NC502-1	-	NC502-2	NF502-2	-	-	-	-	-	-	50
1"	NC504-1	-	NC504-2	NF504-2	NC504-2B	-	9-204 <sub>(25)</sub>	9-608 <sub>(25)</sub>	NC504-3	NF504-3	
1-1/4	NC505-1	-	NC505-2	NF505-2	NC505-2B	-	9-205 <sub>(25)</sub>	9-609 <sub>(25)</sub>	NC505-3	NF505-3	
1-1/2	NC506-1	9-521	NC506-2	NF506-2	NC506-2B	-	9-206 <sub>(25)</sub>	9-610 <sub>(25)</sub>	NC506-3	NF506-3	
1-3/4	NC507-1	-	NC507-2	NF507-2	NC507-2B	-	9-207 <sub>(25)</sub>	9-611 <sub>(25)</sub>	NC507-3	NF507-3	
2"	NC508-1	9-522	NC508-2	NF508-2	NC508-2B	-	9-208 <sub>(15)</sub>	9-612 <sub>(15)</sub>	NC508-3	NF508-3	
2-1/4	NC509-1	-	NC509-2	NF509-2	NC509-2B	-	9-209 <sub>(15)</sub>	-	-	-	
2-1/2	NC510-1	9-523(50)	NC510-2	NF510-2	NC510-2B	-	9-210 <sub>(15)</sub>	-	NC510-3 <sub>(50)</sub>	NF510-3 <sub>(50)</sub>	25
2-3/4	NC511-1	-	NC511-2	NF511-2	-	-	9-211 <sub>(15)</sub>	-	-	-	
3"	NC512-1	9-524(50)	NC512-2	NF512-2	NC512-2B	-	9-212 <sub>(15)</sub>	-	NC512-3 <sub>(50)</sub>	NF512-3 <sub>(50)</sub>	
3-1/4	NC513-1	-	NC513-2	NF513-2	-	-	9-213 <sub>(15)</sub>	-	-	-	
3-1/2	NC514-1	9-525(25)	NC514-2	NF514-2	NC514-2B	-	9-226 <sub>(15)</sub>	-	NC514-3	NF514-3	
3-3/4	NC515-1	-	NC515-2	NF515-2	-	-	-	-	-	-	
4"	NC516-1	9-526(25)	NC516-2	NF516-2	NC516-2B	-	-	-	NC516-3	NF516-3	
4-1/2	NC518-1	-	NC518-2	NF518-2	NC518-2B	-	-	-	NC518-3	-	
5"	NC520-1	9-527(25)	NC520-2	NF520-2	NC520-2B	-	-	-	NC520-3	-	
5-1/2	NC521-1	-	NC521-2	NF521-2	NC521-2B	-	-	-	-	-	
6"	NC522-1	-	NC522-2	NF522-2	NC522-2B	-	-	-	NC522-3	-	
6-1/2	NC523-1*	-	-	-	NC523-2B	-	-	-	-	-	1
7"	NC524-1*	-	-	-	NC524-2B	NF524-2B	-	-	-	-	
7 1/2"	NC525-1*	-	-	-	NC525-2B	-	-	-	-	-	
8"	NC526-1*	-	<i>Bolts over 6 inch in Black finish only →</i>		NC526-2B	NF526-2B	-	-	-	-	
9"	NC528-1*	-	-	-	NC528-2B	-	-	-	-	-	
10"	NC530-1*	-	-	-	NC530-2B	-	-	-	-	-	
12"	-	-	-	-	NC534-2B	-	-	-	-	-	

## 9/16" DIAMETER 9/16-12 COARSE (NC), 9/16-18 FINE (NF) WRENCH SIZE: 13/16"

1"	NC604-1	-	NC604-2	NF604-2	-	-	-	-	-	-	50
1-1/4	NC605-1	-	NC605-2	NF605-2	-	-	-	-	-	-	
1-1/2	NC606-1	-	NC606-2	NF606-2	-	-	-	-	-	-	25
1-3/4	NC607-1	-	NC607-2	NF607-2	-	-	-	-	-	-	
2"	NC608-1	-	NC608-2	NF608-2	-	-	-	-	NC608-3	NF608-3	
2-1/4	NC609-1	-	NC609-2	NF609-2	-	-	-	-	-	-	
2-1/2	NC610-1	-	NC610-2	NF610-2	-	-	-	-	NC610-3	NF610-3	
2-3/4	NC611-1	-	NC611-2	NF611-2	-	-	-	-	-	-	
3"	NC612-1	-	NC612-2	NF612-2	-	-	-	-	NC612-3	NF612-3	
3-1/4	NC613-1	-	NC613-2	NF613-2	-	-	-	-	-	-	
3-1/2	NC614-1	-	NC614-2	NF614-2	-	-	-	-	-	-	
3-3/4	NC615-1	-	NC615-2	NF615-2	-	-	-	-	-	-	
4"	NC616-1	-	NC616-2	NF616-2	-	-	-	-	NC616-3	NF616-3	
4-1/2	NC618-1	-	NC618-2	NF618-2	-	-	-	-	-	-	
5"	NC620-1	-	NC620-2	NF620-2	-	-	-	-	-	-	
5-1/2	NC621-1	-	NC621-2	NF621-2	-	-	-	-	-	-	
6"	NC622-1	-	NC622-2	NF622-2	-	-	-	-	-	-	
6-1/2	NC623-1	-	-	-	NC623-2B	NF623-2B	-	-	-	-	1
7"	NC624-1	-	<i>Bolts over 6 inch in Black finish only →</i>		NC624-2B	NF624-2B	-	-	-	-	
8"	NC626-1	-	-	-	NC626-2B	NF626-2B	-	-	-	-	

\*Sizes over 6" are unplated. †Zinc plated through 6" long. All lengths measured from under head.  
 Sizes not listed may be available as a special order (subject to minimum packaging).

# Hex Head Cap Screws



**GRADE 5  
CAP SCREWS**



**GRADE 8 HEX  
CAP SCREWS**



**GRADE 8 HEX  
CAP SCREWS**



**GRADE 8 HEX  
FLANGE SCREWS**



**GRADE L9 HEX  
CAP SCREWS**

LENGTH	ZINC†	ZINC DICHROMATE		BLACK		BLACK		ZINC DICHROMATE		Pkg Qty
	COARSE	COARSE	FINE	COARSE	FINE	COARSE	FINE	COARSE	FINE	

## 5/8" DIAMETER 5/8-11 COARSE (NC), 5/8-18 FINE (NF) WRENCH SIZE: 15/16"

1"	NC704-1	NC704-2	NF704-2	NC704-2B	-	-	-	-	-	50
1-1/4	NC705-1	NC705-2	NF705-2	NC705-2B	-	-	-	-	-	
1-1/2	NC706-1	NC706-2	NF706-2	NC706-2B	-	9-214(10)	9-613 <sup>(10)</sup>	NC706-3	NF706-3	25
1-3/4	NC707-1	NC707-2	NF707-2	NC707-2B	-	9-215(10)	9-614 <sup>(10)</sup>	NC707-3	NF707-3	
2"	NC708-1	NC708-2	NF708-2	NC708-2B	-	9-216(10)	9-615 <sup>(10)</sup>	NC708-3	NF708-3	
2-1/4	NC709-1	NC709-2	NF709-2	NC709-2B	-	9-217(10)	9-616 <sup>(10)</sup>	NC709-3	-	
2-1/2	NC710-1	NC710-2	NF710-2	NC710-2B	-	9-218(10)	9-617 <sup>(10)</sup>	NC710-3	NF710-3	
2-3/4	NC711-1	NC711-2	NF711-2	-	-	9-219(10)	9-618 <sup>(10)</sup>	NC711-3	-	
3"	NC712-1	NC712-2	NF712-2	NC712-2B	-	9-220(10)	9-619 <sup>(10)</sup>	NC712-3	NF712-3	
3-1/4	NC713-1	NC713-2	-	-	-	9-221(10)	-	-	-	
3-1/2	NC714-1	NC714-2	NF714-2	NC714-2B	-	9-222(10)	-	NC714-3	NF714-3	
3-3/4	NC715-1	NC715-2	NF715-2	-	-	-	-	-	-	
4"	NC716-1	NC716-2	NF716-2	NC716-2B	-	-	-	NC716-3	NF716-3	
4-1/2	NC718-1	NC718-2	NF718-2	NC718-2B	-	-	-	-	-	
5"	NC720-1	NC720-2	NF720-2	NC720-2B	-	-	-	NC720-3	NF720-3	
5-1/2	NC721-1	NC721-2	NF721-2	NC721-2B	-	-	-	-	-	
6"	NC722-1	NC722-2	NF722-2	NC722-2B	-	-	-	NC722-3	NF722-3	
6-1/2	NC723-1*	-	-	NC723-2B	-	-	-	-	-	1
7"	NC724-1*	-	-	NC724-2B	NF724-2B	-	-	NC724-3 <sup>(25)</sup>	NF724-3 <sup>(25)</sup>	
7 1/2"	NC725-1*	-	-	NC725-2B	-	-	-	-	-	
8"	NC726-1*	-	-	NC726-2B	NF726-2B	-	-	NC726-3 <sup>(25)</sup>	NF726-3 <sup>(25)</sup>	
8-1/2"	NC727-1*	-	-	NC727-2B	-	-	-	-	-	
9"	NC728-1*	-	-	NC728-2B	-	-	-	-	-	
10"	NC730-1*	-	-	NC730-2B	-	-	-	-	-	
11"	NC732-1*	-	-	NC732-2B	-	-	-	-	-	
12"	NC734-1*	-	-	NC734-2B	-	-	-	-	-	

## 3/4" DIAMETER 3/4-10 COARSE (NC), 3/4-16 FINE (NF) WRENCH SIZE: 1-1/8"

1"	NC804-1	NC804-2	-	-	-	-	-	-	-	25
1-1/4	NC805-1	NC805-2	NF805-2	-	-	-	-	-	-	
1-1/2	NC806-1	NC806-2	NF806-2	NC806-2B	-	-	-	-	-	
1-3/4	NC807-1	NC807-2	NF807-2	NC807-2B	-	-	-	-	-	
2"	NC808-1	NC808-2	NF808-2	NC808-2B	-	9-600 <sup>(10)</sup>	-	NC808-3 <sup>(20)</sup>	NF808-3 <sup>(20)</sup>	
2-1/4	NC809-1	NC809-2	NF809-2	NC809-2B	-	9-601 <sup>(10)</sup>	-	NC809-3 <sup>(20)</sup>	-	
2-1/2	NC810-1	NC810-2	NF810-2	NC810-2B	-	9-602 <sup>(10)</sup>	-	NC810-3 <sup>(20)</sup>	NF810-3 <sup>(20)</sup>	
2-3/4	NC811-1	NC811-2	NF811-2	-	-	9-603 <sup>(10)</sup>	-	NC811-3 <sup>(20)</sup>	-	
3"	NC812-1	NC812-2	NF812-2	NC812-2B	-	-	-	NC812-3 <sup>(20)</sup>	NF812-3 <sup>(20)</sup>	
3-1/4	NC813-1	NC813-2	-	-	-	-	-	-	-	
3-1/2	NC814-1	NC814-2	NF814-2	NC814-2B	-	-	-	NC814-3 <sup>(20)</sup>	-	
3-3/4	NC815-1	NC815-2	-	-	-	-	-	-	-	
4"	NC816-1	NC816-2	NF816-2	NC816-2B	-	-	-	NC816-3 <sup>(20)</sup>	NF816-3 <sup>(20)</sup>	12
4-1/2	NC818-1	NC818-2	NF818-2	NC818-2B	-	-	-	NC818-3 <sup>(20)</sup>	NF818-3 <sup>(20)</sup>	
5"	NC820-1	NC820-2	NF820-2	NC820-2B	-	-	-	NC820-3 <sup>(20)</sup>	NF820-3 <sup>(20)</sup>	
5-1/2	NC821-1	NC821-2	NF821-2	NC821-2B	-	-	-	-	-	
6"	NC822-1	NC822-2	NF822-2	NC822-2B	-	-	-	NC822-3 <sup>(20)</sup>	NF822-3 <sup>(20)</sup>	
6-1/2	NC823-1*	-	-	NC823-2B	-	-	-	-	-	1
7"	NC824-1*	-	-	NC824-2B	NF824-2B	-	-	NC824-3 <sup>(20)</sup>	NF824-3 <sup>(20)</sup>	
7-1/2	NC825-1*	-	-	NC825-2B	-	-	-	-	-	
8"	NC826-1*	-	-	NC826-2B	NF826-2B	-	-	NC826-3 <sup>(20)</sup>	NF826-3 <sup>(20)</sup>	
8-1/2	NC827-1*	<i>Bolts over 6 inch in Black finish only →</i>	-	NC827-2B	-	-	-	-	-	
9"	NC828-1*	-	-	NC828-2B	-	-	-	-	-	
10"	NC830-1*	-	-	NC830-2B	-	-	-	-	-	
11"	NC832-1*	-	-	NC832-2B	-	-	-	-	-	
12"	NC834-1*	-	-	NC834-2B	-	-	-	-	-	

\*Sizes over 6" are unplated. †Zinc plated through 6" long. All lengths measured from under head.

Sizes not listed may be available as a special order (subject to minimum packaging).



# Hex Head Cap Screws



LENGTH	ZINC†		ZINC DICHROMATE		BLACK		ZINC DICHROMATE		Pkg Qty	
	COARSE	COARSE	FINE	COARSE	FINE	COARSE	FINE			
<b>7/8" DIAMETER</b> 7/8-9 COARSE (NC), 7/8-14 FINE (NF) WRENCH SIZE: 15/16"										
1-1/2	NC906-1	NC906-2	-	-	-	-	-	-	25	
1-3/4	NC907-1	NC907-2	-	-	-	-	-			
2"	NC908-1	NC908-2	NF908-2	NC908-2B	-	-	-			
2-1/4	NC909-1	NC909-2	NF909-2	-	-	-	-			
2-1/2	NC910-1	NC910-2	NF910-2	NC910-2B	-	-	-	12		
2-3/4	NC911-1	NC911-2	NF911-2	-	-	-	-			
3"	NC912-1	NC912-2	NF912-2	NC912-2B	-	NC912-3 <sub>(15)</sub>	NF912-3 <sub>(15)</sub>			
3-1/4	NC913-1	NC913-2	-	-	-	-	-			
3-1/2	NC914-1	NC914-2	NF914-2	NC914-2B	-	NC914-3 <sub>(15)</sub>	-			
3-3/4	NC915-1	NC915-2	-	-	-	-	-			
4"	NC916-1	NC916-2	NF916-2	NC916-2B	-	NC916-3 <sub>(15)</sub>	NF916-3 <sub>(15)</sub>			
4-1/2	NC918-1	NC918-2	NF918-2	NC918-2B	-	NC918-3 <sub>(15)</sub>	-			
5"	NC920-1	NC920-2	NF920-2	NC920-2B	-	-	-			
5-1/2	NC921-1	NC921-2	NF921-2	NC921-2B	-	-	-			
6"	NC922-1	NC922-2	NF922-2	NC922-2B	-	NC922-3 <sub>(15)</sub>	-			
6-1/2	NC923-1*	-	-	NC923-2B	NF923-2B	-	-		1	
7"	NC924-1*	-	-	NC924-2B	NF924-2B	-	-			
7 1/2"	NC925-1*	-	-	NC925-2B	-	-	-			
8"	NC926-1*	<i>Bolts over 6 inch in Black finish only →</i>		NC926-2B	NF926-2B	-	-			
9"	NC928-1*	-	-	NC928-2B	-	-	-			
10"	NC930-1*	-	-	NC930-2B	-	-	-			
11"	NC932-1*	-	-	NC932-2B	-	-	-			
12"	NC934-1*	-	-	NC934-2B	-	-	-			
<b>1" DIAMETER</b> 1-8 COARSE (NC), 1-14 FINE (NF) WRENCH SIZE: 1-1/8"										
1-1/2	NC1006-1	NC1006-2	-	-	-	-	-	12		
1-3/4	NC1007-1	NC1007-2	NF1007-2	-	-	-	-			
2"	NC1008-1	NC1008-2	NF1008-2	NC1008-2B	-	-	-			
2-1/4	NC1009-1	NC1009-2	NF1009-2	-	-	-	-			
2-1/2	NC1010-1	NC1010-2	NF1010-2	NC1010-2B	-	-	-			
2-3/4	NC1011-1	NC1011-2	NF1011-2	-	-	-	-			
3"	NC1012-1	NC1012-2	NF1012-2	NC1012-2B	-	NC1012-3 <sub>(10)</sub>	NF1012-3 <sub>(10)</sub>			
3-1/4	NC1013-1	NC1013-2	-	-	-	-	-			
3-1/2	NC1014-1	NC1014-2	NF1014-2	NC1014-2B	-	-	-			
3-3/4	NC1015-1	NC1015-2	-	-	-	-	-			
4"	NC1016-1	NC1016-2	NF1016-2	NC1016-2B	-	NC1016-3 <sub>(10)</sub>	NF1016-3 <sub>(10)</sub>			
4-1/2	NC1018-1	NC1018-2	NF1018-2	NC1018-2B	-	NC1018-3 <sub>(10)</sub>	NF1018-3 <sub>(10)</sub>			
5"	NC1020-1	NC1020-2	NF1020-2	NC1020-2B	-	NC1020-3 <sub>(10)</sub>	NF1020-3 <sub>(10)</sub>			
5-1/2	NC1021-1	NC1021-2	NF1021-2	NC1021-2B	-	-	-			
6"	NC1022-1	NC1022-2	NF1022-2	NC1022-2B	-	NC1022-3 <sub>(10)</sub>	NF1022-3 <sub>(10)</sub>			
6-1/2	NC1023-1*	-	-	NC1023-2B	NF1023-2B	-	-	1		
7"	NC1024-1*	-	-	NC1024-2B	NF1024-2B	NC1024-3 <sub>(10)</sub>	NF1024-3 <sub>(10)</sub>			
7-1/2	NC1025-1*	-	-	NC1025-2B	NF1025-2B	-	-			
8"	NC1026-1*	<i>Bolts over 6 inch in Black finish only →</i>		NC1026-2B	NF1026-2B	NC1026-3 <sub>(10)</sub>	NF1026-3 <sub>(10)</sub>			
8-1/2	NC1027-1*	-	-	NC1027-2B	NF1027-2B	-	-			
9"	NC1028-1*	-	-	NC1028-2B	NF1028-2B	-	-			
10"	NC1030-1*	-	-	NC1030-2B	NF1030-2B	NC1030-3 <sub>(8)</sub>	-			
11"	NC1032-1*	-	-	NC1032-2B	NF1032-2B	-	-			
12"	NC1034-1*	-	-	NC1034-2B	NF1034-2B	-	-			

\*Sizes over 6" are unplated. †Zinc plated through 6" long. All lengths measured from under head.

Sizes not listed may be available as a special order (subject to minimum packaging).

# Hex Head Cap Screws



**GRADE 5 HEX  
CAP SCREWS**



**GRADE 8  
HEX CAP SCREWS**



**GRADE L9  
HEX CAP SCREWS**

LENGTH	BLACK	BLACK		ZINC DICHROMATE		PKG QTY
	COARSE	COARSE	FINE	COARSE	FINE	
<b>1-1/8" DIAMETER</b> 1-1/8-7 COARSE (NC), 1-1/8-12 FINE (NF) WRENCH SIZE: 1-11/16"						
2"	NC1108-1	NC1108-2B	-	-	-	12
2-1/2	NC1110-1	NC1110-2B	-	-	-	
3"	NC1112-1	NC1112-2B	-	-	-	
3-1/2	-	NC1114-2B	NF1114-2B	-	-	
4"	NC1116-1	NC1116-2B	NF1116-2B	NC1116-3	NF1116-3	
4-1/2	-	NC1118-2B	-	-	-	6
5"	NC1120-1	NC1120-2B	NF1120-2B	NC1120-3	NF1120-3	
6"	NC1122-1	NC1122-2B	NF1122-2B	NC1122-3	NF1122-3	
6-1/2	NC1123-1	NC1123-2B	-	-	-	
7"	NC1124-1	NC1124-2B	NF1124-2B	NC1124-3	NF1124-3	
8"	NC1126-1	NC1126-2B	NF1126-2B	-	-	
10"	-	NC1130-2B	-	-	-	1
<b>1-1/4" DIAMETER</b> 1-1/4-7 COARSE (NC), 1-1/4-12 FINE (NF) WRENCH SIZE: 1-7/8"						
3"	-	NC1212-2B	-	-	-	12
3-1/2	-	NC1214-2B	-	-	-	
4"	NC1216-1	NC1216-2B	NF1216-2B	NC1216-3	NF1216-3	
4-1/2	-	NC1218-2B	-	-	-	
5"	NC1220-1	NC1220-2B	NF1220-2B	NC1220-3	NF1220-3	6
5-1/2	-	NC1221-2B	-	-	-	
6"	NC1222-1	NC1222-2B	NF1222-2B	NC1222-3	NF1222-3	
6-1/2	-	NC1223-2B	-	-	-	
7"	NC1224-1	NC1224-2B	NF1224-2B	NC1224-3	NF1224-3	
7-1/2	-	NC1225-2B	NF1225-2B	-	-	
8"	NC1226-1	NC1226-2B	NF1226-2B	NC1226-3	-	
8-1/2	-	NC1227-2B	-	-	-	
9"	-	NC1228-2B	-	-	-	
10"	NC1230-1	NC1230-2B	NF1230-2B	-	-	
11"	NC1232-1	NC1232-2B	-	-	-	1
12"	-	NC1234-2B	-	-	-	
<b>1-1/2" DIAMETER</b> 1-1/2-6 COARSE (NC), 1-1/2-12 FINE (NF) WRENCH SIZE: 2-1/4"						
4"	-	NC1416-2B	-	-	-	1
5"	-	NC1420-2B	-	-	-	
6"	NC1422-1	NC1422-2B	NF1422-2B	-	-	
7"	-	NC1424-2B	-	-	-	
8"	NC1426-1	NC1426-2B	NF1426-2B	-	-	
10"	NC1430-1	NC1430-2B	NF1430-2B	-	-	
12"	-	NC1434-2B	NF1434-2B	-	-	

All lengths measured from under head.

Sizes not listed may be available as a special order (subject to minimum packaging).



# Hex Head Cap Screw Assortments



Base optional (#98-BBC)

1/4 NUT	5/16 NUT	3/8 NUT	7/16 NUT	1/2 NUT	9/16 NUT	5/8 NUT	3/4 NUT
1/4 FLAT	5/16 FLAT	3/8 FLAT	7/16 FLAT	1/2 FLAT	9/16 FLAT	5/8 FLAT	3/4 FLAT
1/4 LOCK	5/16 LOCK	3/8 LOCK	7/16 LOCK	1/2 LOCK	9/16 LOCK	5/8 LOCK	3/4 LOCK
1/4 X 1/2	5/16 X 1/2	3/8 X 3/4	7/16 X 1	1/2 X 1	9/16 X 1-1/4	5/8 X 1-1/4	3/4 X 1-1/2
1/4 X 3/4	5/16 X 3/4	3/8 X 1	7/16 X 1-1/4	1/2 X 1-1/2	9/16 X 1-1/2	5/8 X 1-1/2	3/4 X 2
1/4 X 1	5/16 X 1	3/8 X 1-1/4	7/16 X 1-1/2	1/2 X 2	9/16 X 2	5/8 X 2	3/4 X 2-1/2
1/4 X 1-1/4	5/16 X 1-1/4	3/8 X 1-1/2	7/16 X 2	1/2 X 2-1/2	9/16 X 2-1/2	5/8 X 2-1/2	3/4 X 3
1/4 X 1-1/2	5/16 X 1-1/2	3/8 X 2	7/16 X 2-1/2	1/2 X 3	9/16 X 3	5/8 X 3	3/4 X 3-1/2
1/4 X 2	5/16 X 2	3/8 X 2-1/2	7/16 X 3	1/2 X 3-1/2	9/16 X 3-1/2	5/8 X 3-1/2	3/4 X 4

Layout for Assortments 72-100, 72-104 and 72-106

**72-100 GRADE 5 NC CAP SCREW ASSORTMENT** Coarse threads. Sizes 1/4 thru 3/4 dia. up to 4" long. Includes Hex Nuts, USS Flat Washers and Lock Washers in a labeled 72 hole steel bin. .... **72 sizes**  
 72-100R GRADE 5 ASSORTMENT REFILL for 72-100 or 80-100. .... **72 sizes**

**80-100 GRADE 5 NC CAP SCREW ASSORTMENT** Coarse threads. Same as 72-100 except includes 2 labeled 40 hole steel bins. 8 compartments are empty for future expansion. .... **72 sizes**

**72-110 GRADE 5 NC CAP SCREW ASSORTMENT** Coarse threads. Sizes 1/4 thru 3/4 dia. up to 6" long. Includes Hex Nuts, USS Flat Washers and Lock Washers in a labeled 72 hole steel bin. .... **72 sizes**  
 72-110R GRADE 5 ASSORTMENT REFILL for 72-110 or 80-110. .... **72 sizes**

**80-110 GRADE 5 NC CAP SCREW ASSORTMENT** Coarse threads. Same as 72-110 except includes 2 labeled 40 hole steel bins. 8 compartments are empty for future expansion. .... **72 sizes**

**72-104 GRADE 8 ALLOY NC CAP SCREW ASSORTMENT** Coarse threads. Sizes 1/4 thru 3/4 dia. up to 4" long. Includes Hex Nuts, USS Flat Washers and Lock Washers in a labeled 72 hole steel bin. .... **72 sizes**

**80-104 GRADE 8 ALLOY NC CAP SCREW ASSORTMENT** Coarse threads. Same as 80-104 except includes 2 labeled 40 hole steel bins. 8 compartments are empty for future expansion. .... **72 sizes**

**72-106 GRADE 8 ALLOY NF CAP SCREW ASSORTMENT** Fine threads. Sizes 1/4 thru 3/4 dia. up to 4" long. Includes Hex Nuts, SAE Flat Washers and Lock Washers in a labeled 72 hole steel bin. .... **72 sizes**



**16-0124 GRADE 5 NC CAP SCREW DRAWER ASSORTMENT** Coarse threads. Sizes 1/4 thru 1/2" dia. up to 3" lg. Includes Hex Nuts in a 24 hole steel drawer. .... **24 sizes**

**16-6524 GRADE 8 NC CAP SCREW DRAWER ASSORTMENT** Coarse threads. Sizes 1/4 thru 1/2" dia. up to 3" lg. Includes Hex Nuts in a 24 hole steel drawer. .... **24 sizes**

**16-6624 GRADE 8 NF CAP SCREW DRAWER ASSORTMENT** Fine threads. Sizes 1/4 thru 1/2" dia. up to 3" lg. Includes Hex Nuts in a 24 hole steel drawer. .... **24 sizes**



# Hex Head Cap Screw Assortments

1/4 NUT	1/4 FLAT	1/4 LOCK	1/4 X 3/4	1/4 X 1	1/4 X 1-1/4	1/4 X 1-1/2	1/4 X 2
5/16 NUT	5/16 FLAT	5/16 LOCK	5/16 X 3/4	5/16 X 1	5/16 X 1-1/4	5/16 X 1-1/2	5/16 X 2
3/8 NUT	3/8 FLAT	3/8 LOCK	3/8 X 1	3/8 X 1-1/4	3/8 X 1-1/2	3/8 X 2	3/8 X 2-1/2
7/16 NUT	7/16 FLAT	7/16 LOCK	7/16 X 1	7/16 X 1-1/4	7/16 X 1-1/2	7/16 X 2	7/16 X 2-1/2
1/2 NUT	1/2 FLAT	1/2 LOCK	1/2 X 1	1/2 X 1-1/2	1/2 X 2	1/2 X 2-1/2	1/2 X 3

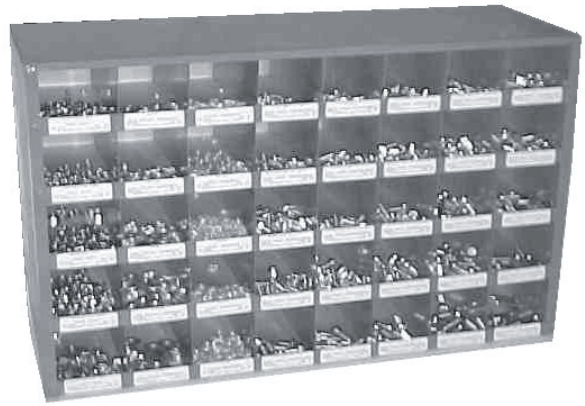

Assortment layout for 40-100, 40-102 and 40-103

**40-100 GRADE 5 NC CAP SCREW ASSORTMENT** Coarse threads. Sizes 1/4 thru 1/2 dia. up to 3" long. Includes Hex Nuts, USS Flat Washers and Lock Washers in a labeled 40 hole steel bin. .... **40 sizes**  
 40-100R GRADE 5 ASSORTMENT REFILL for 40-100. .... 40 sizes, 2810 pcs.

**40-102 GRADE 8 ALLOY NC CAP SCREW ASSORTMENT** Coarse threads. Sizes 1/4 thru 1/2 dia. up to 3" long. Includes Hex Nuts, USS Flat Washers and Lock Washers in a labeled 40 hole steel bin. .... **40 sizes**

**40-103 GRADE 8 ALLOY NF CAP SCREW ASSORTMENT** Fine threads. Sizes 1/4 thru 1/2 dia. up to 3" long. Includes Hex Nuts, SAE Flat Washers and Lock Washers in a labeled 40 hole steel bin. .... **40 sizes**

## WE CAN CUSTOMIZE ANY ASSORTMENT TO FIT YOUR NEEDS!

1/4 NUT	5/16 NUT	3/8 NUT	7/16 NUT	1/2 NUT	9/16 HEX NUT	5/8 HEX NUT	3/4 NUT
1/4 FLAT	5/16 FLAT	3/8 FLAT	7/16 FLAT	1/2 FLAT	9/16 FLAT	5/8 FLAT	3/4 FLAT
1/4 LOCK	5/16 LOCK	3/8 LOCK	7/16 LOCK	1/2 LOCK	9/16 LOCK	5/8 LOCK	3/4 LOCK
1/4 X 1/2	5/16 X 3/4	3/8 X 1	7/16 X 1-1/2	1/2 X 1-1/2	9/16 X 2	5/8 X 2	3/4 X 2
1/4 X 1	5/16 X 1	3/8 X 1-1/2	7/16 X 2	1/2 X 2	9/16 X 2-1/2	5/8 X 2-1/2	3/4 X 2-1/2
1/4 X 1-1/2	5/16 X 1-1/2	3/8 X 2	7/16 X 2-1/2	1/2 X 2-1/2	9/16 X 3	5/8 X 3	3/4 X 3
1/4 X 2	5/16 X 2	3/8 X 2-1/2	7/16 X 3	1/2 X 3	9/16 X 3-1/2	5/8 X 4	3/4 X 4
1/4 X 2-1/2	5/16 X 2-1/2	3/8 X 3	7/16 X 4	1/2 X 4	9/16 X 4	5/8 X 5	3/4 X 5
1/4 X 3	5/16 X 3	3/8 X 4	7/16 X 5	1/2 X 5	1/2 X 6	5/8 X 6	3/4 X 6

Layout for 72-110 Assortment

1/4 NUT	5/16 NUT	3/8 NUT	7/16 NUT	1/2 NUT	9/16 NUT	5/8 NUT	3/4 NUT
1/4 X 1/2	5/16 X 1/2	3/8 X 3/4	7/16 X 3/4	1/2 X 1	9/16 X 1-1/4	5/8 X 1-1/2	3/4 X 2
1/4 X 3/4	5/16 X 3/4	3/8 X 1	7/16 X 1	1/2 X 1-1/2	9/16 X 1-1/2	5/8 X 2	3/4 X 2-1/2
1/4 X 1	5/16 X 1	3/8 X 1-1/2	7/16 X 1-1/2	1/2 X 2	9/16 X 2	5/8 X 2-1/2	3/4 X 3
1/4 X 1-1/4	5/16 X 1-1/4	3/8 X 2	7/16 X 2	1/2 X 2-1/2	9/16 X 2-1/2	5/8 X 3	3/4 X 3-1/2
1/4 X 1-1/2	5/16 X 1-1/2	3/8 X 2-1/2	7/16 X 2-1/2	1/2 X 3	9/16 X 3	5/8 X 3-1/2	3/4 X 4
1/4 X 2	5/16 X 2	3/8 X 3	7/16 X 3	1/2 X 3-1/2	9/16 X 3-1/2	5/8 X 4	3/4 X 4-1/2
1/4 X 2-1/2	5/16 X 2-1/2	3/8 X 3-1/2	7/16 X 3-1/2	1/2 X 4	9/16 X 4	5/8 X 4-1/2	3/4 X 5
1/4 X 3	5/16 X 3	3/8 X 4	7/16 X 4	1/2 X 5	9/16 X 5	5/8 X 5	3/4 X 6

Layout for 72-105 Assortment



# Torque Guide

This table provides an estimate of torque required to induce corresponding clamp load in a bolt for non-critical, plated bolt, nut and washer assemblies (not tapped holes). Consult a qualified engineer for critical applications since many variables affect final assembly torque.



SIZE	GRADE 5 PLATED COMPONENTS <sup>†</sup>		GRADE 8 PLATED COMPONENTS <sup>†</sup>		GRADE L9 PLATED COMPONENTS <sup>†</sup>	
	CLAMP LOAD	TORQUE <sup>‡</sup>	CLAMP LOAD	TORQUE <sup>‡</sup>	CLAMP LOAD	TORQUE <sup>‡</sup>
1/4-20 (UNC)	2,025	6 ft. lbs.	2,850	9 ft. lbs.	3,450	11 ft. lbs.
1/4-28 (UNF)	2,325	7 ft. lbs.	3,263	10 ft. lbs.	3,950	13 ft. lbs.
5/16-18 (UNC)	3,338	13 ft. lbs.	4,725	18 ft. lbs.	5,700	21 ft. lbs.
5/16-24 (UNF)	3,675	14 ft. lbs.	5,113	20 ft. lbs.	6,300	23 ft. lbs.
3/8-16 (UNC)	4,950	23 ft. lbs.	6,975	33 ft. lbs.	8,450	33 ft. lbs.
3/8-24 (UNF)	5,588	26 ft. lbs.	7,785	37 ft. lbs.	9,550	38 ft. lbs.
7/16-14 (UNC)	6,788	37 ft. lbs.	9,600	52 ft. lbs.	11,550	60 ft. lbs.
7/16-20 (UNF)	7,575	41 ft. lbs.	10,650	58 ft. lbs.	12,900	65 ft. lbs.
1/2-13 (UNC)	9,075	57 ft. lbs.	12,750	80 ft. lbs.	15,450	95 ft. lbs.
1/2-20 (UNF)	10,200	64 ft. lbs.	14,400	90 ft. lbs.	17,400	105 ft. lbs.
9/16-12 (UNC)	11,625	82 ft. lbs.	16,350	115 ft. lbs.	19,800	140 ft. lbs.
9/16-18 (UNF)	12,975	91 ft. lbs.	18,300	129 ft. lbs.	22,100	150 ft. lbs.
5/8-11 (UNC)	14,400	112 ft. lbs.	20,325	159 ft. lbs.	24,550	185 ft. lbs.
5/8-18 (UNF)	16,350	128 ft. lbs.	23,125	180 ft. lbs.	27,800	205 ft. lbs.
3/4-10 (UNC)	21,300	200 ft. lbs.	30,075	282 ft. lbs.	36,350	290 ft. lbs.
3/4-16 (UNF)	23,775	223 ft. lbs.	33,600	315 ft. lbs.	40,600	355 ft. lbs.
7/8-9 (UNC)	29,475	322 ft. lbs.	41,550	454 ft. lbs.	50,300	505 ft. lbs.
7/8-14 (UNF)	32,475	355 ft. lbs.	45,825	501 ft. lbs.	55,400	585 ft. lbs.
1-8 (UNC)	38,625	483 ft. lbs.	54,525	682 ft. lbs.	65,900	775 ft. lbs.
1-14 (UNF)	42,300	541 ft. lbs.	61,125	764 ft. lbs.	73,800	900 ft. lbs.
1-1/8-7 (UNC)	42,375	596 ft. lbs.	68,700	966 ft. lbs.	83,000	1,150 ft. lbs.
1-1/8-12 (UNF)	47,475	668 ft. lbs.	77,025	1,083 ft. lbs.	93,100	1,325 ft. lbs.
1-1/4-7 (UNC)	53,775	840 ft. lbs.	87,225	1,363 ft. lbs.	105,400	1,600 ft. lbs.
1-1/4-12 (UNF)	59,550	930 ft. lbs.	96,600	2,012 ft. lbs.	116,700	1,750 ft. lbs.

<sup>†</sup>Above values are for zinc plated (dry, unlubricated) nut and bolt assemblies.  
 Increase torque by 33% if using unplated (dry, unlubricated) nut and bolt assemblies.  
 Decrease torque by 45% if using lubricants (oil, grease, or antiseize lubricant).









**MADE IN U.S.A.**

Maintenance products uses only domestic manufacturers whenever possible.  
 When a domestic source is unavailable, only importers with impeccable reputations are used.

# Mechanical Properties & Grade Markings

## for common Hex Head Cap Screws

Identification Grade Markings	Specification	Material (AISI)	Nominal Size Range (In.)	Proof Load Stress	Yield Strength (Min.)	Tensile Strength (Min.)	Rockwell Hardness
 GRADE 2 No markings	SAE J 429	1006, 1008, 1016, 1018, 1021, 1022 Low Carbon Steel	1/4 thru 3/4" Over 3/4 thru 1-1/2"	55,000 PSI 33,000 PSI	57,000 PSI 36,000 PSI	74,000 PSI 60,000 PSI	B80-100
 GRADE 5 3 radial lines	SAE J 429 ASTM A449 ASME/ANSI B18.2-1	1030, 1035, 1038, 1541 Carbon Steel Quenched & Tempered	1/4 thru 1" Over 1" thru 1-1/2"	85,000 PSI 74,000 PSI	92,000 PSI 81,000 PSI	120,000 PSI 105,000 PSI	C25-34
 GRADE 8 6 radial lines	SAE J 429 ASTM 354 ASME/ANSI B18.2-1	1335, 4037, 4140, 4140, 4340, 8637, 8740 Medium Carbon Alloy Steel Quenched & Tempered	1/4 thru 1-1/2"	120,000 PSI	130,000 PSI	150,000 PSI	C33-39
 L9 <sup>®</sup> Hex Screws 9 radial lines	Not listed Exceeds SAE Grade 8 specifications	4140 Modified Alloy Steel Quenched & Tempered	1/4 thru 1-1/2"	145,000 PSI	155,000 PSI	180,000 PSI	C38-42
 PROPERTY CLASS 8.8 Marked 8 or 8.8	ISO R898 Class 8.8	Carbon Steel Quenched & Tempered	Up to M16 Over M16	84,100 PSI 87,000 PSI	92,800 PSI 95,700 PSI	116,000 PSI 120,000 PSI	C20-30 C23-34
 PROPERTY CLASS 10.9 Marked 10 or 10.9	ISO R898 Class 10.9	Alloy Steel Quenched & Tempered	M3 thru M24	121,800 PSI	136,300 PSI	150,800 PSI	C31-39

**SPECIAL BOLTS? EXOTIC ALLOYS? UNLISTED SIZES?**

Small run custom modified bolts and nuts can be a real headache.

Why not let us do the legwork? We *specialize* in specials!

**CALL US FOR CUSTOM BOLTS!**



# Socket Screw Products

## SOCKET HEAD CAP SCREWS (1960 Series)



A heat-treated alloy steel fastener manufactured in accordance with AISI and IFI standards. Close tolerance class 3A thread fit. Deep, smooth hex recess for easy wrenching. Length is measured from base of head. *Thread lengths: Under 6" long, twice the diameter +1/4". Sizes 6" and longer, twice the diameter +1/2". Sizes too short for this formula are fully threaded.*

Min. Tensile Strength: 180,000 p.s.i. thru 1/2", 170,000 p.s.i. over 1/2"  
Material: Medium carbon C1038 alloy steel      Hardness: Rockwell C37-43  
Finish: Black oxide coated      Meets ANSI/ASME B18.3, ASTM A574

## FLAT HEAD SOCKET CAP SCREWS



A heat-treated alloy steel screw with 82° countersink. Manufactured in accordance with AISI and IFI standards. Close tolerance class 3A thread fit. Deep, smooth hex recess for easy wrenching. Length is measured from top of head (overall length). *Thread length is twice the diameter +1/4". Sizes too short for this formula are fully threaded.*

Min. Tensile Strength: 180,000 p.s.i.      Hardness: Rockwell C38-44  
Material: Medium carbon C1038 alloy steel      Meets ANSI/ASME B18.3, ASTM F835  
Finish: Black oxide coated      Countersink: 82°

## BUTTON HEAD SOCKET CAP SCREWS



A heat-treated alloy steel screw made in accordance with AISI and IFI standards. Button heads are used where a wider bearing surface or low profile head is required. Close tolerance class 3A thread fit. Deep, smooth hex recess for easy wrenching. Length is measured from base of head. *Thread length is twice the diameter +1/4". Sizes too short for this formula are fully threaded.*

Min. Tensile Strength: 180,000 p.s.i.      Hardness: Rockwell C38-44  
Material: Medium carbon C1038 alloy steel      Meets ANSI/ASME B18.3, ASTM F835  
Finish: Black oxide coated

## 12-POINT COUNTERBORE SCREWS



Also known as high torque cap screws, flange screws and starter bolts. 12-point flange screws can be used to replace socket head cap screws, eliminating the need for hex key wrenches. Drive by using a 12-point socket or wrench of the same size as screw diameter. Use with high-collar lock washers. Made in accordance with AISI and IFI standards. Close tolerance class 3A thread fit. Length is measured from under base of flange. *Thread length is twice the diameter +1/4". Sizes too short for this formula are fully threaded.*

Min. Tensile Strength: 170,000 p.s.i.      Hardness: Rockwell C37-43  
Material: Medium carbon C1038 alloy steel      Meets ANSI/ASME B18.3, ASTM F835  
Finish: Black oxide coated

## SQUARE HEAD SET SCREWS



Square head set screws are case hardened fully threaded screws commonly used as a quick adjusting screw or locking screw on a shaft. Also available in alloy steel. Class 2B thread fit. Length is measured from under head. *Fully threaded.*

Min. Tensile Strength: 120,000 p.s.i.      Hardness: n/a  
Material: Low carbon steel (case hardened)      Meets ANSI/ASME B18.6.2  
Finish: plain, uncoated      Point style: Cup

## SOCKET SET SCREWS



Socket set screws are heat-treated alloy steel screws made in accordance with AISI and IFI standards. Currently stocked in cup point (most used), half-dog point (permanent setting) or knurled point (extra holding power). Many other point styles are available on request. Class 2B thread fit. Deep, smooth hex recess for easy wrenching. Length is measured from under head. *Fully threaded.*

Min. Tensile Strength: 245,000 p.s.i.      Hardness: Rockwell C43-53  
Material: Medium carbon C1038 alloy steel      Meets ANSI/ASME B18.6.2  
Finish: Black oxide coated      Point styles: Cup, half-dog or knurled

*Certifications available on request.*

# Socket Screw Products

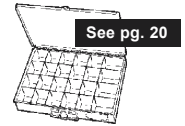

**SOCKET HEAD  
CAP SCREWS**

**FLAT HEAD  
SOCKET  
CAP SCREWS**

**BUTTON HEAD  
SOCKET  
CAP SCREWS**

**CUP POINT  
SOCKET SET  
SCREWS**

LENGTH	BLACK	BLACK	BLACK	BLACK	BLACK	BLACK	BLACK	PKG
--------	-------	-------	-------	-------	-------	-------	-------	-----

## #4 DIAMETER

	4-40 UNC	4-48 UNF	4-40 UNC	4-48 UNF	4-40 UNC	4-48 UNF	4-40 UNC	4-48 UNF	
1/4	29-009	-	-	-	28-101	-	-	-	100
3/8	29-010	-	-	-	28-102	-	-	-	
1/2	29-011	-	-	-	28-103	-	-	-	
5/8	29-012	-	-	-	-	-	-	-	
3/4	29-013	-	-	-	-	-	-	-	

## #5 DIAMETER

	5-40 UNC	5-48 UNF	5-40 UNC	5-48 UNF	5-40 UNC	5-48 UNF	5-40 UNC	5-48 UNF	
1/4	29-014	-	-	-	-	-	-	-	100
3/8	29-015	-	-	-	-	-	-	-	
1/2	29-016	-	-	-	-	-	-	-	

## #6 DIAMETER

	6-32 UNC	6-40 UNF	6-32 UNC	6-40 UNF	6-32 UNC	6-40 UNF	6-32 UNC	6-40 UNF	
1/8	-	-	-	-	-	-	28-266	-	100
3/16	-	-	-	-	-	-	28-267	28-403	
1/4	29-019	-	29-237	-	28-104	-	28-268	28-404	
5/16	-	-	-	-	-	-	28-269	-	
3/8	29-020	-	29-238	-	28-105	-	28-270	28-406	
1/2	29-021	-	29-239	-	28-106	-	28-272	-	
5/8	29-022	-	29-240	-	28-107	-	-	-	
3/4	29-023	-	29-241	-	-	-	28-274	-	
7/8	29-024	-	-	-	-	-	-	-	
1"	29-025	-	-	-	-	-	28-276	-	

## #8 DIAMETER

	8-32 UNC	8-36 UNF	8-32 UNC	8-36 UNF	8-32 UNC	8-36 UNF	8-32 UNC	8-36 UNF	
1/8	-	-	-	-	-	-	28-277	-	100
3/16	-	-	-	-	-	-	28-278	-	
1/4	29-026	-	-	-	28-108	-	28-279	28-409	
5/16	-	-	-	-	-	-	28-280	-	
3/8	29-027	-	29-242	-	28-109	-	28-281	28-411	
1/2	29-028	-	29-243	-	28-110	-	28-283	-	
5/8	29-029	-	29-244	-	28-111	-	-	-	
3/4	29-030	-	29-245	-	28-112	-	28-285	-	
7/8	29-031	-	-	-	-	-	-	-	
1"	29-032	-	29-246	-	-	-	28-287	-	
1-1/4	29-033	-	-	-	-	-	-	-	
1-1/2	29-034	-	-	-	-	-	-	-	

# Socket Screw Products



SOCKET HEAD  
CAP SCREWS



FLAT HEAD  
SOCKET  
CAP SCREWS



BUTTON HEAD  
SOCKET  
CAP SCREWS



CUP POINT  
SOCKET SET  
SCREWS



SQUARE  
HEAD SET  
SCREWS

LENGTH	BLACK		BLACK		BLACK		BLACK		BLACK	PKG
<b>#10 DIAMETER</b>										
	10-24 UNC	10-32 UNF	10-24 UNC	10-32 UNF	10-24 UNC	10-32 UNF	10-24 UNC	10-32 UNF	10-24 UNC	
3/16	-	-	-	-	-	-	28-288	28-413	-	100
1/4	-	-	-	-	28-113	28-146	28-289	28-414	-	
5/16	-	-	-	-	-	-	28-290	28-415	-	
3/8	29-035	28-009	29-247	28-071	28-114	28-147	28-291	28-416	-	
1/2	29-036	28-010	29-248	28-072	28-115	28-148	28-293	28-418	-	
5/8	29-037	28-011	29-249	28-073	28-116	28-149	-	-	-	
3/4	29-038	28-012	29-250	28-074	28-117	28-150	28-295	28-420	-	
7/8	29-039	-	-	-	28-118	28-151	-	-	-	
1"	29-040	28-014	29-251	28-075	28-119	28-152	28-297	28-421	-	
1-1/4	29-041	28-015	29-252	28-076	-	-	-	-	-	
1-1/2	29-042	28-016	29-253	28-077	-	-	-	-	-	
1-3/4	29-043	28-017	-	-	-	-	-	-	-	
2"	29-044	28-018	-	-	-	-	-	-	-	

<b>1/4" DIAMETER</b>										
	1/4-20 UNC	1/4-28 UNF	1/4-20 UNC	1/4-28 UNF	1/4-20 UNC	1/4-28 UNF	1/4-20 UNC	1/4-28 UNF	1/4-20 UNC	
3/16							28-299		-	100
1/4							28-300	28-424	-	
5/16							28-301	28-425	-	
3/8	29-045	28-019	29-254	28-078	28-120	28-153	28-302	28-426	-	
7/16							28-303	28-427	-	
1/2	29-046	28-020	29-255	28-079	28-121	28-154	28-304	28-428	-	
5/8	29-047	28-021	29-256	28-080	28-122	28-155	28-305	-	-	
3/4	29-048	28-022	29-257	28-081	28-123	28-156	28-306	28-430	28-789	
7/8	29-049	28-023	-	-	28-124	-	28-307	-	-	
1"	29-050	28-024	29-258	28-082	28-125	28-157	28-308	-	28-790	
1-1/4	29-051	28-025	29-259	28-083	-	-	28-309	-	28-791	
1-1/2	29-052	28-026	29-260	28-084	-	-	-	-	28-792	
1-3/4	29-053	28-027	29-261	-	-	-	-	-	-	
2"	29-054	28-028	29-262	-	-	-	-	-	28-794	
2-1/4	29-055	28-029	-	-	-	-	-	-	-	
2-1/2	29-056	-	-	-	-	-	-	-	28-795	
2-3/4	29-057	-	-	-	-	-	-	-	-	
3"	29-058	-	-	-	-	-	-	-	-	

## Hex Key Wrench Sizes

TYPE OF SCREW	SCREW DIAMETER															
	No.4	No.5	No.6	No.8	No.10	1/4	5/16	3/8	7/16	1/2	5/8	3/4	7/8	1"	1-1/4	1-1/2
SOCKET HEAD CAP SCREWS	3/32	3/32	7/64	9/64	5/32	3/16	1/4	5/16	3/8	3/8	1/2	5/8	3/4	3/4	7/8	1"
FLAT HEAD SOCKET C/S	1/16	5/64	5/64	3/32	1/8	5/32	3/16	3/16	1/4	5/16	3/8	1/2	-	-	-	-
BUTTON HEAD SOCKET C/S	1/16	-	5/64	3/32	1/8	5/32	3/16	3/16	-	5/16	3/8	-	-	-	-	-
SOCKET SET SCREWS	.050	1/16	1/16	5/64	3/32	1/8	5/32	5/32	7/32	1/4	5/16	3/8	1/2	9/16	-	-
SOCKETSHOULD- ER SCREWS	-	-	-	-	-	1/8	5/32	5/32	-	1/4	5/16	3/8	-	-	-	-

# Socket Screw Products

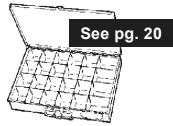

**SOCKET HEAD  
CAP SCREWS**



**FLAT HEAD  
SOCKET  
CAP SCREWS**



**BUTTON HEAD  
SOCKET  
CAP SCREWS**



**CUP POINT  
SOCKET SET  
SCREWS**



**SQUARE  
HEAD SET  
SCREWS**

LENGTH	BLACK	BLACK	BLACK	BLACK	BLACK	BLACK	BLACK	BLACK	PKG
--------	-------	-------	-------	-------	-------	-------	-------	-------	-----

## 5/16" DIAMETER

	5/16-18 UNC	5/16-24 UNF	5/16-18 UNC	5/16-24 UNF	5/16-18 UNC	5/16-24 UNF	5/16-18 UNC	5/16-24 UNF	5/16-18 UNC	
3/16	-	-	-	-	-	-	-	-	-	100
1/4	-	-	-	-	-	-	28-313	28-433	-	
5/16	-	-	-	-	-	-	28-314	28-434	-	
3/8	29-060	-	-	-	28-126	28-158	28-315	28-435	-	
1/2	29-061	28-030	29-263	28-085	28-127	28-159	28-317	28-437	-	
5/8	29-062	28-031	29-264	28-086	28-128	28-160	28-318	28-438	-	
3/4	29-063	28-032	29-265	28-087	28-129	28-161	28-319	28-439	28-800	
7/8	29-064	-	-	-	28-130	-	-	-	-	
1"	29-065	28-034	29-266	28-088	28-131	28-162	28-321	28-440	28-801	
1-1/4	29-066	28-035	29-267	28-089	-	-	28-322	-	-	
1-1/2	29-067	28-036	29-268	-	-	-	28-323	-	28-803	
1-3/4	29-068	28-037	29-269	-	-	-	-	-	-	
2"	29-069	28-038	29-270	-	-	-	-	-	28-805	
2-1/4"	29-070	-	-	-	-	-	-	-	-	
2-1/2"	29-071	28-040	29-272	-	-	-	-	-	28-806	
2-3/4"	29-072	-	-	-	-	-	-	-	-	
3"	29-073	-	-	-	-	-	-	-	-	
3-1/2"	29-075	-	-	-	-	-	-	-	-	50

## 3/8" DIAMETER

	3/8-16 UNC	3/8-24 UNF	3/8-16 UNC	3/8-24 UNF	3/8-16 UNC	3/8-24 UNF	3/8-16 UNC	3/8-24 UNF	3/8-16 UNC	
1/4	-	-	-	-	-	-	28-326	28-441	-	100
3/8	-	-	-	-	-	-	28-328	28-443	-	
1/2	29-076	-	-	-	28-132	28-163	28-330	28-445	28-808	
5/8	29-077	-	-	28-090	28-133	-	28-331	28-446	28-809	
3/4	29-078	28-043	29-275	28-091	28-134	-	28-332	28-447	28-810	
7/8	29-079	-	-	-	28-135	-	-	-	-	
1"	29-080	28-045	29-276	28-092	28-136	28-164	28-334	28-448	28-811	
1-1/4	29-081	28-046	29-277	28-093	28-137	-	28-335	-	28-812	
1-1/2	29-082	28-047	29-278	28-094	-	-	28-336	-	28-813	
1-3/4	29-083	28-048	-	-	-	-	28-337(100)	-	28-814	50
2"	29-084	28-049	29-280	-	-	-	28-338(100)	-	28-815	
2-1/4	29-085	-	-	-	-	-	-	-	-	
2-1/2	29-086	-	29-282	-	-	-	-	-	28-816	
2-3/4	29-087	-	-	-	-	-	-	-	-	
3"	29-088	-	29-283	-	-	-	-	-	-	
3-1/2	29-090	-	-	-	-	-	-	-	-	
4"	29-091	-	-	-	-	-	-	-	-	
5"	29-093	-	-	-	-	-	-	-	-	



# Socket Screw Products

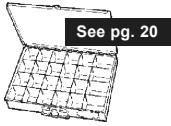

**SOCKET HEAD  
CAP SCREWS**



**FLAT HEAD  
SOCKET  
CAP SCREWS**



**BUTTON HEAD  
SOCKET  
CAP SCREWS**



**CUP POINT  
SOCKET SET  
SCREWS**



**SQUARE  
HEAD SET  
SCREWS**

LENGTH	BLACK	BLACK	BLACK	BLACK	BLACK	BLACK	PKG
--------	-------	-------	-------	-------	-------	-------	-----

## 7/16" DIAMETER

	7/16-14 UNC	7/16-20 UNF	7/16-14 UNC	7/16-20 UNF	7/16-14 UNC	7/16-20 UNF	7/16-14 UNC	7/16-20 UNF	7/16-14 UNC	
7/16	-	-	-	-	-	-	28-341	-	-	100
1/2	29-094	-	-	-	-	-	28-342	28-453	-	
5/8	-	-	-	-	-	-	-	-	-	
3/4	29-096	-	29-284	-	-	-	28-344	-	28-820	
7/8	-	-	-	-	-	-	-	-	-	
1"	29-098	28-053	29-285	-	-	-	28-346	-	28-821	
1-1/4	29-099	-	29-286	-	-	-	28-347	-	28-822	50
1-1/2	29-100	28-055	29-287	-	-	-	28-349	-	28-823	
1-3/4	29-101	-	29-288	-	-	-	-	-	-	
2"	29-102	-	29-289	-	-	-	-	-	28-825	
2-1/4	-	-	-	-	-	-	-	-	-	
2-1/2	29-104	-	-	-	-	-	-	-	-	
2-3/4	-	-	-	-	-	-	-	-	-	
3"	29-106	-	-	-	-	-	-	-	28-827	

## 1/2" DIAMETER

	1/2-13 UNC	1/2-20 UNF	1/2-13 UNC	1/2-20 UNF	1/2-13 UNC	1/2-20 UNF	1/2-13 UNC	1/2-20 UNF	1/2-13 UNC	
3/8	-	-	-	-	-	-	28-352	-	-	50
7/16	-	-	-	-	-	-	28-353	-	-	
1/2	-	-	-	-	-	-	28-354	28-454	-	
5/8	-	-	-	-	-	-	28-355	-	28-828	
3/4	29-112	-	29-290	28-095	-	-	28-356	28-456	28-829	
7/8	-	-	-	-	-	-	28-357	-	-	
1"	29-114	28-057	29-291	28-096	28-138	-	28-358	28-457	28-830	
1-1/4	29-115	28-058	29-292	28-097	28-139	-	28-359	-	28-831	
1-1/2	29-116	28-059	29-293	28-098	28-140	-	28-360	-	28-832	
1-3/4	29-117	-	29-294	-	-	-	-	-	-	
2"	29-118	28-061	29-295	28-100	28-141	-	28-362	-	28-834	
2-1/4	29-119	-	29-296	-	-	-	-	-	-	25
2-1/2	29-120	28-063	29-297	-	-	-	28-363	-	-	
2-3/4	29-121	-	-	-	-	-	-	-	-	
3"	29-122	28-064	29-298	-	-	-	28-364	-	28-838	
3-1/2	29-124	-	-	-	-	-	-	-	-	
4"	29-125	-	-	-	-	-	-	-	28-840	
4-1/2	29-126	-	-	-	-	-	-	-	-	
5"	29-127	-	-	-	-	-	-	-	28-842	
5-1/2	29-128	-	-	-	-	-	-	-	-	
6"	29-129	-	-	-	-	-	-	-	-	
6-1/2	29-130	-	-	-	-	-	-	-	-	10
7"	29-131	-	-	-	-	-	-	-	-	
8"	29-132	-	-	-	-	-	-	-	-	



# Socket Screw Products

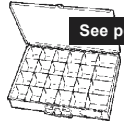

See pg. 20



**SOCKET HEAD  
CAP SCREWS**



**FLAT HEAD  
SOCKET  
CAP SCREWS**



**BUTTON HEAD  
SOCKET  
CAP SCREWS**



**CUP POINT  
SOCKET SET  
SCREWS**



**SQUARE  
HEAD SET  
SCREWS**

LENGTH	BLACK	BLACK	BLACK	BLACK	BLACK	BLACK	BLACK	BLACK	PKG
--------	-------	-------	-------	-------	-------	-------	-------	-------	-----

## 5/8" DIAMETER

	5/8-11 UNC	5/8-18 UNF	5/8-11 UNC	5/8-18 UNF	5/8-11 UNC	5/8-18 UNF	5/8-11 UNC	5/8-18 UNF	5/8-11 UNC	
5/8	-	-	-	-	-	-	28-366	28-458	-	25
3/4	-	-	-	-	-	-	28-367	-	-	
7/8	-	-	-	-	-	-	-	-	-	
1"	29-133	-	-	-	-	-	28-368	28-459	28-847	
1-1/4	29-134	-	29-299	-	-	-	28-369	-	28-848	
1-1/2	29-135	28-067	29-300	-	28-144	-	28-370	-	28-849	
1-3/4	29-136	-	29-301	-	-	-	-	-	-	
2"	29-137	28-069	29-302	-	28-145	-	28-372	-	28-851	
2-1/4	29-138	-	29-303	-	-	-	-	-	-	
2-1/2	29-139	28-070	29-304	-	-	-	28-373	-	28-853	
2-3/4	29-140	-	-	-	-	-	-	-	-	
3"	29-141	-	-	-	-	-	28-374	-	28-855	
3-1/4	29-142	-	29-305	-	-	-	-	-	-	
3-1/2	29-143	-	-	-	-	-	-	-	-	
4"	29-144	-	-	-	-	-	-	-	28-857	
4-1/2	29-145	-	-	-	-	-	-	-	-	
5"	29-146	-	-	-	-	-	-	-	-	
5-1/2	29-147	-	-	-	-	-	-	-	-	10
6"	29-148	-	-	-	-	-	-	-	28-860	
6-1/2	29-149	-	-	-	-	-	-	-	-	
7"	29-150	-	-	-	-	-	-	-	-	
8"	29-151	-	-	-	-	-	-	-	-	

## 3/4" DIAMETER

	3/4-10 UNC	3/4-16 UNF	3/4-10 UNC	3/4-16 UNF	3/4-10 UNC	3/4-16 UNF	3/4-10 UNC	3/4-16 UNF	3/4-10 UNC	
5/8	-	-	-	-	-	-	28-375	-	-	25
3/4	-	-	-	-	-	-	28-376	-	-	
7/8	-	-	-	-	-	-	-	-	-	
1"	-	-	-	-	-	-	28-377	-	28-863	
1-1/4	29-152	-	29-306	-	-	-	28-378	-	-	
1-1/2	29-153	-	29-307	-	-	-	28-379	-	28-865	
1-3/4	29-154	-	29-308	-	-	-	-	-	-	
2"	29-155	-	29-309	-	-	-	-	-	28-867	
2-1/4	-	-	-	-	-	-	-	-	-	
2-1/2	29-157	-	29-311	-	-	-	-	-	-	
2-3/4	29-158	-	-	-	-	-	-	-	-	
3"	29-159	-	29-312	-	-	-	-	-	28-871	
3-1/4	-	-	-	-	-	-	-	-	-	
3-1/2	29-161	-	-	-	-	-	-	-	-	
4"	29-162	-	-	-	-	-	-	-	-	
4-1/2	29-163	-	-	-	-	-	-	-	-	
5"	29-164	-	-	-	-	-	-	-	-	
5-1/2	29-165	-	-	-	-	-	-	-	-	10
6"	29-166	-	-	-	-	-	-	-	-	
6-1/2	29-167	-	-	-	-	-	-	-	-	



# Socket Shoulder Screws

(Stripper Bolts)

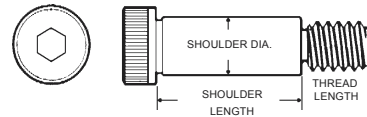

Heat treated alloy steel. 160,000 PSI min. tensile strength. Plain finish.

## 1/4" Shoulder Diameter

Thread: 10-24 dia., 3/8 long

Shoulder Length	Part Number	Pkg Qty
3/8	28-165	25
1/2	28-166	25
5/8	28-167	25
3/4	28-168	25
1"	28-169	25
1-1/4	28-170	25
1-1/2	28-171	25

Use 1/8" Hex Key Wrench

## 1/2" Shoulder Diameter

Thread: 3/8-16 dia., 5/8" long

Shoulder Length	Part Number	Pkg Qty
1/2	28-197	25
5/8	28-198	25
3/4	28-199	25
1"	28-200	25
1-1/4	28-201	25
1-1/2	28-202	25
1-3/4	28-203	25

Use 1/4" Hex Key Wrench

## 5/16" Shoulder Diameter

Thread: 1/4-20 dia., 7/16" long

Shoulder Length	Part Number	Pkg Qty
3/8	28-172	25
1/2	28-173	25
5/8	28-174	25
3/4	28-175	25
1"	28-176	25
1-1/4	28-177	25
1-1/2	28-178	25
1-3/4	28-179	25
2"	28-180	25

Use 5/32" Hex Key Wrench

## 5/8" Shoulder Diameter

Thread: 1/2-13 dia., 3/4" long

Shoulder Length	Part Number	Pkg Qty
1-1/4	28-214	25
1-1/2	28-215	25
1-3/4	28-216	25
2"	28-217	25
2-1/4	28-218	25
2-1/2	28-219	25
2-3/4	28-220	25
3"	28-221	25
3-1/2	28-223	25
4"	28-224	10
4-1/2	28-225	10

Use 5/16" Hex Key Wrench

## 3/8" Shoulder Diameter

Thread: 5/16-18 dia., 1/2" long

Shoulder Length	Part Number	Pkg Qty
3/8	28-181	25
1/2	28-182	25
5/8	28-183	25
3/4	28-184	25
1"	28-185	25
1-1/4	28-186	25
1-1/2	28-187	25
1-3/4	28-188	25
2"	28-189	25
2-1/2	28-191	25
2-3/4	28-192	25
3"	28-193	25

Use 3/16" Hex Key Wrench

## NEW LOCKING COTTERS!



SEE CATALOG PAGE 129

# 12 Pt. CounterboreScrews

(Starter Bolts or High Torque Screws)



Replaces socket head cap screws, eliminating the need for hex key wrenches. Bolt diameter is wrench size. Heat treated alloy steel. 170,000 psi min. tensile strength. Black finish.

Length	Part Number	Pkg Qty
<b>1/4-20 Diameter</b> (3/8" flange dia.)		
1/2	28-900	100
3/4	28-901	100
1	28-902	100
1-1/2	28-903	100
2	28-904	100
2-1/2	28-905	100
<b>5/16-18 Diameter</b> (15/32" flange dia.)		
1/2	28-906	100
3/4	28-907	100
1	28-908	100
1-1/2	28-909	100
2	28-910	100
2-1/2	28-911	100
<b>3/8-16 Diameter</b> (9/16" flange dia.)		
3/4	28-912	100
1	28-913	100
1-1/4	28-914	100
1-1/2	28-915	100
2	28-916	50
2-1/2	28-917	50
<b>7/16-14 Diameter</b> (21/32" flange dia.)		
1-1/4	28-918	50
1-1/2	28-919	50
2	28-920	50
2-1/2	28-921	50
<b>1/2-13 Diameter</b> (3/4" flange dia.)		
1	28-922	50
1-1/2	28-923	50
2	28-924	50
2-1/2	28-925	25
3	28-926	25
<b>5/8-11 Diameter</b> (15/16" flange dia.)		
1-1/2	28-927	25
2	28-928	25
2-1/2	28-929	25
3	28-930	25

Length is measured from under flange.

For more product information, see page 12.

# Socket Set Screws

Knurled Point



245,000 PSI min. tensile strength. Heat treated alloy steel. Close tolerance, Class 3A threads. Black finish.

6-32 Length	Part Number	Pkg Qty
1/4	28-488	100
3/8	28-490	100

8-32 Length	Part Number	Pkg Qty
1/4	28-495	100
3/8	28-497	100
1/2	28-499	100

10-24 Length	Part Number	Pkg Qty
1/4	28-501	100
3/8	28-503	100
1/2	28-505	100

1/4" Length	USS 1/4-20	SAE 1/4-28	Pkg Qty
1/4	28-507	28-541	100
3/8	28-509	28-543	100
7/16	28-510	-	100
1/2	28-511	28-545	100
3/4	28-513	-	100

5/16" Length	USS 5/16-18	SAE 5/16-24	Pkg Qty
1/4	28-514	28-548	100
5/16	28-515	28-549	100
3/8	28-516	28-550	100
7/16	28-517	-	100
1/2	28-518	28-551	100
3/4	28-520	-	100

3/8" Length	USS 3/8-16	SAE 3/8-24	Pkg Qty
3/8	28-522	-	100
1/2	28-524	28-555	100
3/4	28-526	-	100
1"	28-527	-	100

1/2" Length	USS 1/2-13	Pkg Qty
1/2	28-529	100
5/8	28-530	100
3/4	28-531	100
1"	28-532	50

Length measured overall.

# Socket Set Screws

## Half Dog Point



245,000 PSI min. tensile strength. Heat treated alloy steel. Close tolerance, Class 3A threads. Black finish.

Size	Part Number	Hex Key Size	Pkg Qty
10-24 x 3/8	28-718	3/32	100
10-24 x 1/2	28-719	3/32	100
1/4-20 x 3/8	28-722	1/8	100
1/4-20 x 1/2	28-723	1/8	100
1/4-20 x 3/4	28-725	1/8	100
5/16-18 x 5/16	28-727	5/32	100
5/16-18 x 1/2	28-729	5/32	100
3/8-16 x 1/2	28-734	3/16	100
3/8-16 x 3/4	28-736	3/16	100
3/8-16 x 1"	28-737	3/16	100

Length measured overall. Other sizes available upon special request (subject to minimum packaging).



SEE PAGE 327.

# Socket Screw Assortments & Kits



**FLAT SOCKET HEAD CAP SCREW ASSORTMENT**  
24 SIZES, 1/4" - 1/2" DIA.  
COARSE THRD., UP TO 2-1/2"  
IN A LARGE STEEL DRAWER.  
**PART NO. 16-0524**



**SOCKET HEAD CAP SCREW ASSORTMENT**  
24 SIZES, 1/4" - 1/2" DIA.  
COARSE THRD., UP TO 2-1/2"  
IN A LARGE STEEL DRAWER  
**PART NO. 16-0424**



**SOCKET SET SCREW ASSORTMENT - CUP POINT**  
24 SIZES, 6/32 - 5/8" DIA. IN A  
LARGE STEEL DRAWER.  
**PART NO. 16-0624**

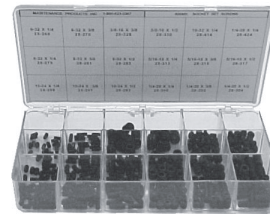

**SOCKET SET SCREW MAINTENANCE KIT - CUP POINT**  
18 SIZES, 6/32 - 3/8" DIA.  
COARSE & FINE THREADS, IN A  
CLEAR POLYSTYRENE BOX.  
**PART NO. 506MK**

## Hex Key Wrench Sizes

TYPE OF SCREW	SCREW DIAMETER															
	No.4	No.5	No.6	No.8	No.10	1/4	5/16	3/8	7/16	1/2	5/8	3/4	7/8	1"	1-1/4	1-1/2
SOCKET HEAD CAP SCREWS	3/32	3/32	7/64	9/64	5/32	3/16	1/4	5/16	3/8	3/8	1/2	5/8	3/4	3/4	7/8	1"
FLAT HEAD SOCKET C/S	1/16	5/64	5/64	3/32	1/8	5/32	3/16	3/16	1/4	5/16	3/8	1/2	-	-	-	-
BUTTON HEAD SOCKET C/S	1/16	-	5/64	3/32	1/8	5/32	3/16	3/16	-	5/16	3/8	-	-	-	-	-
SOCKET SET SCREWS	.050	1/16	1/16	5/64	3/32	1/8	5/32	5/32	7/32	1/4	5/16	3/8	1/2	9/16	-	-
SOCKETSHOULDER SCREWS	-	-	-	-	-	1/8	5/32	5/32	-	1/4	5/16	3/8	-	-	-	-

# Carriage, Elevator and Plow Bolts

## GRADE 2 CARRIAGE BOLTS

The square neck keeps screw from turning when you tighten or loosen the nut. Use for wood-to-wood and wood-to-metal fastening. Length is measured from base of head.

*Thread length: Up to 7/16" dia. fully threaded; over 6" long are 2 x dia. +1/4".*

Min. Tensile Strength: 60,000 p.s.i.  
Finish: Blue chromate dipped (up to 1" dia, 6" lg.)  
Grade mark: none

Material: AISI 1006/1050 low carbon steel  
Core Hardness: Rockwell B70-100  
Meets ANSI/ASME B18.5



## GRADE 5 CARRIAGE BOLTS

Same design advantages as grade 2 carriage bolt but with significantly greater load carrying capacity. Use where strength and durability is a concern. Use for metal-to-metal and wood-to-metal fastening. Length is measured from base of head. *Thread length: Up to 7/16 dia., 2 x dia. +1/4": 1/2" dia. and over are fully threaded.* Heat treatment: quenched and tempered to 800°F.

Min. Tensile Strength: 120,000 p.s.i.  
Finish: Unplated (black and oiled)  
Grade mark: 3 radial lines

Material: AISI 1030/1050 medium carbon steel  
Core Hardness: Rockwell C25-34  
Meets ANSI/ASME B18.5, SAE J429



## ELEVATOR BOLTS (NO. 1 NORWAY HEAD)

Also known as belt bolts, elevator bolts have a wide, countersunk flat head with a shallow bearing surface. Primarily used on conveyors and elevators, but used anywhere head clearance must be kept to a minimum. Length is measured from top of head. *Thread length is 2 x dia. +1/4".*

Min. Tensile Strength: 54,000 p.s.i.  
Finish: Zinc plated  
Grade mark: none

Material: AISI 1006/1050 low carbon steel  
Core Hardness: Rockwell B70-100  
Meets IFI standards.



## GRADE 5 PLOW BOLTS (NO. 3 FLAT HEAD)

Also known as scraper or blade bolts, these square shank bolts are commonly used on scrapers, dozers, road graders, snow plows and many farm implements. Length is measured from top of head. *Thread length is 2 x dia. +1/4".* Heat treatment: quenched and tempered to 800°F.

Min. Tensile Strength: 120,000 p.s.i.  
Finish: Unplated  
Grade mark: 3 radial lines

Material: AISI 1030/1050 med. carbon steel  
Core Hardness: Rockwell C25-34  
Meets ANSI B18.9, SAE J429



## GRADE 8 PLOW BOLTS (NO. 3 DOME HEAD)

Similar to a grade 5 plow bolt, but features a dome head providing extra metal at the wearing surface. Grade 8 alloy steel higher tensile strength. Length is measured from top of head. *Thread length is 2 x dia. +1/4".* Heat treatment: quenched and tempered to 800°F.

Min. Tensile Strength: 150,000 p.s.i.  
Finish: Unplated  
Grade mark: 6 radial lines

Material: AISI 4037/4042 alloy steel  
Core Hardness: Rockwell C33-39  
Meets ANSI B18.9, SAE J429



# Carriage & Elevator Bolts

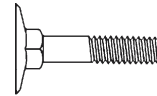
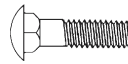

**GRADE 2  
CARRIAGE BOLTS**

**GRADE 5  
CARRIAGE BOLTS**

**ELEVATOR BOLTS  
NO.1 NORWAY HEAD**

LENGTH	BRIGHT ZINC	BLACK	BRIGHT ZINC	PKG QTY
<b>10-24 COARSE THREAD (NC)</b>				
3/4	NC002-5	-	-	100
1"	NC004-5	-	-	
1-1/4	NC005-5	-	-	
1-1/2	NC006-5	-	-	
1-3/4	NC007-5	-	-	
2"	NC008-5	-	-	
<b>1/4-20 COARSE THREAD (NC)</b>				
3/4	NC102-5	32-274	32-200†	100
1"	NC104-5	32-275	32-201†	
1-1/4	NC105-5	32-276	32-202†	
1-1/2	NC106-5	32-277	32-203†	
1-3/4	NC107-5	-	32-204†	
2"	NC108-5	32-278	32-205†	
2-1/4	NC109-5	-	-	
2-1/2	NC110-5	-	-	
2-3/4	NC111-5	-	-	50
3"	NC112-5	-	-	
3-1/2	NC114-5	-	-	
4"	NC116-5	-	-	
4-1/2	NC118-5	-	-	
5"	NC120-5	-	-	
5-1/2	NC121-5	-	-	
6"	NC122-5	-	-	
7"	NC124-5	-	-	
8"	NC126-5	-	-	
<b>5/16-18 COARSE THREAD (NC)</b>				
3/4	NC202-5	32-279	-	100
1"	NC204-5	32-280	32-207‡	
1-1/4	NC205-5	32-281	32-208‡	
1-1/2	NC206-5	32-282	32-209‡	
1-3/4	NC207-5	32-283	32-210‡	
2"	NC208-5	32-284	32-211‡	
2-1/4	NC209-5	-	32-212‡	
2-1/2	NC210-5	32-285	-	
2-3/4	NC211-5	-	-	
3"	NC212-5	32-286	-	
3-1/2	NC214-5	-	-	50
4"	NC216-5	-	-	
4-1/2	NC218-5	-	-	
5"	NC220-5	-	-	
5-1/2	NC221-5	-	-	
6"	NC222-5	-	-	
7"	NC224-5	-	-	
8"	NC226-5	-	-	

† Head diameter is 31/32". ‡ Head diameter is 1-3/16".

# Carriage, Elevator & Plow Bolts

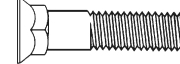
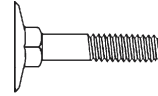
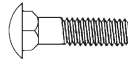

**GRADE 2  
CARRIAGE BOLTS**

**GRADE 5  
CARRIAGE BOLTS**

**ELEVATOR BOLTS  
NO.1 NORWAY HEAD**

**GRADE 5 PLOW BOLTS  
NO.3 FLAT HEAD**

LENGTH	BRIGHT ZINC	BLACK	BRIGHT ZINC	BLACK	PKG QTY	
<b>3/8-16 COARSE THREAD (NC)</b>						
3/4"	NC302-5	32-287	-	-	100	
1"	NC304-5	32-288	32-214†	18-800		
1-1/4"	NC305-5	32-289	32-215†	18-801		
1-1/2"	NC306-5	32-290	32-216†	18-802		
1-3/4"	NC307-5	32-291	32-217†	18-803 (50)		
2"	NC308-5	32-292	32-218†	18-804 (50)		
2-1/4"	NC309-5	-	-	-		
2-1/2"	NC310-5	32-293	32-219†	18-805		50
2-3/4"	NC311-5	-	-	18-806		
3"	NC312-5	32-294	-	-		
3-1/2"	NC314-5	32-295	-	-		
4"	NC316-5	32-296	-	-		
4-1/2"	NC318-5	-	-	-		
5"	NC320-5	-	-	-		
5-1/2"	NC321-5	-	-	-		
6"	NC322-5	-	-	-		
7"	NC324-5	-	-	-		
8"	NC326-5	-	-	-		
<b>7/16-14 COARSE THREAD (NC)</b>						
3/4"	-	-	-	-	50	
1"	NC404-5	-	-	-		
1-1/4"	NC405-5	-	-	18-807		
1-1/2"	NC406-5	32-397	-	18-808		
1-3/4"	NC407-5	-	-	18-809		
2"	NC408-5	32-298	-	18-810		
2-1/4"	NC409-5	-	-	18-811		
2-1/2"	NC410-5	32-299	-	18-812		
2-3/4"	-	-	-	18-813		
3"	NC412-5	-	-	18-814		
3-1/2"	-	-	-	18-815	25	
4"	NC416-5	-	-	18-816		
4-1/2"	-	-	-	-		
5"	NC420-5	-	-	-		
5-1/2"	-	-	-	-		
6"	NC422-5	-	-	-		
7"	-	-	-	-		
8"	-	-	-	-		

† Head diameter is 1-5/16".



# Carriage, Shaker Screen & Plow Bolts

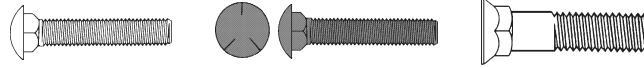

**GRADE 2 CARRIAGE BOLTS**      **GRADE 5 SHAKER SCREEN BOLTS<sup>†</sup>**      **GRADE 5 PLOW BOLTS NO.3 FLAT HEAD**

LENGTH	BRIGHT ZINC	BLACK	BLACK	PKG QTY	
<b>1/2-13 COARSE THREAD (NC)</b>					
1-1/4	-	-	18-817	50	
1-1/2	NC506-5	32-300	18-818		
1-3/4	NC507-5	-	18-819		
2"	NC508-5	32-301	18-820		
2-1/4	NC509-5	-	18-821		
2-1/2	NC510-5	32-302	18-822		
2-3/4	NC511-5	-	18-823 <sup>(25)</sup>		
3"	NC512-5	32-303	18-824 <sup>(25)</sup>		
3-1/2	NC514-5	32-304	18-825		25
4"	NC516-5	32-305	18-826		
4-1/2	NC518-5	32-306	-		
5"	NC520-5	32-307	-		
6"	NC522-5	32-308	-		
7"	NC524-5	32-309	-		
8"	NC526-5	-	-		

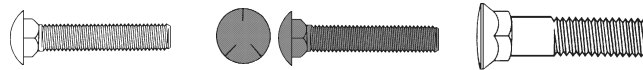

**GRADE 2 CARRIAGE BOLTS**      **GRADE 5 SHAKER SCREEN BOLTS<sup>†</sup>**      **GRADE 8 PLOW BOLTS (NO.3 DOME HD)**

LENGTH	BRIGHT ZINC	BLACK	BLACK	PKG QTY
<b>5/8-11 COARSE THREAD (NC)</b>				
1-1/2	NC706-5	-	-	25
2"	NC708-5	32-311	18-900	
2-1/4	-	-	18-901	
2-1/2	NC710-5	32-312	18-902	
2-3/4	-	-	18-903	
3"	NC712-5	32-313	18-904	
3-1/2	NC714-5	32-314	18-905	
4"	NC716-5	32-315	18-906	
4-1/2	NC718-5	32-316	18-907	
5"	NC720-5	32-317	18-908	
5-1/2	NC721-5	-	18-909	
6"	NC722-5	32-318	18-910	
7"	NC724-5	-	-	
8"	NC726-5	-	-	

<sup>†</sup>Fully threaded carriage bolts.



# Carriage, Shaker Screen & Plow Bolts

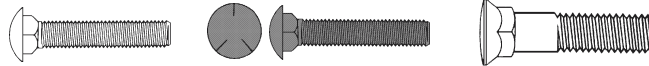

**GRADE 2  
CARRIAGE BOLTS**

**GRADE 5 SHAKER  
SCREEN BOLTS\***

**GRADE 8 PLOW BOLTS  
NO.3 DOME HEAD**

LENGTH	BRIGHT ZINC	BLACK	BLACK	PKG QTY
--------	-------------	-------	-------	---------

## 3/4-10 COARSE THREAD (NC)

2"	-	-	18-911 (25)	20
2-1/2	-	-	18-913 (25)	
2-3/4	-	-	18-914 (25)	
3"	NC812-5	32-319	18-915 (25)	
3-1/2	NC814-5	32-320	18-916 (25)	
4"	NC816-5	32-321	18-917 (25)	
4-1/2	NC818-5	32-322	18-918 (25)	
5"	NC820-5	32-323	18-919 (25)	
5-1/2	-	-	-	
6"	NC822-5	32-324	-	
7"	NC824-5	-	-	
8"	NC826-5	-	-	

## 7/8-9 COARSE THREAD (NC)

2-1/2	-	-	18-922	25
3"	-	-	18-924	
3-1/2	-	-	18-925	
4"	-	-	18-926	
5"	-	-	18-928	15

## 1" - 8 COARSE THREAD (NC)

3"	-	-	18-932	10
3-1/2	-	-	18-933	
4"	-	-	18-934	
4-1/2	-	-	18-935	
5"	-	-	18-936	

\*Fully threaded carriage bolts.

## WRIGHT TOOL COMPANY

70 years of performance and innovation...

Wright Tools are fully guaranteed  
and they're in stock at MPI.  
Call us for a free catalog!

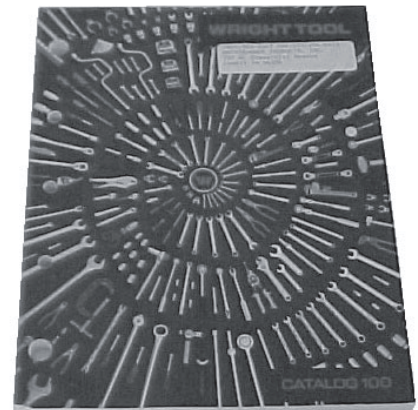

# Cylinder Head and Manifold Studs

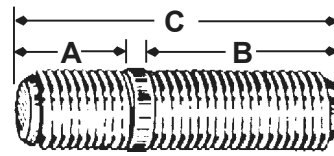

Grade 5 medium carbon steel. Heat-treated. Plain finish.

Part No.	"A" Dia. x Length	"B" Dia. x Length	"C" Overall Length	Pkg. Qty.
9-251	1/4-28 NF x 1/2	1/4-20 NC x 1/2	1-1/4	10
9-252	1/4-28 NF x 3/4	1/4-20 NC x 1/2	1-1/2	10
9-253	1/4-28 NF x 1"	1/4-20 NC x 1/2	2"	10
9-254	5/16-24 NF x 1/2	5/16-18 NC x 3/8	1"	10
9-256	5/16-24 NF x 5/8	5/16-18 NC x 3/4	1-1/2	10
9-261	5/16-18 NC x 7/8	5/16-18 NC x 7/16	1-1/2	10
9-257	5/16-24 NF x 7/8	5/16-18 NC x 9/16	1-3/4	10
9-258	5/16-24 NF x 1"	5/16-18 NC x 3/4	2"	10
9-262	5/16-18 NC x 1"	5/16-18 NC x 7/16	2"	10
9-260	5/16-24 NF x 1-5/8	5/16-18 NC x 1/2	2-1/2	10
9-263	5/16-24 NF x 1-1/2	5/16-18 NC x 5/8	3"	10
9-265	3/8-24 NF x 3/4	3/8-16 NC x 1/2	1-1/2	10
9-266	3/8-24 NF x 3/4	3/8-16 NC x 1/2	3/4	10
9-267	3/8-24 NF x 3/4	7/16-14 NC x 7/8	1-7/8	10
9-268	3/8-24 NF x 1"	3/8-16 NC x 5/8	2"	10
9-269	3/8-16 NC x 1-1/8	3/8-16 NC x 5/8	2"	10
9-271	3/8-16 NC x 1-1/2 •	3/8-16 NC x 7/16	2-7/32	10
9-272	3/8-24 NF x 1"	3/8-16 NC x 3/4	2-3/4	10
9-264	3/8-16 NC x 5/8	3/8-16 NC x 2"	3"	10
9-273	3/8-24 NF x 2"	3/8-16 NC x 5/8	3"	10
9-274	3/8-16 NC x 1-5/8	3/8-16 NC x 7/16	3-1/4	10
9-275	3/8-16 NC x 1-5/8 •	3/8-16 NC x 7/16	3-5/16	10
9-276	3/8-24 NF x 1"	3/8-16 NC x 3/4	3-3/4	10
9-278	3/8-24 NF x 1-7/8	3/8-16 NC x 1/2	4"	10
9-279	7/16-20 NF x 3/4	7/16-14 NC x 1/2	1-1/2	10
9-281	7/16-20 NF x 3/4	7/16-14 NC x 9/16	1-3/4	10
9-282	7/16-20 NF x 7/8	7/16-14 NC x 3/4	2"	10
9-283	7/16-14 NC x 15/16	7/16-14 NC x 3/4	2"	10
9-285	7/16-20 NF x 3/4	7/16-14 NC x 3/4	2-1/4	10
9-286	7/16-20 NF x 7/8	7/16-14 NC x 3/4	2-1/2	10
9-287	7/16-14 NC x 1-1/4	7/16-14 NC x 3/4	2-1/2	10
9-289	7/16-20 NF x 1-13/16	7/16-14 NC x 3/4	3"	10
9-290	1/2-20 NF x 5/8	1/2-13 NC x 9/16	1-1/2	10
9-292	1/2-20 NF x 5/16	1/2-13 NC x 5/8	2"	10
9-293	1/2-20 NF x 1-1/8	1/2-13 NC x 3/4	2-1/4	10
9-298	9/16-18 NF x 1"	9/16-12 NC x 3/4	2-1/2	10
9-299	9/16-18 NF x 1-1/4	9/16-12 NC x 1"	3"	10
9-300	5/8-18 NF x 1"	5/8-11 NC x 3/4	2-1/2	10
9-301	5/8-11 NC x 1-1/2	5/8-11 NC x 13/16	2-5/8	10
9-302	5/8-18 NF x 1-1/4	5/8-11 NC x 1"	3"	10
9-303	5/8-18 NF x 1-1/2	5/8-11 NC x 1-1/4	3-1/2	10

• Dog point one end NC = national coarse thread. NF = national fine thread.

**SAVE WHEN YOU BUY IN QUANTITY!**

# Truck Wheel Studs & Nuts

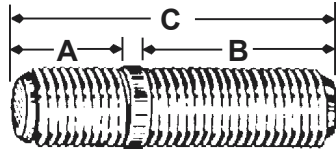

## Wheel Studs

Grade 8 alloy steel. All coarse thread. Zinc finish.  
Pkg. 25 each

Part No.	Diam.	A	B	C
03-300	5/8-11	1"	1-1/2"	2-3/4"
03-301	3/4-10	1-1/16"	1-11/16"	2-13/16"

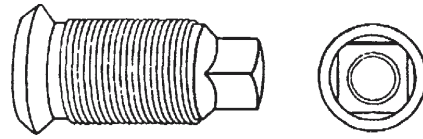

## Inner Cap Nuts

Budd style wheel nut. All fine thread. Zinc finish

Part No.	Inner	Outer	Budd No.	Pkg
03-298	3/4-16	1-1/8" R.H.	10708	10
03-294	3/4-16	1-1/8" L.H.	10709	10



Grade 2H



Washer Faced

## Wheel Nuts

(Gr. 2H Heavy Hex Nuts)

Grade 2H heat treated steel. All coarse thread.  
Plain finish.

Part No.	Size	W.A.F.	Pkg
03-027	5/8-11	1-1/16"	50
03-028	3/4-10	1-1/4"	25

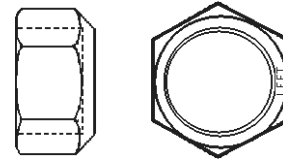

## Outer Cap Nuts

Budd style wheel nut. Fine thread. Zinc finish.

Part No.	Size	Budd No.	Pkg
03-291	1-1/8 R.H.	37891	10
03-292	1-1/8 L.H.	37892	10

## BRAKE & WHEEL PARTS

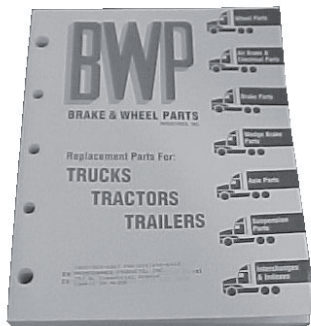

Specializing in parts for  
the trucking industry.  
Call MPI for a free catalog!

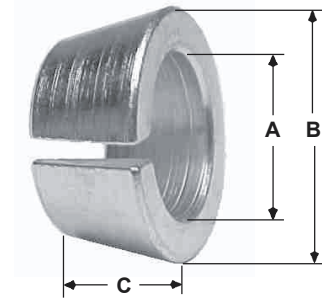

## Drive Flange Wedges

Part No.	A	B	C	Pkg
03-306	7/16"	3/4"	3/8"	25
03-307	1/2"	3/4"	5/16"	25
03-308	1/2"	13/16"	3/8"	25
03-309	5/8"	1"	7/16"	25

# Hex Lag Screws

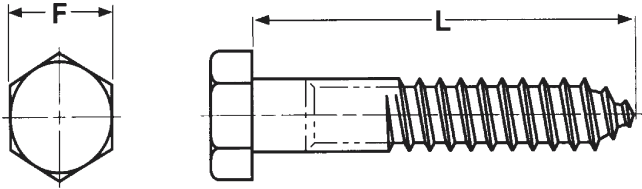

For use in wood fastening in noncorrosive environments. Made from AISI 1006/1022 low carbon steel. Thread length: half of screw length + 1/2" or 5", whichever is shorter. Zinc finish†.



Dia. x Length (L)	Wrench Size (F)	Part No.	Pkg Qty
1/4 x 1"	7/16"	18-700	100
1/4 x 1-1/4"	7/16"	18-701	100
1/4 x 1-1/2"	7/16"	18-702	100
1/4 x 2"	7/16"	18-703	100
1/4 x 2-1/2"	7/16"	18-704	100
1/4 x 3"	7/16"	18-705	50
1/4 x 3-1/2"	7/16"	18-706	50
1/4 x 4"	7/16"	18-707	50
1/4 x 4-1/2"	7/16"	18-708	50
1/4 x 5"	7/16"	18-709	25
1/4 x 6"	7/16"	18-710	25
5/16 x 1"	1/2"	18-711	100
5/16 x 1-1/4"	1/2"	18-712	100
5/16 x 1-1/2"	1/2"	18-713	100
5/16 x 2"	1/2"	18-714	100
5/16 x 2-1/2"	1/2"	18-715	50
5/16 x 3"	1/2"	18-716	50
5/16 x 3-1/2"	1/2"	18-717	50
5/16 x 4"	1/2"	18-718	50
5/16 x 4-1/2"	1/2"	18-719	50
5/16 x 5"	1/2"	18-720	25
5/16 x 6"	1/2"	18-721	25
3/8 x 1"	9/16"	18-722	100
3/8 x 1-1/4"	9/16"	18-723	100
3/8 x 1-1/2"	9/16"	18-724	100
3/8 x 2"	9/16"	18-725	100
3/8 x 2-1/2"	9/16"	18-726	50
3/8 x 3"	9/16"	18-727	50
3/8 x 3-1/2"	9/16"	18-728	25
3/8 x 4"	9/16"	18-729	25
3/8 x 4-1/2"	9/16"	18-730	25
3/8 x 5"	9/16"	18-731	25
3/8 x 6"	9/16"	18-732	25
3/8 x 8"	9/16"	18-734	25
1/2 x 2"	3/4"	18-736	50
1/2 x 3"	3/4"	18-738	25
1/2 x 4"	3/4"	18-740	25
1/2 x 5"	3/4"	18-742	25
1/2 x 6"	3/4"	18-744	25
1/2 x 8"	3/4"	18-746	25

†Hot dipped galvanized and stainless steel available on request, subject to minimum packaging.

# U-Bolts

with Hex Nuts

All coarse thread (NC).  
Low carbon steel.  
Zinc plated.

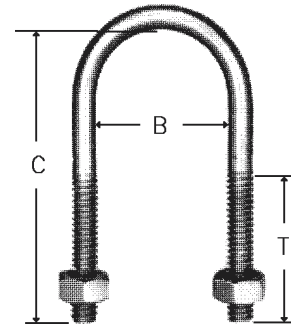

PKG QTY: 10 EACH

Part No.	(B) Between Legs	(C) Inside Length	(T) Thread Length	For Pipe Size
----------	------------------	-------------------	-------------------	---------------

## 1/4-20 DIAMETER

18-654	9/16	1-1/4	3/4	1/4
18-655	3/4	1-1/4	3/4	3/8
18-656	1"	1-3/4	1"	1/2
18-657	1-1/8	2"	1"	3/4
18-658	1-1/2	2-3/4	1-3/8	1"
18-659	1-3/4	3"	1-3/8	1-1/4
18-660	2"	3-1/4	1-3/8	1-1/2

## 5/16-18 DIAMETER

18-661	1"	2-3/16	1-3/8	1/2
18-662	1-1/8	2-3/16	1"	3/4
18-663	1-1/2	2-3/16	1"	1"
18-664	1-3/4	2-11/16	1-1/8	1-1/4
18-665	2"	2-11/16	1"	1-1/2
18-666	2-1/2	3-3/16	1"	2"

## 3/8-16 DIAMETER

18-667	1"	2-1/4	1-1/4	1/2
18-668	1-1/8	2-1/4	1-1/4	3/4
18-669	1-1/2	2-1/2	1-1/4	1"
18-670	1-3/4	2-3/4	1-1/4	1-1/4
18-671	2"	2-5/8	1-1/4	1-1/2
18-672	2-1/2	3-1/8	1-1/4	2"
18-673	3"	3-5/8	1-1/4	2-1/2
18-674	3-1/2	4-1/8	1-1/4	3"

## 1/2-13 DIAMETER

18-675	3"	4-1/2	1-5/8	2-1/2
18-676	3-1/2	5"	1-1/2	3"
18-677	4"	5-1/2	1-1/2	3-1/2
18-678	4-1/2	6"	1-1/2	4"
18-679	6-3/4	8-3/8	2"	6"

The cardiologist's diet:  
If it tastes good,  
spit it out.

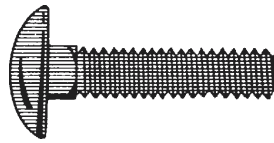

### Round Head Bumper Bolts

Low carbon steel. Stainless steel capped heads.  
All coarse thread (NC).

Part No.	Size	Pkg
9-540	1/4-20 x 3/4	25
9-541	5/16-18 x 1"	25
9-542	5/16-18 x 1-1/2	25
9-543	3/8-16 x 1"	25
9-544	3/8-16 x 1-1/4	25
9-545	3/8-16 x 1-1/2	25
9-546	7/16-14 x 1"	25
9-547	7/16-14 x 1-1/4	25
9-548	7/16-14 x 1-1/2	25
9-549	7/16-14 x 1-3/4	25
9-550	7/16-14 x 2"	25
9-551	7/16-14 x 2-1/4	25
9-539	1/2-13 x 1-1/4	25
9-553	1/2-13 x 1-1/2	25
9-555	1/2-13 x 2"	25

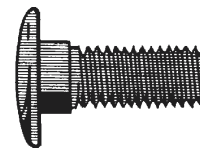

### Flat Head Bumper Bolts

Low carbon steel. Stainless steel capped heads.  
All coarse thread (NC).

Part No.	Size	Pkg
9-556	3/8-16 x 1"	25
9-557	7/16-14 x 1"	25
9-558	7/16-14 x 1-3/8	25
9-559	1/2-13 x 1-3/8	25

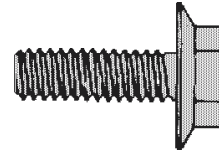

### Spinlock Body Bolts

Locking serrations under head. Black oxide finish.  
All coarse thread (NC).

Part No.	Size*	Pkg
9-567	1/4-20 x 5/8	100
9-569	3/8-16 x 1"	50

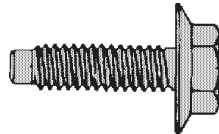

### Spinlock Body Bolts

Locking serrations under head. Dog point aligns bolt with hole. Black oxide finish. All coarse thread (NC).

Part No.	Size*	Pkg
9-561	5/16-18 x 3/4	100
9-562	5/16-18 x 1"	50
9-563	5/16-18 x 1-1/4	50

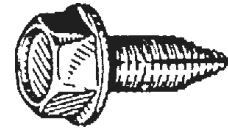

### Hex Washer Head Body Bolts

Cone point. Black oxide finish. All coarse thread (NC).

Part No.	Size*	Pkg
9-573	5/16-18 x 13/16	50
9-574	5/16-18 x 1"	50
9-575	5/16-18 x 1-1/4	50
9-576	5/16-18 x 1-1/2	50

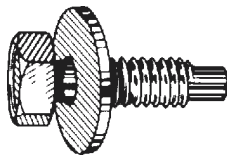

### Sems® Body Bolt

Hex head with loose flat washer. Dog point.  
Black oxide finish. All coarse thread (NC).

Part No.	Size*	Pkg
9-564	1/4-20 x 7/8	50
9-565	1/4-20 x 1"	50
9-566	5/16-18 x 7/8	50

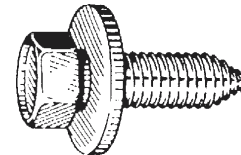

### Hex Washer Head Sems® Body Bolt

Cone point. Loose flat washer. Black oxide finish.  
All coarse thread (NC).

Part No.	Size*	Pkg
9-577	5/16-18 x 1"	25
9-578	3/8-16 x 1"	25
9-579	3/8-16 x 1-1/2	25

\*Lengths measured from under flange/washer.

# License Plate Fasteners

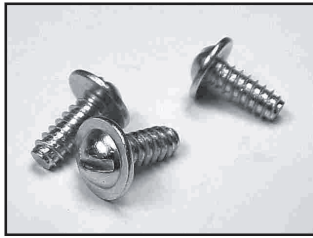

**TYPE B STEEL LICENSE SCREW**  
14 x 5/8" round slotted screws have blunt point. Use with any nylon license nut listed below. Zinc plated. Pkg: 100 each. **Part no. 9-588**

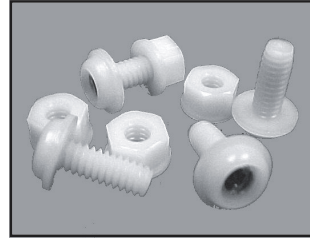

**NYLON LICENSE SCREW W/NYLON LOCKNUT**  
1/4-20 x 5/8" slotted nylon license screw is reinforced with *plated steel pin* for extra strength. Solid nylon locknut is washer faced. Corrosion resistant. Pkg: 100 sets. **Part no. 9-590**



**TYPE "A" STEEL LICENSE SCREW**  
14 x 3/4" hex head slotted tapping screws. Use with any nylon license nut listed below. Zinc plated. Pkg: 100 each. **Part no. 9-589**



**UNIVERSAL LICENSE SCREWS**  
1/4-20 x 9/16" slotted machine screws. Use with spin-lock nuts (below) or any 1/4" hex nut. Zinc plated. Pkg: 100 each. **Part no. 9-586**



**TYPE "F" STEEL LICENSE SCREW**  
Type F thread cutting 1/4-20 x 5/8" slotted screw. Use with any nylon license nut listed below. Zinc plated. Pkg: 100 each. **Part no. 24-353**



**1/4-20 SPINLOCK NUTS**  
Self-locking nut with serrated washer face. Use with 9-586 (above). Zinc plated. Pkg: 100 each. **Part no. 03-211**

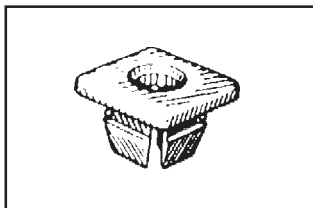

**UNIVERSAL NYLON LICENSE NUT**  
For 1/4-20 or #14 screw size. Fits 3/8" square hole. Corrosion resistant. Pkg: 50 each. **Part no. 9-580**



**STEEL LICENSE SCREW W/NUT**  
1/4-20 x 9/16" steel slotted machine screws with steel hex nuts. Zinc plated. Pkg: 100 sets. **Part no. 9-583**

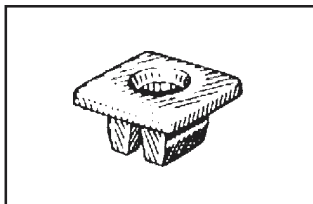

**ORIGINAL GM NYLON LICENSE NUT**  
For 1/4-20 or #14 screw size. Corrosion resistant. *GM no. 1196781*. Pkg: 50 each. **Part no. 9-582**

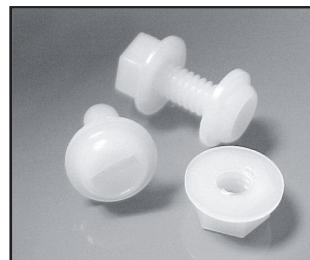

**ALL NYLON LICENSE SCREW W/FLANGE NUT**  
1/4-20 x 9/16" nylon slotted screws with nylon flange nuts. Corrosion resistant. Pkg: 100 sets. **Part no. 9-587**

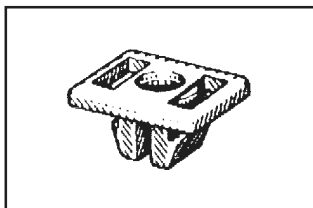

**ORIGINAL FORD NYLON LICENSE NUT**  
For 1/4-20 or #14 screw size. Corrosion resistant. *Ford no. 380707-S*. Pkg: 50 each. **Part no. 9-581**



# Drop Forged Eye Bolts

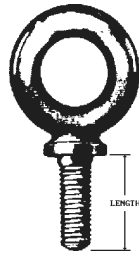

Shoulder pattern type.  
All coarse thread (NC). Plain finish.

Part No.	Thread Size	Shank Length	Eye I.D.	Eye O.D.	Pkg Qty
18-591	1/4-20	1"	3/4	1-1/4	12
18-592	5/16-18	1-1/8	7/8	1-1/2	12
18-593	3/8-16	1-1/4	1"	1-21/32	12
18-594	7/16-14	1-3/8	1-3/32	1-27/32	6
18-595	1/2-13	1-1/2	1-3/16	2-1/16	6
18-596	9/16-12	1-5/8	1-9/32	2-9/32	6
18-597	5/8-11	1-3/4	1-3/8	2-1/2	6
18-598	3/4-10	2"	1-1/2	2-13/16	6
18-599	7/8-9	2-1/4	1-11/16	3-1/4	1
18-600	1"-8	2-1/2	1-13/16	3-9/16	1
18-601	1-1/8-7	2-3/4	2"	4"	1
18-602	1-1/4-7	3"	2-3/16	4-7/16	1
18-603	1-1/2-6	3-1/2	2-1/2	5-3/16	1

*Warning: Angular lifts should be avoided whenever possible.*

## Forged Eye Bolt Recommended Load Limits

Maximum working load limit (lbs.)<sup>†</sup>

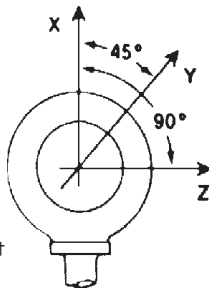

Thread Size	Trade Size	Straight Pull "X"	45° Pull "Y"	90° Pull <sup>‡</sup> "Z"
1/4-20	21	500	125	-
5/16-18	22	900	225	-
3/8-16	23	1400	350	-
7/16-14	24	2000	500	-
1/2-13	25	2600	650	-
9/16-12	26	3000	750	-
5/8-11	27	4000	1000	-
3/4-10	28	6000	1500	-
7/8-9	29	7000	1750	-
1-8	30	9000	2250	-
1-1/8-7	31	10000	2500	-
1-1/4-7	32	15000	3750	-
1-1/2-6	34	19600	4900	-

<sup>†</sup> Never exceed maximum working load limits.

<sup>‡</sup> Not recommended by the manufacturer. ALWAYS AVOID 90° PULLS.

# Formed Wire Eyebolts

with Hex Nuts

General purpose, closed-eye type eyebolts are used for hanging fixtures and anchoring light loads. Bent wire is formed from low carbon steel, machine threaded. All coarse thread (NC). Zinc finish.

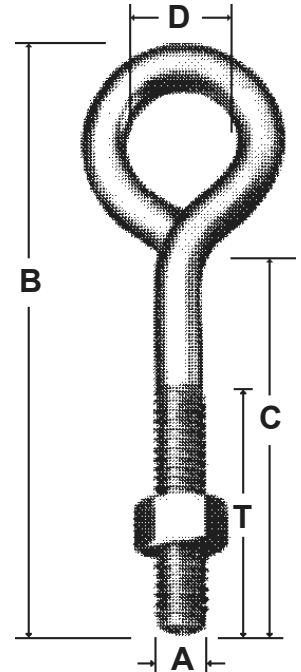

PKG: 10 EACH

Part No.	(A) Thread Diam.	(B) O.A. Length	(C) Shank Length	(T) Thread Length	(D) Eye I.D.
18-500	8-32	1-5/8	1-1/8	1"	1/4
18-501	10-24	1-1/2	1"	7/8	5/16
18-502	10-24	2"	1-5/16	1-1/4	5/16
18-503	10-24	2-1/2	1-5/8	1-1/2	1/2
18-504	10-24	3"	2-1/4	2"	1/2
18-505	12-24	2-1/8	1-1/2	1-3/8	5/16
18-506	1/4-20	2"	1-1/4	1"	3/8
18-507	1/4-20	2-5/8	1-7/8	1-1/2	3/8
18-508	1/4-20	3"	2-1/4	2"	3/8
18-509	1/4-20	4"	3"	2"	9/16
18-510	1/4-20	5"	4"	2-7/8	9/16
18-512	1/4-20	6"	5"	2-7/8	9/16
18-514	1/4-20	8"	6-3/4	2-7/8	9/16
18-515	5/16-18	3-1/4	2-1/4	1-7/8	1/2
18-516	5/16-18	4"	2-5/8	2"	3/4
18-517	5/16-18	5"	3-5/8	2-7/8	3/4
18-518	5/16-18	6"	4-5/8	2-7/8	3/4
18-519	5/16-18	8"	6-5/8	3-7/8	3/4
18-520	3/8-16	4"	2-1/2	2-1/8	5/8
18-521	3/8-16	5"	3-1/4	2-7/8	1"
18-522	3/8-16	6"	4-1/4	3-7/8	1"
18-523	3/8-16	8"	6-1/4	3-7/8	1"
18-524	3/8-16	10"	8-1/4	3-3/4	1"
18-525	3/8-16	12"	10-1/4	3-3/4	1
18-526	7/16-14	6"	3-3/4	3-1/4	1-1/8
18-527	7/16-14	8"	5-3/4	3-7/8	1-1/8
18-528	1/2-13	6"	4"	2-1/2	1-1/4
18-529	1/2-13	8"	5-3/4	3-7/8	1-1/4
18-530	1/2-13	10"	7-3/4	3-7/8	1-1/4
18-531	1/2-13	12"	9-3/4	3-7/8	1-1/4

# Screw Hooks

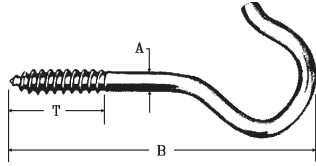

Low carbon steel. Zinc plated.

Part No.	(A) Wire Diam.	Approx. Diam.	(B) Overall Length	(T) Thread Length	Pkg Qty
18-554	.080	#2	1-1/4	1/2	100
18-555	.105	#5	1-5/8	1/2	100
18-556	.135	#8	2"	5/8	100
18-557	.162	#10	2-1/2	7/8	100
18-558	.192	#12	3-3/8	1-1/8	100
18-559	.225	#16	3-7/8	1-1/4	50
18-560	.243	#18	4-1/8	1-1/2	50
18-561	.263	#20	4-1/2	1-3/8	50
18-562	.306	#3/8	5"	1-1/2	50

# Peg Board Hooks



## 1/8" DIAMETER STRAIGHT HOOKS

Fits 1/8" and 1/4" perforated board. Zinc finish.

Part No.	Usable Length	No. Hooks Per Pkg	Order Unit
9-235	2"	4 ea.	1 pkg
9-236	4"	3 ea.	1 pkg
9-237	6"	3 ea.	1 pkg
9-238	8"	3 ea.	1 pkg



## 1/4" DIAMETER STRAIGHT HOOKS

Fits standard 1/4" perforated board. Zinc finish.

Part No.	Usable Length	Pkg Qty
9-306	2-1/2"	50
9-307	3-1/4"	50
9-308	5-1/4"	50
9-309	8-1/4"	10

# Cup Hooks

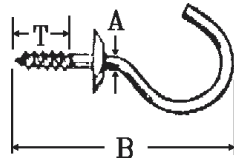

Made of solid brass.

Part No.	(A) Wire Diameter	(B) Overall Length	(T) Thread Length	Pkg Qty
18-563	.072	3/4	1/4	100
18-564	.072	7/8	7/16	100
18-565	.091	1-1/8	3/8	100
18-566	.091	1-1/4	1/2	100
18-567	.120	1-1/2	1/2	100
18-568	.135	1-7/8	3/4	100
18-569	.135	2-1/4	3/4	100

# S Hooks

Heavy open design. Low carbon steel. Zinc plated.

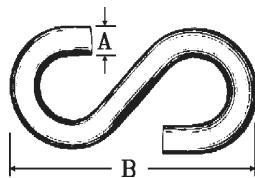

Part No.	(A) Wire Diam.	(B) Overall Length	Pkg Qty
18-570	.080	3/4	50
18-571	.090	1-1/16	50
18-572	.105	1-1/4	50
18-573	.120	1-1/2	50
18-574	.159	1-7/8	50
18-575	.185	2-1/8	50
18-576	.212	2-1/2	50
18-577	.328	3-1/4	50



# 800 Amp Super Clamps!



See page 189



# Wedge Anchors

(Stud Anchors)

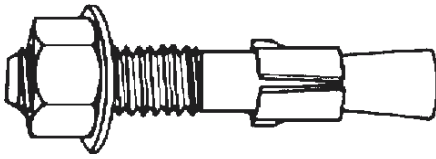

Wedge anchors are used for heavy duty fastening to concrete, brick or stone. Fastens steel plates and angles, wood studs, pipe supports, elevator equipment, conveyors, signs, hand rails, machinery and more. Full bodied diameter provides maximum bolt strength and prevents "wobbling" of the anchor in the hole. ASTM A108, A510. Zinc plated low carbon steel<sup>2</sup> or T303 stainless steel. Shipped unassembled.

**NOTE: BOLT SIZE IS HOLE SIZE**

1. Drill hole at depth of 4½ times anchor diameter.
2. Insert anchor 3. Tighten nut.

**!new T303 STAINLESS STEEL!**

Steel P/N	T303 S/S P/N	Dia. x O.A. Length	Pullout 4000 PSI Concrete <sup>1</sup>	Pkg Qty
23-216	-	1/4 x 1-3/4	1,170	100
23-217	-	1/4 x 2-1/4	1,170	100
23-218	-	1/4 x 3-1/4	1,170	100
23-219	23-037	3/8 x 2-1/4	5,150	100
23-220	-	3/8 x 2-3/4	5,150	100
23-221	23-038	3/8 x 3	5,150	100
23-222	-	3/8 x 3-3/4	5,150	100
23-223	23-040	3/8 x 5	5,150	50
23-225	23-042	1/2 x 3-3/4	7,450	50
23-226	23-055	1/2 x 4-1/4	7,450	25
23-227	-	1/2 x 5-1/2	7,450	25
23-228	-	1/2 x 7	7,450	25
23-229	23-056	5/8 x 3-1/2	8,670	25
23-230	-	5/8 x 4-1/2	8,670	25
23-231	23-057	5/8 x 5	8,670	25
23-232	-	5/8 x 6	8,670	25
23-233	-	5/8 x 7	8,670	25
23-235	-	3/4 x 4-3/4	12,300	20
23-236	-	3/4 x 5-1/2	12,300	20
23-237	-	3/4 x 7	12,300	10
23-238	-	3/4 x 8-1/2	12,300	10
23-239	-	3/4 x 10	12,300	10
23-240	-	1 x 6	27,250	5
23-241	-	1 x 9	27,250	5
23-242	-	1 x 12	27,500	5

<sup>1</sup> Pullout strength is approximate standard test values and is base on type of material listed. Values for other materials available on request. Safe working load limit should not exceed 25% of these stated values.

<sup>2</sup> Wedge Anchors also available in T316 stainless and galvanized coated

<sup>3</sup> Wej-It Anchors also available in T303 stainless, T316 stainless and galvanized coated (subject to minimum packaging).

# WEJ-IT® Wedge Anchors

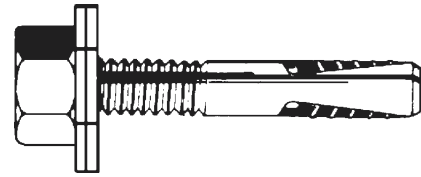

Time-tested and proven reliable. Patented wedge action provides highest strength values available. Unique design eliminates anchor rotation, minimizes loosening due to vibration. Made from high strength cold rolled steel<sup>3</sup>. Zinc plated and acetate coated. Meets ASTM-117 salt spray test. Meets OSHA 1910.212(B). Shipped assembled and ready-to-use.

**NOTE: BOLT SIZE IS HOLE SIZE**

1. Drill hole. 2. Insert anchor. 3. Tighten nut.

Part No.	Dia. x O.A. Length	Minimum Embed -ment	Pullout 5000 PSI Concrete <sup>1</sup>	Pkg Qty
23-000	1/4 x 1-3/4	1"	1,760	100
23-001	1/4 x 2-3/4	1"	1,760	100
23-002	1/4 x 3	1"	1,760	100
23-004	5/16 x 2	1-1/4	2,742	100
23-005	5/16 x 3	1-1/4	2,742	100
23-006	3/8 x 2	1-1/2	3,834	100
23-007	3/8 x 2-3/4	1-1/2	3,834	100
23-008	3/8 x 3-1/2	1-1/2	3,834	50
23-009	3/8 x 5	1-1/2	3,834	50
23-010	3/8 x 6	1-1/2	3,834	50
23-011	1/2 x 2-3/4	2"	5,789	50
23-012	1/2 x 3-1/2	2"	5,789	50
23-013	1/2 x 5	2"	5,789	25
23-014	1/2 x 6	2"	5,789	25
23-015	1/2 x 7	2"	5,789	25
23-016	5/8 x 3-1/2	3"	12,636	25
23-017	5/8 x 4-1/2	3"	12,636	25
23-018	5/8 x 5	3"	12,636	20
23-019	5/8 x 6	3"	12,636	15
23-020	5/8 x 7	3"	12,636	15
23-021	3/4 x 4	3"	19,299	18
23-022	3/4 x 5	3"	19,299	12
23-023	3/4 x 6	3"	19,299	12
23-024	3/4 x 7	3"	19,299	10

# Lead Machine Screw Anchors

(Caulking Anchors)

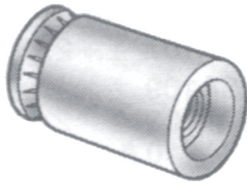

A quick setting anchor for use with screws or machine bolts in hollow and solid masonry, concrete, brick and stone. Can be used in shallow-hole applications. Lead sleeve with rust resistant zinc alloy cone†.

Part No.	Size	Drill Size	Anchor Length	Holding Power*	Pkg Qty
23-029	1/4-20	1/2	7/8	2200 lbs	100
23-030	5/16-18	5/8	1"	3100 lbs	100
23-031	3/8-16	3/4	1-1/4	5500 lbs	50
23-032	1/2-13	7/8	1-1/2	6310 lbs	50

# Drop-In Anchors

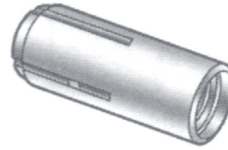

Flush mount female threaded anchor with an internal plug for heavy duty applications. Provide high holding strengths with relatively shallow imbedment depths in concrete, solid block and stone. Ideal for installing rod or machine bolts in overhead applications. To install, insert anchor into a predrilled hole and tap flush with the surface. Drive the setting tool† into the anchor until the tool's shoulder is seated against the anchor. The internal plug is driven to exactly the right depth, causing the anchor to expand. Then, insert a bolt or threaded rod and tighten. Made from carbon steel.

Part No.	Bolt Diam.	Anchor Length	Drill Size	Holding Power*	Pkg Qty
23-025	1/4-20	1"	3/8	2200 lbs	100
23-027	3/8-16	1-9/16	1/2	5000 lbs	100
23-035	1/2-13	2"	5/8	8000 lbs	50

Large sizes available (subject to package minimum).

# Anchor Bolts w/Hex Nuts & Flat Washers

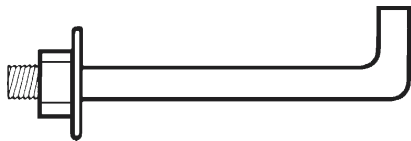

Also known as foundation hook bolts, these L-style bent bolts have a right-angle hook, typically cast into concrete foundations. Used to anchor walls, sill plates, machinery, etc. Made from A36 low carbon steel. Tensile strength: 55,000 psi. min. Plain finish.

Part No.	Size	Pkg Qty
23-186	3/8-16 x 6"	50
23-187	3/8-16 x 8"	50
23-188	1/2-13 x 6"	50
23-189	1/2-13 x 8"	50
23-190	3/4-10 x 15"	25
23-191	3/4-10 x 18"	25

Special sizes made to order. J-bolts and 45° hold-downs also available on request (subject to minimum packaging).

# Double Expansion Shield Anchors



The double expansion anchor is manufactured of rustproof zinc alloy, and is used with machine bolts or screws. It works well in soft masonry and mediums of questionable strength. As the "double" sets, the two opposing wedges pull towards each other, expanding the full length of the anchor body. Proper expansion requires that anchor, prior to setting, protrudes slightly above surface plane.

Part No.	Bolt Diam.	Anchor Length	Drill Size	Holding Power*	Pkg Qty
23-061	1/4-20	1"	1/2	1990 lbs	100
23-062	5/16-18	1-1/4	5/8	2250 lbs	50
23-063	3/8-16	2"	3/4	4010 lbs	50
23-064	1/2-13	2"	7/8	4880 lbs	25
23-065	5/8-11	2-1/4	1"	6200 lbs	25
23-066	3/4-10	2-7/8"	1-1/4	9650 lbs	10

\*Safe working load limit is 25% of holding power. †Drive tool provided with each package of anchors.

# Concrete Screws

Tap-Con™ Style<sup>1</sup>

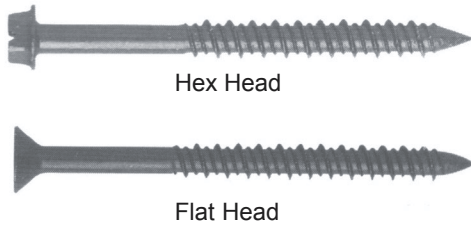

Hex Head

Flat Head

Concrete screws provides fast, secure anchoring, utilizing a hardened screw with specially designed high-low threads which cut into a properly sized hole and thread into concrete, masonry, brick, block, stone, etc. Installation requires use of specially designed carbide drills<sup>2</sup>, and becomes an even faster operation when used with the concrete screw installation tool (23-281). This system eliminates the need for plastic anchors and lead anchors in medium and light duty applications. Removable and reusable. Can be removed without excessive damage to surrounding surfaces<sup>3</sup>. *No layout or hole spotting required.* Made from case hardened steel. Corrosion resistant finish. Color: blue.

**ONE FREE DRILL INCLUDED WITH EACH PACKAGE OF 100 CONCRETE SCREWS**

Anchor Size	Part Number		Pkg Qty	Drill Used
	Hex Hd.	Flat Hd.		
3/16 x 1-1/4	23-256	23-268	100	23-288
3/16 x 1-3/4	23-257	23-269	100	23-288
3/16 x 2-1/4	23-258	23-270	100	23-282
3/16 x 2-3/4	23-259	23-271	100	23-282
3/16 x 3-1/4	23-260	23-272	100	23-284
3/16 x 4"	23-261	23-273	100	23-284
1/4 x 1-1/4	23-262	23-274	100	23-287
1/4 x 1-3/4	23-263	23-275	100	23-287
1/4 x 2-1/4	23-264	23-276	100	23-285
1/4 x 2-3/4	23-265	23-277	100	23-285
1/4 x 3-1/4	23-266	23-278	100	23-286
1/4 x 4"	23-267	23-279	100	23-286

<sup>1</sup>Not affiliated with Tap-Con®, a registered trademark of the ITW Buildex Corp. <sup>2</sup>Warning: A substitution of supplied drills could result in fastening failure. Only use concrete screw drills with this product. <sup>3</sup>Concrete screws must be fastened within 1/2" of a slab edge. Ultimate load values available on request.

## CONCRETE SCREW ASSORTMENT

11 SIZES.  
3/16 & 1/4" HEX HEAD AND FLAT HEAD PHILLIPS CONCRETE SCREWS TO 3-1/4" LG.  
PLUS 2 DRILLS. IN A LARGE STEEL DRAWER.  
**PART NO. 23-281**



# Concrete Screw Drills



The standard masonry drill supplied with concrete screws. Split shank configuration fits properly in the installation tool. High quality carbide tip. Black oxide finish.

*Warning: Concrete screw drills have special dimensions, and a substitution may result in fastening failure.*

Part No.	Drill Size	For Screw Diameter
23-288	5/32 x 3-1/2	3/16"
23-282	5/32 x 4-1/2	3/16"
23-284	5/32 x 5-1/2	3/16"
23-287	3/16 x 3-1/2	1/4"
23-285	3/16 x 4-1/2	1/4"
23-286	3/16 x 5-1/2	1/4"

# Concrete Screw Installation Tool Kit



No more lost bits!

Complete with sturdy plastic case fitted for each accessory!

Magnetic Hex Insert Bits for 3/16" and 1/4" Screws



Drill Holder and Hex Key



Drive Tube/Bit Holder

For any brand of concrete screw. Includes tool to drill and install hex head and phillips head concrete screws. Works equally well with hammer drills or standard twist. Plastic storage case and installation instructions included. Fully guaranteed for one year. (Drills not included.)

**Part no. 23-281**

# Hammer Drive Anchors

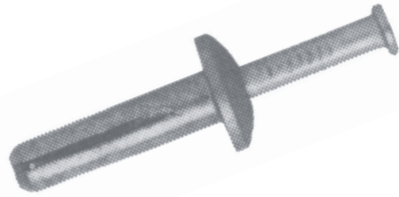

The body of the hammer drive anchor is made from high grade Zamac 3, a zinc alloy which provides high pullout values and rust resistance. Zamac 3 is also resistant to embrittlement which frequently occurs in lower grades of zinc alloys. Use in concrete, brick, block, and stone. Hammer drive anchors have a tamperproof mushroom (truss) head. Meets ASTM E-488-90 requirements. Shipped assembled.

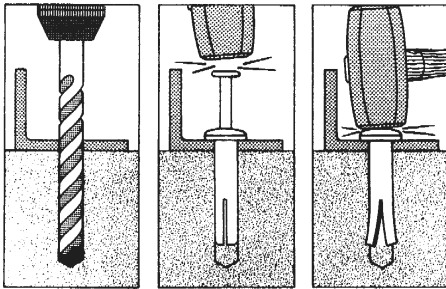

Part No.	Anchor Dia.	Anchor Length	Grip Range	Holding Power*	Pkg Qty
23-082	3/16	7/8	0-1/8	500 Lbs.	100
23-083	1/4	1"	1/8-1/4	820 Lbs.	100
23-084	1/4	1-1/4	1/4-1/2	970 Lbs.	100
23-085	1/4	1-1/2	1/2-3/4	1150 Lbs.	100
23-086	1/4	2"	3/4-1-1/4	1300 Lbs.	100

\* Safe working load is 25% of holding power.

# Lag Screw Shield Anchors

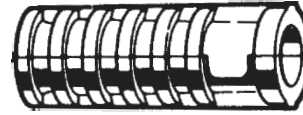

Lag screw shields are designed for light to medium duty fastening in concrete, mortar joints, masonry and brick. Achieves tighter grip in out-of-round holes. For medium to heavy service in all types of masonry. Exclusive "off-center" internal threads cause shield to *split and shift* when expanding to allow four points of contact. Hinged two-piece construction. For use with lag screws (sold separately), the screw length can be determined by adding the length of the anchor and the thickness of material, plus 1/4". Made from zinc alloy.

## SHORT STYLE

*Short length designed for use in hard masonry materials to minimize drilling time. Not effective in soft masonry materials of questionable strength (see long style below).*

Part No.	Screw Size	Anchor Length	Drill Size	Holding Power*	Pkg Qty
23-095	1/4	1"	1/2	1450	100
23-096	5/16	1-1/4	1/2	1510	100
23-097	3/8	1-3/4	5/8	1600	50
23-098	1/2	2"	3/4	2000	50

## LONG STYLE

*Designed for questionable or soft masonry materials. May also be used in hard masonry for superior holding power.*

Part No.	Screw Size	Anchor Length	Drill Size	Holding Power*	Pkg Qty
23-099	1/4	1-1/2	1/2	1620	100
23-100	5/16	1-3/4	1/2	1700	100
23-101	3/8	2-1/2	5/8	1850	50
23-102	1/2	3"	3/4	2800	50

\* Safe working load is 25% of holding power.

# Nylon Nail Anchors

(Nylon Drive Anchors)

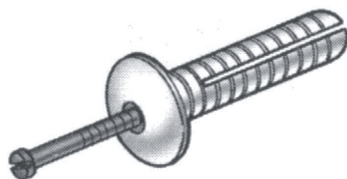

Use in hollow walls or solid materials for light duty fastening in concrete, block, brick, plastic, wallboard, sheet metal, wood, plaster, glass, slate, marble and tile. Zinc coated high carbon steel nail is slotted for easy removal. Shipped assembled. Drill size: 1/4". 9/16" dia. truss head. Pkg: 100 each

Part No.	Anchor Diameter	Anchor Length	Holding Power*	
			Shear	Tensile
23-119	1/4"	3/4	884#	261#
23-120	1/4"	1"	884#	261#
23-121	1/4"	1-1/2	951#	320#
23-122	1/4"	2"	972#	320#

\*Safe working load limit is 25% of holding power.

# Plastic Screw Anchors

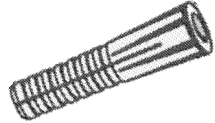

Hands down...this is the toughest, most durable plastic screw anchor design yet. Horizontal ribs for *superior pull-out strength*, helps prevents anchor from falling out in overhead positions. Vertical rib design stops anchor from turning. Applications: telephones, panels, signs, mirrors, conduit straps, cabinets, draperies, blinds and other light weight wall-mounted accessories. Corrosion-proof, weather and impact resistant. Color: white.

Part No.	Screw Range	Drill Size	Anchor Length	Pkg Qty
23-111	6-8	3/16	7/8	100
23-112	10-12	1/4	1"	100
23-113	14-16	5/16	1-1/4	100



### 6-8 PLASTIC SCREW ANCHOR KIT

100 PCS 6-8 ANCHORS, 100 PCS #6 X 3/4" PAN HD SLOTTED SCREWS, ONE 3/16" CARBIDE TIP DRILL, REUSABLE PLASTIC BOX. **PART NO. 23-114**

### 10-12 PLASTIC SCREW ANCHOR KIT

100 PCS 10-12 ANCHORS, 100 PCS #10 X 1" PAN HD SLOTTED SCREWS, ONE 3/16" CARBIDE TIP DRILL, REUSABLE PLASTIC BOX. **PART NO. 23-115**

### 12-14 PLASTIC SCREW ANCHOR KIT

50 PCS 12-14 ANCHORS, 50 PCS #12 X 1-1/2" PAN HD SLOTTED SCREWS, ONE 3/16" CARBIDE TIP DRILL, REUSABLE PLASTIC BOX. **PART NO. 23-116**

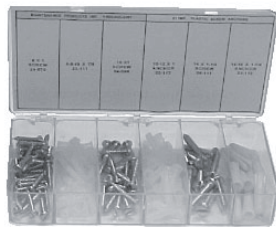

### PLASTIC SCREW ANCHOR KIT

6-8, 10-12, AND 12-14 ANCHORS, 8 X 1", 10 X 1" AND 14 X 1" WITH SLTD PAN HD. SMS, STYRENE BOX. **PART NO. 511MK**

# Ribbed Plastic Screw Anchors



Deep ribbed body provides improved pullout strength. Vertical rib design stops anchor from turning. Use in brick, concrete, drywall and masonry.

Part No.	Screw Range	Drill Size	Anchor Length	Pkg Qty
23-103	6-8	3/16	3/4	100
23-104	10-12	1/4	1"	100
23-105	14-16	5/16	1-1/4	100

# Toggler Anchors

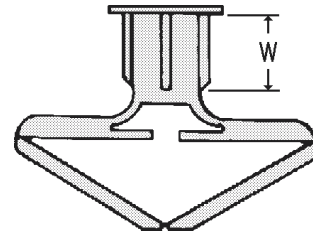

All purpose screw anchor for use in hollow walls, thick walls and solid construction materials. Accepts no. 8, 10 or 12 type A tapping screws. Minimum 1-1/4" screw length. Made of high grade plastic. Noncorrosive and nonconductive.

### LOAD LIMITS/ DRILL SIZES

Used as...	Max. Load limit	Drill Size
A toggle	Up to 100 lbs	5/16"
A wedge	Up to 590 lbs	3/8"

Part No.	(W) Wall Thickness	Grip Range	Pkg Qty
23-147	3/8"	5/16" - 7/16"	100
23-148	1/2"	7/16" - 9/16"	100
23-149	5/8"	9/16" - 11/16"	100

# Wallboard Anchors



SELF-DRILLING  
NO HOLE PREPARATION

Self-piercing points cuts right through 3/8" to 5/8" thick drywall without predrilling. Use with standard #8 sheet metal screws†. Use anywhere plastic screw anchors or toggle bolts are used. No power tools required for installation or removal. Use a common #2 phillips screwdriver or for high volume installations use a power screwdriver. Material: Zinc Alloy or Nylon.

Part No.	Type	Holding Power‡
23-185 .....	Zinc Alloy .....	110 lbs.
23-195 .....	Nylon .....	80 lbs.

†Screws must be ordered separately.

‡ Strength tested with #8 screw in 1/2" thick drywall.

**WALLBOARD ANCHOR KITS**  
INCLUDES ANCHORS, PHILLIPS SHEET METAL SCREWS AND FLAT WASHERS IN A CLEAR STYRENE BOX.

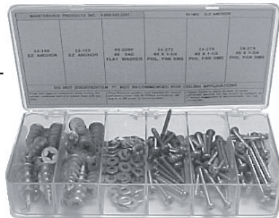

541MK.. ZINC WALLBRD ANCHORS  
546MK.. NYLON WALLBRD ANCHORS

# Hollow Wall Anchors

(Molly Anchors)

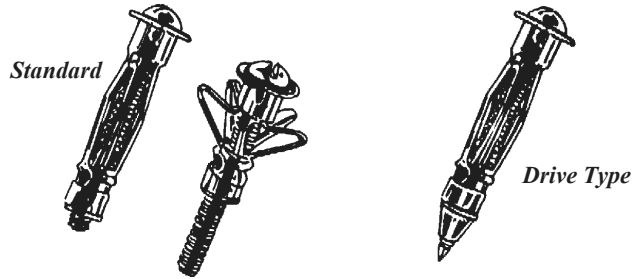

Designed to be used in materials such as wallboard, plaster, paneling, hollow block, etc. Prongs underhead keep the anchor from rotating while being set. The anchor expands behind the surface as the screw is tightened. Once set, the screw may be removed as often as necessary. For faster or high volume installations use the setting tool shown below. Bright zinc finish.



Part No.	Trade Size	Grip Range	Screw Size	Hole Size	Body Length	Pkg Qty
<b>STANDARD HOLLOW WALL ANCHORS</b>						
23-150 ...	1/8 X-SHORT	1/16-1/4	6-32	5/16	3/4	100
23-151 ...	1/8 SHORT	1/8-1/2	6-32	5/16	1-1/4	100
23-152 ...	1/8 LONG	5/8-7/8	6-32	5/16	1-5/8	100
23-153 ...	1/8 X-LONG	1 1/4 - 1 1/2	6-32	5/16	2-1/4	100
23-154 ...	3/16 SHORT	1/8-5/8	10-24	3/8	2-1/16	50
23-155 ...	3/16 LONG	5/8-1-3/16	10-24	3/8	2-1/2	50
23-157 ...	1/4 SHORT	1/8-5/8	1/4-20	1/2	2-1/16	50
23-158 ...	1/4 LONG	5/8-1-3/16	1/4-20	1/2	2-1/2	50
<b>DRIVE TYPE HOLLOW WALL ANCHORS</b>						
23-209 ...	1/8 SHORT	1/8-1/2	6-32	5/16	1-3/4	100
23-210 ...	1/8 LONG	5/8-7/8	6-32	5/16	2-11/32	100

# Vinyl Screw Anchors

(Vinyl Plugs or Tubular Anchors)

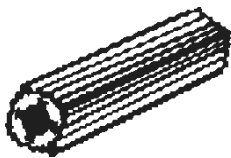

The original "plastic screw anchor" is made of tough and durable vinyl. Cut-to-length as needed. Use with metal screws and lag screws in a variety of solid and hollow materials such as concrete, brick, masonry, wood, plaster and drywall. Pkg. 100 each.

Part No.	Screw Size	Drill Size	Anchor Length	Color
23-135 .....	10-12 .....	1/4 .....	1" .....	Green
23-137 .....	10-12 .....	1/4 .....	1-1/2 .....	Green
23-139 .....	14-1/4 .....	5/16 .....	1" .....	Blue
23-140 .....	14-1/4 .....	5/16 .....	1-1/2 .....	Blue

# Hollow Wall Anchor Setting Tool



Easy to use. Replace the tiresome old screwdriver method with a fast and easy method of installing hollow wall anchors. Great for high volume installations and tight corners. Quick release trigger. Cushion grip handles. **Part No. 10-497**

(Note: 10-497 is also used as a Jack Nut® installation tool. See page 51.)

# Toggle Bolts

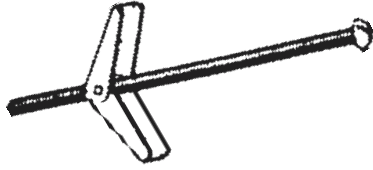

Excellent holding power in all types of hollow materials such as drywall, plaster, glass, concrete or cinder block. Includes both round head slotted machine screws and toggle wings. Zinc finish.

Part No.	Dia.	Length	Drill Size*	Pkg Qty
23-160	1/8 (6-32)	2"	3/8	50
23-161	1/8 (6-32)	3"	3/8	50
23-162	1/8 (6-32)	4"	3/8	50
23-164	3/16 (10-24)	3"	1/2	50
23-165	3/16 (10-24)	4"	1/2	50
23-166	3/16 (10-24)	5"	1/2	50
23-167	3/16 (10-24)	6"	1/2	50
23-168	1/4-20	3"	5/8	50
23-169	1/4-20	4"	5/8	50
23-170	1/4-20	5"	5/8	50
23-171	1/4-20	6"	5/8	50

\* In hard materials, drill holes 1/16" larger than size shown.

Length measured from under head.

For sizes not listed, order Machine Screws and Toggle Wings (below) separately.

# Toggle Wings



Heavy duty toggle wings have appropriate sizing stamped on the wings for easy identification. Zinc finish.

Part No.	Size	Wing Length	Hole Size	Pkg Qty
23-179	1/8 (6-32)	1-3/4"	3/8"	100
23-180	3/16 (10-24)	2-1/4"	1/2"	100
23-181	1/4-20	2-1/4"	5/8"	100
23-182	5/16-18	2-3/4"	7/8"	50
23-183	3/8-16	3-1/4"	1"	50
23-184	1/2-13	5"	1-1/4"	25

# Kap-Toggle®

## Heavy Duty Hollow Wall Anchors

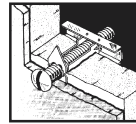
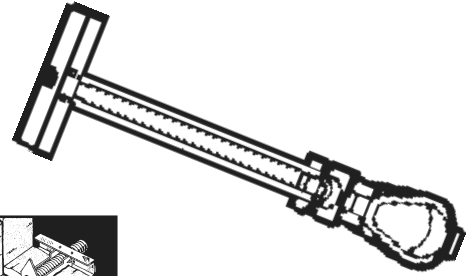

- **EASY TO USE** - Pre-installs without screw.
- **ACCURATE** - Pre-installation mechanism centers and holds Kap-Toggle in place, before inserting screw.
- **FAST** - Allows use of screw gun or regular screwdriver.
- **CONVENIENT** - Enables removal of bolt/fixture without anchor falling behind wall.
- **RELIABLE** - Will not damage or break through wall, even under vibratory load.
- **MADE IN U.S.A.**

**Superior holding power for heavy duty attachments to hollow walls or ceilings.** Railings, plumbing, towel bars, hanging planters, gates, boat attachments, sinks, speakers, ceiling fans, lighting fixtures, mirrors, shelving, racks, electrical panels, door tracks, fire equipment.

**Use in any hollow core substrate.** Drywall, sheet rock, paneling, stucco, hollow brick, plaster, wood, gypsum board, cinder block, concrete and fiberglass.



1. INSERT IN HOLE

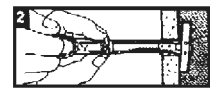

2. ZIP FLUSH WITH SURFACE



3. SNAP OFF FLUSH WITH SURFACE

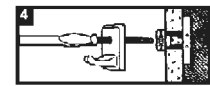

4. DRIVE SCREW FLUSH (SCREWS NOT INCLUDED)

Part No.	Bolt Size	Hole Size	Grip Range	W.L.L.*		Pkg Qty
				1/2" Drywall	Cinder Block	
23-192	6-32	3/8"	2"	37#	102#	50
23-193	10-24	1/2"	2-1/2"	38#	150#	50
23-194	1/4-20	5/8"	2-1/2"	40#	300#	50

\*Working Load Limit. Use with machine screws same as toggle bolt sizes. Screws must be ordered separately.

# Rivet Tools and Parts, Rivet Assortments

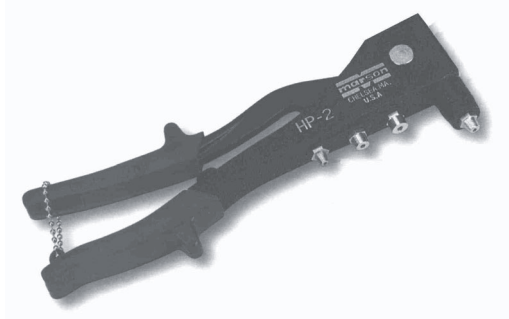

## Deluxe Hand Riveter

For 3/32", 1/8", 5/32", and 3/16" diameter aluminum and steel rivets. Die cast aluminum alloy body. Heat treated steel upper handle. Long life jaws. Made in the U.S.A. by Marson. **Part no. 20-915**



## Big Daddy® Rivet Tool

Our most versatile and powerful hand riveter takes the hard work out of setting large diameter blind rivets, in all alloys. Its extra-long handles provide extra leverage and permit working a foot beyond natural reach. The Big Daddy comes with 5/32", 3/16", and 1/4" nosepieces which are stored in the body. Weight: 3.75 lbs. Made in the U.S.A. by Marson. **Part no. 20-918**



## Deluxe Riveter Kit

Includes deluxe hand rivet tool (20-915 above) plus 200 assorted rivets in popular sizes. Molded plastic case houses and protects contents. Made in the U.S.A. by Marson. **Part no. 20-916**



SPACE FOR  
OPTIONAL RIVET  
GUN

**ALUMINUM BLIND RIVET ASSORTMENT**  
CONTAINS 6 SIZES, 1/8" AND 3/16" DIAMETER  
ALL-ALUMINUM RIVETS IN LARGE ADJUSTABLE DRAWER.  
**PART NO. 16-4806**

## The Kliker®

The perfect medium-duty riveting tool comes with a small assortment of rivets and backup washers. Rivets are automatically held in tool regardless of tool angle. Sets aluminum rivets in 1/8", 5/32" and 3/16" diameters. Sets steel rivets in 1/8" and 5/32" diameters. Packaged in plastic pouch. Imported by Marson. **Part no. 20-917**



## Riveter Nosepieces & Jaw Sets

**PARTS FOR DELUXE RIVETER**  
(20-915) **KLIKER®** (20-917)  
*Marson models HP-2 (39000) and Kliker (39040)*

Part No.	Item
20-919	3/32 Nosepiece (M8 x 1.25)
20-920	1/8 Nosepiece (M8 x 1.25)
20-921	5/32 Nosepiece (M8 x 1.25)
20-922	3/16 Nosepiece (M8 x 1.25)
20-927	Jaw Set (2)



**PARTS FOR BIG DADDY®**  
**RIVETER** (20-918) Marson model 39031

Part No.	Item
20-923	1/8 Nosepiece (M10 x 1.0)
20-924	5/32 Nosepiece (M10 x 1.0)
20-925	3/16 Nosepiece (M10 x 1.0)
20-926	1/4 Nosepiece (M10 x 1.0)
20-928	Jaw Set (2)





# Blind Rivets



- For blind fastening where there is no access to opposite side of work.
- Vibration and tamper resistant. • Simple to install
- Securely fastens thin and thick applications in most materials.
- Low head profile head for a snag-free smooth appearance.

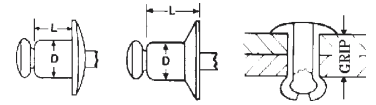

Grip Range		(L) Rivet Length	Alum. Rivet Alum. Stem	Alum. Rivet Steel Stem	Steel Rivet Steel Stem
Min.	Max.				
<b>1/8" DIA. (D) DOME HEAD</b> • Drill size: 30					
.020	1/16	.212	20-002	-	-
.063	1/8	.275	20-003	20-028	20-054
.188	1/4	.400	20-004	20-029	20-055
.313	3/8	.525	20-005	20-030	20-056
.376	1/2	.650	20-006	20-031	20-057
<b>1/8" DIA. (D) LARGE FLANGE</b> • Drill size: 30					
.032	1/8	.275	20-007	20-032	20-058
.188	1/4	.400	20-008	20-033	20-059
<b>1/8" DIA. (D) 120° COUNTERSUNK</b> • Drill size: 30					
.062	1/8	.300	20-009	20-034	20-060
.188	1/4	.425	20-010	20-035	20-061

(Actual Size Pictures)

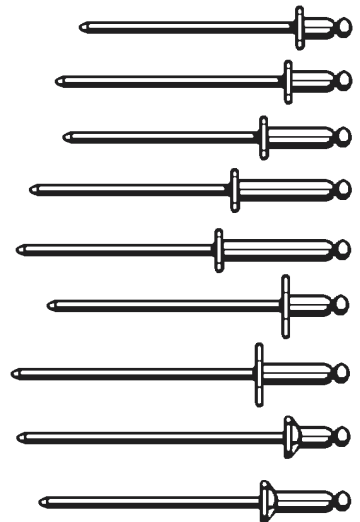

<b>5/32" DIA. (D) DOME HEAD</b> • Drill size: 20					
.062	1/8	.300	20-011	20-036	20-062
.188	1/4	.425	20-012	20-037	20-063
.251	3/8	.501	20-013	20-038	20-064
.376	1/2	.675	20-014	20-039	20-065

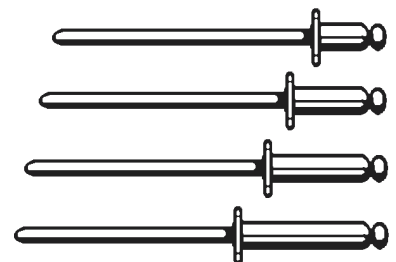

<b>3/16" DIA. (D) DOME HEAD</b> • Drill size: 11					
.062	1/8	.325	20-015	20-040	20-066
.126	1/4	.450	20-016	20-041	20-067
.251	3/8	.571	20-017	20-042	20-068
.376	1/2	.700	20-018	20-043	20-069
.501	5/8	.825	20-019	20-044	20-070
.626	3/4	.950	20-020	20-045	20-071

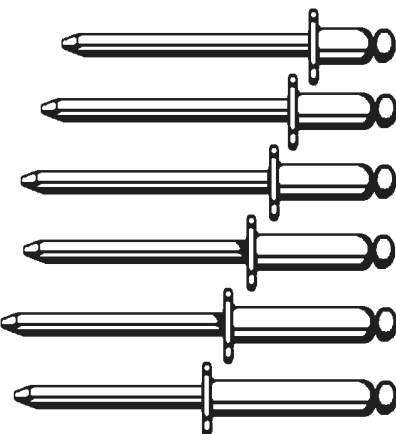

All Pkg. Qty. — 250 each

(Continued next page)

# Blind Rivets (Cont'd)



Grip Range		(L) Rivet Length	Alum. Rivet Alum. Stem	Alum. Rivet Steel Stem	Steel Rivet Steel Stem	(Actual Size Pictures)
Min.	Max.					

## 3/16" DIA. (D) LARGE FLANGE • Drill size: 11

.251	3/8	.575	20-022	20-047	20-073	
.376	1/2	.700	20-023	20-048	20-074	
.501	5/8	.825	-	20-049	20-075	
.626	3/4	.950	20-025	20-050	20-076	

All Pkg. Qty. — 250 each

## 1/4" DIA. (D) DOME HEAD • Drill size: F

.125	1/4	.500	-	-	20-078	
.251	3/8	.625	-	20-052	20-079	
.376	1/2	.750	-	-	20-080	
.501	3/4	1.000	-	-	20-082	

All Pkg. Qty. — 100 each

## Special Blind Rivets



Part No.	Dia.	Grip Range		Rivet Length
		Min.	Max.	
<b>All T305 Stainless Steel, Dome Head</b>				
20-215	1/8	.188	1/4	.400
20-216	3/16	.126	1/4	.450
<b>Painted All Aluminum, White Dome Head</b>				
20-213	1/8	.063	1/8	.275
20-214	1/8	.188	1/4	.400

All Pkg. Qty. — 250 each

## Backup Washers



Reinforces blind rivets in soft materials.  
Thickness: .056".

Part No.	SIZE		Material
	I.D.	O.D.	
20-086	1/8"	3/8"	Steel
20-087	5/32"	7/16"	Aluminum
20-088	3/16"	1/2"	Steel



## QUALITY THREAD INSERT SYSTEMS

### FEATURES

Recoil helically-wound inserts are formed from 18-8 (Type 304) stainless steel rhomboidly shaped by cold rolling. The resultant wire in most sizes has a tensile strength of greater than 200,000 P.S.I. The wire is then wound to the shape of a spring thread, then when installed into Recoil tapped holes it provides a permanent, wear-resistant thread which in most cases exceeds the strength of the parent thread. Recoil inserts are available in most thread types and sizes including UNC, UNF, BSW, BSP, BSF, BA, NPT and metric.

The Recoil insert is held in place because the free diameter of the insert is larger than the tapped hole. The act of installation compresses the spring then the spring-back action permanently anchors the insert in place.

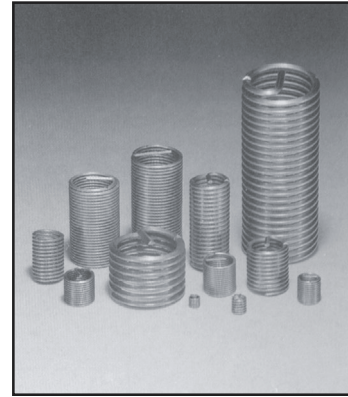

### CHARACTERISTICS

Recoil inserts have a number of important characteristics.

1. Under static and dynamic loading, Recoil inserts increase the strength of a fastening assembly, thus increasing reliability.
2. Recoil inserts use 18-8 (Type 304) stainless steel for optimum cost benefit and corrosion resistance. This also assists in reducing torque friction and thread wear a long time after original manufacture, compared to parent materials.
3. Recoil inserts compensate for pitch and angle errors and share the load level over more of the thread for strong assemblies.
4. Recoil inserts allow for greater design flexibility, allow a larger selection of materials and subsequent design shapes for greater overall concept flexibility.
5. Recoil inserts can be installed in reduced bosses, flanges and within constricted areas thus saving weight and space and still providing high strength, compared with solid wall and bush-type inserts.
6. Recoil inserts have a wide temperature tolerance between -270°F to +774°F (-150°C to +430°C).
7. Recoil inserts are *interchangeable* with other helically wound systems.
8. Recoil inserts are simpler and easier to use compared with other helically wound systems.

#### Drill

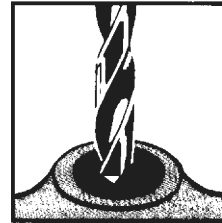

Drill to clear out the damaged thread (if necessary).

#### Tap

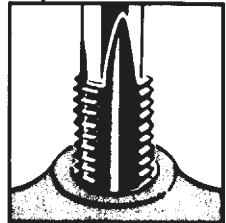

Thread insert tap supplied should match up with bolt.

#### Install

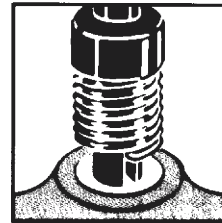

Wind insert in with light downward pressure until  $\frac{1}{4}$  to  $\frac{1}{2}$  turn below surface, driving tang towards bottom of the hole.

#### Tang Removal



Remove tool and sit back on top of tang. Tap down sharply. Do not try to twist tang off. Sparkplug and large fine threads, use long nose pliers and pull tang out.



# Thread Repair Kits

## INCH SIZES

Recoil creates and repairs stripped or damaged threads better than original!

Inserts are made from corrosion resistant 18-8 stainless steel.

Tensile strength: 200,000 psi.

Temperature tolerance: -270° to +774°F.

Interchangeable with other popular helical thread insert systems... the most universally accepted method of thread repair.

Can be used in almost any material... Steel, stainless steel, aluminum, magnesium, brass, cast iron, even plastic!

Recoil inserts are stackable!  
Unlisted sizes and lengths available....Recoil makes them all!

### Recoil Master Range Kits

Complete master range kits are stocked in coarse and fine threads. Each kit includes all required STI taps, installation-tang break off tools, and thread inserts in an impact resistant plastic case.

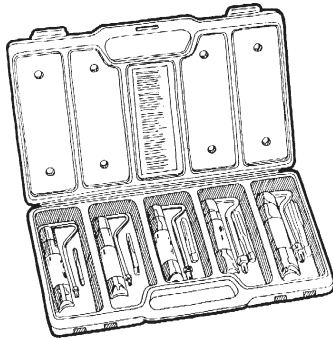

#### MASTER RANGE KIT - COARSE THREAD

5 sizes: 1/4-20, 5/16-18, 3/8-16, 7/16-14 and 1/2-13.  
**PART NO. 33004**

#### MASTER RANGE KIT - FINE THREAD

5 sizes: 1/4-28, 5/16-24, 3/8-24, 7/16-20 and 1/2-20. **PART NO. 34004**

*We also stock Metric Master Range Kits.*

### UNC/UNF

### Individual Size Repair Kits



Each individual size repair kit includes one high quality STI tap, one installation-tang break off tool, and a quantity of inserts in a sturdy steel case.

Size	Kit Part No.	Inserts Per Kit	Drill Size
<b>COARSE THREAD</b>			
8-32	33580	10	11/64
10-24	33600	10	13/64
12-24	33620	10	15/64
1/4-20	33040	10	17/64
5/16-18	33050	10	21/64
3/8-16	33060	10	25/64
7/16-14	33070	10	29/64
1/2-13	33080	5	17/32
9/16-12	33090	5	19/32
5/8-11	33100	5	21/32
3/4-10	33120	5	25/32
7/8-9	33140	5	29/32
1-8	33160	5	1-1/32
<b>FINE THREAD</b>			
10-32	34600	10	13/64
1/4-28	34040	10	17/64
5/16-24	34050	10	21/64
3/8-24	34060	10	25/64
7/16-20	34070	5	29/64
1/2-20	34080	5	33/64
9/16-18	34090	5	37/64
5/8-18	34100	5	41/64
3/4-16	34120	5	49/64
7/8-14	34140	5	57/64
1-14	34170	5	1-1/64

The easiest way to get rid of a difficult task is to do it.

# RECOIL Inserts

18-8 (T304) stainless steel inserts. Corrosion resistant. No pre-winding. *Interchangeable* with other helical systems. Stackable. Wide temperature tolerance (-270°F to +774°F). Meets current military (MS) and aircraft (AN) specifications. May be used in many materials such as steel, stainless steel, exotic alloys, magnesium, cast iron, plastics, and aluminum.

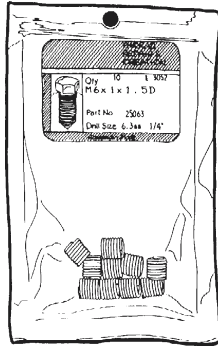

## Inch Sizes

Insert Size	Insert Length	Part No.	Heli-Coil Cross-ref.	Pkg Qty
<b>COARSE THREAD</b>				
4-40	.152	23543	-	10
6-32	.191	23563	-	10
8-32	.246	23583	R1185-2	10
10-24	.285	23603	R1185-3	10
12-24	.324	23623	R1185-1	10
1/4-20	.375	23043	R1185-4	10
5/16-18	.469	23053	R1185-5	10
3/8-16	.562	23063	R1185-6	10
7/16-14	.656	23073	R1185-7	10
1/2-13	.750	23083	R1185-8	10
9/16-12	.844	23093	R1185-9	5
5/8-11	.938	23103	R1185-10	5
3/4-10	1.125	23123	R1185-12	5
7/8-9	1.312	23143	K1185-14	3
1-8	1.50	23163	K1185-16	3
<b>FINE THREAD</b>				
10-32	.285	24603	R1191-3	10
1/4-28	.375	24043	R1191-4	10
5/16-24	.469	24053	R1191-5	10
3/8-24	.562	24063	R1191-6	10
7/16-20	.656	24073	R1191-7	10
1/2-20	.750	24083	R1191-8	10
9/16-18	.844	24093	R1191-9	5
5/8-18	.938	24103	R1191-10	5
3/4-16	1.125	24123	R1191-12	5
7/8-14	1.312	24143	K1191-14	3
1-14	1.50	24163	K1191-16	3

Also available on request; Bulk quantities, special lengths, special threads, self-locking inserts, strip-feed inserts, special taps, prewinders for fine threads, power insertion tools and extraction tools.

# RECOIL STI Taps

(Screw Thread Insert Taps)



## Inch Sizes

For use with Recoil® Inserts\*

Intermediate (universal plug) tap manufactured to the H-limit requirements for Recoil helical style inserts. These ground thread taps are made from quality high speed steel. Pkg. 1 each

Thread Size	Part No.	HeliCoil Cross-ref
<b>COARSE THREAD</b>		
4-40	43545	-
6-32	43565	-
8-32	43585	819-2
10-24	43605	819-3
12-24	43625	819-1
1/4-20	43045	819-4
5/16-18	43055	819-5
3/8-16	43065	819-6
7/16-14	43075	819-7
1/2-13	43085	819-8
9/16-12	43095	819-9
5/8-11	43105	819-10
3/4-10	43125	819-12
7/8-9	43145	8187-14
1-8	43165	8187-16
<b>FINE THREAD</b>		
10-32	44605	821-3
1/4-28	44045	821-4
5/16-24	44055	821-5
3/8-24	44065	821-6
7/16-20	44075	821-7
1/2-20	44085	821-8
9/16-18	44095	821-9
5/8-18	44105	821-10
3/4-16	44125	821-12
7/8-14	44145	8193-14
1-14	44175	8193-16

\*Interchangeable with HeliCoil® brand STI Taps.

These special STI taps are also available on request... taper, bottoming, pilot nose, spiral point, and spiral flute. Call for more information.



# Metric Thread Repair Kits



## Metric Range Kits

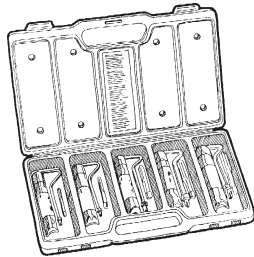

Includes high quality taps, installation-tang break-off tools, inserts, and instructions, in a plastic molded case.

**METRIC COARSE RANGE KIT** Covers smaller size range: 4x.7, 5x.8, 6x1.0, 8x1.25 and 10x1.5. **PART NO. 35003**

**METRIC COARSE RANGE KIT** Contains most popular metric sizes: 5x.8, 6x1.0, 8x1.25, 10x1.5 and 12x1.75. **PART NO. 35004**

**METRIC COARSE RANGE KIT W/14MM SPARK PLUG**  
Popular sizes for motorcycle and small engine sizes: 6x1.0, 8x1.25, 10x1.5, 12x1.75 plus 14x1.25 spark plug. **PART NO. 33005**

**METRIC FINE RANGE KIT** Popular sizes for tractor repair: 8x1.0, 10x1.0, 10x1.25, 12x1.25, 12x1.5. **PART NO. 37000**



## Spark Plug Thread Repair Kits

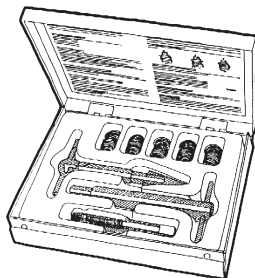

Each kit includes special pilot nose tap\*, installation-tang break-off tool, insert-extraction tool, a quantity of inserts and simple instructions in a sturdy steel case.

*Special pilot nose tap "reams" hole to the perfect size, ensuring a perfectly tapped hole every time!*

Size	Part No.	Inserts Per Kit	Drill . Size*
14x1.25	38140	10	9/16
18x1.5	38180	10	23/32

*\*Drilling is not required when using special tap supplied to repair stripped threads.*

## Individual Size Repair Kits Metric Sizes

Includes; High quality tap, Installation-tang break off tools, inserts, and simple instructions, in a steel box.



Size	Kit Part No.	Inserts Per Kit	Drill Size*
<b>COARSE PITCH</b>			
5x .8	35050	10	13/64"
6x1.0	35060	10	1/4"
7x1.0	35070	10	9/32"
8x1.25	35080	10	21/64"
10x1.5	35100	10	13/32"
12x1.75	35120	5	31/64"
14x2.0	35140	5	37/64"
<b>FINE PITCH</b>			
M8x1.0	37080	10	21/64"
M10x1.25	37100	10	13/32"
M12x1.5	37120	5	31/64"

*\*Drilling is normally not required when damaged threads have been fully stripped.*





# Metric Inserts

18-8 (T304) stainless steel inserts. Corrosion resistant. No pre-winding. *Interchangeable* with other helical systems. Stackable. Wide temperature tolerance (-270°F to +774°F). Meets current military (MS) and aircraft (AN) specifications. May be used in many materials such as steels, alloys, magnesium, plastics, and aluminum.

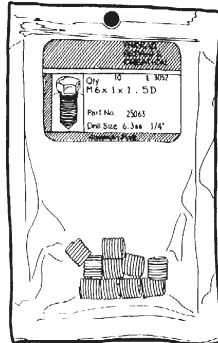

## Metric & Spark Plug Sizes

Insert Size	Insert Length	Part No.	Heli-Coil Cross-ref.	Pkg Qty
<b>COARSE PITCH</b>				
5-0.8	7.5mm	25053	R1084-5	10
6-1.0	9mm	25063	R1084-6	10
7-1.0	10.5mm	25073	R1084-7	10
8-1.25	12mm	25083	R1084-8	10
10-1.5	15mm	25103	R1084-10	10
12-1.75	18mm	25123	R1084-12	10
14-2.0	21mm	25143	R1084-14	5
<b>FINE PITCH</b>				
8-1.0	12mm	27083	R4255-8-10	10
10-1.0	15mm	28103	R4255-10	10
10-1.25	15mm	27103	R4649-10	10
12-1.5	18mm	27123	R4255-11-10	10
12-1.25	see spark plug sizes (below)			
14-1.5	21mm	27143	R3745-14	5
14-1.25	see spark plug sizes (below)			
16-1.5	24mm	27163	R3745-16	5
<b>SPARK PLUG SIZES</b>				
12-1.25	1/2"	28122	R482-1	10
12-1.25	3/4"	28123	R482-2	10
14-1.25	3/8"	28148	R512	10
14-1.25	1/2"	28149	R513-13	10
14-1.25	3/4"	28140	R513-10	10
18-1.5	1/2"	28189	R514-6	5

*Insertion tools and extractors available upon special request.*

VISIT OUR WEBSITE  
[mpi-online.com](http://mpi-online.com)  
 FAX ANYTIME!  
 219-696-6413



# Metric STI Taps

*(Screw Thread Insert Taps)*



## For use with Metric Recoil® Inserts

- Manufactured to the H limit requirements for Helical Style Inserts • Intermediate (Universal Plug) • HSS with ground threads • Interchangeable with HeliCoil STI Taps • All package: 1 each

Thread Size	Part No.	HeliCoil Cross-ref
<b>COARSE PITCH</b>		
5-0.8	45055	570-5
6-1.0	45065	570-6
7-1.0	45075	570-7
8-1.25	45085	570-8
10-1.5	45105	570-10
12-1.75	45125	2087-12
14-2.0	45145	2087-14
<b>FINE PITCH</b>		
8-1.0	47085	573-8
10-1.0	48105	573-10
10-1.25	47105	575-10
12-1.5	47125	4976-12
12-1.25	48125	-
14-1.25	48145	-
14-1.5	47145	4976-14
18-1.5	48185	-

*\* Available in taper, bottoming, pilot nose, spiral point, and spiral flute.*

**It is more  
 economical to buy  
 in unit or package  
 quantity.**

# E-Z LOK Thread Inserts

## Heavy Duty Carbon Steel Thread Inserts For Metal

**Will not back out or vibrate loose!**

Immediately on installation, micro-encapsulated Loctite® begins to set, and the newly installed insert can be fastened to within minutes. The adhesive continues to cure overnight until completely set. In addition, the adhesive seals against liquids and gases to pressures of 6,000 psi, and bonds to virtually all metals. E-Z Lok inserts are removable with standard screw extractors.

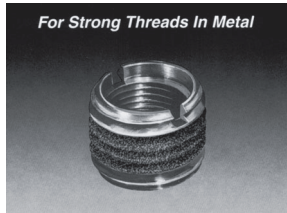

## NEW E-Z LOK THIN WALL INSERTS!

The same size as helical wire inserts, E-Z Lok Thin Wall Inserts give you all the advantages of traditional E-Z LOK inserts in a smaller diameter design!

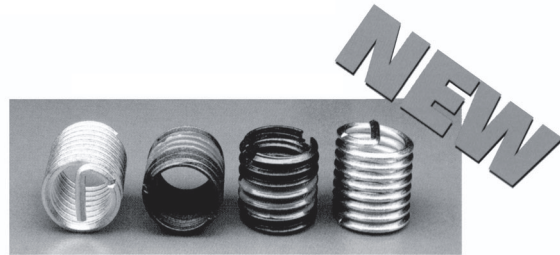

Solid construction Thin Wall E-Z Loks compared to same size wire type inserts. Both are 3/8-16size.

### COARSE THREAD

Internal Thread	External Thread*	Length	Part No.	Tap Drill Size	Pkg Qty
4-40	10-32	.250	329-004	5/32	10
6-32	1/4-20	.280	329-006	7	10
8-32	5/16-18	.290	329-008	F	10
10-24	3/8-16	.406	329-3	5/16	10
1/4-20	7/16-14	.437	329-4	23/64	10
5/16-18	1/2-13	.484	329-5	27/64	10
3/8-16	9/16-12	.515	329-6	31/64	10
7/16-14	5/8-11	.656	329-7	17/32	5
1/2-13	3/4-10	.656	329-8	21/32	5
9/16-12	3/4-10	.656	329-9	21/32	5
5/8-11	7/8-9	.687	329-10	49/64	5
3/4-10	1-8	.781	329-12	7/8	5
7/8-9	1-1/4-7	1.125	329-14	1-7/64	5
1-8	1-3/8-12	1.250	329-16	1-9/32	5

### THIN WALL INSERTS

10-24	5/16-18	.312	319-3	I	10
1/4-20	3/8-16	.375	319-4	Q	10
5/16-18	7/16-14	.437	319-5	X	10
3/8-16	1/2-13	.500	319-6	29/64	10
7/16-14	9/16-12	.560	319-7	33/64	5
1/2-13	5/8-11	.620	319-8	37/64	5

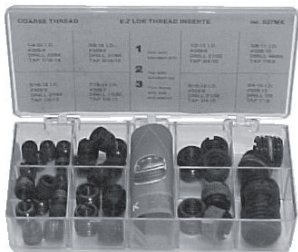

**E-Z LOK INSERT MAINTENANCE KIT**  
8 SIZES, 1/4-20 THRU 3/4-10 COARSE, TRADITIONAL E-Z LOKS IN A CLEAR STYRENE BOX. PART NO. 537MK

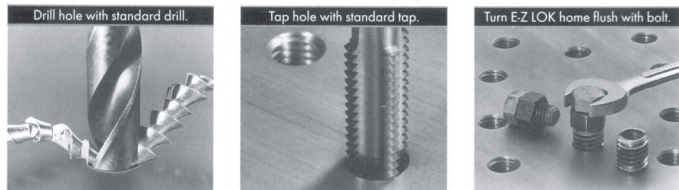

## Install with standard drills, taps & tools!

E-Z LOK external threads are standard size and pitch to permit use of standard drills and taps. No special tap sizes or installation tools are required!

### FINE THREAD

Internal Thread	External Thread*	Length	Part No.	Tap Drill Size	Pkg Qty
10-32	3/8-16	.406	329-332	5/16	10
1/4-28	7/16-14	.437	329-428	23/64	10
5/16-24	1/2-13	.484	329-524	27/64	10
3/8-24	9/16-12	.515	329-624	31/64	10
7/16-20	5/8-11	.656	329-720	17/32	5
1/2-20	3/4-10	.656	329-820	21/32	5
5/8-18	7/8-9	.687	329-10F	49/64	5
3/4-16	1-8	.781	329-1216	7/8	5
7/8-14	1-1/4-7	1.125	329-1414	1-7/64	5
1-14	1-3/8-12	1.250	329-1614	1-9/32	5

### THIN WALL INSERTS

10-32	5/16-18	.312	319-332	I	10
1/4-28	3/8-16	.375	319-428	Q	10
5/16-24	7/16-14	.437	319-524	X	10
3/8-24	1/2-13	.500	319-624	29/64	10
7/16-20	9/16-12	.560	319-720	33/64	5
1/2-20	5/8-11	.620	319-820	37/64	5

Ask for the E-Z LOK catalog with a complete line of heavy wall inserts, metric inserts, power drivers, stainless steel inserts, knife thread inserts for wood, knurled inserts for plastic and E-Z Lok assortments.

\*External thread listed is also tap size.



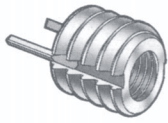

# Keensert® Thread Repair Inserts

Here's the easy way to repair stripped threads. Locking keys provide positive mechanical lock, preventing rotation due to vibration or torsion. Install Keensert® with standard drills and taps. No prewinder tool needed. Use in almost any material...aluminum, magnesium, cast iron, cold rolled steel, nylon and plastic. Easy to install and remove. Threads meet MIL-S-7742. AISI C1215 Carbon Steel or equivalent. Black parkerized finish.



Insert Part No.	Internal Thread Size	Wall Style	Tap Size (External Thread Size)	Insert Length	Insert* Pkg. Qty.	Drill Size	Professional Installation Tool
42-010	10-24 UNC	Thin wall	5/16-18	5/16"	4	I	42-032
42-011	10-32 UNF	Thin wall	5/16-18	5/16"	4	I	42-032
42-012	1/4-20 UNC	Thin wall	3/8-16	3/8"	4	Q	42-033
42-013	1/4-28 UNF	Thin wall	3/8-16	3/8"	4	Q	42-033
42-014	5/16-18 UNC	Thin wall	7/16-14	7/16"	4	X	42-034
42-015	5/16-24 UNF	Thin wall	7/16-14	7/16"	4	X	42-034
42-016	3/8-16 UNC	Thin wall	1/2-13	1/2"	3	29/64	42-035
42-017	3/8-24 UNF	Thin wall	1/2-13	1/2"	3	29/64	42-035
42-018	7/16-14 UNC	Thin wall	9/16-12	9/16"	3	33/64	42-036
42-019	7/16-20 UNF	Thin wall	9/16-12	9/16"	3	33/64	42-036
42-020	1/2-13 UNC	Thin wall	5/8-11	5/8"	2	37/64	42-037
42-021	1/2-20 UNF	Thin wall	5/8-11	5/8"	2	37/64	42-037
42-022	9/16-12 UNC	Heavy wall	3/4-16	13/16"	2	45/64	42-038
42-023	9/16-18 UNF	Heavy wall	3/4-16	13/16"	2	45/64	42-038
42-024	5/8-11 UNC	Heavy wall	7/8-14	7/8"	2	53/64	42-039
42-025	5/8-18 UNF	Heavy wall	7/8-14	7/8"	2	53/64	42-039
42-026	3/4-10 UNC	Heavy wall	1 1/8-12	1-1/8"	2	1-1/16	42-040
42-027	3/4-16 UNF	Heavy wall	1 1/8-12	1-1/8"	2	1-1/16	42-040
42-028	7/8-9 UNC	Heavy wall	1 1/4-12	1-1/4"	2	1-3/16	42-041
42-029	7/8-14 UNF	Heavy wall	1 1/4-12	1-1/4"	2	1-3/16	42-041
42-030	1-8 UNC	Heavy wall	1 3/8-12	1-3/8"	2	1-5/16	42-042
42-031	1-12 UNF	Heavy wall	1 3/8-12	1-3/8"	2	1-5/16	42-042

\*Package contains one Economy Drive Tool No. 42-043 (see below). Note: Inserts up to 1/4" bolt size have two locking keys, larger sizes have four locking keys. Custom Keensert assortments available upon request.

## ECONOMY DRIVE TOOL



Use to tap each individual key in place. Can be used with inserts up to 1/2" bolt size. Pkg. Qty. 5. **PART NO. 42-043**

## KEENSERT® INSTALLATION

**DRILL OUT OLD THREADS AND COUNTERSINK HOLE.**



1. Drill out old threads with a standard drill. Chamfer the hole with a 82° or 100° countersink.

**TAP NEW THREADS**

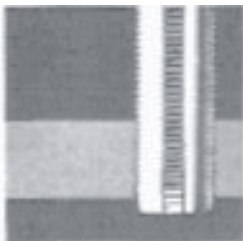

2. Tap new threads with a standard tap.

**SCREW IN KEENSERT**

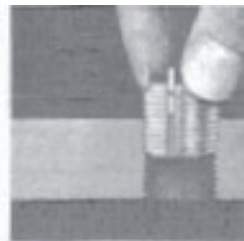

3. Screw in the insert until slightly below surface.

**DRIVE KEYS DOWN**

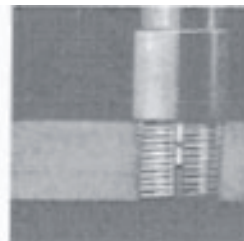

4. Drive keys down with several hammer taps on the installation tool

# Nutserts

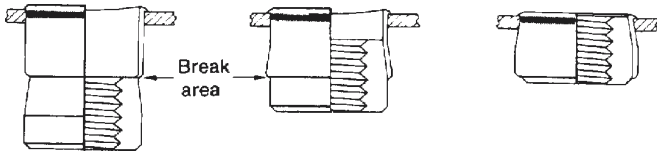

1. Nutsert in pre-drilled hole. 2. Base partially drawn into sleeve. 3. Fully installed.

An anchor/nut-type "blind" insert. Provides load bearing threads in sheet metal, steel castings, fiberglass, fiberboard, plastics and wood. Unique "Taper-Lock" feature; mandrel breaks the conical-shaped portion loose, drawing it up into the sleeve for a 360° contact fit. Can be installed in any material thickness from .030". Made of 1006-1010 Steel

STANDARD		
Part No.	Size	Qty
32003	6-32 UNC	50
32004	8-32 UNC	50
32005	10-24 (3/16) UNC	50
32006	10-32 (3/16) UNF	50
32007	1/4-20 UNC	50
32008	1/4-28 UNF	50
32009	5/16-18 UNC	25
32010	5/16-24 UNF	25
32011	3/8-16 UNC	25

METRIC		
Part No.	Size	Qty
32025	M4 x .7	50
32026	M5 x .8	50
32027	M6 x 1.0	25
32028	M8 x 1.25	25
32029	M10 x 1.50	25

## Nutsert Installation Tools



**NUTSERT TOOL**  
Installs nutserts and thin sheet nutserts (TSN). Includes hand tool and wrench. Conversion kits must be ordered separately.  
**PART NO. 32070**



**NUTSERT TOOL KIT**  
Includes hand tool, wrench and conversion kits for sizes 6-32, 8-32, 10-24, 1/4-20, 5/16-18, plus mandrel only for 10-32. Includes metal carrying case.  
**PART NO. 32071**

# Thin Sheet Nutserts

(TSN's)

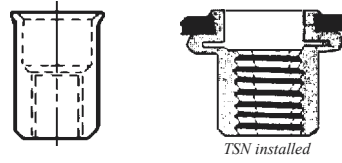

Threaded portion of insert is drawn towards tool, collapsing the unthreaded portion outward, causing a flange to form on the blind side of work. AISI 1010 Steel or Aluminum.

STANDARD			
Size	Steel	Alum.	Qty
6-32 UNC	32036	32046	50
8-32 UNC	32037	32047	50
10-24 (3/16) UNC	32038	32048	50
10-32 (3/16) UNF	32039	32049	50
1/4-20 UNC	32040	32050	50
5/16-18 UNC	32041	-	25

METRIC			
Size	Steel	Alum.	Qty
M4 x .7	32042	32053	50
M5 x .8	32043	32054	50
M6 x 1.0	32044	32055	25
M8 x 1.25	32045	32056	25

## Nutsert Conversion Kits



For use with 32070 Nutsert Tool.

STANDARD		
Part No.	Size	Qty
32057	6-32 UNC	1
32058	8-32 UNC	1
32059	10-24 UNC	1
32060	10-32 UNF	1
32061	1/4-20 UNC	1
32062	1/4-28 UNF	1
32063	5/16-18 UNC	1
32064	5/16-24 UNF	1
32065	3/8-16 UNC	1

METRIC		
Part No.	Size	Qty
32066	M4 x .7	1
32067	M5 x .8	1
32068	M6 x 1.0	1
32069	M8 x 1.25	1

# Jack Nuts®

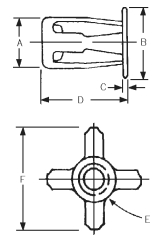
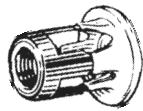

Used for mounting automotive mirrors, license plates, radiator brackets, voltage regulators, dome lights, luggage racks covers and supports. Use with thin, hollow wall or solid material. AISI 1010 Steel • Zinc Finish

Part No.	Unit Pkg	Thread (E)	Body Dia. (A)	Head Dia. (B)	Cap (C)	Over-all(D)	Grip Range(G)	Required Hole Dia.	Maximum Spread (F)**
03-236	25	6-32	.318	.468	.073	.653	1/64"-3/16"	.315-.330	.660
03-237	25	6-32	.318	.468	.073	.841	3/16"-3/8"	.315-.330	.720
03-238	25	10-24	.382	.531	.073	.716	1/64"-3/16"	.385-.400	.760
03-239	25	10-24	.382	.531	.073	.888	3/16"-3/8"	.385-.400	.820
03-240	25	1/4-20	.438	.625	.073	.731	1/64"-3/16"	.434-.450	.890
03-241	25	1/4-20	.438	.625	.073	.919	3/16"-3/8"	.434-.450	.890
03-242	25	1/4-20	Special purpose mirror mounting nut with rain-tight sealer (GM #367292)						

\*\*Spread varies with material thickness

## Jack Nut® Setting Tool



A much faster method of installing jack nuts. Great for high volume installations and tight corners. Use with common round head machine screws (not included) to anchor jack nuts in place. Quick release trigger. Cushion grip handles. **Part No. 10-497**

(Note: 10-497 is also used as a Hollow Wall Anchor installation tool. See page 38.)

## Jack Nut® Friction Wrench

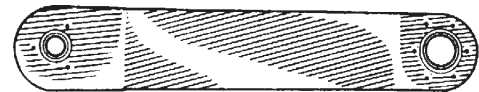

An inexpensive installation tool to keep nut from spinning in the hole. Insert wrench between the screw and the head of the fastener, hold wrench and run in screw to set Jack Nut. Pkg. 10 each. **Part No. 03-254**



# Well Nuts®

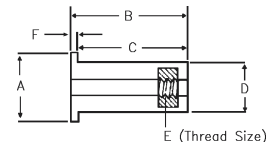

Used for mounting automotive mirrors, license plates, radiator brackets, voltage regulators, dome lights, luggage racks covers and supports. Use with thin, hollow wall or solid material. Made of neoprene with captive brass nut.

Part No.	Pkg Qty	Thread (E)	Head (A) Dia.	Overall Lgth(B)	Shank Length(C)	Shank Dia.(D)	Cap Thk(F)	Hole Size Required	For Wall Thickness
03-228	25	6-32	.452	.499	.437	.312	.062	5/16	.015 - .156
03-235	25	8-32	Special purpose OEM well nut for S10 pickups (GM #14048060)						
03-229	25	10-32	.500	.554	.518	.377	.036	3/8	.015 - .192
03-230	10	10-32	.562	1.05	1.000	.375	.051	3/8	.312 - .643
03-231	10	10-32	.562	.665	.625	.625	.377	3/8	.035 - .232
03-232	10	1/4-20	.740	.829	.642	.500	.187	1/2	.031 - .187
03-234	25	1/4-20	Special purpose OEM well nut for luggage racks (GM #528846, AMC #4003120)						
03-233	10	5/16-18	.875	.725	.600	.620	.125	5/8	.015 - .187

**MPI CAN BECOME YOUR SINGLE-SOURCE SUPPLIER ON MANY OF THE PARTS YOU CURRENTLY USE!**

# Regular Threaded Rod

(All-Thread or Ready Rod)



Use threaded rods for fast do-it-yourself special bolts, threaded studs, bent anchor bolts, hangers, hooks, tie-downs, clamps, etc. AISI 1008-1018 low carbon steel. Meets ASTM A307, A108 requirements. Hardness: Rb73. Tensile strength: 65,000 psi. minimum. Zinc finish.

## Coarse thread • Length: 36"

Part Number	Size	Pkg Qty
99-008	1/4-20	5
99-009	5/16-18	5
99-010	3/8-16	5
99-011	7/16-14	5
99-012	1/2-13	5
99-013	9/16-12	3
99-014	5/8-11	3
99-015	3/4-10	3
99-016	7/8-9	3
99-017	1"-8	3
99-018	1-1/8-7	1
99-019	1-1/4-7	1
99-020	1-1/2-6	1

## Fine thread • Length: 36"

Part Number	Size	Pkg Qty
99-021	1/4-28	5
99-022	5/16-24	5
99-023	3/8-24	5
99-024	7/16-20	5
99-025	1/2-20	5
99-026	9/16-18	3
99-027	5/8-18	3
99-028	3/4-16	3
99-029	7/8-14	3
99-030	1"-14	3
99-031	1-1/4-12	1

## Machine Screw Sizes • Length: 36"

Part Number	Size	Pkg Qty
99-003	6-32	10
99-004	8-32	10
99-005	10-24 (3/16 UNC)	10
99-006	10-32 (3/16 UNF)	10
99-007	12-24	10

## Coarse thread • Length: 72"

Part Number	Size	Pkg Qty
99-032	1/4-20	5
99-033	5/16-18	5
99-034	3/8-16	5
99-035	7/16-14	5
99-036	1/2-13	5
99-037	9/16-12	3
99-038	5/8-11	3
99-039	3/4-10	3
99-040	7/8-9	3
99-041	1"-8	3
99-042	1 1/8-7	1
99-043	1 1/4-7	1
99-044	1 1/2-6	1

Sizes not shown may be available on special request, subject to minimum packaging.



An American T-shirt maker in Miami printed shirts for the Spanish market which promoted the Pope's visit. Instead of "I saw the Pope" (el Papa), the shirts read "I Saw the Potato" (La papa).

# Alloy Steel Threaded Rod



Heat treated chromium-molybdenum steel, normally AISI 4140, meets ASTM-193 grade B7 material for high temperature service. 4142, or 4145 alloy steel. Use for high strength bolting or making threaded studs. Tensile strength: 125,000 psi. Hardness is RC 28-32. Rolled threads, not cut. Plain finish



Assortment In Stock!

## Coarse thread • Length: 36"

Part Number	Size	Pkg Qty
99-045	1/4-20	2
99-046	5/16-18	2
99-047	3/8-16	2
99-048	7/16-14	1
99-049	1/2-13	1
99-050	9/16-12	1
99-051	5/8-11	1
99-052	3/4-10	1
99-053	7/8-9	1
99-054	1"-8	1
99-055	1-1/8-7	1
99-056	1-1/4-7	1
99-057	1-1/2-6	1

## Fine thread • Length: 36"

Part Number	Size	Pkg Qty
99-058	1/4-28	1
99-059	5/16-24	1
99-060	3/8-24	1
99-061	7/16-20	1
99-062	1/2-20	1
99-063	5/8-18	1
99-064	3/4-16	1
99-065	7/8-14	1
99-066	1"-14	1
99-067	1-1/8-12	1
99-068	1-1/4-12	1

*Grade 5 or Grade 8 Hex Nuts recommended.  
Available in lengths up to 144" and larger diameters*

# Stainless Steel Threaded Rod



Type 304 stainless provides excellent corrosion resistance. Tensile strength: 70,000 psi. Nonmagnetic. Rolled threads.



Assortment In Stock!

## Coarse threads • Length: 36"

Part Number	Size	Pkg Qty
99-079	1/4-20	1
99-080	5/16-18	1
99-081	3/8-16	1
99-082	7/16-14	1
99-083	1/2-13	1
99-084	5/8-11	1
99-085	3/4-10	1
99-086	7/8-9	1
99-087	1"-8	1

## Fine Thread • Length: 36"

Part Number	Size	Pkg Qty
99-088	1/4-28	1
99-089	5/16-24	1
99-090	3/8-24	1
99-091	1/2-20	1

## Machine Screw Sizes • Length: 36"

Part Number	Size	Pkg Qty
99-075	6-32	1
99-076	8-32	1
99-077	10-24 (3/16 UNC)	1
99-078	10-32 (3/16 UNF)	1

*Also available in Type 316 Stainless Steel (subject to manufacturers package minimum).*

**CALL US IF YOU NEED AN ITEM  
YOU CAN'T FIND IN THIS CATALOG...  
WE STOCK MANY ITEMS  
THAT ARE NOT LISTED!**



# Rod Couplers

(Hex Coupling Nuts or Extension Nuts)

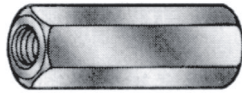

Fully threaded nuts used for joining two or more rods or studs. Also used for leveling feet, jig fixtures and spacing applications. Double chamfered. AISI 1010 - 1018 mild steel. Tensile strength: 60,000 psi. Coarse thread only. Zinc finish.

Part Number	Bolt Size	Length	W.A.F.†	Pkg Qty
03-320	10-24	3/4	5/16	50
03-321	1/4-20	7/8	3/8	50
03-322	5/16-18	1-3/4	5/8	25
03-323	3/8-16	1-3/4	5/8	25
03-324	7/16-14	1-3/4	5/8	25
03-325	1/2-13	1-3/4	11/16	25
03-326	5/8-11	2-1/8	13/16	15
03-327	3/4-10	2-1/4	1"	15
03-328	7/8-9	2-1/2	1-1/4	10
03-329	1"-8	2-1/2	1-1/4	10
03-330	1-1/8-7	3"	1-5/8	10
03-331	1-1/4-7	3"	1-5/8	10

† Width across flats or wrench size

# Brass Threaded Rod



Solid brass is 2/3 copper and 1/3 zinc. It's nonmagnetic, corrosion resistance and is highly conductive. Tensile strength: 55,000 psi. Coarse thread (unc) except where marked.



Length: 36"

Part Number	Size	Pkg Qty
99-153	6-32	1
99-154	8-32	1
99-155	10-24	1
99-156	10-32 (UNF)	1
99-157	1/4-20	1
99-158	5/16-18	1
99-159	3/8-16	1
99-160	7/16-14	1
99-161	1/2-13	1
99-162	5/8-11	1
99-163	3/4-10	1



# Metric Threaded Rod



DIN 975-8 Class 8.8 heat treated mild steel. Tensile strength: 113,000 psi. Ref. ISO 898/1 1978. Plain finish.

Coarse Pitch • Length: 1 meter†

Part Number	Thread Dia. x Pitch	Pkg Qty
99-113	M6 x 1.0	1
99-114	M8 x 1.25	1
99-115	M10 x 1.5	1
99-116	M12 x 1.75	1
99-117	M14 x 2.0	1
99-118	M16 x 2.0	1
99-119	M18 x 2.5	1
99-120	M20 x 2.5	1
99-121	M22 x 2.5	1
99-122	M24 x 3.0	1

† Approximately 39 inches or 3.28 ft.



# Left Hand Threaded Rod



Make custom left hand threaded bolts, studs or adjustment screws. AISI 1008 low carbon steel. 65,000 psi min. tensile strength. Plain finish.

Coarse Threads • Length: 36"

Part Number	Size	Pkg Qty
99-164	6-32	1
99-165	8-32	1
99-166	10-24	1
99-167	12-24	1
99-168	1/4-20	1
99-169	5/16-18	1
99-170	3/8-16	1
99-171	7/16-14	1
99-172	1/2-13	1
99-173	9/16-12	1
99-174	5/8-11	1
99-175	3/4-10	1
99-176	7/8-9	1
99-177	1"-8	1

# Acme Threaded Rod & Nuts

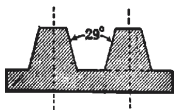

The acme thread has a 29° included angle that provides quicker threading than standard "V" shaped threads.

## Acme Threaded Rod

Use anywhere frequent assembly and disassembly where dirt and contaminants are a problem. Holding and adjusting concrete forms, screw presses, vise screws, valves, lifts, scaffold leveling screws, clamps and jacks. AISI 1008-1018 low carbon steel. Right-hand thread. Plain finish†.

Part Number	Size	Pkg Qty
99-123	1/2-10 x 3'	1
99-124	5/8-8 x 3'	1
99-125	3/4-6 x 3'	1
99-127	1"-5 x 3'	1

## Acme Thread Hex Nuts

Use in conjunction with acme rod. Provides smooth linear motion. Made from low carbon steel. Right-hand thread. Plain finish‡.

Part Number	Size	Pkg Qty
03-260	1/2-10	1
03-261	5/8-8	1
03-262	3/4-6	1
03-264	1"-5	1

† Also available in left hand thread, brass, alloy steel, nylon and stainless steel ‡ Acme thread rod couplers, round nuts, square nuts, wing nuts and flange nuts also available, subject to manufacturers' package minimum.

# Water-Hardened Drill Rod



Assortment In Stock!

Water quenching drill rod heat treats evenly and provides toughness and maximum wear resistance. Ideal for maintenance use even without heat-treating. Use this round stock for machining tools, dies, dowels, keys, tabs, arbors, special threaded rods, roller bearings, mandrels, punches, pinions, knock-out pins, pins, etc.. Ground and polished to a surface finish of better than 40 micro inches. Supplied in annealed condition. Ready for machining and heat-treating. Plain finish.

### Tolerances

1/16" - 1/8"; +/- .0003"  
 1/8" - 7/16"; +/- .0005"  
 1/2" TO 2"; +/- .001"

Length: 36"

Part Number	Diameter	Pkg Qty
99-100	1/16	5
99-101	1/8	5
99-102	5/32	5
99-103	3/16	5
99-104	7/32	5
99-105	1/4	5
99-106	5/16	5
99-107	3/8	3
99-108	7/16	3
99-109	1/2	2
99-110	5/8	2
99-111	3/4	2

Available in smaller, larger, and intermediate diameters, letter sizes A to Z, , number sizes 1-52, and oil hardened.

*Colgate introduced a toothpaste in France called "Cue", which also just happened to be the name of a notorious national porno magazine.*



# Forming Rod



Assortment  
in Stock!

Round bar is cold-drawn C-1010, except 7/8" and 1" diameter which are hot rolled C-1025 carbon steel. Zinc finish.

Length: 36"

Part Number	Diameter	Pkg Qty
99-143	3/16	5
99-144	1/4	5
99-145	5/16	5
99-146	3/8	5
99-147	7/16	3
99-148	1/2	3
99-149	5/8	3
99-150	3/4	3
99-151	7/8	2
99-152	1"	2

*Also available in stainless steel, brass and long lengths.*

# Threaded Rod Rack

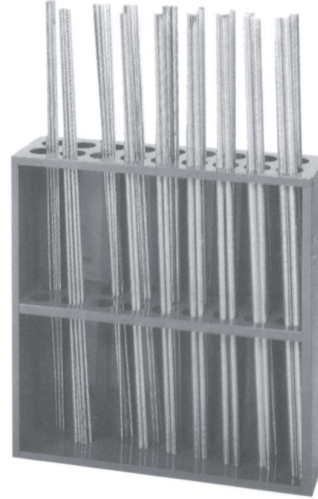

(Threaded rod not included)

Displays, organizes and protects up to 6 ft long threaded rod, round bar and many other materials. Has eighteen 2-1/16" diameter openings. Measures 24-1/8"W x 24"H x 6-7/8"D. Heavy gauge cold rolled steel. Interlocking design. Color is gray. **Part no. 99-112**

# E-Z LOK® THREAD INSERTS



**Ask for a free catalog!**

New E-Z LOK Thinwall Inserts on page 48!



**The Doctor is in!**

See page 338



# Slotted Steel Machine Screws

Deep slots and clean, sharp threads. Flat and oval head screws have 82° angles.  
Bright zinc finish. 1018 low carbon steel. Pkg: 100 each

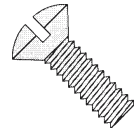
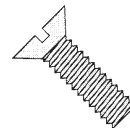
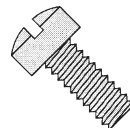
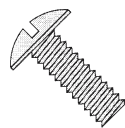
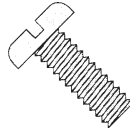
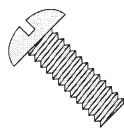
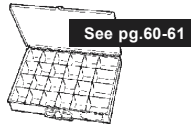

Size	Round Part No.	Pan Part No.	Truss Part No.	Fillister Part No.	Flat Part No.	Oval Part No.
2-56 x 1/4	25-000	-	-	-	25-151	-
2-56 x 3/8	25-001	-	-	-	25-152	-
2-56 x 1/2	25-002	-	-	-	25-400	-
2-56 x 3/4	25-003	-	-	-	-	-
3-48 x 3/16	-	-	-	-	25-153	-
3-48 x 1/4	25-004	-	-	-	25-154	-
3-48 x 3/8	25-005	-	-	-	25-155	-
3-48 x 1/2	25-006	-	-	-	25-156	-
3-48 x 3/4	25-007	-	-	-	-	-
4-40 x 3/16	25-276	-	-	-	-	-
4-40 x 1/4	25-008	25-280	-	-	25-157	-
4-40 x 3/8	25-009	25-281	-	-	25-158	-
4-40 x 1/2	25-010	25-282	-	-	25-159	-
4-40 x 3/4	25-011	-	-	-	25-160	-
4-40 x 1"	25-012	-	-	-	25-161	-
4-40 x 1-1/4	25-013	-	-	-	-	-
4-40 x 1-1/2	25-014	-	-	-	-	-
5-40 x 3/16	25-015	-	-	-	-	-
5-40 x 1/4	25-016	25-404	-	-	25-401	-
5-40 x 3/8	25-017	25-405	-	-	25-162	-
5-40 x 1/2	25-018	25-283	-	-	25-163	-
5-40 x 3/4	25-020	25-284	-	-	25-164	-
5-40 x 1"	25-021	-	-	-	25-165	-
5-40 x 1-1/4	25-390	-	-	-	-	-
5-40 x 1-1/2	25-391	-	-	-	-	-
5-40 x 2"	25-392	-	-	-	-	-
6-32 x 3/16	-	-	-	-	25-166	-
6-32 x 1/4	25-022	25-285	-	25-412	25-167	-
6-32 x 5/16	-	-	-	25-361	-	-
6-32 x 3/8	25-023	25-286	25-333	25-362	25-168	25-310
6-32 x 1/2	25-024	25-287	25-334	25-363	25-169	25-311
6-32 x 5/8	25-025	25-288	-	25-413	25-170	-
6-32 x 3/4	25-026	25-289	25-335	25-414	25-171	25-312
6-32 x 7/8	25-027	-	-	-	-	-
6-32 x 1"	25-028	25-290	25-336	25-415	25-172	25-313
6-32 x 1-1/4	25-029	-	-	25-416	25-173	25-314
6-32 x 1-1/2	25-030	-	-	25-417	25-174	-
6-32 x 1-3/4	25-031	-	-	-	25-175	-
6-32 x 2"	25-032	-	-	25-418	25-176	-
6-32 x 2-1/2	25-033	-	-	-	25-177	-
6-32 x 3"	25-034	-	-	-	25-178	-
6-32 x 4"	25-035	-	-	-	25-179	-
6-32 x 6"	25-036	-	-	-	-	-

(Continued next page)

**SAVE TIME BY LETTING US LOCATE THOSE HARD-TO-FIND ITEMS FOR YOU!**



# Slotted Steel Machine Screws

Deep slots and clean, sharp threads. Flat and oval head screws have 82° angles.  
Bright zinc finish. 1018 low carbon steel. Pkg: 100 each

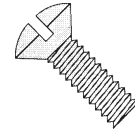
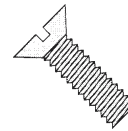
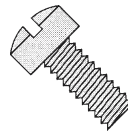
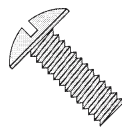
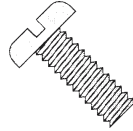
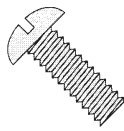

Size	Round Hd. Part No.	Pan Hd. Part No.	Truss Hd. Part No.	Fillister Hd. Part No.	Flat Hd. Part No.	Oval Hd. Part No.
8-32 x 1/4	25-038	-	-	25-364	25-181	-
8-32 x 5/16	25-039	-	-	-	-	-
8-32 x 3/8	25-040	25-406	25-408	25-365	25-182	25-315
8-32 x 1/2	25-041	25-291	25-337	25-366	25-183	25-316
8-32 x 5/8	25-042	25-292	-	25-419	25-184	-
8-32 x 3/4	25-043	25-293	25-338	25-367	25-185	25-317
8-32 x 1"	25-044	25-294	25-339	25-368	25-186	25-318
8-32 x 1-1/4	25-045	-	25-340	25-369	25-187	25-319
8-32 x 1-1/2	25-046	-	-	25-370	25-188	-
8-32 x 1-3/4	25-047	-	-	-	25-189	-
8-32 x 2"	25-048	-	-	-	25-190	-
8-32 x 2-1/4	25-049	-	-	-	-	-
8-32 x 2-1/2	25-050	-	-	-	25-191	-
8-32 x 3"	25-051	-	-	-	25-192	-
8-32 x 3-1/2	25-052	-	-	-	-	-
8-32 x 4"	25-053	-	-	-	-	-
8-32 x 4-1/2	25-054	-	-	-	-	-
8-32 x 5"	25-055	-	-	-	-	-
10-24 x 1/4	25-056	-	25-409	-	25-193	-
10-24 x 3/8	25-057	25-407	25-410	25-420	25-194	25-320
10-24 x 1/2	25-058	25-295	25-341	25-421	25-195	25-321
10-24 x 5/8	25-059	-	-	25-422	25-196	-
10-24 x 3/4	25-060	25-296	25-342	25-423	25-197	25-322
10-24 x 1"	25-061	25-297	25-343	25-424	25-199	25-323
10-24 x 1-1/4	25-062	25-298	25-344	25-425	25-200	-
10-24 x 1-1/2	25-063	-	25-345	25-426	25-201	25-324
10-24 x 1-3/4	25-064	-	-	-	25-202	-
10-24 x 2"	25-065	-	-	25-427	25-203	-
10-24 x 2-1/4	25-066	-	-	-	25-204	-
10-24 x 2-1/2	25-067	-	-	-	25-205	-
10-24 x 3"	25-068	-	-	-	25-206	-
10-24 x 3-1/2	25-069	-	-	-	-	-
10-24 x 4"	25-070	-	-	-	25-207	-
10-24 x 5"	25-071	-	-	-	25-208	-
10-24 x 6"	25-072	-	-	-	25-209	-
10-32 x 1/4	25-073	25-299	25-346	-	25-210	-
10-32 x 3/8	25-074	25-300	25-347	25-428	25-211	-
10-32 x 1/2	25-075	25-301	25-348	25-371	25-212	25-403
10-32 x 5/8	25-076	-	-	25-429	-	-
10-32 x 3/4	25-077	25-302	25-349	25-430	25-213	25-325
10-32 x 1"	25-078	25-303	25-350	25-431	25-214	25-326
10-32 x 1-1/4	25-079	-	-	25-432	25-215	-
10-32 x 1-1/2	25-080	-	-	25-433	25-216	-
10-32 x 1-3/4	25-081	-	-	-	25-217	-
10-32 x 2"	25-082	-	-	25-372	25-218	-
10-32 x 2-1/2	25-083	-	-	-	25-219	-
10-32 x 3"	25-084	-	-	-	-	-
10-32 x 3-1/2	25-085	-	-	-	-	-

(Continued next page)

# Slotted Steel Machine Screws

Deep slots and clean, sharp threads. Flat and oval head screws have 82° angles.  
Bright zinc finish. 1018 low carbon steel. Pkg: 100 each

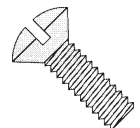
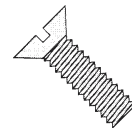
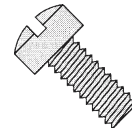
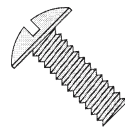
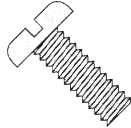
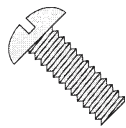
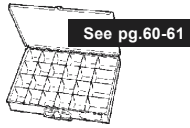

Size	Round Hd. Part No.	Pan Hd. Part No.	Truss Hd. Part No.	Fillister Hd. Part No.	Flat Hd. Part No.	Oval Hd. Part No.
10-32 x 4"	25-086	-	-	-	-	-
10-32 x 4-1/2"	25-087	-	-	-	-	-
10-32 x 5"	25-088	-	-	-	-	-
10-32 x 5-1/2"	25-089	-	-	-	-	-
10-32 x 6"	25-090	-	-	-	-	-
12-24 x 1/4"	25-091	-	-	-	-	-
12-24 x 3/8"	25-092	-	-	-	-	-
12-24 x 1/2"	25-093	-	-	-	25-221	-
12-24 x 5/8"	25-094	-	-	-	-	-
12-24 x 3/4"	25-095	-	-	-	25-222	-
12-24 x 1"	25-096	25-304	-	-	25-223	-
12-24 x 1-1/4"	25-097	-	-	-	25-224	-
12-24 x 1-1/2"	25-098	-	-	-	25-225	-
12-24 x 1-3/4"	25-099	-	-	-	-	-
12-24 x 2"	25-100	-	-	-	25-226	-
12-24 x 3"	25-102	-	-	-	25-402	-
1/4-20 x 1/4"	25-103	-	-	-	-	-
1/4-20 x 5/16"	-	-	-	-	25-227	-
1/4-20 x 3/8"	25-104	25-306	-	-	25-228	-
1/4-20 x 1/2"	25-105	25-307	25-411	25-373	25-229	25-327
1/4-20 x 5/8"	25-106	-	-	25-434	25-230	-
1/4-20 x 3/4"	25-107	25-308	25-351	25-435	25-231	25-328
1/4-20 x 1"	25-108	25-309	25-352	25-436	25-232	25-329
1/4-20 x 1-1/4"	25-109	-	-	25-437	25-233	25-330
1/4-20 x 1-1/2"	25-110	-	25-353	25-374	25-234	25-331
1/4-20 x 1-3/4"	25-111	-	-	-	25-235	-
1/4-20 x 2"	25-112	-	-	25-375	25-236	25-332
1/4-20 x 2-1/4"	25-113	-	-	-	-	-
1/4-20 x 2-1/2"	25-114	-	-	25-376	25-237	-
1/4-20 x 2-3/4"	25-115	-	-	-	-	-
1/4-20 x 3"	25-116	-	-	-	25-238	-
1/4-20 x 3-1/4"	25-117	-	-	-	-	-
1/4-20 x 3-1/2"	25-118	-	-	-	25-239	-
1/4-20 x 4"	25-119	-	-	-	25-240	-
1/4-20 x 4-1/2"	25-120	-	-	-	-	-
1/4-20 x 5"	25-121	-	-	-	25-241	-
1/4-20 x 5-1/2"	25-122	-	-	-	-	-
1/4-20 x 6"	25-123	-	-	-	25-242	-
1/4-20 x 7"	25-124	-	-	-	-	-
5/16-18 x 3/8"	25-125	-	-	-	-	-
5/16-18 x 1/2"	25-126	-	25-354	-	25-243	-
5/16-18 x 5/8"	-	-	-	25-377	25-244	-
5/16-18 x 3/4"	25-127	-	25-355	-	25-245	-
5/16-18 x 1"	25-128	-	25-356	-	25-246	-
5/16-18 x 1-1/4"	25-129	-	25-357	25-378	25-247	-
5/16-18 x 1-1/2"	25-130	-	25-358	-	25-248	-
5/16-18 x 1-3/4"	25-131	-	-	-	25-249	-
5/16-18 x 2"	25-132	-	-	-	25-250	-

(Continued next page)



# Slotted Steel Machine Screws

Deep slots and clean, sharp threads. Flat and oval head screws have 82° angles.  
Bright zinc finish. 1018 low carbon steel.

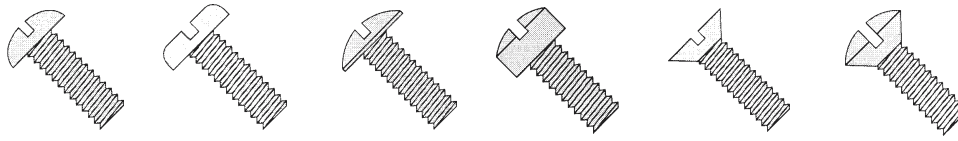

Diameter	Round Hd. Part No.	Pan Hd. Part No.	Truss Hd. Part No.	Fillister Hd. Part No.	Flat Hd. Part No.	Oval Hd. Part No..	Pkg Qty
5/16-18 x 2-1/2	25-133	-	-	-	25-251	-	100
5/16-18 x 3"	25-134	-	-	-	25-252	-	100
5/16-18 x 3-1/2	25-135	-	-	-	-	-	100
5/16-18 x 4"	25-136	-	-	-	25-253	-	100
5/16-18 x 5"	25-137	-	-	-	25-254	-	50
5/16-18 x 6"	25-138	-	-	-	25-255	-	50
3/8-16 x 1/2	25-139	-	-	-	25-256	-	100
3/8-16 x 3/4	25-140	-	-	-	25-257	-	100
3/8-16 x 1"	25-141	-	-	-	25-258	-	100
3/8-16 x 1-1/4	25-142	-	-	-	25-259	-	100
3/8-16 x 1-1/2	25-143	-	-	-	25-260	-	100
3/8-16 x 1-3/4	25-144	-	-	-	25-261	-	100
3/8-16 x 2"	25-145	-	-	-	25-262	-	100
3/8-16 x 2-1/2	25-146	-	-	-	25-263	-	50
3/8-16 x 3"	25-147	-	-	-	25-264	-	50
3/8-16 x 4"	25-148	-	-	-	25-265	-	50
3/8-16 x 5"	25-149	-	-	-	25-266	-	50
3/8-16 x 6"	25-150	-	-	-	25-267	-	50
1/2-13 x 3/4	-	-	-	-	25-268	-	100
1/2-13 x 1"	25-393	-	-	-	25-269	-	100
1/2-13 x 1-1/4	25-394	-	-	-	25-270	-	100
1/2-13 x 1-1/2	25-395	-	-	-	25-271	-	100
1/2-13 x 1-3/4	25-396	-	-	-	25-272	-	100
1/2-13 x 2"	25-397	-	-	-	25-273	-	50
1/2-13 x 2-1/2	25-398	-	-	-	25-274	-	50
1/2-13 x 3"	25-399	-	-	-	25-275	-	50

(Flat and oval heads have 82° angles.)



**ROUND HD. SLTD. MACHINE SCREW MAINTENANCE KIT**  
12 SIZES, #6-32, #8-32 AND #10-24, UP TO 1" LG. WITH HEX MS NUTS IN A CLEAR POLYSTYRENE BOX. **PART NO. 502MK**

**ROUND HD. SLTD. MACHINE SCREW MAINTENANCE KIT**  
18 SIZES, #6 - 1/4" DIA. (COARSE) PLUS 10-32 (FINE) UP TO 1" LG. WITH HEX MS NUTS IN A CLEAR POLYSTYRENE BOX. **PART NO. 503MK**

**ROUND HD. SLTD. MACHINE SCREW MAINTENANCE KIT**  
12 SIZES, #10-32, #12-24, 1/4-20 DIA. UP TO 1 1/2" LG. WITH HEX MS NUTS IN A CLEAR POLYSTYRENE BOX. **PART NO. 504MK**

SERVICE IS OUR PRIORITY! OUR COMMITMENT IS TO MEET YOUR NEEDS!

# Machine Screw Assortments



**RD. HD. SLTD. MACHINE SCREW ASSORTMENT**  
24 SIZES, #6-1/4" DIA. UP TO 1 1/2" LG. WITH NUTS IN A  
LARGE STEEL DRAWER. **PART NO. 16-1524**

**RD. HD. SLTD. MACHINE SCREW ASSORTMENT**  
24 SIZES, #6-#12 DIA. UP TO 1 1/2" LG. WITH NUTS, IN A  
LARGE STEEL DRAWER. **PART NO. 16-1624**

**RD. HD. SLTD. MACHINE SCREW ASSORTMENT**  
24 SIZES, #6-1/4" DIA. UP TO 2" LG. WITH NUTS, IN A  
LARGE STEEL DRAWER. **PART NO. 16-1724**



**FLAT HD. SLTD. MACHINE SCREW ASSORTMENT**  
24 SIZES, #6-1/4" DIA. UP TO 1 1/2" LG. WITH NUTS IN A  
LARGE STEEL DRAWER. **PART NO. 16-1824**



**PAN HEAD PHILLIPS MACHINE SCREW ASSORTMENT**  
24 SIZES, #6-1/4" DIA. UP TO 1 1/2" LG. WITH NUTS IN A LARGE  
STEEL DRAWER. **PART NO. 16-3924**

# Hex Trim Screws

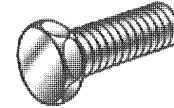

The preferred design for high-volume assembly work, where pneumatic equipment is used to drive the screw. Made of low carbon steel. Zinc finish.

Size	Part No.	Pkg Qty
8-32 x 1/2	25-379	100
8-32 x 3/4	25-380	100
8-32 x 1"	25-381	100
10-24 x 1/2	25-382	100
10-24 x 3/4	25-383	100
10-24 x 1"	25-384	100
10-32 x 1/4	25-385	100
10-32 x 1/2	25-386	100
10-32 x 3/4	25-387	100
10-32 x 1"	25-388	100
10-32 x 1-1/4	25-389	100

*Length measured from under head.*

Note: Stocked in several styles including indented, slotted, washer type or any combination of those head styles. Regretfully, we cannot guarantee shipment of any specific head style.

# Drive Screws

*(Thread Forming Screws or Drive Rivets)*



For permanent fastening in metals and plastics. Must be forced under pressure or tapped in hole with a hammer. This is a relatively tamperproof fastener designed for sheet metal, castings and motor housings with predrilled or punched holes. AISI 1016-1024 hardened steel. Round head ASA Type U. Hardness: RC 45. Zinc finish. Pkg. 100 each.

Size	Part No.	Drill Size
4 x 1/4	24-700	37
4 x 3/8	24-701	37
6 x 1/4	24-702	31
6 x 3/8	24-703	31



# Phillips Steel Machine Screws

Deep recess and clean, sharp threads. Flat and oval head screws have 82° angles.  
Bright zinc finish. 1018 low carbon steel. Pkg: 100 each



See pg.61

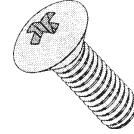
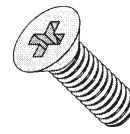
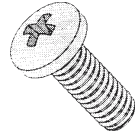
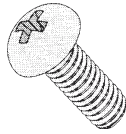

Size	Round Head Part No.	Pan Head Part No.	Flat Head Part No.	Oval Head Part No.
6-32 x 1/4	-	24-731	24-762	-
6-32 x 3/8	-	24-732	24-763	24-972
6-32 x 1/2	24-961	24-733	24-764	24-973
6-32 x 3/4	24-962	24-734	24-765	24-974
6-32 x 1"	-	24-735	24-766	24-975
6-32 x 1-1/4	-	24-1001	-	24-976
6-32 x 1-1/2	-	24-1002	-	24-977
8-32 x 1/4	-	24-736	24-767	-
8-32 x 3/8	-	24-737	24-768	24-978
8-32 x 1/2	24-963	24-738	24-769	24-979
8-32 x 3/4	24-964	24-739	24-770	24-980
8-32 x 1"	24-965	24-740	24-771	24-981
8-32 x 1-1/4	-	24-741	24-772	24-982
8-32 x 1-1/2	-	24-742	24-773	24-983
10-24 x 3/8	-	24-743	24-774	24-984
10-24 x 1/2	24-966	24-744	24-775	24-985
10-24 x 3/4	24-967	24-745	24-776	24-986
10-24 x 1"	24-968	24-746	24-777	24-987
10-24 x 1-1/4	-	24-747	24-778	24-988
10-24 x 1-1/2	-	24-748	24-779	24-989
10-32 x 3/8	-	24-749	24-780	24-990
10-32 x 1/2	24-969	24-750	24-781	24-991
10-32 x 3/4	24-970	24-751	24-782	24-992
10-32 x 1"	24-971	24-752	24-783	24-993
10-32 x 1-1/4	-	24-753	24-784	24-994
10-32 x 1-1/2	-	24-754	24-785	24-995
1/4-20 x 3/8	-	24-755	-	-
1/4-20 x 1/2	-	24-756	24-786	24-996
1/4-20 x 3/4	-	24-757	24-787	24-997
1/4-20 x 1"	-	24-758	24-788	24-998
1/4-20 x 1-1/4	-	24-759	24-789	24-999
1/4-20 x 1-1/2	-	24-760	24-790	24-1000
1/4-20 x 2"	-	24-761	24-791	-



**PAN HEAD PHILLIPS  
MACHINE SCREW ASSORTMENT**  
24 SIZES, #6-1/4" DIA. UP TO 1 1/2" LG.  
WITH NUTS IN A LARGE STEEL  
DRAWER. PART NO. 16-3924

# Thumb Screws

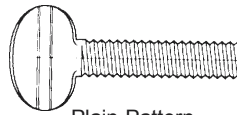

Plain Pattern

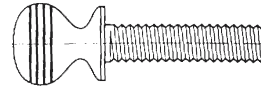

Shoulder Pattern

Cold headed one piece screw used where the fastener is frequently adjusted manually (without driver or wrench). Shoulder pattern type allows flush seating with mating surface, avoids over-tightening and stripped threads. Tensile strength: 48,000 psi minimum. Made from low carbon steel. Zinc finish

Size	PART NUMBER		Pkg Qty
	Plain Pattern	Shoulder Pattern	
6-32 x 1/2	25-483	25-509	100
6-32 x 3/4	25-484	25-510	100
6-32 x 1"	25-485	-	100
8-32 x 1/2	25-462	25-511	100
8-32 x 3/4	25-486	25-512	100
8-32 x 1"	25-463	-	100
10-24 x 1/2	25-487	25-513	100
10-24 x 3/4	25-488	25-514	100
10-24 x 1"	25-464	25-465	100
10-24 x 1-1/2	25-466	-	50
10-24 x 2"	25-489	-	50
10-32 x 1/2	25-490	25-515	100
10-32 x 3/4	25-491	25-516	100
10-32 x 1"	25-492	25-517	100
10-32 x 1-1/2	25-493	-	50
1/4-20 x 3/8	25-495	-	50
1/4-20 x 1/2	25-467	25-519	50
1/4-20 x 3/4	25-496	25-520	50
1/4-20 x 1"	25-468	25-521	50
1/4-20 x 1-1/4	25-469	-	50
1/4-20 x 1-1/2	25-497	25-470	50
1/4-20 x 2"	25-471	-	50
1/4-20 x 2-1/2	25-472	25-473	25
5/16-18 x 1/2	25-498	25-522	50
5/16-18 x 3/4	25-474	25-523	50
5/16-18 x 1"	25-499	25-475	50
5/16-18 x 1-1/4	25-500	-	50
5/16-18 x 1-1/2	25-476	25-524	50
5/16-18 x 2"	25-501	25-477	25
5/16-18 x 2-1/2	25-502	-	25
5/16-18 x 3"	25-503	-	25
3/8-16 x 3/4	25-504	25-525	25
3/8-16 x 1"	25-505	25-478	25
3/8-16 x 1-1/4	25-506	-	25
3/8-16 x 1-1/2	25-480	25-479	25
3/8-16 x 2"	25-507	25-481	25
3/8-16 x 2-1/2	25-482	-	25
3/8-16 x 3"	25-508	-	25



# Floorboard Screws

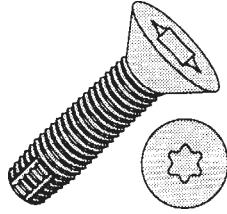

## Torx® Drive Floorboard Screws

Flat head, type-F self tapping screws with genuine Torx® drive for positive torque. Eliminates cam out and other drive problems. Increases efficiency and reduces fastening costs. 82° countersunk head. Black phosphate finish. Pkg. Qty. 100 each.

Part No.	Size	Drive Size	Suggested Drill Size
24-397 ...	1/4-20 x 1-1/2	T30	#2
24-398 ...	1/4-20 x 2	T30	#2
24-399 ...	1/4-20 x 2-1/2	T30	#2
24-400 ...	1/4-20 x 3	T30	#2
24-402 ...	1/4-20 x 3-1/2	T30	#2
24-403 ...	5/16-18 x 2-1/2	T40	K
24-404 ...	5/16-18 x 3	T40	K

*Length measured overall.*

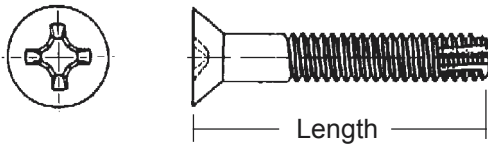

## Phillips Floorboard Screws

Type "F" Point. Zinc finish. Pkg. Qty. 100 each.

Part No.	Size	Drive Size	Drill Size
24-393 ...	1/4-20 x 2"	#3	#2
24-394 ...	1/4-20 x 2-1/2	#3	#2

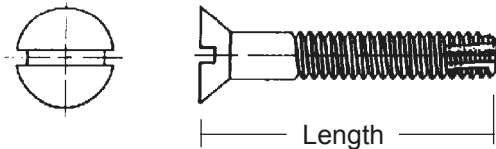

## Slotted Floorboard Screws

Type "F" Point. Zinc finish. Pkg. Qty. 100 each.

Part No.	Size	Blade Thickness	Drill Size
24-395 ...	1/4-20 x 2-1/2	.055"	#2
24-396 ...	1/4-20 x 3"	.055"	#2

# Header-Tek Screws

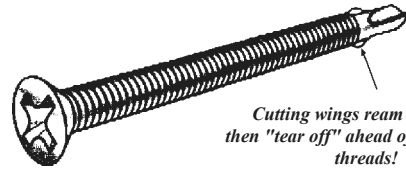

*Cutting wings ream the wood, then "tear off" ahead of self-tapping threads!*

Self-drills up to 1/4" thick steel. Designed for wood to steel header installations. 82° countersunk head. Phillips flat head. Zinc finish. Pkg. Qty. 100 each.

Part No.	Size	Drive Size
24-405 .....	12-24 x 2"	#3
24-401 .....	1/4-20 x 2-3/4"	#3

*Length measured overall.*

## Insert Bits

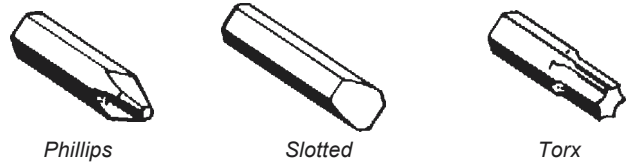

Hex size: 1/4". Overall length: 1"

Part No.	Style	For Screws	Point Size	Pkg Qty
6725 .....	Phillips	12-1/4	#3	10
6737 .....	Slotted	1/4	.055"Thk	10
6720A .....	Torx	1/4	T30	10
6721 .....	Torx	5/16	T40	10

## Magnetic Insert Bit Holder

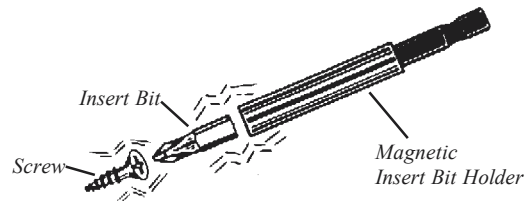

Made from stainless steel. Pkg: 10 each

Part No.	Hex Opening	Hex Shank	O.A. Length
6767A .....	1/4"	1/4"	3"



# Type-F Thread Cutting Screws

For use in heavy gauge sheet metal, aluminum, cast iron, brass and plastic. Type "F" point cuts own threads in predrilled hole. AISI 1016 - 1024 hardened steel. Hardness: Rc38. Zinc finish.



Size	Pan Slotted Part No.	Hex Washer Hd.† Part No.	Pkg Qty	Drill Size Required
6-32 x 1/4	24-338	-	100	#34
6-32 x 3/8	24-339	-	100	#34
6-32 x 1/2	24-340	24-358	100	#34
6-32 x 3/4	24-341	24-359	100	#34
6-32 x 1"	24-342	24-483	100	#34
8-32 x 1/4	24-343	-	100	9/64"
8-32 x 3/8	24-344	24-360	100	9/64"
8-32 x 1/2	24-345	24-361	100	9/64"
8-32 x 3/4	24-346	24-363	100	9/64"
8-32 x 1"	-	24-364	100	9/64"
10-24 x 3/8	24-348	24-366	100	5/32"
10-24 x 1/2	24-349	24-367	100	5/32"
10-24 x 5/8	-	24-368	100	5/32"
10-24 x 3/4	24-350	24-369	100	5/32"
10-24 x 1"	24-351	24-370	100	5/32"
12-24 x 1/2	-	24-372	100	3/16"
12-24 x 3/4	-	24-373	100	3/16"
12-24 x 1"	-	24-374	100	3/16"
1/4-20 x 3/8	-	24-376	100	7/32"
1/4-20 x 1/2	24-352	24-377	100	7/32"
1/4-20 x 5/8	24-353	24-378	100	7/32"
1/4-20 x 3/4	24-354	24-379	100	7/32"
1/4-20 x 1"	24-355	24-381	100	7/32"
1/4-20 x 1-1/4	-	24-382	100	7/32"
5/16-18 x 1/2	-	24-384	100	I
5/16-18 x 3/4	-	24-385	100	I
5/16-18 x 1"	-	24-386	100	I
5/16-18 x 1-1/4	-	24-387	100	I
3/8-16 x 3/4	-	24-389	50	21/64"
3/8-16 x 1"	-	24-390	50	21/64"
3/8-16 x 1-1/4	-	24-391	25	21/64"
3/8-16 x 1-1/2	-	24-392	25	21/64"

*Length measured from under head.*

† Hex Head Thread Cutting Screws are stocked in slotted and unslotted. Regrettably, we cannot guarantee shipment of any specific head type.

VISIT OUR WEBSITE  
[mpi-online.com](http://mpi-online.com)  
 FAX ANYTIME!  
**219-696-6413**



**HEX HEAD THREAD CUTTING SCREW ASSORTMENT**  
 24 SIZES, #6-3/8" DIA. HEX HEAD SCREWS UP TO 1-1/2" LG.  
 IN A LARGE STEEL DRAWER. **PART NO. 16-1924**



# Drywall Screws

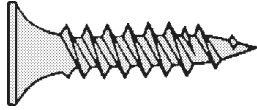

Phillips bugle head, fine threads, genuine Twinfast sharp point. Hardened steel. Black phosphate finish. Length measured overall.

Order by number of pieces. Sold in full packages only.

SIZE	100 PAK	5 LB. PKG	BULK PKG
6 x 1"	24-690 <sub>100</sub>	24-800 <sub>1,570</sub>	24-818 <sub>10,000</sub>
6 x 1-1/8	24-792 <sub>100</sub>	24-801 <sub>1,455</sub>	24-819 <sub>10,000</sub>
6 x 1-1/4	24-691 <sub>100</sub>	24-802 <sub>1,340</sub>	24-820 <sub>8,000</sub>
6 x 1-5/8	24-692 <sub>100</sub>	24-803 <sub>1,060</sub>	24-821 <sub>5,000</sub>
6 x 2"	24-693 <sub>100</sub>	24-804 <sub>890</sub>	24-822 <sub>3,500</sub>
6 x 2-1/4	24-793 <sub>100</sub>	24-805 <sub>770</sub>	24-823 <sub>3,000</sub>
8 x 2-1/2	24-694 <sub>100</sub>	24-806 <sub>525</sub>	24-824 <sub>2,500</sub>
8 x 3"	24-695 <sub>100</sub>	24-807 <sub>425</sub>	24-825 <sub>2,000</sub>
10 x 3-1/2	-	-	-
10 x 3-3/4	24-794 <sub>100</sub>	24-808 <sub>260</sub>	24-827 <sub>800</sub>
10 x 4"	-	-	-
10 x 4-1/2	-	24-809 <sub>210</sub>	24-829 <sub>500</sub>
10 x 5"	-	24-810 <sub>190</sub>	24-830 <sub>500</sub>
10 x 6"	-	24-811 <sub>160</sub>	24-831 <sub>400</sub>

# Deck Screws

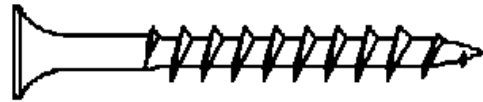

Phillips bugle head, coarse threads. Hardened steel. Used on exterior wood decks and building projects. Special corrosion resistant finish. Length measured overall.

Order by number of pieces. Sold in full packages only.

SIZE	100 PAK	5 LB. PKG	BULK PKG
6 x 1"	-	-	-
6 x 1-1/8	-	-	-
6 x 1-1/4	24-795 <sub>100</sub>	24-812 <sub>1,340</sub>	24-832 <sub>8,000</sub>
6 x 1-5/8	24-796 <sub>100</sub>	24-813 <sub>1,060</sub>	24-833 <sub>5,000</sub>
6 x 2"	24-797 <sub>100</sub>	24-814 <sub>890</sub>	24-834 <sub>3,500</sub>
6 x 2-1/4	-	-	-
8 x 2-1/2	24-798 <sub>100</sub>	24-815 <sub>525</sub>	24-835 <sub>2,500</sub>
8 x 3"	24-799 <sub>100</sub>	24-816 <sub>425</sub>	24-836 <sub>2,000</sub>
10 x 3-1/2	-	24-817 <sub>280</sub>	24-837 <sub>1,000</sub>
10 x 3-3/4	-	-	-
10 x 4"	-	-	24-838 <sub>1,000</sub>
10 x 4-1/2	-	-	-
10 x 5"	-	-	-
10 x 6"	-	-	-

# Self-Drilling Drywall Screws

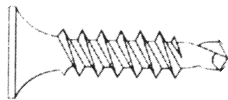

Self-drilling point fastens to metal studs up to 12 gauge (.105"). Phillips bugle head, fine threads. Hardened steel. Black phosphate finish.

Size	PART NUMBER	
	100/ea	1000/ea
6 x 1"	24-006	24-010
6 x 1-1/4	24-008	24-011
6 x 1-5/8	24-013	24-020
6 x 1-7/8	24-014	24-021
8 x 2-3/8	24-015	24-023
8 x 2-5/8	24-018	24-025



**DRYWALL & DECK SCREW ASSORTMENT**  
11 SIZES, #6-#8 DIA. UP TO 3" LG. WITH BIT HOLDER AND INSERT BITS IN A LARGE STEEL DRAWER.  
**PART NO. 16-4712**

# Steel Wood Screws

Sharp threads and points. Flat head screws have 82° angle. 1018 low carbon steel.  
Bright zinc finish. Pkg: 100

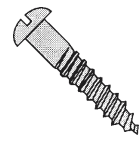
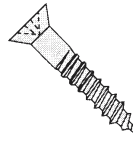
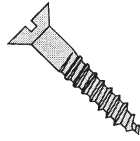
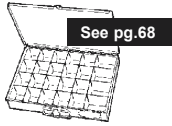

Size	Flat Slotted Part No.	Flat Phillips Part No.	Round Slotted Part No.
4 x 3/8	18-336	-	-
4 x 1/2	18-001	-	-
4 x 5/8	18-002	-	-
4 x 3/4	18-003	-	-
4 x 1"	18-004	-	-
5 x 3/8	18-006	-	-
5 x 1/2	18-007	-	-
5 x 5/8	18-338	-	-
5 x 3/4	18-008	-	-
5 x 1"	18-009	-	-
6 x 3/8	18-340	-	-
6 x 1/2	18-011	18-426	18-105
6 x 5/8	18-012	-	18-412
6 x 3/4	18-013	18-165	18-106
6 x 7/8	18-014	-	18-413
6 x 1"	18-015	18-166	18-107
6 x 1-1/4	18-016	18-167	18-108
6 x 1-1/2	18-017	18-427	18-109
6 x 1-3/4	18-018	-	18-110
6 x 2"	18-019	18-428	18-111
6 x 2-1/2	18-020	-	18-112
8 x 1/2	18-026	18-429	18-117
8 x 5/8	18-027	-	-
8 x 3/4	18-028	18-430	18-118
8 x 1"	18-030	18-169	18-120
8 x 1-1/4	18-031	18-431	18-121
8 x 1-1/2	18-032	18-170	18-122
8 x 1-3/4	-	-	18-123
8 x 2"	18-034	18-432	18-124
8 x 2-1/4	-	-	18-125
8 x 2-1/2	18-035	18-433	18-126
8 x 3"	18-036	18-434	18-127
10 x 1/2	18-044	-	18-132
10 x 5/8	18-045	-	-
10 x 3/4	18-046	18-435	18-133
10 x 7/8	18-348	-	-
10 x 1"	18-047	18-171	18-134
10 x 1-1/4	18-048	18-436	18-135
10 x 1-1/2	18-049	18-172	18-136
10 x 1-3/4	18-050	-	18-137
10 x 2"	18-051	18-437	18-138
10 x 2-1/4	18-052	-	18-139

Continued next page.



# Steel Wood Screws (Cont'd)

Sharp threads and points. Flat head screws have 82° angle. 1018 low carbon steel.  
Bright zinc finish. Pkg: 100

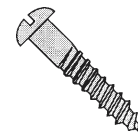
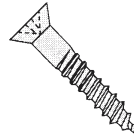
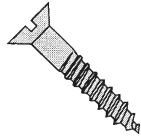

Size	Flat Slotted Part No.	Flat Phillips Part No.	Round Slotted Part No.
10 x 2-1/2	18-053	18-173	18-140
10 x 2-3/4	18-054	-	-
10 x 3"	18-055	18-174	-
10 x 3-1/2	18-056	-	-
10 x 4"	18-057	-	-
12 x 3/4	18-058	18-438	18-143
12 x 7/8	18-059	-	18-144
12 x 1"	18-060	18-439	18-145
12 x 1-1/4	18-061	18-440	18-146
12 x 1-1/2	18-062	18-441	18-147
12 x 1-3/4	18-063	-	18-148
12 x 2"	18-064	18-442	18-149
12 x 2-1/4	18-065	-	18-150
12 x 2-1/2	18-066	18-443	18-151
12 x 2-3/4	18-067	-	-
12 x 3"	18-068	18-444	18-152
12 x 3-1/2	18-069	18-445	18-153
12 x 4"	18-070	18-175	18-154
14 x 3/4	18-071	18-446	18-155
14 x 1"	18-072	18-447	18-156
14 x 1-1/4	18-073	18-448	18-157
14 x 1-1/2	18-074	18-449	18-158
14 x 1-3/4	18-075	-	-
14 x 2"	18-076	18-450	18-159
14 x 2-1/4	18-077	-	-
14 x 2-1/2	18-078	18-451	18-160
14 x 3"	18-079	18-452	18-161
14 x 3-1/2	18-080	18-453	18-162
14 x 4"	18-081	18-454	18-163
14 x 4-1/2	18-350	-	-
14 x 5"	18-351	-	-
14 x 6"	18-352	-	-



*Pepsi's "Come Alive With the  
Pepsi Generation" translated into  
Chinese as "Pepsi Brings Your  
Ancestors Back From the Grave"*

**FLAT HD SLTD. WOOD SCREW ASSORTMENT**  
24 SIZES, #6-#14 DIA. UP TO 3" LG. IN A  
LARGE STEEL DRAWER. **PART NO. 16-2124**

# Sheet Metal Screws

Type A/AB point. Fully hardened steel. Sharp threads and points. Flat head screws have 82° angle.  
Bright zinc finish. Pkg: 100

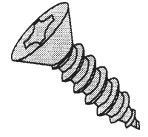
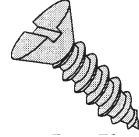
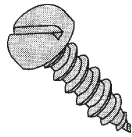
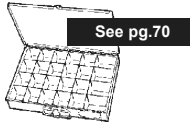

Size	Pan Slotted Part No.	Pan Phillips Part No.	Flat Slotted Part No.	Flat Phillips Part No.
4 x 1/4	24-047	-	24-117	-
4 x 3/8	24-048	-	24-118	24-499
4 x 1/2	24-049	-	24-119	-
4 x 5/8	24-050	-	24-120	-
4 x 3/4	24-051	-	24-121	-
4 x 1"	24-052	-	24-122	-
6 x 1/4	24-053	24-258	24-124	-
6 x 3/8	24-054	24-259	24-125	-
6 x 1/2	24-055	24-260	24-126	24-235
6 x 5/8	24-056	24-261	24-127	24-236
6 x 3/4	24-057	24-262	24-128	24-237
6 x 7/8	24-058	-	-	-
6 x 1"	24-059	24-263	24-129	-
6 x 1-1/4	24-060	24-264	24-130	-
6 x 1-1/2	24-061	24-265	24-131	-
6 x 2"	24-062	-	-	-
7 x 3/8	24-063	-	-	-
7 x 1/2	24-064	-	-	-
7 x 5/8	24-065	-	-	-
7 x 3/4	24-066	-	-	-
7 x 1"	24-067	-	-	-
7 x 1-1/4	24-068	-	-	-
7 x 1-1/2	24-069	-	-	-
8 x 1/4	24-070	24-267	-	-
8 x 3/8	24-071	24-268	24-133	-
8 x 1/2	24-072	24-269	24-134	24-238
8 x 5/8	24-073	24-270	24-135	24-239
8 x 3/4	24-074	24-271	24-136	24-240
8 x 7/8	24-075	24-497	24-137	-
8 x 1"	24-076	24-272	24-138	24-241
8 x 1-1/4	24-077	24-273	24-139	24-242
8 x 1-1/2	24-078	24-274	24-140	24-243
8 x 1-3/4	24-079	24-275	-	-
8 x 2"	24-080	-	24-141	-
8 x 2-1/2	24-081	-	24-142	-
10 x 3/8	24-083	24-276	24-143	-
10 x 1/2	24-084	24-277	24-144	24-244
10 x 5/8	24-085	24-278	24-145	24-245

Continued next page.

## LAST WILL AND TESTAMENT

**Being of sound mind, I spent all my money.**



# Sheet Metal Screws (Cont'd)

Type A/AB point. Fully hardened steel. Sharp threads and points. Flat head screws have 82° angle.  
Bright zinc finish. Pkg: 100

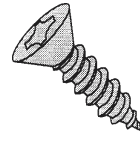
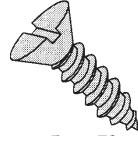
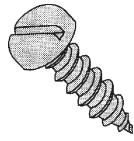

Size	Pan Slotted Part No.	Pan Phillips Part No.	Flat Slotted Part No.	Flat Phillips Part No.
10 x 3/4	24-086	24-279	24-146	24-246
10 x 7/8	24-087	24-280	-	-
10 x 1"	24-088	24-281	24-147	24-247
10 x 1-1/4	24-089	24-282	24-148	24-248
10 x 1-1/2	24-090	24-283	24-149	24-249
10 x 1-3/4	24-091	24-284	24-150	-
10 x 2"	24-092	24-285	24-151	24-250
10 x 2-1/2	24-093	-	24-152	-
10 x 3"	24-094	-	24-153	-
12 x 1/2	24-095	24-498	24-154	-
12 x 5/8	24-096	24-286	24-490	-
12 x 3/4	24-097	24-287	24-155	24-251
12 x 7/8	24-098	-	-	-
12 x 1"	24-099	24-288	24-156	24-252
12 x 1-1/4	24-100	24-289	24-157	24-253
12 x 1-1/2	24-101	24-290	24-158	24-254
12 x 1-3/4	24-102	-	24-159	-
12 x 2"	24-103	-	24-160	-
12 x 2-1/2	24-104	-	-	-
12 x 3"	24-105	-	24-161	-
14 x 1/2	24-106	24-291	-	-
14 x 5/8	24-107	24-292	24-162	-
14 x 3/4	24-108	24-293	24-163	24-503
14 x 7/8	24-109	24-294	-	-
14 x 1"	24-110	24-295	24-164	24-255
14 x 1-1/4	24-111	24-296	24-165	-
14 x 1-1/2	24-112	24-297	24-166	24-256
14 x 1-3/4	24-113	24-298	24-167	-
14 x 2"	24-114	24-299	24-168	24-504
14 x 2-1/2	24-115	-	24-169	-
14 x 3"	24-116	-	24-170	-

**PAN SLOTTED SMS MAINTENANCE KIT**  
12 SIZES, #6 THRU #14. PART NO. 500MK



**PAN PHILLIPS PAN SMS MAINTENANCE KIT**  
12 SIZES, #6 THRU #14 PART NO. 501MK



**PAN SLOTTED SMS ASSORTMENT**  
24 SIZES, #6 THRU #14 UP TO 1-1/2" LONG IN  
LARGE STEEL DRAWER. PART NO. 16-0724

**PAN PHILLIPS SMS ASSORTMENT**  
24 SIZES, #6 THRU #14 UP TO 1-1/2" LONG IN  
LARGE STEEL DRAWER. PART NO. 16-0824

# Automotive Trim Screws

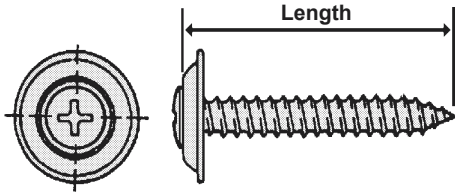

**Phillips Oval Head  
Sems® Finishing Screws**  
Black phosphate finish.

Size	Part No.	Pkg Qty
6 x 5/8	24-624	100
6 x 3/4	24-625	100
6 x 1"	24-626	100
8 x 5/8	24-627	100
8 x 3/4	24-628	100
8 x 1"	24-629	100
8 x 1-1/4	24-630	100
10 x 3/4	24-631	50
10 x 1"	24-632	50



**Black Oxide  
Phillips Pan Hd Sheet Metal Screws**  
Hardened steel

Size	Part No.	Pkg
6 x 1/2	24-11917	100
6 x 3/4	24-11918	100
6 x 1"	24-11919	100
8 x 1/2	24-633	100
8 x 3/4	24-634	100
8 x 1"	24-635	100
8 x 1-1/4	24-636	100
8 x 1-1/2	24-12799	100
10 x 1/2	24-11921	100
10 x 3/4	24-11922	100
10 x 1"	24-11923	100
10 x 1-1/4	24-11924	100
10 x 1-1/2	24-12800	100



**OEM & PAN HD. PHILLIPS TRIM SCREW ASSORTMENT**  
24 SIZES, #6 - #10 UP TO 1-1/2" LONG IN A LARGE  
STEEL DRAWER. **PART NO. 16-1124**

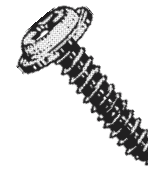

**OEM Phillips Washer Head  
Trim Screw**

Special head style for automotive trim  
Hardened steel. Black oxide finish.

Size	Part No.	Pkg
6 x 1/2	24-12950	100
6 x 3/4	24-12951	100
6 x 1"	24-12952	100
8 x 1/2	24-12213	100
8 x 3/4	24-12215	100
8 x 1"	24-12216	100
8 x 1-1/4	24-12217	100
8 x 1-1/2	24-12218	100
10 x 3/4	24-12953	100
10 x 1"	24-12954	100
10 x 1-1/4	24-12955	100

**MPI CAN BECOME YOUR SINGLE-SOURCE SUPPLIER ON  
MANY OF THE PARTS YOU CURRENTLY USE!**



# Phillips Oval Hd. Sheet Metal Screws

(Tapping Screws)

Deep phillips recess for non-slip driving. Sharp threads and points. Made from hardened steel. Use "reduced head" sizes when existing holes has been stripped. Pkg: 100 each.

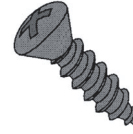
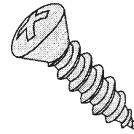
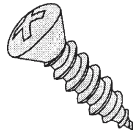
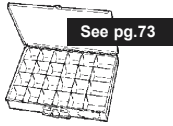
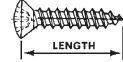

Size	Zinc Part No.	Chrome Part No.	Blk Oxide Part No.
4 x 1/4	24-505	-	24-907
4 x 3/8	24-506	24-865	24-908
4 x 1/2	24-189	24-866	24-909
4 x 5/8	24-507	24-867	24-910
4 x 3/4	24-190	24-868	24-911
6 x 3/8 4 Hd	-	24-870	-
6 x 3/8	24-193	-	-
6 x 1/2	24-194	24-872	24-12795
6 x 5/8	24-195	24-873	-
6 x 3/4 4 Hd	24-839	-	-
6 x 3/4	24-196	24-874	24-12796
6 x 7/8	24-197	-	-
6 x 1"	24-198	24-876	24-12797
6 x 1-1/4	24-199	24-877	24-12798
8 x 3/8 6 Hd	24-840	24-528	-
8 x 3/8	24-200	24-878	-
8 x 1/2 6 Hd	24-841	24-529	24-606
8 x 1/2	24-201	24-879	24-601
8 x 5/8 6 Hd	24-842	24-530	-
8 x 5/8	24-202	24-880	-
8 x 3/4 6 Hd	24-843	24-531	24-607
8 x 3/4	24-203	24-881	24-602
8 x 7/8 6 Hd	24-844	24-532	-
8 x 7/8	24-204	24-882	-
8 x 1" 6 Hd	24-845	24-533	24-608
8 x 1"	24-205	24-883	24-603
8 x 1-1/8 6 Hd	-	24-884	-
8 x 1-1/8	-	24-885	-
8 x 1-1/4 6 Hd	24-846	24-534	24-609
8 x 1-1/4	24-206	24-886	24-604
8 x 1-1/2 6 Hd	-	24-887	24-610
8 x 1-1/2	24-207	24-888	24-605
8 x 1-3/4 6 Hd	-	24-536	-
8 x 1-3/4	24-208	-	-
8 x 2" 6 Hd	-	24-889	-
8 x 2"	24-209	-	-
8 x 2-1/4 6 Hd	24-847	-	-
8 x 2-1/4	24-210	-	-
8 x 2-1/2 6 Hd	24-848	-	-
8 x 2-1/2	24-211	-	-
8 x 3"	-	24-890	-
10 x 1/2 6 Hd	24-849	24-541	-
10 x 1/2 8 Hd	24-850	24-553	24-616
10 x 1/2	24-213	24-892	24-611
10 x 5/8 6 Hd	-	24-542	-
10 x 5/8 8 Hd	-	24-554	-
10 x 5/8	24-214	24-893	-

Continued next page.



# Phillips Oval Hd. Sheet Metal Screws (Cont'd)

Deep phillips recess for non-slip driving. Sharp threads and points. Made from hardened steel. Use "reduced head" sizes when existing holes has been stripped. Pkg: 100 each.

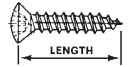

Size		Zinc Part No.	Chrome Part No.	Blk Oxide Part No.
10 x 3/4	6 Hd	24-852	24-543	-
10 x 3/4	8 Hd	24-853	24-555	24-617
10 x 3/4		24-215	24-894	24-612
10 x 7/8	6 Hd	-	24-544	-
10 x 7/8		24-509	-	-
10 x 1"	6 Hd	24-854	24-545	-
10 x 1"	8 Hd	-	24-557	24-618
10 x 1"		24-216	24-896	24-613
10 x 1-1/8		-	24-897	-
10 x 1-1/4	6 Hd	24-855	24-546	-
10 x 1-1/4	8 Hd	24-856	24-558	24-619
10 x 1-1/4		24-217	24-898	24-614
10 x 1-3/8		24-857	-	-
10 x 1-1/2	6 Hd	24-858	24-548	-
10 x 1-1/2	8 Hd	24-560	24-899	24-620
10 x 1-1/2		24-218	24-900	24-615
10 x 1-3/4	6 Hd	24-859	24-901	-
10 x 1-3/4	8 Hd	24-860	-	-
10 x 1-3/4		24-510	24-903	-
10 x 2"	8 Hd	24-861	24-904	-
10 x 2"		24-511	24-905	-
10 x 2-1/2	8 Hd	24-864	-	-
10 x 2-1/2		24-513	24-906	-
12 x 1/2		24-219	-	-
12 x 3/4	8 Hd	24-567	-	-
12 x 3/4	10 Hd	24-576	-	-
12 x 3/4		24-221	-	-
12 x 1"	10 Hd	24-578	-	-
12 x 1"		24-222	-	-
12 x 1-1/4		24-223	-	-
12 x 1-1/2	10 Hd	24-580	-	-
12 x 1-1/2		24-224	-	-
12 x 2"		24-515	-	-
14 x 1"		24-229	-	-
14 x 1-1/4		24-230	-	-
14 x 1-1/2		24-231	-	-



**ZINC PHILLIPS OVAL HD. SMS ASSORTMENT**  
24 SIZES, #6 THRU #14 UP TO 1-1/2" LG. IN LARGE  
STEEL DRAWER. **PART NO. 16-0924**



**BLACK-OXIDE PHILLIPS OVAL HD. SMS ASSORTMENT**  
24 SIZES, #6 THRU #14 UP TO 1-1/2" LG.  
IN LARGE STEEL DRAWER. **PART NO. 16-1024**





# Square Drive Screws

(Robertson™ Drive Screws)



Deep square recess for excellent torque and non-slip driving. Grips to driver as if by magnetism. This relatively tamperproof screw ideal for security system installations. Hardened steel.

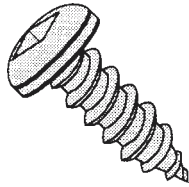

## Pan Head Sheet Metal Screws

Type A point. Zinc finish. Pkg: 100 each.

Part Size	Bit No.	No.
6 x 1/2	24-912	1
6 x 3/4	24-913	1
6 x 1"	24-914	1
8 x 1/2	24-915	2
8 x 3/4	24-916	2
8 x 1"	24-917	2
8 x 1-1/4	24-918	2
8 x 1-1/2	24-919	2
10 x 1/2	24-920	2
10 x 3/4	24-921	2
10 x 1"	24-922	2
10 x 1-1/4	24-923	2
10 x 1-1/2	24-924	2
10 x 2	24-925	2

Length measured from under head.

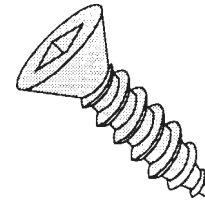

## Flat Head Sheet Metal Screws

Type A point. Zinc finish. Pkg: 100 each.

Size	Part No.	Bit No.
6 x 1/2	24-926	1
6 x 3/4	24-927	1
6 x 1"	24-928	1
8 x 3/4	24-929	2
8 x 1"	24-930	2
8 x 1-1/4	24-931	2
8 x 1-1/2	24-932	2
10 x 3/4	24-933	2
10 x 1"	24-934	2
10 x 1-1/4	24-935	2
10 x 1-1/2	24-936	2
10 x 2	24-937	2

Length measured overall.



## Flat Head Wood Screws

Twin fast point. Zinc finish. Pkg: 100 each.

Size	Part No.	Bit No.
6 x 1"	18-082	1
6 x 1-1/2	18-083	1
8 x 2"	18-084	2
8 x 2-1/2	18-085	2
8 x 3"	18-086	2
10 x 3"	18-087	2

Length measured overall.

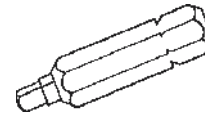

## Square Recess Insert Bits

1/4" hex shank, 1" long

Pkg: 10 each

Part No.	Point Size	Screw Sizes
6797	0	3, 4
6798	1	5, 6, 7
6799	2	8, 10
6800	3	12, 1/4

May you live all the days of your life.

-Jonathan Swift

# One Way Security Screws

(Tamperproof Screws)

Designed to install with an ordinary screwdriver, but removal requires special tools shown below. No screwdriver, coin or knife blade can be used to remove these fasteners. Ideal for schools, hotels, hospitals, dormitories, alarm installations, prisons and institutions. Applications: bathroom partitions, signs, fixtures, hinges, door locks, alarm devices, access panels, etc. Zinc finish.



## Round Head Sheet Metal Screws

Hardened steel. Type A point. Zinc finish.

Size	Part No.	Drill Size	Pkg Qty
6 x 1/2	24-637	3/32"	100
6 x 3/4	24-638	3/32"	100
8 x 1/2	24-639	1/8"	100
8 x 3/4	24-640	1/8"	100
8 x 1"	24-641	1/8"	100
8 x 1-1/4	24-642	1/8"	100
10 x 1/2	24-643	9/64"	100
10 x 3/4	24-645	9/64"	100
10 x 1"	24-646	9/64"	100
10 x 1-1/2	24-648	9/64"	50
14 x 1"	24-649	3/16"	50
14 x 1-1/2	24-650	3/16"	50

Sizes and styles not shown may be available on special request, subject to minimum packaging.



**SECURITY RD. HD. SMS ASSORTMENT**  
11 SIZES, #6 THRU #14 UP TO 1" LG. IN A CLEAR POLYSTYRENE BOX. **PART NO.547MK**



**SECURITY RD. HD. MACHINE SCREW ASSORTMENT**  
SIZES #6 THRU #14 IN A CLEAR POLYSTYRENE BOX. **PART NO.552MK**



## Round Head Machine Screws

Zinc finish.

Size	Part No.	Pkg Qty
6-32 x 1/2	24-653	100
6-32 x 3/4	24-660	100
8-32 x 3/4	24-661	100
8-32 x 1"	24-662	100
8-32 x 1-1/2	24-663	100
10-24 x 3/4	24-664	100
10-24 x 1"	24-665	100
10-24 x 1-1/2	24-666	50
10-32 x 3/4	24-667	100
10-32 x 1"	24-668	100
10-32 x 1-1/2	24-669	50
1/4-20 x 3/4	24-670	50
1/4-20 x 1"	24-671	50
1/4-20 x 1-1/2	24-672	50
1/4-20 x 2"	24-673	50
1/4-20 x 3"	24-674	50

## One Way Screw Removal Tools



Designed for one way security screws only†.

Part No.	Remove Sizes
24-675	4, 6, 8
24-676	10, 12
24-677	1/4" (#14), 5/16", 3/8"

†Note: This tool will not install or remove two-hole type spanner screws. Spanner drivers are available on special request.



# Hex Head Sheet Metal Screws

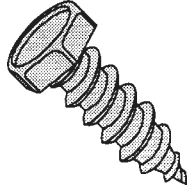

## Hex Head Sheet Metal Screws

Unslotted, hex indented head.  
Fully hardened. Type A point. Sharp threads.  
Bright zinc finish.

Size	Head Size	Part No.	Drill Size	Pkg Qty
8 x 3/8	1/4"	24-411	1/8"	100
8 x 1/2	1/4"	24-412	1/8"	100
8 x 5/8	1/4"	24-413	1/8"	100
8 x 3/4	1/4"	24-414	1/8"	100
8 x 1"	1/4"	24-415	1/8"	100
8 x 1-1/4	1/4"	24-416	1/8"	100
8 x 1-1/2	1/4"	24-417	1/8"	100
10 x 1/2	5/16"	24-418	9/64"	100
10 x 5/8	5/16"	24-419	9/64"	100
10 x 3/4	5/16"	24-420	9/64"	100
10 x 1"	5/16"	24-422	9/64"	100
10 x 1-1/4	5/16"	24-423	9/64"	100
10 x 1-1/2	5/16"	24-424	9/64"	100
12 x 1/2	5/16"	24-425	5/32"	100
12 x 3/4	5/16"	24-427	5/32"	100
12 x 1"	5/16"	24-429	5/32"	100
12 x 1-1/4	5/16"	24-430	5/32"	100
12 x 1-1/2	5/16"	24-431	5/32"	100
12 x 2"	5/16"	24-432	5/32"	100
14 x 1/2	3/8"	24-517	3/16"	100
14 x 5/8	3/8"	24-518	3/16"	100
14 x 5/8	7/16"	24-434	3/16"	100
14 x 3/4	3/8"	24-519	3/16"	100
14 x 3/4	7/16"	24-435	3/16"	100
14 x 1"	7/16"	24-437	3/16"	100
14 x 1-1/4	7/16"	24-438	3/16"	100
14 x 1-1/2	7/16"	24-439	3/16"	100
14 x 2"	7/16"	24-441	3/16"	100
5/16 x 3/4	1/2"	24-444	7/32"	100
5/16 x 1"	1/2"	24-446	7/32"	100
5/16 x 1-1/4	1/2"	24-447	7/32"	100
5/16 x 1-1/2	1/2"	24-448	7/32"	100
5/16 x 2"	1/2"	24-450	7/32"	100
3/8 x 3/4	9/16"	24-451	1/4"	50
3/8 x 1"	9/16"	24-452	1/4"	50
3/8 x 1-1/4	9/16"	24-453	1/4"	50
3/8 x 1-1/2	9/16"	24-454	1/4"	50

*Length measured from under head.*

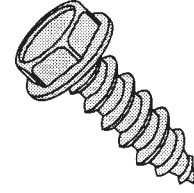

## Hex Washer Head Sheet Metal Screws

Unslotted, hex indented head. Attached washer.  
Fully hardened. Type A point. Sharp threads.  
Bright zinc finish.

Size	Head Size	Part No.	Drill Size	Pkg Qty
10 x 1/2	5/16"	24-171	9/64"	100
10 x 5/8	5/16"	24-172	9/64"	100
12 x 1/2	5/16"	24-520	5/32"	100
12 x 5/8	5/16"	24-521	5/32"	100
12 x 3/4	5/16"	24-174	5/32"	100
12 x 1"	5/16"	24-175	5/32"	100
14 x 1/2	3/8"	24-178	3/16"	100
14 x 5/8	3/8"	24-522	3/16"	100
14 x 5/8	7/16"	24-179	3/16"	100
14 x 3/4	3/8"	24-523	3/16"	100
14 x 3/4	7/16"	24-180	3/16"	100
14 x 1"	7/16"	24-181	3/16"	100
14 x 1-1/4	7/16"	24-182	3/16"	100
14 x 1-1/2	7/16"	24-183	3/16"	100
5/16 x 5/8	7/16"	24-184	7/32"	100
5/16 x 3/4	7/16"	24-185	7/32"	100
5/16 x 1"	7/16"	24-186	7/32"	100
5/16 x 1-1/4	7/16"	24-187	7/32"	100
5/16 x 1-1/2	7/16"	24-188	7/32"	100



**HEX HD SHEET METAL SCREW ASSORTMENT**  
24 SIZES, #8 - 3/8" DIA. REGULAR HEX AND HEX WASHER HEAD, UP TO 2" LG., IN A LARGE STEEL DRAWER.  
**PART NO. 16-1424**

# Hex Head Sheet Metal Screws

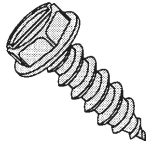

## Slotted Hex Washer Head Type A Sheet Metal Screws

Fully hardened. Sharp threads. Bright zinc finish.

All Pkg: 100 each

Size	Hex Size	Part No.	Drill Size
6 x 3/8	1/4"	24-456	3/32"
6 x 1/2	1/4"	24-457	3/32"
6 x 5/8	1/4"	24-458	3/32"
6 x 3/4	1/4"	24-459	3/32"
6 x 1"	1/4"	24-460	3/32"
6 x 1-1/4	1/4"	24-461	3/32"
6 x 1-1/2	1/4"	24-462	3/32"
8 x 3/8	1/4"	24-463	1/8"
8 x 1/2	1/4"	24-464	1/8"
8 x 5/8	1/4"	24-465	1/8"
8 x 3/4	1/4"	24-466	1/8"
8 x 1"	1/4"	24-467	1/8"
8 x 1-1/4	1/4"	24-468	1/8"
10 x 3/8	5/16"	24-470	9/64"
10 x 1/2	5/16"	24-471	9/64"
10 x 5/8	5/16"	24-472	9/64"
10 x 3/4	5/16"	24-473	9/64"
10 x 1"	5/16"	24-474	9/64"
10 x 1-1/4	5/16"	24-475	9/64"
10 x 1-1/2	5/16"	24-476	9/64"
12 x 1/2	5/16"	24-477	5/32"
12 x 5/8	5/16"	24-478	5/32"
12 x 3/4	5/16"	24-479	5/32"
12 x 1"	5/16"	24-480	5/32"
12 x 1-1/4	5/16"	24-481	5/32"
12 x 1-1/2	5/16"	24-482	100



**HEX WASHER HD SLOTTED SMS ASSORTMENT**  
24 SIZES, #6 - 5/16" DIA. UP TO 1-1/2" LG. IN A  
LARGE STEEL DRAWER. **PART NO. 16-1324**

## Zip-In Drill Screws

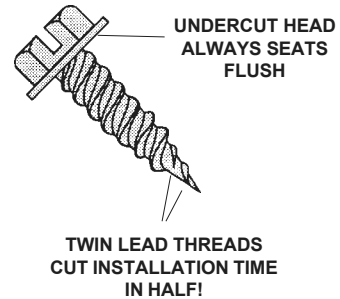

Sharp pointed, self-piercing screw that drills its own hole in metal up to 1/16" (.0625"). Penetrates multiple layers of sheet metal. Twin lead double thread design works fast. Single starting thread is machined down to very tip of screw point. Instantly penetrates and engages in heavy gauge sheet metal and layered light gauge. Hex washer head, slotted. Heat-treated steel. Bright zinc finish.

Size	Hex Size	Part No.	Pkg Qty
6 x 3/8	1/4"	24-654	100
7 x 1/2	1/4"	24-655	100
8 x 1/2	1/4"	24-656	100
8 x 3/4	1/4"	24-657	100
10 x 1/2	1/4"	24-658	100
10 x 3/4	1/4"	24-659	100

*Length measured from under head.*

## Magnetic Nutsetters

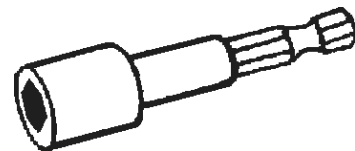

For hex screws and nuts. Magnetic to hold screw while positioning. Made of shock resistant tool steel and heat-treated for maximum strength and hardness.

**ALL 1/4" HEX SHANK, 2-9/16" LONG**

Hex Size	Part No.	Pkg Qty
1/4	6771	10
5/16	6772	10
3/8	6773	10
7/16"	6774	10



# Self-Drilling Tek<sup>®</sup> Screws

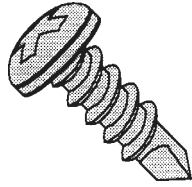

## Pan Head Phillips Self-Drilling Tek<sup>®</sup> Screws

Drills, taps, and fastens in one operation.  
Hardened steel. Zinc finish. Pkg: 100 each

Part No.	Size	Max. Thickness Drillable
24-938	6 x 3/8	.100 (12 GA)
24-939	6 x 1/2	.100 (12 GA)
24-940	6 x 5/8	.100 (12 GA)
24-941	6 x 3/4	.100 (12 GA)
24-942	6 x 1"	.100 (12 GA)
24-333	8 x 1/2	.100 (12 GA)
24-334	8 x 3/4	.100 (12 GA)
24-944	8 x 1"	.100 (12 GA)
24-946	8 x 1-1/2	.100 (12 GA)
24-335	10 x 1/2	.175 (7 GA)
24-947	10 x 5/8	.175 (7 GA)
24-336	10 x 3/4	.175 (7 GA)
24-337	10 x 1"	.175 (7 GA)

*Length measured from under head.  
Tek<sup>®</sup> screws also available in stainless steel.*



**HEX & PAN HD. TEK SCREW ASSORTMENT**  
20 SIZES, #8 - 14 DIA. UP TO 1-1/2" LG. IN A LARGE  
STEEL DRAWER. **PART NO. 16-0620**

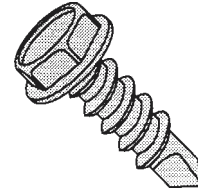

## Hex Washer Head Self-Drilling Tek<sup>®</sup> Screw

Drills, taps, and fastens in one operation.  
Hardened steel. Zinc finish. Pkg: 100 each

Part No.	Size	Max. Thickness Drillable	Hex Size
24-950	6-20 x 3/8	.100 (12 GA)	1/4
24-951	6-20 x 1/2	.100 (12 GA)	1/4
24-332	8-18 x 1/2	.100" (12 GA.)	1/4
24-317	8-18 x 3/4	.100" (12 GA.)	1/4
24-318	8-18 x 1"	.100" (12 GA.)	1/4
24-319	10-16 x 1/2	.175" (7 GA.)	5/16
24-320	10-16 x 5/8	.175" (7 GA.)	5/16
24-321	10-16 x 3/4	.175" (7 GA.)	5/16
24-322	10-16 x 1"	.175" (7 GA.)	5/16
24-323	10-16 x 1-1/4	.175" (7 GA.)	5/16
24-324	10-16 x 1-1/2	.175" (7 GA.)	5/16
24-952	10-16 x 2	.175" (7 GA.)	5/16
24-325	12-14 x 3/4	.210" (5 GA.)	5/16
24-326	12-14 x 1"	.210" (5 GA.)	5/16
24-327	12-14 x 1-1/2	.210" (5 GA.)	5/16
24-953	12-14 x 2	.210" (5 GA.)	5/16
24-328	14-14 x 3/4	.250" (3 GA.)	3/8
24-329	14-14 x 1"	.250" (3 GA.)	3/8
24-330	14-14 x 1-1/4	.250" (3 GA.)	3/8
24-331	14-14 x 1-1/2	.250" (3 GA.)	3/8
24-954	14-14 x 2	.250" (3 GA.)	3/8

*Length measured from under head.  
Tek<sup>®</sup> screws also available in stainless steel.*



**HEX HD. TEK SCREW MAINTENANCE KIT**  
6 SIZES, #8 X 1/2" THRU 1/4" X 1" IN A CLEAR  
STYRENE BOX. **PART NO. 505MK**

# Construction Screws

**Weather Gard® Bond Seal Washers • Hardened carbon steel • Silver Senti long-life finish\***

Fasten building side panels as well as any application requiring a water tight seal. Preassembled and ready to use. *Weather Gard* bond sealing washers are composite of metal and high quality EPDM rubber securely bonded together to provide excellent sealing performance. Dish shape provides a low profile installation.

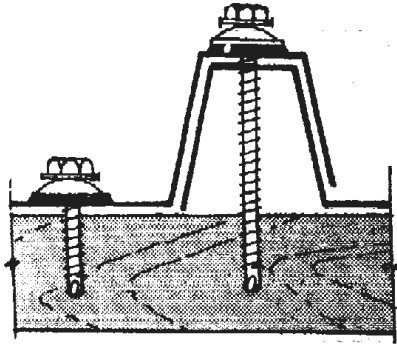

## For Metal Building Applications

Use Construction Screws for structural fastening in the crown or flat of sheet metal roofing or siding.

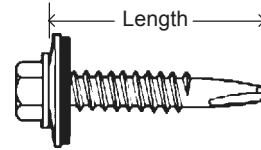

## #14 Drill Screws with Bond Sealing Washer

3/8" head size. Galvanized 5/8 O.D. sealing washer. *Silver Senti* long-life finish\*.

LONGER SIZES  
NOW IN STOCK!

Size	Part No.	Pkg Qty
14 x 3/4	24-525	100
14 x 1"	24-526	100
14 x 1-1/4	24-314	100
14 x 1-1/2	24-315	100
14 x 2"	24-316	100
14 x 2-1/2	24-406	100
14 x 3	24-407	100
14 x 4	24-408	100

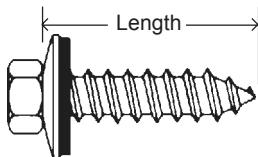

## #14 Type A Tapping Screw with Bond Sealing Washer

3/8" head size. Galvanizes 5/8 O.D. sealing washer. Recommended drill size: 3/16". Zinc plated.

Size	Part No.	Pkg Qty
14 x 3/4	24-308	100
14 x 1"	24-309	100
14 x 1-1/4	24-310	100
14 x 1-1/2	24-311	100
14 x 2"	24-312	100
14 x 2-1/2	24-313	100
14 x 3"	24-524	100

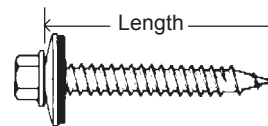

## WOODGRIP™ Drill Screws

Faster and stronger than nails! No hammer damage on panels or substructures. Self-drilling screw for metal roofing and siding to wooden structures.

1/4" head size. Galvanized 1/2" O.D. sealing washer. *Silver Senti* long-life finish\*.

Size	Part No.	Pkg Qty
10 x 1"	24-956	100
10 x 1-1/2	24-957	100
10 x 2"	24-958	100
10 x 2-1/2	24-959	100
10 x 3"	24-960	100

\**Silver Senti* is a special polymer barrier coating that offers exceptional corrosion protection to screw. Note: all bond sealing washers have galvanized finish. Sizes not shown may be available on special request, subject to minimum packaging.



# Self-Drilling Wall Liner Screws

Phillips Wafer Head

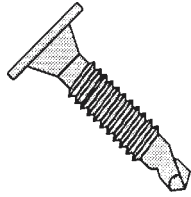

Use wall liner screws for attaching plywood to steel. Commonly used for wall liners inside trailers. Wafer head seats flush. No. 3 self-drilling tek point drills metals up to .175" thick. Head diameter: 1/2". Made from hardened steel. Bright zinc finish.

Part No.	Size	Applications	Pkg Qty
24-696	10-24 x 1"	3/8" plywood	100
24-697	10-24 x 1-1/4"	1/2" plywood	100
24-698	10-24 x 1-1/2"	3/4" plywood	100

*Length measured overall.*



**Now at MPI!**  
See page 327



**Over 14,000 automotive body clips and fasteners right at your fingertips! Call us for a free Au-Ve-Co Catalog.**

## - RIDDLE -

You are in a room with three light switches. Each one controls one lightbulb in the next room. You have to figure out which switch controls which bulb. You may flick two switches, and you may enter the room with the lightbulbs only once.

*Answer: Flick on switch #1, wait five minutes, then flick it off. Flick on switch #2. Now enter the room with the bulbs. The bulb that's on connects to switch #2. The bulb that feels hot goes with switch #1. The remaining bulb goes with switch #3.*



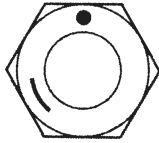

IFI standard grade marking\*

### Heat Treated Grade 5 Finished Hex Nuts

Proof load: 120,000 PSI minimum. Heat-treated low carbon steel. Meets or exceeds SAE J995 requirements. Rockwell Hardness: C32 Max. For use with Grade 2 or Grade 5 fasteners. Zinc finish.

Size	Part Number		Pkg Qty
	UNC	UNF	
1/4	08-2010	08-1010	100
	08-2011	08-1011	300
	08-2012	08-1012	1000
5/16	08-2020	08-1020	100
	08-2021	08-1021	300
	08-2022	08-1022	1000
3/8	08-2030	08-1030	100
	08-2031	08-1031	300
	08-2032	08-1032	1000
7/16	08-2040	08-1040	100
	08-2041	08-1041	300
	08-2042	08-1042	1000
1/2	08-2050	08-1050	100
	08-2051	08-1051	300
	08-2052	08-1052	1000
9/16	08-2060	08-1060	50
	08-2061	08-1061	150
5/8	08-2070	08-1070	50
	08-2071	08-1071	150
3/4	08-2080	08-1080	25
	08-2081	08-1081	100
7/8	08-2090	08-1090	25
	08-2091	08-1091	100
1"	08-2100	08-1100	25
	08-2101	08-1101	100
1-1/8	08-2110	08-1110	25
1-1/4	08-2120	08-1120	25
1-1/2	08-2140	08-1140	25

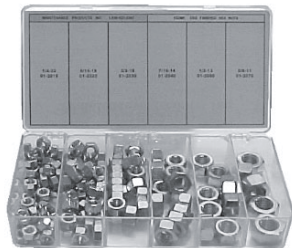

**UNC GR. 5 HEX NUT MAINTENANCE KIT**

6 SIZES, 1/4-20 - 5/8-11 (9/16" not included) COARSE THRD, IN A CLEAR POLYSTYRENE BOX. **PART NO. 532MK**

**UNF GR. 5 HEX NUT MAINTENANCE KIT**

6 SIZES, 1/4-28 - 5/8-18 (9/16" not included) FINE THRD, IN A CLEAR POLYSTYRENE BOX. **PART NO. 528MK**

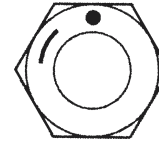

IFI standard grade marking\*

### Alloy Grade 8 Finished Hex Nuts

Proof load: 150,000 PSI minimum. High strength heat-treated alloy steel. Meets or exceeds SAE J995 requirements. Rockwell Hardness: C36 Max. For use with Grade 8 fasteners. Zinc gold dichromate finish.



**BLACK FINISH NOW IN STOCK!**

Items marked with a bullet (•) are now stocked with a black finish. Add the suffix "B" to part number when ordering.

Size	Part Number		Pkg Qty
	UNC	UNF	
1/4	36-2010•	36-1010	100
	36-2011	36-1011	300
	36-2012•	36-1012	1000
5/16	36-2020•	36-1020	100
	36-2021	36-1021	300
	36-2022	36-1022	1000
3/8	36-2030•	36-1030	100
	36-2031	36-1031	300
	36-2032	36-1032	1000
7/16	36-2040•	36-1040	100
	36-2041	36-1041	300
	36-2042	36-1042	1000
1/2	36-2050•	36-1050	100
	36-2051•	36-1051	300
	36-2052	36-1052	1000
9/16	36-2060•	36-1060	50
	36-2061	36-1061	150
	36-2070•	36-1070	50
5/8	36-2071•	36-1071	150
	36-2080•	36-1080	25
	36-2081•	36-1081	100
7/8	36-2090	36-1090	25
	36-2091	36-1091	100
	36-2100	36-1100	25
1"	36-2101	36-1101	100
	36-2110	36-1110	25
	36-2120	36-1120	25
1-3/8	36-2130	36-1130	25
1-1/2	36-2140	36-1140	25



Former grade 5 markings



Former grade 8 markings

\* Product standards require all grade-marked nuts 1/4" in diameter and larger to have insignia identifying its manufacturer. IFI standard grade markings shown at top of page.

**Hex Nut dimensions on pg. 83**



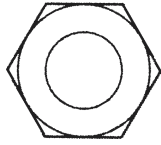

## Grade 2 Finished Hex Nuts

Proof load: 90,000 PSI minimum. Low carbon steel. Meets or exceeds SAE J995 requirements. Rockwell Hardness: B80-100 Max. For use with Grade 2 fasteners. Zinc finish. *For fine thread nuts see page 81.*

Size	Part Number UNC	Pkg Qty
1/4	01-2010	100
	01-2011	300
	01-2012	1000
5/16	01-2020	100
	01-2021	300
	01-2022	1000
3/8	01-2030	100
	01-2031	300
	01-2032	1000
7/16	01-2040	100
	01-2041	300
	01-2042	1000
1/2	01-2050	100
	01-2051	300
	01-2052	1000
9/16	01-2060	50
	01-2061	150
5/8	01-2070	50
	01-2071	150
3/4	01-2080	25
	01-2081	100
7/8	01-2090	25
	01-2091	100
1"	01-2100	25
	01-2101	100
1-1/8	01-2110	25
1-1/4	01-2120	25
1-3/8	01-2130	25
1-1/2	01-2140	25



## Automotive Hex Nuts

Smaller wrench size, used in automotive industry to match hex cap screw wrench size. Low carbon steel, zinc finish.

Part Number	Size	W.A.F.*	Thick -ness	Pkg Qty
03-207	7/16-14 (UNC)	5/8	3/8	100
03-208	7/16-20 (UNF)	5/8	3/8	100

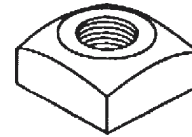

## Square Nuts

Coarse thread only. Low carbon steel. Zinc finish up to 1" diameter. Sizes over 1" are plain finish.

Size	Thick -ness	W.A.F.*	Part Number	Pkg Qty
6-32	0.114	5/16	03-067	100
8-32	0.130	11/32	03-068	100
10-24	0.130	3/8	03-069	100
10-32	0.161	3/8	03-070	100
1/4-20	7/32	7/16	03-071	100
5/16-18	17/64	9/16	03-072	100
3/8-16	21/64	5/8	03-073	100
7/16-14	3/8	3/4	03-074	100
1/2-13	7/16	13/16	03-075	100
5/8-11	35/64	1"	03-077	50
3/4-10	21/32	1-1/8	03-078	25
7/8-9	49/64	1-5/16	03-079	25
1"-8	7/8	1-1/2	03-080	25
1-1/8-7	1"	1-11/16	03-081	10
1-1/4-7	1-3/32	1-7/8	03-082	10



## Hex Jam Nuts

Approximately 2/3 the thickness of a full finished hex nut. Use against work surface, under a standard hex nuts to develop locking action. Low carbon steel, zinc finish.

Size	Thick -ness	Part Number UNC	Part Number UNF	Pkg Qty
1/4	5/32	03-041	03-054	100
5/16	3/16	03-042	03-055	100
3/8	7/32	03-043	03-056	100
7/16	1/4	03-044	03-057	100
1/2	5/16	03-045	03-058	100
9/16	5/16	03-046	03-059	50
5/8	3/8	03-047	03-060	50
3/4	27/64	03-048	03-061	25
7/8	31/64	03-049	03-062	25
1"	35/64	03-050	03-063	25
1-1/8	39/64	03-051	03-064	10
1-1/4	23/32	03-052	03-065	10
1-1/2	27/32	03-053	03-066	10

*Width across flats same as Finished Hex Nuts.*

\* W.A.F.: "Width Across Flats" (Wrench size)

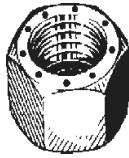

Grade mark - 9 dots or radial lines

## Alloy Grade 9 Finished Hex Nuts\*

Proof load: 180,000 PSI minimum. Special high strength heat-treated alloy steel. Thicker<sup>1</sup> for more wrenching surface. 20% stronger than Grade 8 hex nuts. Exceeds SAE J995 requirements. Rockwell Hardness: C38. Zinc gold dichromate finish. For use with Grade 9 fasteners. Made in U.S.A.

Size <sup>1</sup>	Part Number		Pkg Qty
	UNC	UNF	
1/4	34-4010	-	100
5/16	34-4020	-	50
3/8	34-4030	-	50
7/16	34-4040	-	25
1/2	34-4050	34-5050	25
9/16	34-4060	34-5060	25
5/8	34-4070	34-5070	25
3/4	34-4080	34-5080	20
7/8	34-4090	34-5090	15
1"	34-4100	34-5100	10
1-1/8	34-4110	34-5110	10
1-1/4	34-4120	34-5120	10

\*Grade 9 Stover Lock Nuts also available on special request, subject to minimum packaging.

<sup>1</sup>Bolt size is the approximate thickness dimension.

## Basic Dimensional Information for Finished Hex Nuts

Dimensions for Hex Nuts conform to ANSI/ASME B18.2.2

Diam.	Threads Per Inch		Basic W.A.F. <sup>2</sup>	Thick-ness <sup>3</sup>
	UNC	UNF		
1/4	-20	-28	7/16	7/32
5/16	-18	-24	1/2	17/64
3/8	-16	-24	9/16	21/64
7/16	-14	-20	11/16	3/8
1/2	-13	-20	3/4	7/16
9/16	-12	-18	7/8	31/64
5/8	-11	-18	15/16	35/64
3/4	-10	-16	1-1/8	41/64
7/8	-9	-14	1-5/16	3/4
1"	-8	-14	1-1/2	55/64
1-1/8	-7	-12	1-11/16	31/32
1-1/4	-7	-12	1-7/8	1-1/16
1-3/8	-6	-12	2-1/16	1-11/64
1-1/2	-6	-12	2-1/4	1-9/32

<sup>2</sup>Width across flats.

<sup>3</sup>Thickness does not include Grade 9 Hex Nuts.

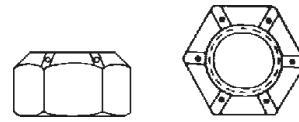

## Grade C Oval Lock Nuts

(All-steel Grade 8 Lock Nuts)

Heat-treated alloy steel. This reusable lock nut is rated for high prevailing torques. Withstands higher temperatures than nylon insert locking nuts. Use with grade 5 or grade 8 fasteners. Zinc and waxed finish.

Size	Part Number		Pkg Qty
	UNC	UNF	
1/4	36-4001	36-4101	100
5/16	36-4002	36-4102	100
3/8	36-4003	36-4103	100
7/16	36-4004	36-4104	100
1/2	36-4005	36-4105	100
9/16	36-4006	36-4106	50
5/8	36-4007	36-4107	50
3/4	36-4008	36-4108	25
7/8	36-4009	36-4109	25
1"	36-4010	36-4110	25
1-1/8	36-4011	36-4111	10
1-1/4	36-4012	36-4112	10
1-1/2	36-4014	36-4114	10

Width across flats same as Finished Hex Nuts.



**UNC/UNF THRD. GRADE C LOCK NUT ASSORTMENT**  
20 SIZES, 1/4 - 1" DIA.. COARSE AND FINE THREADS, IN A LARGE STEEL DRAWER. **PART NO. 16-0220**

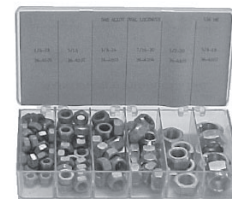

**UNC THRD. ALLOY GRADE C LOCK NUT KIT**  
6 SIZES, 1/4-20 - 5/8-11 (9/16" not included) COARSE THREAD, IN A CLEAR POLYSTYRENE BOX. **PART NO. 535MK**

**UNF THRD. ALLOY GRADE C LOCK NUT KIT**  
6 SIZES, 1/4-28 - 5/8-18 (9/16" not included) FINE THREAD, IN A CLEAR POLYSTYRENE BOX. **PART NO. 536MK**



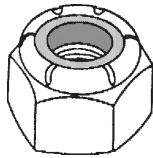

## Nylon Insert Lock Nuts

Low carbon steel. Leak resistant. Reusable.  
Temperature limit: +250°F. Zinc finish

Size	Thick -ness	Part Number		Pkg Qty
		UNC	UNF	
#4	9/64	36-4904	-	100
#6	3/16	36-4906	-	100
#8	15/64	36-4908	-	100
#10	1/4	36-4910	36-5100	100
#12	9/32	36-4912	-	100
1/4	5/16	36-5001	36-5101	100
5/16	11/32	36-5002	36-5102	100
3/8	29/64	36-5003	36-5103	100
7/16	29/64	36-5004	36-5104	100
1/2	19/32	36-5005	36-5105	100
9/16	21/32	36-5006	36-5106	50
5/8	3/4	36-5007	36-5107	50
3/4	7/8	36-5008	36-5108	25
7/8	1"	36-5009	36-5109	25
1"	1-5/64	36-5010	36-5110	25
1-1/8	1-3/16	36-5011	36-5111	10
1-1/4	1-13/32	36-5012	36-5112	10
1-1/2	1-5/8	36-5014	36-5114	10

Width across flats same as Regular Hex Nuts.



**NYLON LOCK NUT ASSORTMENT, UNC/UNF**  
18 SIZES, #10 - 3/4" COARSE & FINE THRD, IN A  
LARGE STEEL DRAWER. **PART NO. 16-0120**



**NYLON LOCK NUT MAINTENANCE KIT, UNC**  
6 SIZES, 1/4-20 THRU 5/8-11 (9/16" not included) COARSE  
THRD, IN A CLEAR POLYSTYRENE BOX. **PART NO. 507MK**

**NYLON LOCK NUT MAINTENANCE KIT, UNF**  
6 SIZES, 1/4-28 THRU 5/8-18 (9/16" not included) FINE THRD,  
IN A CLEAR POLYSTYRENE BOX. **PART NO. 527MK**

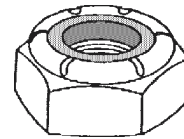

## Thin Pattern Nylon Insert Lock Nuts

Low carbon steel. Leak resistant. Reusable.  
Zinc finish.

Size	Thick -ness	Part Number		Pkg Qty
		UNC	UNF	
COARSE THREAD (UNC)				
1/4-20	0.218"	36-6001	-	100
5/16-18	0.265"	36-6002	-	100
3/8-16	0.281"	36-6003	-	100
7/16-14	0.328"	36-6004	-	100
1/2-13	0.328"	36-6005	-	100
FINE THREAD (UNF)				
1/4-28	0.218"	36-6101	-	100
5/16-24	0.265"	36-6102	-	100
3/8-24	0.281"	36-6103	-	100
7/16-20	0.328"	36-6104	-	100
1/2-20	0.328"	36-6105	-	100
9/16-18	0.362"	36-6106	-	50
5/8-18	0.406"	36-6107	-	50
3/4-16	0.421"	36-6108	-	25

Width across flats same as Finished Hex Nuts.

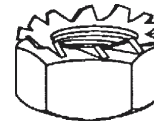

## Kep® Lock Nuts

Attached, free-spinning lockwasher. Zinc finish.

Size	Part Number		Pkg Qty
	UNC	UNF	
#4	03-094	-	100
#6	03-096	-	100
#8	03-098	-	100
#10	03-100	03-104	100
1/4	03-101	03-105	100
5/16	03-102	03-106	100
3/8	03-103	03-107	100

Hex Nut dimensions on pg. 83

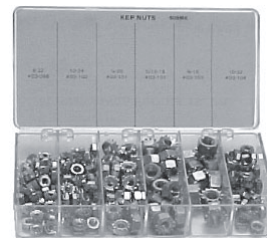

**KEP® NUT MAINTENANCE KIT**  
6 SIZES, #8-3/8" COARSE THRD AND 10-32 FINE THRD, IN A  
CLEAR POLYSTYRENE BOX. **PART NO. 509MK**

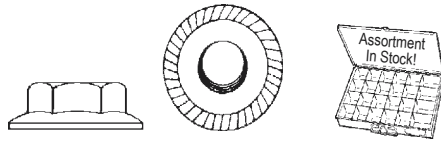

## Spin-Lock Serrated Flange Lock Nuts

("Whiz-Lock" Nuts)

Hardened steel • Zinc finish

Size	Part Number		Pkg Qty
	UNC	UNF	
#8	03-209	-	100
#10	03-210	03-216	100
1/4	03-211	03-217	100
5/16	03-212	03-218	100
3/8	03-213	03-219	100
7/16	03-214	03-220	50
1/2	03-215	03-221	50

Width across flats same as Finished Hex Nuts.

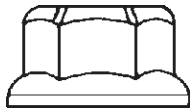

## Grade 8 Hex Flange Lock Nuts

High strength design for use with frame bolts and out-of-round holes. Tensile Strength: 150,000 PSI.

SAE J529K. Phosphate & oil finish.

Pkg Size	Part Number		Flange	
	UNC	UNF	Dia.	Qty
3/8	9-223	-	13/16	50
1/2	9-224	9-622	1-5/64	25
5/8	9-225	9-623	1-11/32	25
3/4	9-620	-	1-9/16	10

Width across flats same as Finished Hex Nuts.



## Hex Machine Screw Nuts

Low carbon steel, zinc finish.

Size	Thick -ness	W.A.F.*	Part No.	Part No.	Part No.
			100	300	1000
2-56	0.066	3/16	01-4020	-	-
4-40	0.098	1/4	01-4040	-	-
5-40	0.114	5/16	01-4050	-	-
6-32	0.114	5/16	01-4060	01-4061	01-4062
8-32	0.130	11/32	01-4080	01-4081	01-4082
10-24	0.130	3/8	01-4100	01-4101	01-4102
10-32	0.130	3/8	01-4110	01-4111	01-4112
12-24	0.161	7/16	01-4120	01-4121	01-4122
1/4-20	0.193	7/16	01-4140	01-4141	01-4142



## 2-Way Reversible Lock Nuts

Can be used from either side of nut. Low carbon steel. Zinc finish

UNC Size	Part Number	Pkg Qty
1/4-20	36-3153	100
5/16-18	36-3154	100
3/8-16	36-3155	100
7/16-14	36-3156	50
1/2-13	36-3157	50

Thickness same as Finished Hex Nuts.



## 3-Prong\* Tee Nuts

Insert threads in wood without counter-boring.

Drill hole to fit barrel size, then hammer in until flush.

Low carbon steel. Zinc finish.

Size	Barrel Diameter	Part Number	Pkg Qty
8-32	0.208"	03-222	100
10-24	0.243"	03-223	100
10-32 (NF)	0.243"	03-224	100
1/4-20	0.305"	03-225	100
5/16-18	0.375"	03-226	50
3/8-16	0.440"	03-227	50

\* Occasionally supplied with 4 or 6 prongs.



## Cap Nuts

(Acorn Nuts)

Low carbon steel. Zinc finish

Size	W.A.F.*	Part Number	Pkg
6-32	5/16	03-108	100
8-32	5/16	03-109	100
10-24	3/8	03-110	100
10-32 (NF)	3/8	03-111	100
1/4-20	7/16	03-112	100
5/16-18	9/16	03-113	100
3/8-16	5/8	03-114	100
1/2-13	3/4	03-115	50
5/8-11	15/16	03-116	25



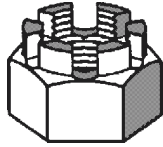

## Hex Castle Nuts

Low carbon steel. Zinc finish through 3/4" diameter.  
Fine thread (NF) only.

Size	Part Number	Pkg Qty
1/4-28	03-141	100
5/16-24	03-142	100
3/8-24	03-143	100
7/16-20	03-144	50
1/2-20	03-145	50
9/16-18	03-146	25
5/8-18	03-147	25
3/4-16	03-148	25
7/8-14	03-149	12
1"-14	03-150	12
1-1/8-12	03-151	1
1-1/4-12	03-152	1
1-1/2-12	03-153	1

*Width across flats same as Finished Hex Nuts.*

*\*For coarse thread sizes use Slotted Hex Nuts (UNC).*

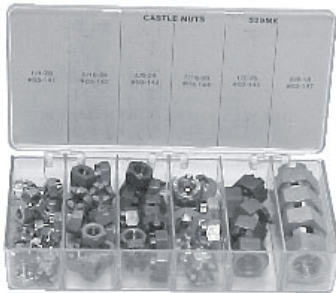

### NF CASTLE NUT MAINTENANCE KIT

6 SIZES, 1/4-28 THRU 5/8-18 IN A CLEAR POLYSTYRENE BOX. **PART NO. 529MK**

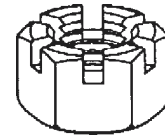

## Slotted Hex Nuts

Low carbon steel  
Zinc finish through 3/4" diameter

Size	Part Number		Pkg Qty
	UNC	UNF	
1/4	03-154	03-167	100
5/16	03-155	03-168	100
3/8	03-156	03-169	100
7/16	03-157	03-170	50
1/2	03-158	03-171	50
9/16	03-159	03-172	25
5/8	03-160	03-173	25
3/4	03-161	03-174	25
7/8	03-162	03-175	12
1"	03-163	03-176	12
1-1/8	03-164	03-177	1
1-1/4	03-165	03-178	1
1-1/2	03-166	03-179	1

*Width across flats same as Finished Hex Nuts.*



### NC SLOTTED HEX NUT MAINTENANCE KIT

6 SIZES, 1/4-20 THRU 5/8-11 COARSE THREAD, IN A CLEAR POLYSTYRENE BOX. **PART NO. 533MK**

### NF SLOTTED HEX NUT MAINTENANCE KIT

6 SIZES, 1/4-28 THRU 5/8-18 FINE THREAD, IN A CLEAR POLYSTYRENE BOX. **PART NO. 534MK**

*There are some things one can only achieve by a deliberate leap in the opposite direction. One has to go abroad in order to find the home one has lost.*

-Franz Kafka



Hex Nut dimensions on pg. 83



## Heavy Hex Full Nuts

Low carbon steel. Zinc finish.  
Coarse thread (NC) only.

Bolt Size <sup>1</sup>	W.A.F.*	Part Number	Pkg Qty
1/4-20	1/2	03-001	100
5/16-18	9/16	03-002	100
3/8-16	11/16	03-003	100
7/16-14	3/4	03-004	100
1/2-13	7/8	03-005	100
9/16-12	15/16	03-006	50
5/8-11	1-1/16	03-007	50
3/4-10	1-1/4	03-008	25
7/8-9	1-7/8	03-009	25
1"-8	1-5/8	03-010	25
1-1/8-7	1-13/16	03-011	10
1-1/4-7	2"	03-012	10
1-1/2-6	2-3/8	03-014	10

<sup>1</sup> Bolt size is also the approximate thickness dimension.



Grade 2H



Washer Faced

## Grade 2H Heavy Nuts

Heat treated steel for use with threaded studs on wheels and pipe flanges. Washer faced.  
Zinc finish to 1" diameter. Coarse thread (NC) only.

Bolt Size <sup>1</sup>	W.A.F.*	Part Number	Pkg Qty
1/4-20	1/2	03-021	100
5/16-18	9/16	03-022	100
3/8-16	11/16	03-023	100
7/16-14	3/4	03-024	100
1/2-13	7/8	03-025	100
9/16-12	15/16	03-026	50
5/8-11	1-1/16	03-027	50
3/4-10	1-1/4	03-028	25
7/8-9	1-7/8	03-029	25
1"-8	1-5/8	03-030	25
1-1/8-7	1-13/16	03-031	10
1-1/4-7	2"	03-032	10
1-1/8-8 <sup>2</sup>	1-13/16	03-035	10
1-1/4-8 <sup>2</sup>	2"	03-036	10
1-3/8-8 <sup>2</sup>	2-13/16	03-037	10
1-1/2-8 <sup>2</sup>	2-3/8	03-038	10

<sup>1</sup> Bolt size is also the approximate thickness dimension.

<sup>2</sup> -8 threads are normal B7 stud threads.



## Left Hand Hex Nuts

Low carbon steel. Plain finish  
Pkg: 1 each

Size	Part No.	
	UNC	UNF
1/4	03-181	03-194
5/16	03-182	03-195
3/8	03-183	03-196
7/16	03-184	03-197
1/2	03-185	03-198
9/16	03-186	03-199
5/8	03-187	03-200
3/4	03-188	03-201
7/8	03-189	03-202
1"	03-190	03-203
1-1/8	03-191	03-204
1-1/4	03-192	03-205
1-1/2	03-193	03-206

Width across flats same as Finished Hex Nuts.



## High Nuts

Low carbon steel. Plain finish. Fine thread (NF) only.

Size	Part Number	Thick-ness	Pkg Qty
3/8-24	03-083	17/32	100
7/16-20	03-084	19/32	100
1/2-20	03-085	11/16	100
9/16-18	03-086	3/4	50
5/8-18	03-087	27/32	50
3/4-16	03-088	1"	25
7/8-14	03-089	1-5/32	25
1"-14	03-090	1-5/16	25

Width across flats same as Finished Hex Nuts.

Hex Nut dimensions on pg. 83

\* W.A.F.: "Width Across Flats" (wrench size)



## Wing Nuts

Cold forged steel,  
Zinc finish.

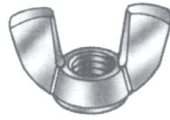

Size	Part Number		Pkg Qty
	UNC	UNF	
#6	03-118	-	100
#8	03-119	-	100
#10	03-120	03-129	100
1/4	03-122	03-130	100
5/16	03-123	-	100
3/8	03-124	-	100
7/16	03-125	-	50
1/2	03-126	-	50
5/8	03-127	-	25
3/4	03-128	-	25

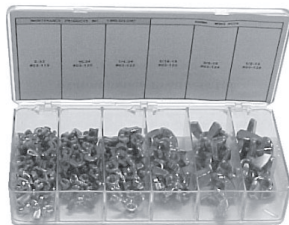

### WING NUT MAINTENANCE KIT

6 SIZES, 8-32, 10-24, 1/4-20, 5/16-18, 3/8-16 AND 1/2-13  
IN A CLEAR POLYSTYRENE BOX. **PART NO. 508MK**



## Carburetor Wing Nuts

Replaces most 1/4-20 OEM air cleaner nuts.  
Extruded steel with zinc finish.

Size	Part Number	Pkg
1/4-20 (NC)	03-258	50



## Pushnut Bolt Retainers

Use with coarse or fine thread bolts  
and studs. Plain finish.

Size	Part Number	Pkg
1/4	03-271	100
5/16	03-272	100
3/8	03-273	100
7/16	03-274	100
1/2	03-275	100



## Pal® Nuts

For threaded fasteners. Washer faced.  
Zinc finish.

Size	Flange	Part Number	Pkg
6-32	17/32	03-276	100
8-32	15/32	03-277	100
10-24	1/2	03-279	100
10-24	5/8	03-280	100
10-24	3/4	03-281	100
10-32 (NF)	1/2	03-282	100
1/4-20	19/32	03-283	100

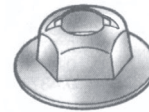

## Self Threading Nuts

Plain finish.

Size	Flange	Part Number	Pkg
1/8	17/32	03-284	100
5/32	9/16	03-285	100
3/16	5/8	03-286	100
1/4	19/32	03-287	100
.330	3/4	03-288	100



## Flat Push-on Retainers

For use with unthreaded fasteners.  
Zinc finish.

Size	Part Number	Pkg
1/16	03-243	100
3/32	03-244	100
1/8	03-245	100
5/32	03-246	100
3/16	03-247	100
.237	03-248	100
.240	03-249	100
1/4	03-250	100
5/16	03-251	100
3/8	03-252	100
1/2	03-253	100



# USS & SAE Flat Washers

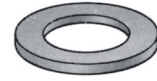
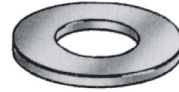
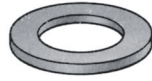
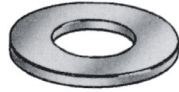

## USS Low Carbon Flat Washers

For Gr.2 or 5 Bolts  
Zinc Plated

## SAE Hardened Alloy Flat Washers

For Gr.5 or 8 Bolts  
Zinc Gold  
Dichromate Plated

## USS Hardened Alloy Flat Washers

For Gr.5 or 8 Bolts  
Zinc Gold  
Dichromate Plated

## SAE Grade 9 Alloy Flat Washers

For Gr.8 or 9 Bolts  
Zinc Gold  
Dichromate Plated

Size	Part No.	Pkg Qty	Part No.	Pkg Qty	Part No.	Pkg Qty	Part No.	Pkg Qty
3/16" (#10)	01-3000	100	-	-	-	-	-	-
	01-3001	300	-	-	-	-	-	-
	01-3002	1000	-	-	-	-	-	-
1/4"	01-3010	100	36-3010	100	34-3010	100	34-6010	200
	01-3011	300	36-3011	300	34-3011	300	-	-
	01-3012	1000	36-3012	1000	34-3012	1000	-	-
5/16"	01-3020	100	36-3020	100	34-3020	100	34-6020	100
	01-3021	300	36-3021	300	34-3021	300	-	-
	01-3022	1000	36-3022	1000	34-3022	1000	-	-
3/8"	01-3030	100	36-3030	100	34-3030	100	34-6030	100
	01-3031	300	36-3031	300	34-3031	300	-	-
	01-3032	1000	36-3032	1000	34-3032	1000	-	-
7/16"	01-3040	100	36-3040	100	34-3040	100	34-6040	50
	01-3041	300	36-3041	300	34-3041	300	-	-
	01-3042	1000	36-3042	1000	34-3042	1000	-	-
1/2"	01-3050	100	36-3050	100	34-3050	100	34-6050	50
	01-3051	300	36-3051	300	34-3051	300	-	-
	01-3052	1000	36-3052	1000	34-3052	1000	-	-
9/16"	01-3060	50	36-3060	50	34-3060	50	34-6060	50
	01-3061	150	36-3061	150	34-3061	150	-	-
5/8"	01-3070	50	36-3070	50	34-3070	50	34-6070	50
	01-3071	150	36-3071	150	34-3071	150	-	-
3/4"	01-3080	25	36-3080	25	34-3080	25	34-6080	40
	01-3081	100	36-3081	100	34-3081	100	-	-
7/8"	01-3090	25	36-3090	25	34-3090	25	34-6090	30
	01-3091	100	36-3091	100	34-3091	100	-	-
1"	01-3100	25	36-3100	25	34-3100	25	34-6100	20
	01-3101	100	36-3101	100	34-3101	100	-	-
1-1/8"	01-3110	25	36-3110	25	34-3110	25	34-6110	16
1-1/4"	01-3120	25	36-3120	25	34-3120	25	34-6120	12
1-1/2"	01-3140	25	36-3140	25	34-3140	25	-	-
1-3/4"	01-3150	25	-	-	-	-	-	-
2"	01-3160	25	-	-	-	-	-	-

**Flat washer dimensions on pg. 92**



## SAE Machine Screw Flat Washers

Low carbon steel. Zinc finish



Size	PART NUMBER		
	100 ea.	300 ea.	1000 ea.
4	02-0040	02-0041	02-0042
6	02-0060	02-0061	02-0062
8	02-0080	02-0081	02-0082
10	02-0100	02-0101	02-0102
12	02-0120	02-0121	02-0122



# Extra Thick Flat Washers



Extra thickness eliminates bolt failure caused by "dishing-out" of flat washers. Made from special high alloy steel and double heat-treated. Exceeds ASTM A325 and A490 specifications. Zinc gold dichromate finish.

Part Number	Bolt Size	Thickness	Pkg Qty
<b>U.S.S. EXTRA-THICK FLAT WASHERS</b>			
08-6010	1/4	.098	50
08-6020	5/16	.098	50
08-6030	3/8	.118	50
08-6040	7/16	.118	50
08-6050	1/2	.200	25
08-6060	9/16	.200	25
08-6070	5/8	.250	25
08-6080	3/4	.250	12
08-6090	7/8	.250	12
08-6100	1"	.250	12
<b>S.A.E. EXTRA-THICK FLAT WASHERS</b>			
08-3010	1/4	.086	50
08-3020	5/16	.086	50
08-3030	3/8	.118	50
08-3040	7/16	.118	50
08-3050	1/2	.200	25
08-3060	9/16	.200	25
08-3070	5/8	.250	25
08-3080	3/4	.250	12
08-3090	7/8	.250	12
08-3100	1"	.250	12

**Flat washer dimensions on pg. 92**



**EXTRA-THICK SAE FLAT WASHER ASSORTMENT**  
8 SIZES, 1/4" - 3/4" WASHERS IN A LARGE STEEL DRAWER. **PART NO. 16-0720**

**new** **U.S.S. EXTRA-THICK FLAT WASHER ASSORTMENT**  
8 SIZES, 1/4" - 3/4" WASHERS IN A LARGE STEEL DRAWER. **PART NO. 16-0820**

# Fender Washers

(Plaster Washers)

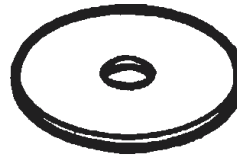

Low carbon steel oversized washers. - Zinc finish.

**STANDARD** 18 gauge (.050" thick) Use for electrical, plumbing, fixtures, drywall, plaster, etc.

**EXTRA-THICK** 14 gauge (.080" thick) Use for automotive use or anywhere a heavier washer is required.

Bolt Size	O.D. (In.)	I.D. (In.)	STANDARD (18 GA.)	EXTRA THICK (14 GA.)	Pkg Qty
1/8	9/16	5/32	03-1651	-	100
3/16	1-1/4	7/32	03-1652	03-311	100
1/4	1"	9/32	03-1653	03-312	100
1/4	1-1/4	9/32	03-1654	03-313	100
1/4	1-1/2	9/32	03-1655	03-314	100
1/4	2"	9/32	03-1656	-	100
5/16	1-1/4	11/32	03-1658	03-315	100
5/16	1-1/2	11/32	03-1659	03-316	100
3/8	1-1/4	13/32	03-1661	03-317	100
3/8	1-1/2	13/32	03-1662	03-318	100
3/8	2"	13/32	03-1663	-	100
1/2	2"	17/32	03-1666	03-319	100

# Finishing Washers

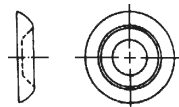

Countersunk

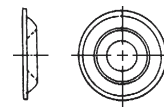

Flanged Countersunk



Raised, convex shape for use with 82° countersunk flat and oval head chrome screws. Nickel plated brass.

Size	Part Number	Pkg Qty
<b>COUNTERSUNK</b>		
#4	03-1048	100
#6	03-1049	100
#8	03-1050	100
#10	03-1051	100
#12	03-1052	100
#14	03-1053	100
<b>FLANGED COUNTERSUNK</b>		
#6	03-1054	100
#8	03-1055	100
#10	03-1056	100

# Machinery Bushings



Use machinery bushings to reduce friction and wear between moving parts, or as spacers between sprockets, pulleys and gears. Can be used in place of standard flat washers. Low carbon mild steel, plain finish.

Tolerances: ID: +0.010" to +0.025"; OD: +0.010" to -0.010".

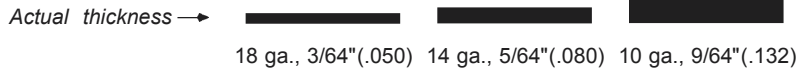

Inside Diameter	Outside Diameter	Part Number			Pkg Qty
		18 Ga. Thick	14 Ga. Thick	10 Ga. Thick	
<b>REGULAR MACHINERY BUSHINGS</b>					
1/2	7/8	20-169	20-203	-	50
9/16	15/16	20-202	20-204	-	50
5/8	1"	20-170	20-205	-	50
3/4	1-1/4	20-171	20-179	20-193	50
7/8	1-3/8	20-172	20-180	20-194	50
1"	1-1/2	20-173	20-181	20-195	50
1-1/8	1-3/4	20-174	20-182	20-196	50
1-1/4	1-7/8	20-175	20-183	20-197	50
1-3/8	2-1/8	20-176	20-184	20-198	25
1-1/2	2-1/4	20-177	20-185	20-199	25
1-5/8	2-3/8	-	20-186	20-207	25
1-3/4	2-1/2	20-178	20-187	20-200	25
1-7/8	2-7/8	-	20-188	20-208	25
2"	3"	-	20-189	20-201	25
2-1/8	3-1/8	-	20-190	20-209	10
2-1/4	3-1/4	-	20-191	20-210	10
2-3/8	3-3/8	-	20-206	20-211	10
2-1/2	3-1/2	-	20-192	20-212	10
<b>WIDE MACHINERY BUSHINGS</b>					
5/8	1-1/4	-	20-227	-	50
3/4	1-1/2	-	20-228	-	50
7/8	1-3/4	-	20-229	-	50
1"	2"	-	20-230	-	50
1-1/8	2-1/8	-	20-231	-	50
1-1/4	2-1/4	-	20-232	-	50
1-3/8	2-1/2	-	20-233	-	25
1-1/2	3"	-	20-234	-	25
1-3/4	3-1/4	-	20-235	-	25
2"	3-1/2	-	20-236	-	25

*Experience is the thing  
you have left when everything  
else is gone.*



## USS Flat Washer Dimensions

BoltSize	Washer I.D.	Washer O.D.	Minimum Thickness	Max. Thickness	Pcs Per Pound
3/16	1/4	9/16	.036	.065	361
1/4	5/16	3/4	.051	.080	149
5/16	3/8	7/8	.064	.104	87
3/8	7/16	1"	.064	.104	67
7/16	1/2	1-1/4	.064	.104	41
1/2	9/16	1-3/8	.086	.132	26
9/16	5/8	1-15/32	.086	.132	22
5/8	11/16	1-3/4	.108	.160	13
3/4	13/16	2"	.122	.177	9.1
7/8	15/16	2-1/4	.136	.192	6.5
1"	1-1/16	2-1/2	.136	.192	5.3
1-1/8	1-1/4	2-3/4	.136	.192	4.5
1-1/4	1-3/8	3"	.136	.192	3.8
1-1/2	1-5/8	3-1/2	.153	.213	2.6
1-5/8	1-3/4	3-3/4	.153	.213	2.3
1-3/4	1-7/8	4"	.153	.213	2

## SAE Flat Washer Dimensions

BoltSize	Washer I.D.	Washer O.D.	Minimum Thickness	Max. Thickness	Pcs Per Pound
#4	1/8	5/16	.036	.045	1650
#6	5/32	3/8	.036	.065	790
#8	3/16	7/16	.036	.065	585
#10	7/32	1/2	.036	.065	435
#12	1/4	9/16	.051	.080	280
1/4	9/32	5/8	.051	.080	222
5/16	11/32	11/16	.051	.080	192
3/8	13/32	13/16	.051	.080	140
7/16	15/32	59/64	.051	.080	105
1/2	17/32	1-1/16	.074	.121	55
9/16	19/32	1-5/32	.074	.121	43
5/8	21/32	1-5/16	.074	.121	36
3/4	13/16	1-15/32	.108	.160	22
7/8	15/16	1-3/4	.108	.160	16
1"	1-1/16	2"	.108	.160	12
1-1/8	1-1/4	2-1/4	.136	.192	9.5
1-1/4	1-5/16	2-1/2	.136	.192	6.25
1-1/2	1-9/16	3"	.136	.192	4.25

# Lock Washers

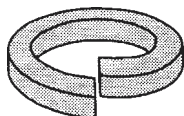

**Standard Split**  
for Grade 2 or 5  
Zinc Plated\*

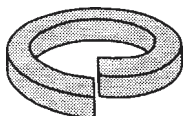

**Alloy Split**  
for Grade 8 Bolts  
Zinc Dichromate\*

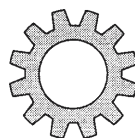

**External  
Shakeproof**  
Zinc Plated

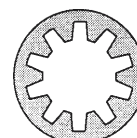

**Internal  
Shakeproof**  
Zinc Plated

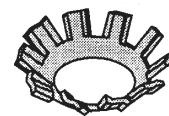

**Countersunk  
External**  
Zinc Plated

Size	Part No.	Pkg Qty	Part No.	Pkg Qty	Part No.	Pkg Qty	Part No.	Pkg Qty	Part No.	Pkg Qty
#4	01-0040	100	-	-	03-1000	100	03-1015	150	-	-
	01-0041	300	-	-	-	-	-	-	-	-
	01-0042	1000	-	-	-	-	-	-	-	-
#6	01-0060	100	-	-	03-1001	100	03-1016	100	03-5270	100
	01-0061	300	-	-	-	-	-	-	-	-
	01-0062	1000	-	-	-	-	-	-	-	-
#8	01-0080	100	-	-	03-1002	100	03-1017	100	03-5271	100
	01-0081	300	-	-	-	-	-	-	-	-
	01-0082	1000	-	-	-	-	-	-	-	-
#10 (3/16")	01-0100	100	-	-	03-1003	100	03-1018	100	03-5272	100
	01-0101	300	-	-	-	-	-	-	-	-
	01-0102	1000	-	-	-	-	-	-	-	-
#12	01-0120	100	-	-	03-1004	100	03-1019	100	-	-
	01-0121	300	-	-	-	-	-	-	-	-
	01-0122	1000	-	-	-	-	-	-	-	-
1/4	01-1010	100	34-1010	100	03-1005	100	03-1020	100	03-5274	100
	01-1011	300	34-1011	300	-	-	-	-	-	-
	01-1012	1000	34-1012	1000	-	-	-	-	-	-
5/16	01-1020	100	34-1020	100	03-1006	100	03-1021	100	03-5276	100
	01-1021	300	34-1021	300	-	-	-	-	-	-
	01-1022	1000	34-1022	1000	-	-	-	-	-	-
3/8	01-1030	100	34-1030	100	03-1007	100	03-1022	100	03-5278	100
	01-1031	300	34-1031	300	-	-	-	-	-	-
	01-1032	1000	34-1032	1000	-	-	-	-	-	-
7/16	01-1040	100	34-1040	100	03-1008	100	03-1023	100	-	-
	01-1041	300	34-1041	300	-	-	-	-	-	-
	01-1042	1000	34-1042	1000	-	-	-	-	-	-
1/2	01-1050	100	34-1050	100	03-1009	100	03-1024	100	-	-
	01-1051	300	34-1051	300	-	-	-	-	-	-
	01-1052	1000	34-1052	1000	-	-	-	-	-	-
9/16	01-1060	50	34-1060	50	03-1010	50	03-1025	50	-	-
	01-1061	150	34-1061	150	-	-	-	-	-	-
5/8	01-1070	50	34-1070	50	03-1011	50	03-1026	50	-	-
	01-1071	150	34-1071	150	-	-	-	-	-	-
3/4	01-1080	25	34-1080	25	03-1012	50	03-1027	50	-	-
	01-1081	100	34-1081	100	-	-	-	-	-	-
7/8	01-1090	25	34-1090	25	03-1013	50	03-1028	50	-	-
	01-1091	100	34-1091	100	-	-	-	-	-	-
1"	01-1100	25	34-1100	25	03-1014	50	03-1029	50	-	-
	01-1101	100	34-1101	100	-	-	-	-	-	-
1-1/8	01-1110	25	34-1110	25	-	-	-	-	-	-
1-1/4	01-1120	25	34-1120	25	-	-	-	-	-	-
1-1/2	01-1140	25	34-1140	25	-	-	-	-	-	-



\*Split Lock Washers are spring steel mechanically plated to reduce breakage from hydrogen embrittlement. All others electro-plated.





**STAR WASHER ASSORTMENT**  
24 SIZES, #6-5/8" INTERNAL AND EXTERNAL, IN A  
LARGE STEEL DRAWER. **PART NO. 16-0120**



**EXTERNAL STAR WASHER KIT**  
9 SIZES, #6-1/2" IN A CLEAR  
POLYSTYRENE BOX.  
**PART NO. 510MK**



**INTERNAL STAR WASHER KIT**  
9 SIZES, #6-1/2" IN A CLEAR  
POLYSTYRENE BOX.  
**PART NO. 551MK**

# Hi-Collar Split Lock Washers



Narrow design for use in counterbored holes with socket head cap screws or 12 point counterbore screws. Made from 1055 -1065 carbon steel. *Note: Smaller diameter than split lock washers. Washer O.D. is equal to the head diameter of socket hd. cap screws.*

Size	Part Number	Pkg Qty
#4	03-1030	100
#6	03-1031	100
#8	03-1032	100
#10	03-1034	100
1/4	03-1035	100
5/16	03-1036	100
3/8	03-1037	100
7/16	03-1038	100
1/2	03-1039	100
5/8	03-1041	50
3/4	03-1042	50
7/8	03-1043	25
1"	03-1044	25
1-1/4	03-1046	25

*Custom assortments are available on request.*

## WE STOCK CHAMPION CUTTING TOOLS



Ask for a free  
Champion catalog!

*Don't judge your wife  
too hard for her weaknesses.  
If she didn't have  
them, chances are she would  
never have married you.*



# Stainless Steel Hex Head Cap Screws

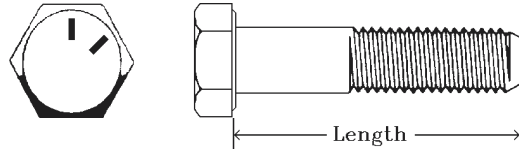

Type 18-8, 304 series stainless steel. Minimum tensile strength : 85,000 PSI  
 Temperature range: -300°F to +800°F. Nonmagnetic.

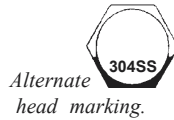
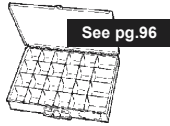

## 1/4" Diameter

Length	USS	SAE	Pkg Qty
	1/4-20	1/4-28	
1/2	22-182	22-284	100
3/4	22-183	22-285	100
1"	22-184	22-286	100
1-1/4	22-185	22-287	100
1-1/2	22-186	22-288	100
1-3/4	22-187	-	100
2"	22-188	22-289	100
2-1/4	22-189	-	50
2-1/2	22-190	22-290	50
2-3/4	22-191	-	50
3"	22-192	22-291	50
3-1/2	22-193	-	25
4"	22-194	-	25

## 3/8" Diameter

Length	USS	SAE	Pkg Qty
	3/8-16	3/8-24	
1/2	22-208	-	100
3/4	22-209	22-299	100
1"	22-210	22-300	100
1-1/4	22-211	22-301	100
1-1/2	22-212	22-302	100
1-3/4	22-213	22-303	50
2"	22-214	22-304	50
2-1/4	22-215	-	25
2-1/2	22-216	22-305	25
2-3/4	22-217	-	25
3"	22-218	-	25
3-1/2	22-219	-	25
4"	22-220	-	25
5"	22-221	-	25
6"	22-222	-	25

## 5/16" Diameter

Length	USS	SAE	Pkg Qty
	5/16-18	5/16-24	
1/2	22-195	22-292	100
3/4	22-196	22-293	100
1"	22-197	22-294	100
1-1/4	22-198	22-295	100
1-1/2	22-199	22-296	100
1-3/4	22-200	22-297	100
2"	22-201	22-298	50
2-1/4	22-202	-	50
2-1/2	22-203	-	50
2-3/4	22-204	-	50
3"	22-205	-	50
3-1/2	22-206	-	25
4"	22-207	-	25

## 7/16" Diameter

Length	USS	Pkg Qty
	7/16-14	
1"	22-223	50
1-1/4	22-224	50
1-1/2	22-225	50
1-3/4	22-226	25
2"	22-227	25
2-1/2	22-228	25
3"	22-229	25
4"	22-230	25

**Important — Apply Anti-Seize  
 Lubricant to stainless steel  
 bolt and nut assemblies!**

*(More information on pg. 100)*



Type 316 and other stainless steel alloys available upon special request



# Stainless Steel Hex Head Cap Screws

(Cont'd)

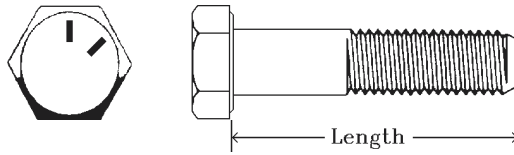

## 1/2" Diameter

Length	USS	SAE	Pkg Qty
	1/2-13	1/2-20	
3/4	22-231	-	50
1"	22-232	22-306	50
1-1/4	22-233	22-307	50
1-1/2	22-234	22-308	25
1-3/4	22-235	22-309	25
2"	22-236	22-310	25
2-1/4	22-237	22-311	25
2-1/2	22-238	22-312	25
2-3/4	22-239	22-313	25
3"	22-240	22-314	25
3-1/2	22-241	-	25
4"	22-242	-	25
4-1/2	22-243	-	25
5"	22-254	-	25
6"	22-255	-	25

## 3/4" Diameter

Length	USS	Pkg Qty
	3/4-10	
1"	22-270	25
1-1/4	22-271	25
1-1/2	22-272	25
1-3/4	22-273	25
2"	22-274	25
2-1/4	22-275	25
2-1/2	22-276	25
3"	22-277	25
3-1/2	22-278	25
4"	22-279	25
4-1/2	22-280	12
5"	22-281	12
5-1/2	22-282	12
6"	22-283	12

## 5/8" Diameter

Length	USS	SAE	Pkg Qty
	5/8-11	5/8-18	
1"	22-256	-	25
1-1/4	22-257	-	25
1-1/2	22-258	22-315	25
1-3/4	22-259	-	25
2"	22-260	22-316	25
2-1/4	22-261	-	25
2-1/2	22-262	22-317	25
3"	22-263	-	25
3-1/2	22-264	-	25
4"	22-265	-	25
4-1/2	22-266	-	25
5"	22-267	-	25
5-1/2	22-268	-	25
6"	22-269	-	25

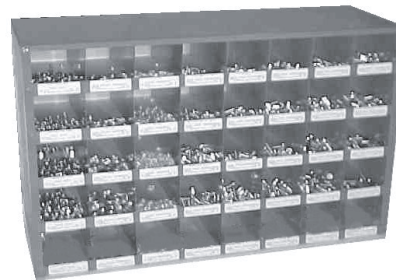

**T18-8 S/S HEX CAP SCREW ASSORTMENT**  
32 SIZES, 1/4" - 1/2" DIA. UP TO 3" LG. COARSE (NC) THREAD WITH NUTS & WASHERS, IN A 40-HOLE CABINET WITH 8 SPACES OPEN FOR EXPANSION. **PART NO. 40-111**



**T18-8 S/S HEX CAP SCREW ASSORTMENT**  
24 SIZES, 1/4" - 1/2" DIA. UP TO 2 1/2" LG. COARSE (NC) THREAD WITH NUTS & WASHERS, IN A LARGE STEEL DRAWER. **PART NO. 16-4924**

**Important — Apply Anti-Seize Lubricant to stainless steel bolt and nut assemblies!**

(More information on pg. 100)

Type 316 and other stainless steel alloys available upon special request



# Stainless Steel Socket Head Cap Screws



Type 18-8, 304 series stainless steel. Minimum tensile strength : 85,000 PSI. Nonmagnetic.

<b>#6 Diameter</b>				<b>1/4 " Diameter (Cont'd)</b>			
Length	USS 6-32		Pkg Qty	Length	USS 1/4-20	SAE 1/4-28	Pkg Qty
1/4	22-090		100	1-1/2	22-116	22-169	50
3/8	22-091		100	1-3/4	22-117	-	25
1/2	22-092		100	2"	22-118	-	25
5/8	22-093		100	<i>3/16" key size</i>			
3/4	22-094		100				
<i>7/64" key size</i>							
<b>#8 Diameter</b>				<b>5/16" Diameter</b>			
Length	USS 8-32		Pkg Qty	Length	USS 5/16-18	SAE 5/16-24	Pkg Qty
3/8	22-095		100	1/2	22-119	-	50
1/2	22-096		100	5/8	22-120	-	50
5/8	22-097		100	3/4	22-121	22-170	50
3/4	22-098		100	7/8	22-122	-	50
7/8	22-099		100	1"	22-123	22-171	50
1"	22-100		100	1-1/4	22-124	22-172	50
<i>9/64" key size</i>				1-1/2	22-125	22-173	25
				1-3/4	22-126	-	25
				2"	22-127	-	25
				2-1/4	22-128	-	25
				2-1/2	22-129	-	25
				<i>1/4" key size</i>			
<b>#10 Diameter</b>				<b>3/8" Diameter</b>			
Length	USS 10-24	SAE 10-32	Pkg Qty	Length	USS 3/8-16	SAE 3/8-24	Pkg Qty
3/8	22-101	22-156	100	1/2	22-130	-	50
1/2	22-102	22-157	100	3/4	22-131	22-174	50
5/8	22-103	22-158	100	7/8	22-132	-	50
3/4	22-104	22-159	100	1"	22-133	22-175	50
7/8	22-105	22-160	100	1-1/4	22-134	22-176	50
1"	22-106	22-161	100	1-1/2	22-135	22-177	25
1-1/4	22-107	22-162	50	1-3/4	22-136	-	25
1-1/2	22-108	22-163	50	2"	22-137	-	25
<i>5/32" key size</i>				2-1/4	22-138	-	25
				2-1/2	22-139	-	25
				<i>5/16" key size</i>			
<b>1/4" Diameter</b>							
Length	USS 1/4-20	SAE 1/4-28	Pkg Qty				
3/8	22-109	-	50				
1/2	22-110	22-164	50				
5/8	22-111	22-165	50				
3/4	22-112	22-166	50				
7/8	22-113	-	50				
1"	22-114	22-167	50				
1-1/4	22-115	22-168	50				

**Important — Apply Anti-Seize  
Lubricant to stainless steel  
bolt and nut assemblies!**

*(More information on pg. 100)*

*Length measured from under head.*



# Stainless Steel Socket Head Cap Screws



## 18-8 Stainless Steel Socket Head Cap Screws (Cont'd)

### 1/2" Diameter

Length	USS	SAE	Pkg Qty
	1/2-13	1/2-20	
3/4	22-140	-	25
7/8	22-141	-	25
1"	22-142	22-178	25
1-1/4	22-143	22-179	25
1-1/2	22-144	22-180	25
1-3/4	22-145	-	25
2"	22-146	22-181	25
2-1/4	22-147	-	25
2-1/2	22-148	-	25
3"	22-149	-	25

*3/8" key size*

### 5/8" Diameter

Length	USS	Pkg Qty
	5/8-11	
1-1/4	22-150	25
1-1/2	22-151	25
1-3/4	22-152	25
2"	22-153	25
2-1/2	22-154	25
3"	22-155	25

*1/2" key size*

*Length measured from under head.*

**Important — Apply Anti-Seize  
Lubricant to stainless steel  
bolt and nut assemblies!**

*(More information on pg. 100)*



## 18-8 Stainless Steel Flat Head Socket Cap Screws

Minimum tensile strength : 85,000 PSI. Nonmagnetic.

Size	Part No.	Pkg Qty
6-32 x 3/8	22-001	100
6-32 x 1/2	22-002	100
6-32 x 3/4	22-003	100
8-32 x 3/8	22-004	100
8-32 x 1/2	22-005	100
8-32 x 3/4	22-006	100
10-24 x 3/8	22-007	100
10-24 x 1/2	22-008	100
10-24 x 5/8	22-009	100
10-24 x 3/4	22-010	100
10-24 x 1"	22-011	100
10-32 x 3/8	22-030	100
10-32 x 1/2	22-031	100
10-32 x 5/8	22-032	100
10-32 x 3/4	22-033	100
10-32 x 1"	22-034	100
1/4-20 x 3/8	22-012	50
1/4-20 x 1/2	22-013	50
1/4-20 x 5/8	22-014	50
1/4-20 x 3/4	22-015	50
1/4-20 x 1"	22-016	50
1/4-20 x 1-1/4	22-017	50
5/16-18 x 1/2	22-018	50
5/16-18 x 5/8	22-019	50
5/16-18 x 3/4	22-020	50
5/16-18 x 1"	22-021	50
5/16-18 x 1-1/4	22-022	50
5/16-18 x 1-1/2	22-023	25
5/16-18 x 2"	22-024	25
3/8-16 x 3/4	22-025	50
3/8-16 x 1"	22-026	50
3/8-16 x 1-1/4	22-027	50
3/8-16 x 1-1/2	22-028	25
3/8-16 x 2"	22-029	25

*Length measured overall.*

# Stainless Steel Cup Point Set Screws



Type 18-8, 304 series stainless steel. Nonmagnetic.

*Length measured overall.*

Size	Part No.	Key Size	Pkg	Size	Part No.	Key Size	Pkg
4-40 x 1/8	22-035	.050"	100	3/8-16 x 5/16	22-071	3/16"	100
4-40 x 1/4	22-036	"	100	3/8-16 x 3/8	22-072	"	100
6-32 x 1/8	22-037	1/16"	100	3/8-16 x 1/2	22-073	"	100
6-32 x 3/16	22-038	"	100	3/8-16 x 5/8	22-074	"	100
6-32 x 1/4	22-039	"	100	3/8-16 x 3/4	22-075	"	50
6-32 x 5/16	22-040	"	100	3/8-16 x 1"	22-076	"	50
6-32 x 3/8	22-041	"	100	1/2-13 x 1"	22-080	1/4"	25
6-32 x 1/2	22-042	"	100				
8-32 x 1/8	22-043	5/64"	100				
8-32 x 3/16	22-044	"	100				
8-32 x 1/4	22-045	"	100				
8-32 x 5/16	22-046	"	100				
8-32 x 3/8	22-047	"	100				
8-32 x 1/2	22-048	"	100				
10-24 x 3/16	22-049	3/32"	100				
10-24 x 1/4	22-050	"	100				
10-24 x 5/16	22-051	"	100				
10-24 x 3/8	22-052	"	100				
10-24 x 1/2	22-053	"	100				
10-24 x 5/8	22-054	"	100				
10-24 x 3/4	22-055	"	100				
10-32 x 1/4	22-081	3/32"	100				
10-32 x 5/16	22-082	"	100				
10-32 x 3/8	22-083	"	100				
10-32 x 1/2	22-084	"	100				
1/4-20 x 3/16	22-056	1/8"	100				
1/4-20 x 1/4	22-057	"	100				
1/4-20 x 5/16	22-058	"	100				
1/4-20 x 3/8	22-059	"	100				
1/4-20 x 1/2	22-060	"	100				
1/4-20 x 5/8	22-061	"	50				
1/4-20 x 3/4	22-062	"	50				
1/4-20 x 1"	22-063	"	50				
1/4-28 x 1/4	22-086	1/8"	100				
1/4-28 x 5/16	22-087	"	100				
1/4-28 x 3/8	22-088	"	100				
1/4-28 x 1/2	22-089	"	100				
5/16-18 x 1/4	22-064	5/32"	100				
5/16-18 x 5/16	22-065	"	100				
5/16-18 x 3/8	22-066	"	100				
5/16-18 x 1/2	22-067	"	100				
5/16-18 x 5/8	22-068	"	50				
5/16-18 x 3/4	22-069	"	50				
5/16-18 x 1"	22-070	"	50				

*Sizes not shown may be available on special request, subject to minimum packaging.*

## Stainless Steel Button Socket Cap Screws



Type 18-8, 304 series stainless steel.

*Length measured from under head.*

Size	Part No.	Pkg
8-32 x 3/8	22-770	100
8-32 x 1/2	22-771	100
8-32 x 3/4	22-772	100
8-32 x 1"	22-773	100
10-24 x 3/8	22-774	100
10-24 x 1/2	22-775	100
10-24 x 3/4	22-776	100
10-24 x 1"	22-777	100
10-32 x 3/8	22-778	100
10-32 x 1/2	22-779	100
1/4-20 x 5/8	22-780	100
1/4-20 x 3/4	22-781	100
1/4-20 x 1"	22-782	100
5/16-18 x 5/8	22-783	100
5/16-18 x 3/4	22-784	100
5/16-18 x 1"	22-785	100
3/8-16 x 3/4	22-786	100
3/8-16 x 1"	22-787	100
3/8-16 x 1-1/4	22-788	100



# Stainless Steel Hex Nuts & Lock Washers



## 18-8 Stainless Steel Machine Screw Nuts\*

Size	Part No.	Pkg Qty
6-32	22-332	100
8-32	22-333	100
10-24	22-334	100
10-32	22-335	100
12-24	22-336	100

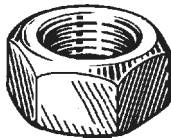

## Type 18-8 Stainless Steel Finished Hex Nuts\*

Size	USS Part No.	SAE Part No.	Pkg Qty
1/4	22-318	22-327	100
5/16	22-319	22-328	100
3/8	22-320	22-329	100
7/16	22-321	22-330	50
1/2	22-322	22-331	50
5/8	22-323	-	25
3/4	22-324	-	25
7/8	22-325	-	25
1"	22-326	-	25

***\*Important — Apply Anti-Seize Lubricant to stainless steel bolt and nut assemblies!***

**WARNING — If you use stainless steel fasteners, please read this...**

Failure to apply anti-seize lubricant to stainless steel bolt assemblies may result in breakage of the assembly. Be aware that friction and/or heat build-up<sup>1</sup> are the cause of surface galling during assembly. Galling is a common phenomenon on stainless assemblies that are left unlubricated. As many as 10% of the assemblies installed "dry" can possibly fail. Application of a quality anti-seize lubricant (we suggest Loctite 77164 Nickel Based Anti-Seize Lubricant) between the mating threads is a sure way to prevent surface galling<sup>2</sup>.

<sup>1</sup> Prevent heat build-up! When using a pneumatic wrench, it helps to reduce the tool speed to prevent any heat build-up during assembly. Heat causes friction, which can lead to surface galling.

<sup>2</sup> Where anti-seize lubricants are not allowed, use either stainless hex nuts of a different metallurgy, such as type 316 stainless, or use brass hex nuts instead.

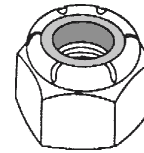

## 18-8 Stainless Steel Nylon Insert Lock Nuts\*

Size	USS Part No.	SAE Part No.	Pkg Qty
#6	22-337	-	100
#8	22-338	-	100
#10(3/16)	22-339	22-346	100
1/4	22-340	22-347	100
5/16	22-341	22-348	100
3/8	22-342	22-349	100
7/16	22-343	-	25
1/2	22-344	-	25
5/8	22-345	-	25

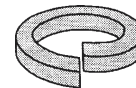

## 18-8 Stainless Steel Split Lock Washers

Size	Part No.	Pkg Qty
#6	22-368	100
#8	22-369	100
#10 (3/16)	22-370	100
#12	22-371	100
1/4	22-372	100
5/16	22-373	100
3/8	22-374	100
7/16	22-375	50
1/2	22-376	50
5/8	22-377	50
3/4	22-378	25
7/8	22-379	25
1"	22-380	25

*Note: smaller sizes may be slightly magnetic.*

**If men cannot agree on how to rule themselves, someone else must rule them.**

Theodore H. White

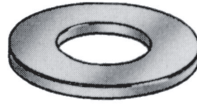

## Stainless Steel MS Flat Washers

Meets MS15795 military specifications. Type 18-8 stainless steel.

Bolt Size	Part No.	MS15795-Dash No.	I.D. Inches	O.D. Inches	THICKNESS		Pkg Qty
					Min.	Max.	
#6 SAE	22-350	-806	5/32	3/8	.036	.065	100
#8 SAE	22-351	-807	3/16	3/8	.036	.065	100
#8 USS	22-571	-841	3/16	7/16	.036	.065	100
#10	22-572	-808	7/32	7/16	.036	.065	100
#10 SAE	22-363	-842	7/32	1/2	.036	.065	100
#10 USS†	22-352	-809	1/4	9/16	.051	.080	100
1/4 SAE	22-364	-810	9/32	5/8	.051	.080	100
1/4 USS	22-354	-811	5/16	3/4	.051	.080	100
5/16 SAE	22-365	-812	11/32	11/16	.051	.080	100
5/16 USS	22-355	-813	3/8	7/8	.064	.104	100
3/8 SAE	22-366	-814	13/32	13/16	.051	.080	100
3/8 USS	22-356	-815	7/16	1"	.064	.104	100
7/16 SAE	22-573	-816	15/32	59/64	.051	.080	50
7/16 USS	22-357	-817	1/2	1-1/4	.064	.104	50
1/2 SAE	22-367	-818	17/32	1-1/16	.074	.121	50
1/2 USS	22-358	-819	9/16	1-3/8	.086	.132	50
5/8 USS	22-359	-821	11/16	1-3/4	.108	.160	50
3/4 USS	22-360	-823	13/16	2"	.122	.177	25
7/8 USS	22-361	-825	15/16	2-1/4	.136	.192	25
1" USS	22-362	-827	1-1/16	2-1/2	.136	.192	25

† #10 USS has same dimensions as #12 SAE washers.

Also available in type 316 series stainless steel washers, subject to minimum packaging.

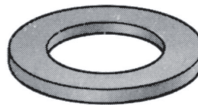

## Stainless Steel AN Flat Washers

Meets AN960 C aeronautics specifications. Type 18-8 stainless steel.

Bolt Size	Part No.	AN960-Dash No.	I.D. Inches	O.D. Inches	Thickness	Pkg Qty
8	22-575	-C8	.174	3/8	1/32	100
10	22-576	-C10	13/64	7/16	1/16	100
1/4	22-577	-C416	17/64	1/2	1/16	100
5/16	22-578	-C516	21/64	9/16	1/16	100
3/8	22-579	-C616	25/64	5/8	1/16	100
7/16	22-580	-C716	29/64	3/4	1/16	50
1/2	22-581	-C816	33/64	7/8	1/16	50



# 18-8 Stainless Steel Machine Screws

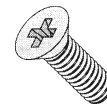
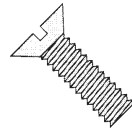
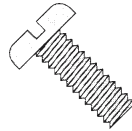
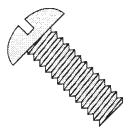

Size	Round Head Slotted.	Pan Head Slotted.	Flat Head Slotted..	Pan Head Phillips	Flat Head Phillips	Pkg Qty
6-32 x 1/4	22-381	22-586	-	22-679	22-724	100
6-32 x 3/8	22-382	22-587	22-440	22-680	22-725	100
6-32 x 1/2	22-383	22-588	22-441	22-681	22-726	100
6-32 x 3/4	22-384	22-589	22-442	22-682	22-727	100
6-32 x 1"	22-385	22-590	22-443	22-683	22-728	100
6-32 x 1-1/4	22-386	-	22-444	22-684	22-729	100
6-32 x 1-1/2	22-387	-	-	22-685	22-730	100
8-32 x 3/8	22-388	22-593	22-445	22-686	22-731	100
8-32 x 1/2	22-389	22-594	22-446	22-687	22-732	100
8-32 x 3/4	22-390	22-595	22-447	22-688	22-733	100
8-32 x 1"	22-391	22-596	22-448	22-689	22-734	100
8-32 x 1-1/4	22-392	-	22-449	22-690	22-735	100
8-32 x 1-1/2	22-393	-	-	22-691	22-736	100
8-32 x 2"	22-394	-	-	22-692	22-737	100
10-24 x 3/8	22-395	22-600	22-450	22-693	22-738	100
10-24 x 1/2	22-396	22-601	22-451	22-694	22-739	100
10-24 x 3/4	22-397	22-602	22-452	22-695	22-740	100
10-24 x 1"	22-398	22-603	22-453	22-696	22-741	100
10-24 x 1-1/4	22-399	-	22-454	22-697	22-742	100
10-24 x 1-1/2	22-400	-	22-455	22-698	22-743	100
10-24 x 1-3/4	22-401	-	-	-	-	100
10-24 x 2"	22-402	-	-	22-699	22-744	100
10-32 x 3/8	22-403	22-608	22-456	22-700	-	100
10-32 x 1/2	22-404	22-609	22-457	22-701	22-745	100
10-32 x 3/4	22-405	22-610	22-458	22-702	22-746	100
10-32 x 1"	22-406	22-611	22-459	22-703	22-747	100
10-32 x 1-1/4	22-407	-	22-460	22-704	22-748	100
10-32 x 1-1/2	22-408	-	22-461	22-705	22-749	100
10-32 x 1-3/4	22-409	-	-	22-706	22-750	100
10-32 x 2"	22-410	-	-	22-707	22-752	100
12-24 x 1/2	22-411	-	22-462	22-708	22-753	100
12-24 x 3/4	22-412	-	22-463	22-709	22-754	100
12-24 x 1"	22-413	-	22-464	22-710	22-755	100
12-24 x 1-1/4	22-414	-	-	-	-	100
12-24 x 1-1/2	22-415	-	-	-	-	100
1/4-20 x 3/8	22-416	-	-	-	-	100
1/4-20 x 1/2	22-417	22-622	22-465	22-711	22-756	100
1/4-20 x 3/4	22-418	22-623	22-466	22-712	22-757	100
1/4-20 x 1"	22-419	22-624	22-467	22-713	22-758	100
1/4-20 x 1-1/4	22-420	22-625	22-468	22-714	22-759	100
1/4-20 x 1-1/2	22-421	22-626	22-469	22-715	22-760	100
1/4-20 x 2"	22-422	-	22-470	22-716	22-761	50
1/4-20 x 2-1/2	22-423	-	22-471	22-717	22-762	50
1/4-20 x 3"	22-424	-	22-472	22-718	22-763	50
5/16-18 x 1/2	22-425	-	22-473	-	-	100
5/16-18 x 3/4	22-426	-	22-474	22-719	22-764	100
5/16-18 x 1"	22-427	-	22-475	22-720	22-765	100
5/16-18 x 1-1/4	22-428	-	22-476	22-721	22-766	50
5/16-18 x 1-1/2	22-429	-	22-477	22-722	22-767	50
5/16-18 x 2"	22-430	-	22-478	22-723	22-768	50
5/16-18 x 2-1/2	22-431	-	22-479	-	-	50
5/16-18 x 3"	22-432	-	22-480	-	-	50
3/8-16 x 3/4	22-433	-	-	-	-	100
3/8-16 x 1"	22-434	-	22-481	-	-	100
3/8-16 x 1-1/4	22-435	-	22-482	-	-	50
3/8-16 x 1-1/2	22-436	-	22-483	-	-	50
3/8-16 x 2"	22-437	-	22-484	-	-	50
3/8-16 x 2-1/2	22-438	-	22-485	-	-	50
3/8-16 x 3"	22-439	-	22-486	-	-	50

**S/S RD. HD. SLOTTED MACHINE SCREW ASSORTMENT**  
 24 SIZES, #6 - 1/4" DIA. UP TO 1 1/2" LG., WITH S/S HEX NUTS IN A  
 LARGE STEEL DRAWER. **PART NO. 16-2224**



# Stainless Steel Carriage Bolts



Type 18-8 , 304 series stainless steel

Size	Part No.	Pkg Qty
1/4-20 x 3/4	22-567	100
1/4-20 x 1"	22-568	100
1/4-20 x 1-1/4	22-569	100
1/4-20 x 1-1/2	22-570	100
1/4-20 x 2"	22-582	100
1/4-20 x 2-1/2	22-583	100
1/4-20 x 3"	22-584	100
1/4-20 x 4"	22-585	100
5/16-18 x 1"	22-591	100
5/16-18 x 1-1/4	22-592	100
5/16-18 x 1-1/2	22-597	100
5/16-18 x 2"	22-598	100
5/16-18 x 2-1/2	22-599	100
5/16-18 x 3"	22-604	100
5/16-18 x 4"	22-605	50
3/8-16 x 1"	22-769	100
3/8-16 x 1-1/4	22-606	100
3/8-16 x 1-1/2	22-607	100
3/8-16 x 2"	22-612	100
3/8-16 x 2-1/2	22-613	50
3/8-16 x 3"	22-614	50
3/8-16 x 4"	22-615	50
3/8-16 x 5"	22-616	50
3/8-16 x 6"	22-617	50
1/2-13 x 1-1/2	22-618	50
1/2-13 x 2"	22-619	50
1/2-13 x 2-1/2	22-620	50
1/2-13 x 3"	22-621	50
1/2-13 x 4"	22-676	25
1/2-13 x 5"	22-677	25
1/2-13 x 6"	22-678	25

VISIT OUR WEBSITE  
**mpi-online.com**  
 FAX ANYTIME!  
**219-696-6413**

# Stainless Steel Sheet Metal Screws

Type 18-8 , 304 series stainless steel  
 Type A point . Sharp threads  
 Pkg: 100 each

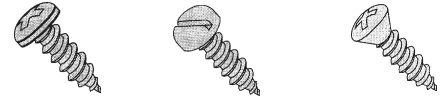

Size	Phillips Pan Hd.	Slotted Pan Hd.	Phillips Oval Hd.
4 x 1/4	22-645	22-487	-
4 x 3/8	22-646	22-488	-
4 x 1/2	22-647	22-489	-
4 x 3/4	22-648	22-490	-
6 x 1/4	22-649	22-491	-
6 x 3/8	22-650	22-492	-
6 x 1/2	22-651	22-493	22-627
6 x 3/4	22-652	22-494	22-628
6 x 1"	22-653	22-495	22-629
6 x 1-1/4	22-654	22-496	22-630
8 x 1/4	22-655	22-497	-
8 x 3/8	22-656	22-498	-
8 x 1/2	22-657	22-499	22-631
8 x 3/4	22-658	22-500	22-632
8 x 1"	22-659	22-501	22-633
8 x 1-1/4	22-660	22-502	22-634
8 x 1-1/2	22-661	22-503	22-635
10 x 3/8	22-662	22-504	-
10 x 1/2	22-663	22-505	22-636
10 x 5/8	22-664	22-506	-
10 x 3/4	22-665	22-507	22-638
10 x 1"	22-666	22-508	22-639
10 x 1-1/4	22-667	22-509	22-640
10 x 1-1/2	22-668	22-510	22-641
12 x 1/2	22-669	22-511	22-642
12 x 3/4	22-670	22-512	22-643
12 x 1"	22-671	22-513	22-644
14 x 1/2	22-672	22-514	-
14 x 3/4	22-673	22-515	-
14 x 1"	22-674	22-516	-
14 x 1-1/2	22-675	22-517	-



**S/S PAN HD. PHILLIPS SMS ASSORTMENT**  
 24 SIZES, #6 - 14 DIA. UP TO 1 1/2" LONG, IN A  
 LARGE STEEL DRAWER. **PART NO. 16-2324**

*Sizes not shown may be available on special request, subject to minimum packaging.*



# Stainless Steel Cotter Pins

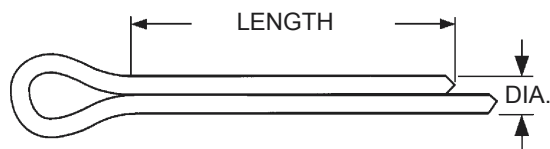

Type 304 stainless steel. Nonmagnetic\*

Size	Part No.	Pkg Qty
1/16 x 1/2	22-518	100
1/16 x 3/4	22-519	100
1/16 x 1"	22-520	100
1/16 x 1-1/2	22-521	100
1/16 x 2"	22-522	100
3/32 x 1-1/4	22-525	100
3/32 x 1-1/2	22-526	100
3/32 x 1-3/4	22-527	100
3/32 x 2"	22-528	100
1/8 x 1-1/4	22-530	100
1/8 x 1-1/2	22-531	100
1/8 x 1-3/4	22-532	100
1/8 x 2"	22-533	100
1/8 x 2-1/2	22-534	50
5/32 x 1"	22-535	100
5/32 x 1-1/2	22-536	50
5/32 x 2"	22-538	50
5/32 x 2-1/2	22-539	25
3/16 x 1"	22-540	100
3/16 x 1-1/2	22-541	50
3/16 x 2"	22-542	50
3/16 x 3"	22-544	25

\*Extremely small sizes may be slightly magnetic.

# Stainless Steel Square Key Stock

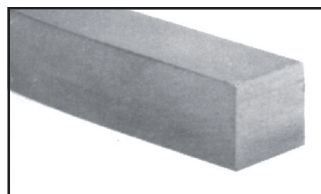

Type 304 stainless steel. Nonmagnetic  
Tolerance: ± .002"

Size	Part No.	Pkg Qty
1/8 x 12"	22-244	6
3/16 x 12"	22-245	6
1/4 x 12"	22-246	6
5/16 x 12"	22-247	6
3/8 x 12"	22-248	6
1/2 x 12"	22-249	4
5/8 x 12"	22-250	2
3/4 x 12"	22-251	2
7/8 x 12"	22-252	1
1" x 12"	22-253	1

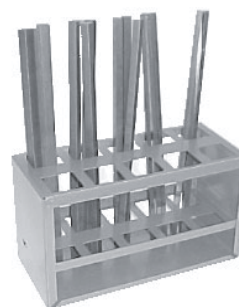

**15 PC. T304 STAINLESS KEY STOCK ASSORTMENT**  
5 SIZES, 1/8" - 1/2" SQUARE KEY STOCK (7/16" not included)  
IN STEEL KEY STOCK RACK. **PART NO. 22-751**

**KEY STOCK RACK ONLY**  
TEN 1 1/2" SQUARE COMPARTMENTS STORES KEY STOCK UP  
TO 12" LONG. WALL MOUNTABLE. SIZE: 10 1/2"W X 6"H X 5"D.  
Key Stock not included. **PART NO. 20-140**



**CALL US IF YOU NEED AN ITEM YOU CAN'T FIND IN THIS CATALOG...  
WE STOCK MANY ITEMS THAT ARE NOT LISTED!**



# Brass Hex Head Cap Screws

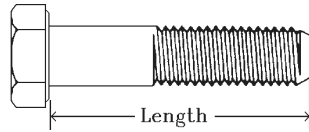

Length	Part No.	Pkg Qty
1/4-20 x 1/2	21-001	100
1/4-20 x 3/4	21-002	100
1/4-20 x 1"	21-003	100
1/4-20 x 1-1/4	21-004	100
1/4-20 x 1-1/2	21-005	100
1/4-20 x 1-3/4	21-006	100
1/4-20 x 2"	21-007	100
5/16-18 x 1/2	21-008	100
5/16-18 x 3/4	21-009	100
5/16-18 x 1"	21-010	100
5/16-18 x 1-1/4	21-011	100
5/16-18 x 1-1/2	21-012	100
5/16-18 x 1-3/4	21-013	100
5/16-18 x 2"	21-014	100
3/8-16 x 1/2	21-015	100
3/8-16 x 3/4	21-016	100
3/8-16 x 1"	21-017	100
3/8-16 x 1-1/4	21-018	100
3/8-16 x 1-1/2	21-019	100
3/8-16 x 1-3/4	21-020	100
3/8-16 x 2"	21-021	50
3/8-16 x 2-1/2	21-022	50
3/8-16 x 3"	21-023	50
3/8-16 x 4"	21-024	50
7/16-14 x 3/4	21-025	50
7/16-14 x 1"	21-026	50
7/16-14 x 1-1/4	21-027	50
7/16-14 x 1-1/2	21-028	50
7/16-14 x 1-3/4	21-029	50
7/16-14 x 2"	21-030	50
1/2-13 x 3/4	21-031	50
1/2-13 x 1"	21-032	50
1/2-13 x 1-1/4	21-033	50
1/2-13 x 1-1/2	21-034	25
1/2-13 x 1-3/4	21-035	25
1/2-13 x 2"	21-036	25
1/2-13 x 2-1/2	21-037	25
1/2-13 x 3"	21-038	25
1/2-13 x 3-1/2	21-039	25
1/2-13 x 4"	21-040	25

# Brass Hex Nuts



Size	USS (NC) Part No.	SAE (NF) Part No.	Pkg Qty
1/4	21-041	21-048	100
5/16	21-042	21-049	100
3/8	21-043	21-050	100
7/16	21-044	21-051	50
1/2	21-045	21-052	50
5/8	21-046	21-053	25
3/4	21-047	21-054	25

# Brass Machine Screw Nuts



Size	Part No.	Pkg Qty
4-40	21-055	100
6-32	21-056	100
8-32	21-057	100
10-24	21-058	100
10-32 (NF)	21-061	100
12-24	21-059	100
1/4-20	21-060	100

**Red Hot Deals!**

**Check out our current specials and new items on our website at <http://www.mpi-online.com>**



# Solid Brass Flat Washers

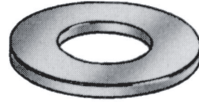

Part No.	Size	Trade Ref. #	Max I.D.	Max. O.D.	Approx. Thickness	Pkg Qty
21-062	4	-	.118"	9/32"	.025"	100
21-230	6	6S	.148"	5/16"	.028"	100
21-063	6	6L	.145"	3/8"	.032"	100
21-231	8	8S	.172"	3/8"	.032"	100
21-064	8	8L	.172"	7/16"	.036"	100
21-232	10 (3/16")	10S	.200"	7/16"	.036"	100
21-065	10 (3/16")	10L	.200"	1/2"	.040"	100
21-233	12	12S	.227"	1/2"	.040"	100
21-234	12	12L	.227"	9/16"	.040"	100
21-066	1/4"	14S	.260"	9/16"	.040"	100
21-067	1/4"	14L	.260"	11/16"	.050"	100
21-235	5/16"	20S	.336"	3/4"	.064"	100
21-068	5/16"	20L	.336"	7/8"	.064"	100
21-236	3/8"	24S	.395"	7/8"	.064"	100
21-069	3/8"	24L	.395"	1"	.081"	100
21-070	7/16"	-	1/2"	1-1/8"	.081"	100
21-071	1/2"	-	9/16"	1-1/4"	.091"	50
21-072	5/8"	-	11/16"	1-3/4"	.102"	25
21-073	3/4"	-	13/16"	1-7/8"	.114"	25

## Silicon Bronze Lock Washers

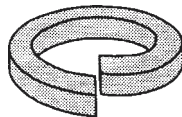

Size	Part No.	Pkg Qty
#4	21-074	100
#6	21-075	100
#8	21-076	100
#10 (3/16)	21-077	100
#12	21-078	100
1/4	21-079	100
5/16	21-080	100
3/8	21-081	100
7/16	21-082	50
1/2	21-083	50
5/8	21-084	25
3/4	21-085	25

LET US MAKE YOUR NEXT HOSE ASSEMBLY!

# DAYCO EASTMAN

HYDRAULIC AND  
AIR HOSES  
MADE IN HOUSE!



# Brass Slotted Machine Screws

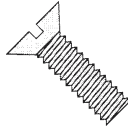
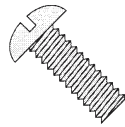

Size	Round Head Part No.	Flat Head Part No.	Pkg Qty
4-40 x 3/8	21-086	21-148	100
4-40 x 1/2	21-087	21-149	100
4-40 x 3/4	21-088	21-150	100
4-40 x 1"	21-089	-	100
6-32 x 1/4	21-090	21-151	100
6-32 x 3/8	21-091	21-152	100
6-32 x 1/2	21-092	21-153	100
6-32 x 3/4	21-093	21-154	100
6-32 x 1"	21-094	21-155	100
6-32 x 1-1/4	21-095	21-156	100
6-32 x 1-1/2	21-096	-	100
8-32 x 1/4	21-097	-	100
8-32 x 3/8	21-098	21-157	100
8-32 x 1/2	21-099	21-158	100
8-32 x 3/4	21-100	21-159	100
8-32 x 1"	21-101	21-160	100
8-32 x 1-1/4	21-102	21-161	100
8-32 x 1-1/2	21-103	21-162	100
8-32 x 2"	21-104	21-163	100
10-24 x 3/8	21-105	-	100
10-24 x 1/2	21-106	21-164	100
10-24 x 3/4	21-107	21-165	100
10-24 x 1"	21-108	21-166	100
10-24 x 1-1/4	21-109	21-167	100
10-24 x 1-1/2	21-110	21-168	100
10-24 x 1-3/4	21-111	-	100
10-24 x 2"	21-112	21-169	100
10-24 x 2-1/2	21-113	-	100
10-32 x 3/8	21-114	-	100
10-32 x 1/2	21-115	21-170	100
10-32 x 3/4	21-116	21-171	100
10-32 x 1"	21-117	21-172	100
10-32 x 1-1/4	21-118	21-173	100
10-32 x 1-1/2	21-119	21-174	100
10-32 x 1-3/4	21-120	-	100
10-32 x 2"	21-121	21-175	100
10-32 x 2-1/2	21-122	-	100

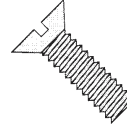
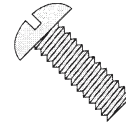

Size	Round Head Part No.	Flat Head Part No.	Pkg Qty
12-24 x 1/2	21-123	21-176	100
12-24 x 3/4	21-124	21-177	100
12-24 x 1"	21-125	21-178	100
12-24 x 1-1/4	21-126	21-179	100
12-24 x 1-1/2	21-127	-	100
12-24 x 1-3/4	21-128	-	100
12-24 x 2"	21-129	-	100
1/4-20 x 3/8	21-130	-	100
1/4-20 x 1/2	21-131	21-180	100
1/4-20 x 3/4	21-132	21-181	100
1/4-20 x 1"	21-133	21-182	100
1/4-20 x 1-1/4	21-134	21-183	100
1/4-20 x 1-1/2	21-135	21-184	100
1/4-20 x 1-3/4	21-136	21-185	50
1/4-20 x 2"	21-137	21-186	50
5/16-18 x 3/4	21-138	21-187	50
5/16-18 x 1"	21-139	21-188	50
5/16-18 x 1-1/4	21-140	21-189	50
5/16-18 x 1-1/2	21-141	21-190	50
5/16-18 x 2"	21-142	21-191	50
3/8-16 x 3/4	21-143	21-192	50
3/8-16 x 1"	21-144	21-193	50
3/8-16 x 1-1/4	21-145	-	50
3/8-16 x 1-1/2	21-146	21-194	50
3/8-16 x 2"	21-147	21-195	50



**BRASS RD. HD. SLOTTED MACHINE SCREW ASSORTMENT**  
 24 SIZES, #6-#14 DIA. UP TO 1 1/2" LG. WITH HEX NUTS  
 IN A LARGE STEEL DRAWER. **PART NO. 16-4524**

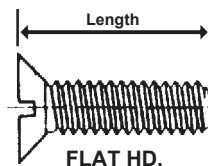
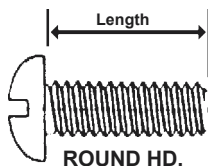

# Brass Flat Head Wood Screws

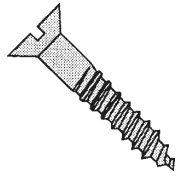

Sharp threads and points. 82° countersink.  
Made from solid brass. Slotted.

Size	Part No.	Pkg Qty
4 x 1/2	21-196	100
4 x 3/4	21-197	100
4 x 1"	21-198	100
6 x 1/2	21-199	100
6 x 3/4	21-200	100
6 x 1"	21-201	100
6 x 1-1/4	21-202	100
8 x 1/2	21-203	100
8 x 3/4	21-204	100
8 x 1"	21-205	100
8 x 1-1/4	21-206	100
8 x 1-1/2	21-207	100
8 x 1-3/4	21-208	100
8 x 2"	21-209	100
10 x 1/2	21-210	100
10 x 3/4	21-211	100
10 x 1"	21-212	100
10 x 1-1/4	21-213	100
10 x 1-1/2	21-214	100
10 x 1-3/4	21-215	100
10 x 2"	21-216	100
10 x 2-1/2	21-217	100
12 x 3/4	21-218	100
12 x 1"	21-219	100
12 x 1-1/4	21-220	100
12 x 1-1/2	21-221	100
12 x 2"	21-222	100
12 x 2-1/2	21-223	100
14 x 1"	21-224	100
14 x 1-1/4	21-225	100
14 x 1-1/2	21-226	100
14 x 1-3/4	21-227	100
14 x 2"	21-228	100
14 x 2-1/2	21-229	100

*Length measured overall.*

## I'M TIRED

I just found out why I feel tired all the time. We made a survey and found out I was doing more than my share of the world's work.

The population of the country is 160 million. But there are 62 million people over 60 years of age. That leaves 98 million to do the work. People under 21 years of age total 54 million, which leaves 44 million to do the work.

Then there are 21 million who are employed by the government, and that leaves 23 million to do the work. Ten million are in the Armed Forces— that leaves 13 million to do the work. Now deduct 12,800,000— the number in the State and city offices- and that leaves 200,000 to do the work. There are 126,000 in hospitals, insane asylums, and so forth— that leaves 74,000 people to do the work.

But 62,000 of these refuse to work, so that leaves 12,000 to do the work. Now it may interest you to know that there are 11,988 people in jail, so that leaves just two people to do all the work and that's you and me and I'm getting tired doing everything myself.

# Stainless Steel Facts & Tech Data

Provided as a general, nontechnical reference for common fastener usage.  
Consult a competent engineering reference for critical applications.

**Type 18-8, 304 Series Stainless Steel** is the most commonly used stainless steel available. Stainless steel is a corrosion resistant alloy steel containing mainly chromium, nickel, and silicon in various combinations, plus small percentages of titanium and vanadium. By AISI definition, a steel is called stainless when it contains at least 4% or more chromium. In the presence of oxygen<sup>1</sup>, these metals create a surface phenomenon known as *passivity*, forming an invisible film which protects the underlying metal from corrosion under severe environments. Further strengthening of this protective film is done through a cleaning process called *Passivating*. The passivation process dissolves ferrous particles and surface impurities. The stainless steel is then cleaned, lubricated, foreign substances are neutralized—increasing the corrosion resistance even further. The passivation process requires various oxidizing solutions, normally a nitric acid dip.

**Corrosion resistant**— Type 18-8 stainless steel protects against plant fumes, industrial contaminants<sup>2</sup>, agriculture chemicals, oxidation, salt spray, and abrasion wear caused by ice and blowing sand.

**Temperature resistant**— Type 18-8 stainless steel retains its physical properties under extreme temperature changes.

## Properties—Type 18-8 , 304 Series

Temperature range: -300°F to +800°F

Tensile strength: 85,000 PSI minimum

Workability: Cannot be hardened. Nonmagnetic in most cases. Some very small parts can be slightly magnetic.

**Application**— Use Type 18-8 stainless steel only where the elements or chemical corrosion is a factor. While other stainless steels may exceed the corrosion resistance, few can take the mechanical wear and abuse of

Type 18-8 stainless steel. Most often used where extensive welding and fabricating takes place. Do not specify type 18-8 stainless steel fasteners for applications requiring higher strength components such as SAE Grades 5 or 8 cap screws. The tensile strength of type 18-8 stainless screws (see *specifications*) is only comparable to that of low carbon steel SAE Grade 2 cap screws. Although type 18-8 stainless steel can seem difficult to drill or cut— do not assume it to be a high tensile strength fastening component.

**Cutting and drilling**— Most stainless steels are very abrasive resistant. This is the primary reason stainless steel is sometimes seems difficult to cut and drill.

**Drilling**— to drilling stainless steel, "Cobalt" steel drill bits work best, but only when a drill press is available. Cobalt drills are can easily break with the movement associated with portable electric drills. When a portable drill is absolutely necessary, special heavy duty drill bits work best (see *"Brute Drills"*). These drills are designed to drill most stainless steels and hardened alloys in both portable and fixed applications. They have specially designed precision cutting edges and a heavy duty web to withstand movement associated with portable drilling applications.

**Grinding**— When using high speed die grinders or chop saws to cut stainless steel parts, use a thin abrasive blade whenever possible. Die grinding wheels 1/16" thick or less are recommended. Chop saw wheels 3/32" thick or less are recommended. When surface grinding, use Zirconium based products (see *Flat Type 27 Zirconia Grinding Wheels and Big Cat™ Flap Discs*). Quality zirconium last longer and is an excellent choice for stainless and exotic steels.

**Sawing**— Use high speed Bi-metal steel saw blades, preferably with the variable tooth patterns now available. We stock these in band saw blades, hack saw blades and hole saws that will do the job.

See pg.110: **Galling of Stainless Steel Nuts and Bolts**

<sup>1</sup>NOTE: When oxygen is not present, such as in underground applications, the use of a brass or copper based fastener is recommended. Lack of oxygen to stainless steel or to the unexposed thread areas (between the assembled bolt and nut) of stainless steel will cause galling or "cold welding". Refer to page 110 for more information on installation and prevention of galling.

<sup>2</sup>ACID RESISTANCE: In the presence of "diluted" sulfuric acids, Type 316 stainless steel will perform well in most cases. For extremely severe environments, call us to special order "Carpenter 20" fasteners, a special alloy designed for extreme environments. Type 18-8, 304 series stainless is rated good, exposed to 95% pure sulfuric acid. Users' discretion is advised, and a test is recommended.

**SERVICE IS OUR PRIORITY! OUR COMMITMENT IS TO MEET YOUR NEEDS!**



# The Problem - Galling of Stainless Steel nuts and bolts.

*Reprinted from Industrial Fasteners Institute Fastener Standards, 6th Edition 1988*

## GALLING AND SEIZING

A frequent complaint about threaded fasteners is the problem of thread galling and seizing. Galling happens during fastener tightening. Seizing may happen in two ways. The first is a direct consequence of galling. The other (galling) occurs in service and is not a problem until disassembly is attempted.

### Galling

Thread galling seems to be the most prevalent with fasteners made of stainless steel aluminum, titanium and other alloys which self-generate an oxide surface film for corrosion protection. During fastener tightening as pressure builds between the contacting, and sliding, thread surfaces, protective oxides are broken, possibly wiped off, and interface metal high points shear or lock together. This cumulative clogging-shearing-locking action causes increasing adhesion. In the extreme, galling leads to seizing, the actual freezing together of the threads. If tightening is continued, the fastener can be twisted off or its threads ripped out.

There are various theories which explain the mechanism of galling and the apparent vulnerability of stainless steel and some of the non-ferrous alloys. Suffice it to say here that galling is a genuine problem and deserves the engineer's (and end user's) attention when considering the use of fasteners made of one of the more susceptible materials.

The following measures have been found helpful in relieving potential galling.

-Thread lubrication is the most effective. Among the more popular lubricants are those containing substantial amounts of molybdenum disulfide, graphite ("anti-seize compounds"), mica or talc, and some of the proprietary extreme pressure waxes. Another form of lubrication is silver and/or cadmium plating. The addition of a lubricant introduces other concerns. Torque-tension relationships are altered, if the lubricant is too "slippery," easier loosening under vibration is a possibility. Also, the compatibility of the lubricant with the service environment should be examined. Just as one simple example, stainless steel is frequently used in food processing equipment. The presence of an organic lubricant - and, certainly cadmium plating - could be a hazard.

-Parts of dissimilar alloys, and having different hardnesses, usually have less tendency to gall than mating parts of the same alloy. For example, the possibility of Type 416 stainless steel nuts galling when mated with Type 305 stainless steel bolts is less than if the nuts were of Type 303 stainless steel.

-The smoother the surface textures the less the frictional resistance. Rolled threads - the most common thread manufacturing practice for externally threaded fasteners in sizes 1 in. and smaller - are relatively smooth. External threads which are cut, and internal threads which are tapped, are considerably rougher. Unfortunately, there is no easy method for rolling internal threads.

-Heat contributes to the possibility of galling. High speed fastener installation and tightening generates heat. Lowering wrenching speeds can help reduce galling.



**When using stainless steel assemblies, lubricate threads with Loctite 77164 Nickel-Based Anti-Seize Lubricant (see page 386) OR use solid brass nuts instead of stainless steel nuts.**

# Metric 8.8 Hex Cap Screws



Property Class 8.8 heat treated medium carbon steel  
 Tensile strength; 116,000 psi minimum  
 Conforms to all ISO standards  
 Strength comparable to SAE Grade 5

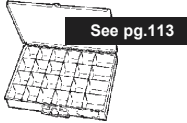
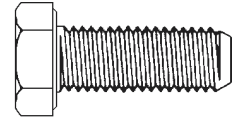

DIN 933- Fully threaded (coarse). DIN 931- Partly threaded (coarse)  
 DIN 961- Fully threaded (fine). DIN 960- Partly threaded (fine)  
 Part numbers followed by \* are fully threaded.  
*Length measured from under head.*

<b>M4</b>		
	<b>Coarse</b>	<b>Pkg Qty</b>
<b>Length</b>	<b>.7 Pitch</b>	
10	19-003*	100
12	19-004*	100
16	19-005*	100
20	19-006*	100
25	19-007*	100
30	19-008*	100
35	19-009	100
40	19-010	100

*Wrench size: 7mm*

<b>M7</b>		
	<b>Coarse</b>	<b>Pkg Qty</b>
<b>Length</b>	<b>1.0 Pitch</b>	
12	19-049*	100
16	19-050*	100
20	19-051*	100
25	19-052*	100
30	19-053*	100
35	19-054*	100
40	19-055*	100
45	19-056	100
50	19-057	100

*Wrench size: 11mm*

<b>M5</b>		
	<b>Coarse</b>	<b>Pkg Qty</b>
<b>Length</b>	<b>.8 Pitch</b>	
10	19-015*	100
12	19-016*	100
16	19-017*	100
20	19-018*	100
25	19-019*	100
30	19-020*	100
35	19-021	100
40	19-022	100
45	19-023	100
50	19-024	100

*Wrench size: 8mm*

<b>M8</b>			
	<b>Coarse</b>	<b>Fine</b>	<b>Pkg Qty</b>
<b>Length</b>	<b>1.25 Pitch</b>	<b>1.0 Pitch</b>	
10	19-071*	-	100
12	19-072*	-	100
16	19-073*	19-094*	100
20	19-074*	19-095*	100
25	19-075*	19-096*	100
30	19-076*	19-097*	100
35	19-077*	19-098*	100
40	19-078*	19-099*	100
45	19-079	19-100*	100
50	19-080	19-101*	100
55	19-081	-	100
60	19-082	19-103	100
65	19-083	-	100
70	19-084	-	100
75	19-085	-	50
80	19-086	-	50
90	19-087	-	50
100	19-088	-	50
110	19-089	-	50
120	19-090	-	50
130	19-091	-	50

*Wrench size: 13mm*

<b>M6</b>		
	<b>Coarse</b>	<b>Pkg Qty</b>
<b>Length</b>	<b>1.0 Pitch</b>	
10	19-030*	100
12	19-031*	100
16	19-032*	100
20	19-033*	100
25	19-034*	100
30	19-035*	100
35	19-036*	100
40	19-037*	100
45	19-038*	100
50	19-039*	100

*Wrench size: 10mm*



# Metric 8.8 Hex Cap Screws (cont'd)

## M10

Length	M10		Pkg Qty
	Coarse 1.5 Pitch	Fine 1.25 Pitch	
12	19-108*	-	100
16	19-109*	-	100
20	19-110*	19-132*	100
25	19-111*	19-133*	100
30	19-112*	19-134*	100
35	19-113*	19-135*	100
40	19-114*	19-136*	100
45	19-115*	19-137*	100
50	19-116	19-138*	100
55	19-117	-	100
60	19-118	19-140	100
65	19-119	-	100
70	19-120	19-142	100
75	19-121	-	50
80	19-122	19-144	50
85	19-123	-	50
90	19-124	-	50
100	19-125	-	50
110	19-126	-	50
120	19-127	-	50

Wrench size: 17mm

## M12

Length	M12			Pkg Qty
	Coarse 1.75 Pitch	Fine 1.5 Pitch	Extra Fine 1.25 Pitch	
16	19-146*	-	-	50
20	19-147*	19-172*	-	50
25	19-148*	19-173*	19-187*	50
30	19-149*	19-174*	19-188*	50
35	19-150*	19-175*	19-189*	50
40	19-151*	19-176*	19-190*	50
45	19-152*	19-177*	19-191*	50
50	19-153*	19-178*	19-192*	50
55	19-154*	19-179*	-	50
60	19-155	19-180*	19-194*	50
65	19-156	19-181	-	50
70	19-157	19-182	19-196	50
75	19-158	19-183	-	50
80	19-159	19-184	-	50
90	19-161	19-185	-	25
100	19-162	-	-	25
110	19-163	-	-	25
120	19-164	-	-	25
130	19-165	-	-	25
140	19-166	-	-	25
150	19-167	-	-	25
160	19-168	-	-	10
170	19-169	-	-	10
180	19-170	-	-	10
190	19-171	-	-	10

Wrench size: 19mm

## M14

Length	M14		Pkg Qty
	Coarse 2.0 Pitch	Fine 1.5 Pitch	
20	19-200*	-	25
25	19-201*	-	25
30	19-202*	19-225*	25
35	19-203*	-	25
40	19-204*	19-227*	25
45	19-205*	-	25
50	19-206	19-229*	25
60	19-208	19-231	25
65	19-209	19-232	25
75	19-211	-	25
80	19-212	-	25
90	19-214	-	25
100	19-215	-	25

Wrench size: 22mm

## M16

Length	M16		Pkg Qty
	Coarse 2.0 Pitch	Fine 1.5 Pitch	
25	19-240*	-	25
30	19-241*	19-268*	25
40	19-243*	19-270*	25
50	19-245*	19-272*	25
60	19-247*	19-274*	25
70	19-249	-	25
80	19-251	-	25
90	19-252	-	25
100	19-253	-	25

Wrench size: 24mm

Sizes not shown may be available on special request, subject to minimum packaging.

You know you are getting along in years when the girls at the office start to confide in you.



# Metric Cap Screw Assortments

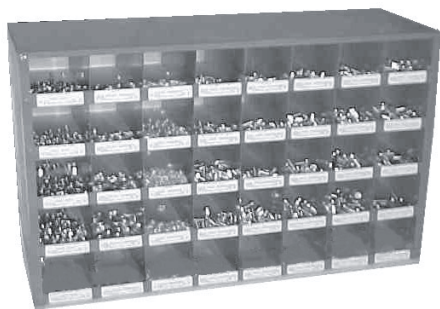

**METRIC 8.8 HEX HD. CAP SCREW ASSORTMENT**  
32 SIZES, M6 - M12 DIAMETER BOLTS, NUTS, FLATS AND LOCK WASHERS, IN A 40-HOLE STEEL BIN. **PART NO. 40-104**



**METRIC 8.8 HEX HD. CAP SCREW ASSORTMENT (SMALLER DIAMETERS)**  
24 SIZES, M4 - M7 DIA. BOLTS AND HEX NUTS IN A LARGE STEEL DRAWER. **PART NO. 16-2424**

**METRIC 10.9 ALLOY HEX HD. CAP SCREW ASSORTMENT**  
32 SIZES, M6 - M12 DIAMETER BOLTS, NUTS, FLATS AND LOCK WASHERS, IN A 40-HOLE STEEL BIN. **PART NO. 40-112**

**METRIC 8.8 HEX HD. CAP SCREW MAINTENANCE KIT**  
12 SIZES, M4 - M10 DIA. BOLTS, NUTS, & LOCK WASHERS, IN A CLEAR POLYSTYRENE BOX. **PART NO. 512MK**



**METRIC 8.8 CAP SCREW ASSORTMENT (LARGER DIAMETERS)**  
24 SIZES, M8 - M12 DIA. BOLTS AND HEX NUTS IN A LARGE STEEL DRAWER. **PART NO. 16-2524**

## Metric 10.9 Alloy Hex Cap Screws

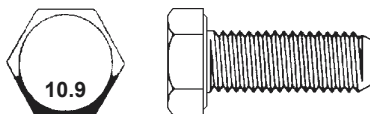

Property class 10.9 heat treated alloy steel. Minimum tensile strength: 150,000 psi. Strength comparable to SAE grade 8 specifications. Conforms to ISO standards. Coarse pitch only. Plain finish (unplated).

*Part numbers marked with bullet (•) DIN 933 fully thread, all others DIN 931 partly threaded.*

DIAMETER X THREAD PITCH

LENGTH	DIAMETER X THREAD PITCH					Pkg Qty
	M6 X 1.0	M8 X 1.0	M10 X 1.50	M12 X 1.75	M14 X 2.0	
16	19-1210•	19-1221•	—	—	—	100
20	19-1211•	19-1222•	19-1233•	—	—	100
25	19-1212•	19-1223•	19-1234•	19-1244•	—	100
30	19-1213	19-1224•	19-1235•	19-1245•	19-1285•	100
35	19-1214	19-1225	19-1236•	19-1246•	19-1286•	50
40	19-1215	19-1226	19-1237	19-1247•	19-1287•	50
45	19-1216	19-1227	19-1238	19-1248	19-1288•	50
50	19-1217	19-1228	19-1239	19-1249	19-1289	50
60	—	19-1229	19-1240	19-1250	19-1290	50
80	—	—	19-1241	19-1251	19-1291	50
100	—	—	19-1242	19-1252	19-1292	50
110	—	—	—	—	19-1293	50



# Metric Socket Head Cap Screws

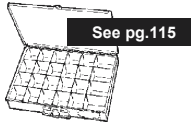

DIN 912-12. Property class 12.9 alloy steel (exceeds SAE Grade 8 specs.). Tensile strength 180,000 psi min.  
Conforms to all ISO standards. Coarse pitch only. Plain finish.

*Length measured from under head.*

<b>M4</b>		
<b>Length</b>	<b>Coarse .7 Pitch</b>	<b>Pkg Qty</b>
6	19-508	100
8	19-509	100
10	19-510	100
12	19-511	100
16	19-512	100
20	19-514	100

*Wrench size: 3mm*

<b>M5</b>		
<b>Length</b>	<b>Coarse .8 Pitch</b>	<b>Pkg Qty</b>
8	19-522	100
10	19-523	100
12	19-524	100
16	19-525	100
20	19-527	100
22	19-528	100
25	19-529	100
30	19-530	100
40	19-532	100
45	19-533	100

*Wrench size: 4mm*

<b>M6</b>		
<b>Length</b>	<b>Coarse 1.0 Pitch</b>	<b>Pkg Qty</b>
8	19-537	100
10	19-538	100
12	19-539	100
16	19-540	100
18	19-541	100
20	19-542	100
22	19-543	100
25	19-544	100
30	19-545	100
35	19-546	100
40	19-547	100
45	19-548	100
50	19-549	100
55	19-550	100
60	19-551	100

*Wrench size: 5mm*

<b>M8</b>		
<b>Length</b>	<b>Coarse 1.25 Pitch</b>	<b>Pkg Qty</b>
10	19-560	100
12	19-561	100
16	19-562	100
18	19-563	100
20	19-564	100
22	19-565	100
25	19-566	100
30	19-567	100
35	19-568	100
40	19-569	100
45	19-570	100
50	19-571	100
55	19-572	100
60	19-573	100
70	19-575	100
75	19-576	100
80	19-577	100

*Wrench size: 6mm*

<b>M10</b>		
<b>Length</b>	<b>Coarse 1.5 Pitch</b>	<b>Pkg Qty</b>
16	19-584	100
20	19-586	100
25	19-588	100
30	19-589	100
35	19-590	100
40	19-591	100
45	19-592	100
50	19-593	100
55	19-594	100
60	19-595	50
70	19-597	50
75	19-598	50
80	19-599	50

*Wrench size: 8mm*

*(Continued next page)*

# Metric Socket Head Cap Screws

(Cont'd)

<b>M12</b>	<b>Coarse</b>	<b>Pkg</b>
<b>Length</b>	<b>1.75 Pitch</b>	<b>Qty</b>
20	19-604	50
25	19-605	50
30	19-606	50
35	19-607	50
40	19-608	50
45	19-609	50
50	19-610	50
55	19-611	50
60	19-612	50
70	19-614	50
80	19-616	50
90	19-618	50
100	19-620	50

*Wrench size: 10mm*

<b>M14</b>	<b>Coarse</b>	<b>Pkg</b>
<b>Length</b>	<b>2.0 Pitch</b>	<b>Qty</b>
30	19-626	50
35	19-627	50
40	19-628	50
45	19-629	50
50	19-630	50
55	19-631	50
60	19-632	50
65	19-633	50

*Wrench size: 12mm*

<b>M16</b>	<b>Coarse</b>	<b>Pkg</b>
<b>Length</b>	<b>2.0 Pitch</b>	<b>Qty</b>
30	19-641	25
35	19-642	25
40	19-643	25
45	19-644	25
50	19-645	25
55	19-646	25
60	19-647	25
65	19-648	25
70	19-649	25

*Wrench size: 14mm*

**METRIC SOCKET HEAD  
CAP SCREW ASSORTMENT**  
24 SIZES, M4 - M12 DIAMETER,  
IN A LARGE STEEL DRAWER.  
PART NO. 16-2624



# Metric Flat Head Socket Cap Screws



DIN 7991-10. Property class 10.9 alloy steel. Tensile strength 150,000 psi minimum. Conforms to ISO standards. Plain finish.

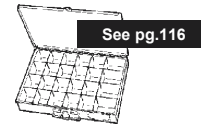

See pg.116

*Length measured overall.*

<b>M4</b>	<b>Coarse</b>	<b>Pkg</b>
<b>Length</b>	<b>.7 Pitch</b>	<b>Qty</b>
8	19-716	100
10	19-717	100
12	19-718	100
16	19-719	100
20	19-720	100

*Wrench size: 2.5mm*

<b>M5</b>	<b>Coarse</b>	<b>Pkg</b>
<b>Length</b>	<b>.8 Pitch</b>	<b>Qty</b>
8	19-723	100
10	19-724	100
12	19-725	100
16	19-726	100
20	19-727	100

*Wrench size: 3mm*

<b>M6</b>	<b>Coarse</b>	<b>Pkg</b>
<b>Length</b>	<b>1.0 Pitch</b>	<b>Qty</b>
8	19-730	100
10	19-731	100
12	19-732	100
16	19-733	100
20	19-734	100
25	19-735	100
30	19-736	100
35	19-737	100
40	19-738	100

*Wrench size: 4mm*

*(Continued next page)*



# Metric Flat Head Socket Cap Screws

(cont'd)

M8 Length	Coarse 1.25 Pitch	Pkg Qty
12	19-739	100
16	19-740	100
20	19-741	100
25	19-742	100
30	19-743	100
35	19-744	100
40	19-745	100

Wrench size: 5mm

M10 Length	Coarse 1.5 Pitch	Pkg Qty
12	19-746	100
16	19-747	100
20	19-748	100
25	19-749	100
30	19-750	100
35	19-751	100
40	19-752	100

Wrench size: 6mm

M12 Length	Coarse 1.75 Pitch	Pkg Qty
20	19-753	50
25	19-754	50
30	19-755	50
35	19-756	50
40	19-757	50
50	19-758	50

Wrench size: 8mm



**METRIC SOCKET HEAD CAP SCREW ASSORTMENT**  
24 SIZES, M4 - M12 DIAMETER, IN A LARGE STEEL DRAWER. **PART NO. 16-2724**

# Metric Socket Set Screws

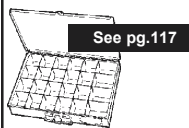

See pg.117



## Cup Point

DIN 916. Class 12.9 alloy (exceeds SAE Grade 8). Tensile strength 180,000 psi min. Conforms to all ISO standards Coarse pitch. Plain finish

*Length measured overall.*

M3 Length	Coarse .5 Pitch	Pkg Qty
4	19-1058	100
5	19-1059	100
6	19-1060	100
8	19-1061	100
10	19-1062	100

Wrench size: 1.5mm

M4 Length	Coarse .7 Pitch	Pkg Qty
4	19-1065	100
5	19-1066	100
6	19-1067	100
8	19-1068	100
10	19-1069	100
12	19-1070	100

Wrench size: 2mm

M5 Length	Coarse .8 Pitch	Pkg Qty
5	19-1073	100
6	19-1074	100
8	19-1075	100
10	19-1076	100
12	19-1077	100
16	19-1078	100

Wrench size: 2.5mm

M6 Length	Coarse 1.0 Pitch	Pkg Qty
6	19-1082	100
8	19-1083	100
10	19-1084	100
12	19-1085	100
16	19-1086	100
20	19-1087	100

Wrench size: 3mm

*(Continued next page)*

# Metric Socket Set Screws

(Cont'd)



M8 Length	Coarse 1.25 Pitch	Pkg Qty
8	19-1094	100
10	19-1095	100
12	19-1096	100
16	19-1097	100
20	19-1098	100
25	19-1099	100

Wrench size: 4mm

M10 Length	Coarse 1.5 Pitch	Pkg Qty
10	19-1105	100
12	19-1106	100
16	19-1107	100
20	19-1108	100
25	19-1109	100

Wrench size: 5mm

M12 Length	Coarse 1.75 Pitch	Pkg Qty
12	19-1115	100
16	19-1116	100
20	19-1117	100

Wrench size: 6mm



METRIC SOCKET SET SCREW ASSORTMENT, CUP POINT, 24 SIZES, M3 - M12 DIAMETER, IN A LARGE STEEL DRAWER. PART NO. 16-2824



# Metric Studs

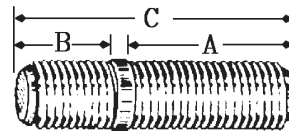

For cylinder heads and manifolds. DIN 939. Coarse pitch. Class 5.8 medium carbon steel. Plain finish.

Part Number	Diameter - Pitch	(A) Thread Length	(B) Thread Length	(C) Overall Length	Pkg Qty
19-1268	6-1.00	18	7.5	27.5	10
19-1269	6-1.00	18	7.5	32.5	10
19-1270	8-1.25	22	10	30	10
19-1271	8-1.25	22	10	35	10
19-1272	8-1.25	22	10	40	10
19-1273	8-1.25	22	10	45	10
19-1274	8-1.25	22	10	50	10
19-1275	8-1.25	22	10	65	10
19-1276	10-1.50	26	12	42	10
19-1277	10-1.50	26	12	47	10
19-1278	10-1.50	26	12	52	10
19-1279	10-1.50	26	12	62	5
19-1280	10-1.50	26	12	72	5
19-1281	12-1.75	30	15	45	5
19-1283	12-1.75	30	15	90	5

# Grade 8.8 Metric Threaded Rod



DIN 975-8. Heat-treated mild steel. Plain finish. Tensile strength: 113,000 PSI. Ref. ISO 898/1 1978. All coarse pitch. Length: 1 Meter (approx. 39")

Part Number	Thread Dia. x Pitch	Pkg Qty
99-113	M6 x 1.0	1
99-114	M8 x 1.25	1
99-115	M10 x 1.5	1
99-116	M12 x 1.75	1
99-117	M14 x 2.0	1
99-118	M16 x 2.0	1
99-119	M18 x 2.5	1
99-120	M20 x 2.5	1
99-121	M22 x 2.5	1
99-122	M24 x 3.0	1

Fine pitch threaded rod available upon special request.



# Metric Hex Key Wrenches & Sets



## BALL-END METRIC HEX KEYS

Ball end provides convenience of off-axis rotation.  
Long arm for high leverage. Made from 8650 alloy steel.

HEX SIZE	LENGTH	PART NO.	PKG. QTY
1.5	75	<b>29-348</b>	10
2	80	<b>29-349</b>	10
2.5	90	<b>29-350</b>	10
3	100	<b>29-351</b>	10
4	110	<b>29-352</b>	10
5	130	<b>29-353</b>	10
6	150	<b>29-354</b>	10
8	170	<b>29-355</b>	10
10	190	<b>29-356</b>	10



## SHORT ARM METRIC HEX KEYS

HEX SIZE	LENGTH	PART NO.	PKG. QTY
0.7	30	<b>7025</b>	10
0.9	30	<b>7026</b>	10
1.3	40	<b>7027</b>	10
1.5	50	<b>7028</b>	10
2	55	<b>7029</b>	10
2.5	60	<b>7030</b>	10
3	65	<b>7031</b>	10
4	72	<b>7032</b>	10
5	80	<b>7033</b>	10
6	90	<b>7034</b>	10
7	95	<b>7035</b>	10
8	100	<b>7036</b>	10
9	105	<b>7037</b>	10
10	112	<b>7038</b>	10
11	130	<b>7039</b>	5
12	125	<b>7040</b>	5
14	140	<b>7041</b>	5
17	160	<b>7042</b>	5
19	175	<b>7043</b>	5

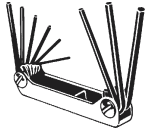

**7 PC. METRIC FOLDING  
HEX KEY SET**  
Sizes 1.5, 2, 2.5, 3, 4, 5, 6  
**Part no. 6816**

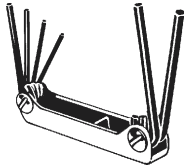

**6 PC. METRIC FOLDING  
HEX KEY SET**  
SIZES 4, 5, 6, 7, 8, 10  
**PART NO. 6817**

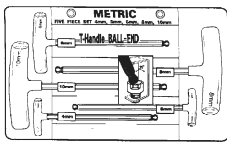

**5 PC. METRIC BALL END  
T-HANDLE HEX KEY SET**  
CUSHION GRIP HANDLES.  
SIZES 4, 5, 6, 8, 10  
**PART NO. 29-397**

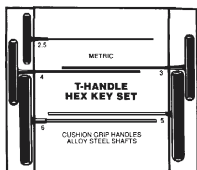

**5 PC. METRIC CHAMFERED  
T-HANDLE HEX KEY SET**  
CUSHION GRIP HANDLES.  
SIZES 2.5, 3, 4, 5, 6  
**PART NO. 29-395**

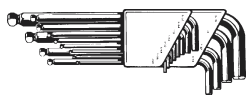

**9 PC. METRIC BALL END  
HEX KEY SET W/HOLDER**  
SIZES 1.5, 2, 2.5, 3, 4, 5, 6, 8, 10  
**PART NO. 29-393**



**9 PC. METRIC CHAMFERED  
HEX KEY SET W/HOLDER**  
SIZES 1.5, 2, 2.5, 3, 4, 5, 6, 8, 10  
**PART NO. 29-412**



## LONG ARM METRIC HEX KEYS

HEX SIZE	LENGTH	PART NO.	PKG. QTY
4	110	<b>7047</b>	10
5	130	<b>7048</b>	10
6	150	<b>7049</b>	10
8	170	<b>7051</b>	10
10	190	<b>7053</b>	10
12	250	<b>7055</b>	5

# Metric Hex Nuts

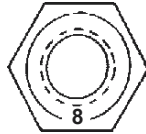

## Metric Class 8 Finished Hex Nuts

DIN 934. For use with class 8.8 fasteners

M3-14: low carbon steel

M16-24: heat treated low carbon steel

Diameter x Pitch	Coarse /Fine	W.A.F.	Thick- -ness	Part Number	Pkg Qty
M3 x .5	C	5.5	2.4	19-370	100
M4 x .7	C	7	3.2	19-371	100
M5 x .8	C	8	4.0	19-372	100
M6 x 1.0	C	10	5.0	19-373	100
M7 x 1.0	C	11	5.5	19-374	100
M8 x 1.25	C	13	6.5	19-375	100
M8 x 1.0	F	13	6.5	19-376	100
M10 x 1.5	C	17	8.0	19-377	100
M10 x 1.25	F	17	8.0	19-378	100
M10 x 1.0	F	17	8.0	19-379	100
M12 x 1.75	C	19	10	19-380	100
M12 x 1.5	F	19	10	19-381	100
M12 x 1.25	F	19	10	19-382	100
M14 x 2.0	C	22	11	19-383	100
M14 x 1.5	F	22	11	19-384	100
M16 x 2.0	C	24	13	19-385	100
M16 x 1.5	F	24	13	19-386	100
M18 x 2.5	C	27	15	19-387	100
M18 x 2.0	F	27	15	19-388	100
M20 x 2.5	C	30	16	19-389	50
M20 x 2.0	F	30	16	19-390	50
M22 x 2.5	C	32	18	19-391	25
M22 x 2.0	F	32	18	19-392	25
M24 x 3.0	C	36	19	19-393	25
M24 x 2.0	F	36	19	19-394	25

### METRIC CLASS 8.8 HEX NUT KIT

6 SIZES; M4 - M12 COARSE

THREAD, IN A CLEAR POLYSTYRENE

BOX. PART NO. 526MK



## Metric Class 10 Alloy Hex Nuts

Alloy steel for use with Class 10.9 alloy bolts. DIN 934. Plain finish.



Diameter x Pitch	Across Flats	Thick- -ness	Part Number	Pkg Qty
M6 x 1.0	10	5	19-1260	100
M8 x 1.25	13	6.5	19-1261	100
M10 x 1.5	17	8	19-1262	100
M12 x 1.75	19	10	19-1263	100
M14 x 2.0	22	11	19-1259	100



## Metric Hex Low Nuts

DIN 439. Plain finish

Diameter x Pitch	Coarse /Fine	W.A.F.	Thick- ness	Part Number	Pkg Qty
M4 x .7	C	7	2.2	19-395	100
M5 x .8	C	8	2.7	19-396	100
M6 x 1.0	C	10	3.2	19-397	100
M8 x 1.25	C	13	4	19-398	100
M8 x 1.0	F	13	4	19-399	100
M10 x 1.5	C	17	5	19-400	100
M10 x 1.0	F	17	5	19-402	100
M12 x 1.75	C	19	6	19-403	100
M12 x 1.5	F	19	6	19-404	100
M14 x 2.0	C	22	7	19-406	100
M14 x 1.5	F	22	7	19-407	100
M16 x 2.0	C	27	9	19-408	100

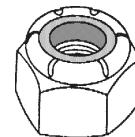

## Metric Nylon Insert Lock Nuts

DIN 985. Low carbon steel. Reusable.

Maximum temperature: 250°F. Zinc finish.

Diameter x Pitch	Coarse /Fine	W.A.F.	Thick- ness	Part Number	Pkg Qty
M3 x .5	C	5.5	4	19-418	100
M4 x .7	C	7	5	19-419	100
M5 x .8	C	8	5	19-420	100
M6 x 1.0	C	10	6	19-421	100
M8 x 1.25	C	13	8	19-422	100
M8 x 1.0	F	13	8	19-423	100
M10 x 1.5	C	17	10	19-424	100
M10 x 1.25	F	17	10	19-425	100
M10 x 1.0	F	17	10	19-426	100
M12 x 1.75	C	19	12	19-427	100
M12 x 1.5	F	19	12	19-428	100
M14 x 2.0	C	22	14	19-430	100
M16 x 2.0	C	24	16	19-432	100

**Custom Assortments  
Made to Your Specifications!**



# Metric Washers

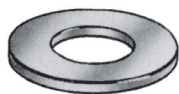

## Metric Flat Washers

DIN 125. Low carbon steel.  
M2 - M10 zinc plated, all other plain

Screw Size	ID	OD	Thick-ness	Part Number	Pkg Qty
2	2.2	4.5	.3	19-442	100
3	3.2	7.0	.5	19-443	100
4	4.3	9.0	.8	19-444	100
5	5.3	10	1.0	19-445	100
6	6.4	12	1.6	19-446	100
7	7.4	14	1.6	19-447	100
8	8.4	17	1.6	19-448	100
10	10.5	21	2.0	19-449	100
12	12.0	24	2.5	19-450	100
14	15.0	28	2.5	19-451	100
16	17.0	30	3.0	19-452	100
18	19.0	34	3.0	19-453	100
20	21.0	37	3.0	19-454	50
22	23.0	39	3.0	19-455	50
24	25.0	44	4.0	19-456	50

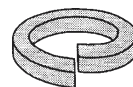

## Metric Lock Washers

DIN 127. Spring steel.  
For use with Class 8.8 or 10.9 fasteners

Screw Size	ID	OD	Part Number	Pkg Qty
3	3.1	6.2	19-457	100
4	4.1	7.6	19-458	100
5	5.1	9.2	19-459	100
6	6.1	11.8	19-460	100
7	7.1	12.8	19-461	100
8	8.1	14.8	19-462	100
10	10.2	18.1	19-463	100
12	12.2	21.1	19-464	100
14	14.2	24.1	19-465	100
16	16.2	27.4	19-466	100
18	18.2	29.4	19-467	100
20	20.2	33.6	19-468	50
22	22.5	35.9	19-469	50
24	24.5	40.0	19-470	50



## Metric Class 10 Hardened Flat Washers

Hardened steel. For use with Class 10.9 fasteners.  
Zinc finish

Size	I.D.	O.D.	Part Number	Pkg Qty
8	8.7	17.3	19-1265	100
10	10.3	20.5	19-1266	100
12	13.4	27	19-1267	100

**SAVE TIME BY LETTING US  
LOCATE THOSE HARD-TO-FIND  
ITEMS FOR YOU!**



## Metric Spring Washers

DIN 137. Spring steel. Plain finish.

Screw Size	ID	OD	Part Number	Pkg Qty
6	6.4	12	19-474	100
8	8.4	15	19-476	100
10	10.5	21	19-477	100
12	13.0	24	19-478	100

**Red Hot Deals!**

**Check out our current specials  
and new items on our website at  
<http://www.mpi-online.com>**

*Sizes not shown may be available on special request, subject to minimum packaging.*



# Metric Slotted Machine Screws

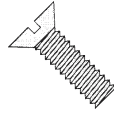

## Metric Flat Head Slotted Machine Screws

DIN 963. Low carbon steel. Zinc finish

*Length measured overall.*

<b>M3</b>	<b>Coarse</b>	<b>Pkg</b>
<b>Length</b>	<b>.5</b>	<b>Qty</b>
6	19-802	100
8	19-803	100
10	19-804	100
12	19-805	100
<b>M4</b>		
<b>Length</b>	<b>.7</b>	<b>Qty</b>
10	19-812	100
12	19-813	100
16	19-814	100
20	19-815	100
25	19-816	100
30	19-817	100
<b>M5</b>		
<b>Length</b>	<b>.8</b>	<b>Qty</b>
10	19-822	100
12	19-823	100
16	19-824	100
20	19-825	100
25	19-826	100
30	19-827	100
<b>M6</b>		
<b>Length</b>	<b>1.0</b>	<b>Qty</b>
10	19-834	100
12	19-835	100
16	19-836	100
20	19-837	100
25	19-838	100
30	19-839	100
35	19-840	100
40	19-841	100

*Sizes not shown may be available on special request,  
subject to minimum packaging.*

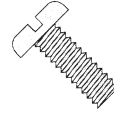

## Metric Pan Head Slotted Machine Screws

DIN 85. Low carbon steel. Zinc finish

*Length measured from under head.*

<b>M3</b>	<b>Coarse</b>	<b>Pkg</b>
<b>Length</b>	<b>.5</b>	<b>Qty</b>
6	19-764	100
8	19-765	100
10	19-766	100
12	19-767	100
16	19-768	100
20	19-769	100
25	19-770	100
30	19-771	100
<b>M4</b>		
<b>Length</b>	<b>.7</b>	<b>Qty</b>
8	19-772	100
10	19-773	100
12	19-774	100
16	19-775	100
20	19-776	100
25	19-777	100
30	19-778	100
35	19-779	100
40	19-780	100
50	19-781	100
<b>M5</b>		
<b>Length</b>	<b>.8</b>	<b>Qty</b>
10	19-782	100
12	19-783	100
16	19-784	100
20	19-785	100
25	19-786	100
30	19-787	100
35	19-788	100
40	19-789	100
50	19-790	100
<b>M6</b>		
<b>Length</b>	<b>1.0</b>	<b>Qty</b>
10	19-791	100
12	19-792	100
16	19-793	100
20	19-794	100
25	19-795	100
30	19-796	100
35	19-797	100
40	19-798	100
50	19-799	100



# Metric Phillips Pan Head Machine Screws



DIN 7985. Low carbon steel. Zinc finish  
*Length measured from under head.*

<b>M3</b>	<b>Coarse</b>	<b>Pkg</b>
<b>Length</b>	<b>.5</b>	<b>Qty</b>
5	19-916	100
6	19-917	100
8	19-918	100
10	19-919	100
12	19-920	100
16	19-921	100
18	19-922	100
20	19-923	100
25	19-925	100
30	19-926	100

<b>M4</b>	<b>Coarse</b>	<b>Pkg</b>
<b>Length</b>	<b>.7</b>	<b>Qty</b>
6	19-927	100
8	19-928	100
10	19-929	100
12	19-930	100
16	19-931	100
18	19-932	100
20	19-933	100
25	19-935	100
30	19-936	100
35	19-937	100
40	19-938	100

<b>M5</b>	<b>Coarse</b>	<b>Pkg</b>
<b>Length</b>	<b>.8</b>	<b>Qty</b>
8	19-939	100
10	19-940	100
12	19-941	100
16	19-942	100
18	19-943	100
20	19-944	100
25	19-946	100
30	19-947	100
35	19-948	100
40	19-949	100
45	19-950	100
50	19-951	100

<b>M6</b>	<b>Coarse</b>	<b>Pkg</b>
<b>Length</b>	<b>1.0</b>	<b>Qty</b>
10	19-952	100
12	19-953	100
16	19-954	100
20	19-955	100
25	19-956	100
30	19-957	100
35	19-958	100
40	19-959	100
45	19-960	100
50	19-961	100

<b>M8</b>	<b>Coarse</b>	<b>Pkg</b>
<b>Length</b>	<b>1.25</b>	<b>Qty</b>
16	19-962	100
20	19-963	100
25	19-964	100
30	19-965	100
40	19-966	100
50	19-967	100



**METRIC PHILLIPS PAN HEAD  
 MACHINE SCREW ASSORTMENT**  
 24 SIZES, M3 - M8 DIA., IN A LARGE STEEL DRAWER.  
**PART NO. 16-2924**



*Sizes not shown may be available on special request, subject to minimum packaging.*

# HSS Metric Plug Taps



Universal "plug" style. High speed steel. Ground threads.

PART NO.	TAP SIZE (MM)	THREAD PITCH	COARSE / FINE	NO. OF FLUTES	THREAD D-LIMIT	USE DRILL	PKG QTY
50-800	3	0.50	C	3	3	No. 40	12
50-801	4	0.70	C	4	4	No. 30	12
50-802	5	0.80	C	4	4	No. 20	12
50-803	6	1.00	C	4	5	No. 9	12
50-804	8	1.25	C	4	5	Ltr. I	6
50-811	8	1.00	F	4	5	Ltr. J	6
50-805	10	1.50	C	4	6	Ltr. Q	6
50-812	10	1.25	F	4	5	Ltr. S	6
50-806	12	1.75	C	4	6	Ltr. X	6
50-807	14	2.00	C	4	7	15/32"	1
50-808	16	2.00	C	4	7	35/64"	1
50-809	18	2.50	C	4	7	39/64"	1
50-810	20	2.50	C	4	7	11/16"	1

## Metric "O" Ring Kit



**METRIC "O" RING MAINTENANCE KIT**  
BUNA N RUBBER, 36 SIZES; M5.4 - M24 OD. IN A POLYPROPYLENE BOX. **PART NO. AV-15961**

*\*See Auveco Products catalog for individual sizes.*

## Metric Grease Fittings

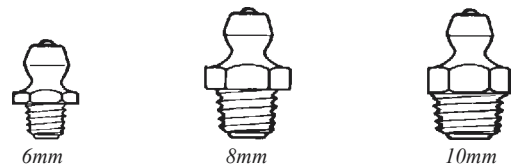

### STRAIGHT

Part No.	Dia. x Pitch	Pkg
3110 .....	M6 x 1.0 .....	50
3114 .....	M8 x 1.0 .....	50
3117 .....	M10 x 1.0 .....	50

### 45° ELBOW

Part No.	Dia. x Pitch	Pkg
3112 .....	M6 x 1.0 .....	25
3115 .....	M8 x 1.0 .....	25
3118 .....	M10 x 1.0 .....	25

### 90° ELBOW

Part No.	Dia. x Pitch	Pkg
3113 .....	M6 x 1.0 .....	25
3116 .....	M8 x 1.0 .....	25
3119 .....	M10 x 1.0 .....	25



**METRIC GREASE FITTING MAINTENANCE KIT**  
9 SIZES; M6, M8 & M10 DIA., IN A CLEAR POLYSTYRENE BOX. **PART NO. 522MK**



# Metric Tap-Drill Sizes

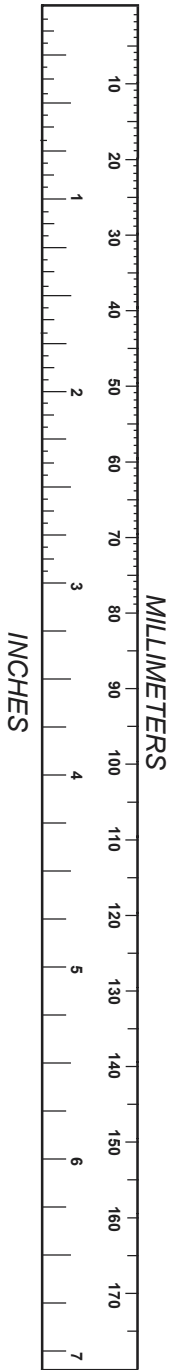

DIAMETER x PITCH	COARSE /FINE	RECOMMENDED TAP-DRILL SIZE	NEAREST EQUIVALENT TAP-DRILL SIZE
M2 x 0.4	C	1.6 mm (.0630")	1/16" (.0625")
M2.5 x 0.45	C	2.05 mm (.0807")	#46 (.0810")
M3 x 0.5	C	2.5 mm (.0984")	#40 (.0980")
M4 x 0.7	C	3.4 mm (.1339")	#30 (.1285")
M5 x 0.8	C	4.2 mm (.1654")	#20 (.1610")
M6 x 1.0	C	5 mm (.1969")	#9 (.1960")
M7 x 1.0	C	6 mm (.2362")	15/64" (.2344")
M8 x 1.25	C	6.9" (.2717")	Ltr. I (.2720")
M8 x 1.0	F	7.1 mm (.2795")	Ltr. J (.2770")
M10 x 1.5	C	8.5 mm (.3346")	Ltr. Q (.3320")
M10 x 1.25	F	8.9 mm (.3504")	Ltr. S (.3480")
M10 x 1.0	F	9.1 mm (.3583")	Ltr. T (.3580")
M12 x 1.75	C	10.2 mm (.4015")	Ltr. X (.3970")
M12 x 1.5	F	10.5 mm (.4134")	Ltr. Z (.4130")
M12 x 1.25	F	11 mm (.4331")	27/64" (.4219")
M14 x 2.0	C	12 mm (.4724")	15/32" (.4688")
M14 x 1.5	F	12.5 mm (.4921")	31/64" (.4844")
M14 x 1.25	F	12.8 mm (.5039")	1/2" (.5000")
M16 x 2.0	C	14 mm (.5512")	35/64" (.5469")
M16 x 1.5	F	14.7 mm (.5787")	37/64" (.5781")
M18 x 2.5	C	15.5 mm (.6102")	39/64" (.6094")
M18 x 1.5	F	16.8 mm (.6614")	21/32" (.6562")
M20 x 2.5	C	17.5 mm (.6890")	11/16" (.6875")
M22 x 2.5	C	19.5 mm (.7677")	49/64" (.7656")
M24 x 3.0	C	21 mm (.8268")	53/64" (.8281")
M24 x 2.0	F	22.3 mm (.8779")	7/8" (.8750")

## METRIC CONVERSION FORMULAS

Use the rule shown to the left for a quick reference, or for an accurate conversion use one of the following formulas.

INCHES TO MILLIMETERS ..... MULTIPLY KNOWN DECIMAL INCHES X 25.4  
 MILLIMETERS TO INCHES ..... MULTIPLY KNOWN MILLIMETERS X .03937

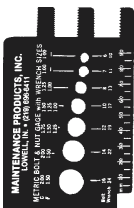

## Metric Bolt Gauge

Plastic sizer measures diameters, thread pitches and wrench sizes.

Part No. 42-003



## Metric Pitch Gage

Accurately measures 24 pitch sizes from .25mm - 6mm.

Part No. 7070

# Metric Cap Screw Torque Guide

These tables are an estimate of torque required to induce corresponding clamp load in a bolt for noncritical nut and bolt assemblies, not tapped holes. You should consult a qualified engineer for critical applications since many variables affect final assembly torque. *For plated nut and bolt assemblies only†.*

## COARSE PITCH

PROPERTY CLASS	TORQUE Ma	NOMINAL DIAMETER X COARSE PITCH													
		3x.5	4x.7	5x.8	6x1	7x1	8x1.25	10x1.5	12x1.75	14x2	16x2	18x2.5	20x2.5	22x2.5	24x3.0
5.6	Nm	0.56	1.28	2.5	4.3	7.1	10.5	21	36	58	88	121	171	230	295
	ft. lb.	0.41	0.94	1.84	3.1	5.2	7.7	15	26	42	64	89	126	169	217
8.8	Nm	1.28	2.9	5.75	9.9	16.5	24	48	83	132	200	275	390	530	675
	ft. lb.	0.94	2.14	4.24	7.3	12.1	17.7	35	61	97	147	202	287	390	497
10.9	Nm	1.8	4.1	8.1	14	23	34	67	117	185	285	380	550	745	960
	ft. lb.	1.33	3.02	5.97	10.3	16.9	25	49	86	136	210	287	405	549	708
12.9	Nm	2.15	4.95	9.7	16.5	27	40	81	140	220	340	470	660	890	1140
	ft. lb.	1.59	3.65	7.15	12.1	19.9	29	59	103	162	250	346	486	656	840

## FINE PITCH

PROPERTY CLASS	TORQUE Ma	NOMINAL DIAMETER X FINE PITCH								
		8x1	10x1.25	12x1.25	14x1.5	16x1.5	18x1.5	20x1.5	22x1.5	24 x2.0
8.8	Nm	25	49	88	140	210	305	425	570	720
	ft. lb.	18	36	64	103	154	224	313	420	531
10.9	Nm	35	68	125	195	295	425	600	800	1000
	ft. lb.	25	50	92	143	217	313	442	590	737
12.9	Nm	42	82	150	235	350	510	720	960	1200
	ft. lb.	30	60	110	173	258	376	531	708	885

### TORQUE CONVERSION FORMULAS

FOOT POUNDS to INCH POUNDS ..... Multiply known *Ft. Lbs.* x 12.0  
 FOOT POUNDS to NEWTON METERS ..... Multiply known *Ft. Lbs.* x 1.355818  
 NEWTON METERS to FOOT POUNDS ..... Multiply known *Nm* x 0.7375621

### † TORQUE ADJUSTMENTS

Torque values for *unplated assemblies* (plain steel, dry and unlubricated) should be increased by 33%.  
 Torque values for *lubricated assemblies* (oil, grease, anti-seize) should be reduced by 45%.

**CALL US IF YOU NEED AN ITEM YOU CAN'T FIND IN THIS CATALOG...  
 WE STOCK MANY ITEMS THAT ARE NOT LISTED!**



**WE ARE YOUR STOCKING DISTRIBUTOR FOR THESE  
FINE COMPANIES AND MANY MORE!**

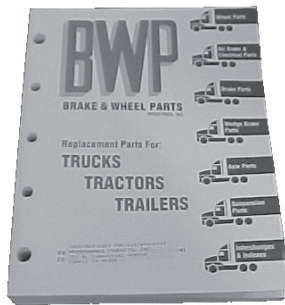

Brake & Wheel Parts Co.

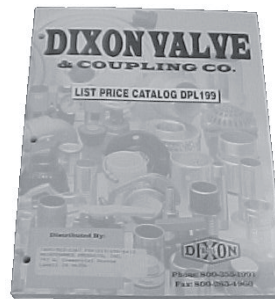

Dixon Valve and Coupling Co.



Auto-Vehicle Parts Co.



E-Z Lok Corp.

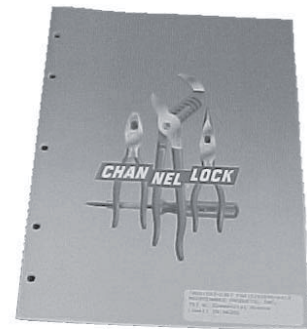

Channellock, Inc.



Champion Cutting Tools Corp.

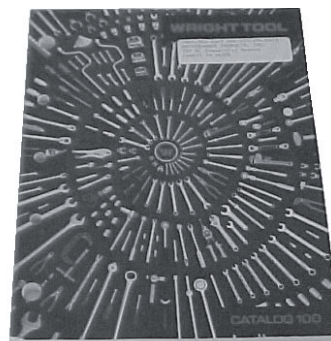

Wright Tool Co.

**CALL FOR FREE CATALOGS!**

# Cotter Pins

Extended prong type. Zinc plated low carbon steel or T304 stainless steel.

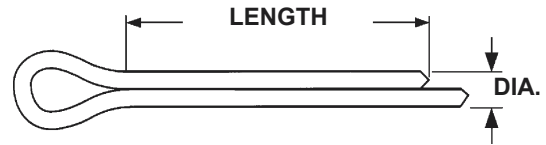

Length	Part Number		Pkg Qty
	Steel	T304 S/S	
<b>1/16" DIAMETER</b>			
1/2	14-007	22-518	100
3/4	14-008	22-519	100
1"	14-009	22-520	100
1-1/4	14-010	-	100
1-1/2	14-011	22-521	100
2"	14-012	22-522	100
<b>3/32" DIAMETER</b>			
1/2	14-014	-	100
3/4	14-015	-	100
1"	14-016	-	100
1-1/4	14-017	22-525	100
1-1/2	14-018	22-526	100
1-3/4	14-019	22-527	100
2"	14-020	22-528	100
2-1/2	14-021	-	100
3"	14-022	-	100
<b>7/64" DIAMETER</b>			
3/4	14-023	-	100
1"	14-024	-	100
1-1/4	14-025	-	100
1-1/2	14-026	-	100
2"	14-028	-	100
<b>1/8" DIAMETER</b>			
1/2	14-029	-	100
3/4	14-030	-	100
1"	14-031	-	100
1-1/4	14-032	22-530	100
1-1/2	14-033	22-531	100
1-3/4	14-034	22-532	100
2"	14-035	22-533	100
2-1/2	14-036	22-534	50
3"	14-037	-	50
<b>5/32" DIAMETER</b>			
3/4	14-039	-	100
1"	14-040	22-535	100
1-1/4	14-041	-	100
1-1/2	14-042	22-536	50
1-3/4	14-043	-	50
2"	14-044	22-538	50
2-1/4	14-045	-	50
2-1/2	14-046	-	25
3"	14-047	22-539	25
<b>3/16" DIAMETER</b>			
3/4	14-048	-	100
1"	14-049	22-540	100
1-1/4	14-050	-	100
1-1/2	14-051	22-541	50
1-3/4	14-052	-	50
2"	14-053	22-542	50
2-1/4	14-054	-	50
2-1/2	14-055	-	25
3"	14-056	22-544	25
3-1/2	14-057	-	25
4"	14-058	-	25

Length	Part Number		Pkg Qty
	Steel	T304 S/S	
<b>1/4" DIAMETER</b>			
1"	14-063	-	50
1-1/4	14-064	-	50
1-1/2	14-065	-	50
1-3/4	14-066	-	50
2"	14-067	-	50
2-1/2	14-068	-	25
3"	14-069	-	25
3-1/2	14-070	-	25
4"	14-071	-	25
<b>5/16" DIAMETER</b>			
1-1/4	14-076	-	50
1-1/2	14-077	-	50
2"	14-078	-	50
2-1/2	14-079	-	25
3"	14-080	-	25
3-1/2	14-081	-	25
4"	14-082	-	25
5"	14-084	-	25
<b>3/8" DIAMETER</b>			
1-1/2	14-086	-	25
2"	14-087	-	25
2-1/2	14-088	-	25
3"	14-089	-	25
3-1/2	14-090	-	25
4"	14-091	-	25
5"	14-092	-	25
6"	14-093	-	25



**COTTER PIN ASSORTMENT**  
24 SIZES, 1/16"-1/4" DIA. IN A LARGE STEEL DRAWER.  
PART NO. 16-3024



**COTTER PIN MAINTENANCE KIT**  
6 SIZES, 1/16"-3/16" IN A CLEAR POLY-STYRENE BOX.  
PART NO. 515MK

# Hairpin Cotters

(Hitch Pin Clips)

Reusable spring-type cotters designed to be strong and secure. Made from hardened 1050 spring wire. Zinc finish.



7-2101



7-2103

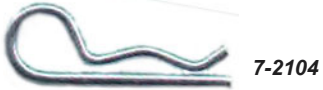

7-2104

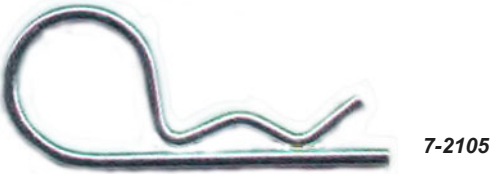

7-2105

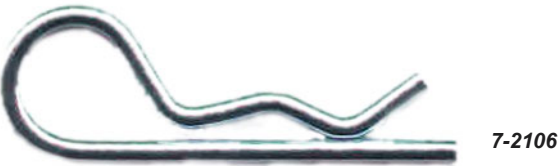

7-2106

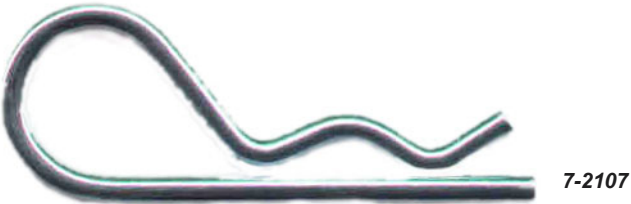

7-2107

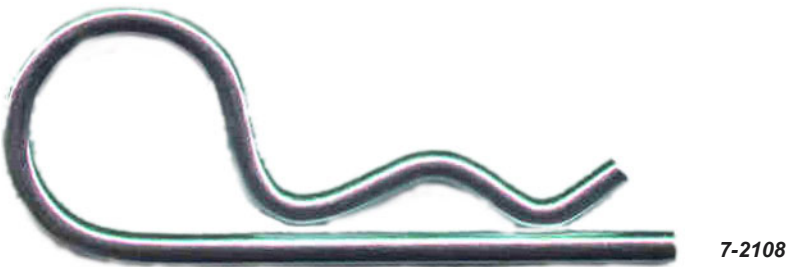

7-2108

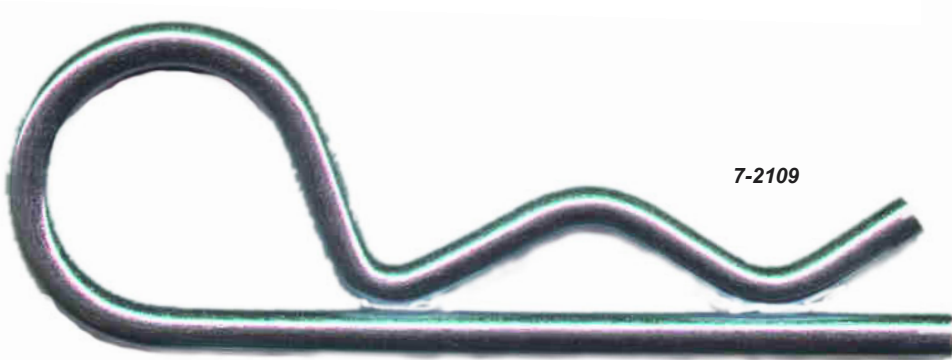

7-2109



7-2110

Part Number	Shaft Size	Wire Diam. x Length	Pkg Qty
7-2101	1/8	.047 X 0.594	100
7-2103	3/16-1/4	.054 X 0.969	100
7-2104	5/16-3/8	.072 X 1.188	100
7-2105	3/8-1/2	.091 X 1.625	50
7-2106	1/2-9/16	.120 X 2.375	50
7-2107	5/8-3/4	.148 X 2.750	25
7-2108	7/8-1	.177 X 3.500	25
7-2109	1-1/8-1-1/2	.243 X 5.000	10
7-2110	-	.306 X 4.000	10

• Available in T302 stainless.



**HAIRPIN COTTER KIT**  
6 SIZES, 1/4 - 1" SHAFT DIA.  
PART NO. 514MK

Illustrations actual size



# Bow-Tie™ Locking Cotter



Works like a hairpin cotter, but it locks! Secure vibration proof design increases safety and reduces liability. Easy on, easy off. No tools required. Made from steel spring wire. Zinc finish.

Part Number	Shaft Size	Wire Diam. x Length	Pkg Qty
7-2126	1/4" - 5/16"	.072" x 1.375"	100
7-2127	5/16" - 3/8"	.091" x 1.875"	50
7-2128	7/16" - 1/2"	.120" x 2.750"	25

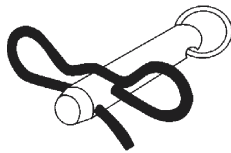

To install, push or pull into hole.

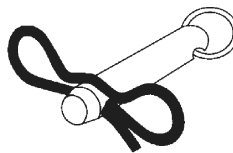

Snap into zero-tension lock position.

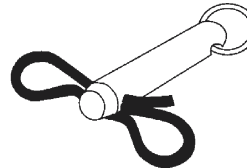

Even if the pin is flipped over the end...it stays locked!

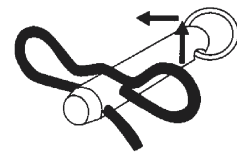

To release, pull locking loop up and over.

*Note: Locking mechanism works best when fit is loose.*

## Safety Pins

Positive locking pin with coil tension made of spring wire. Zinc finish. Pkg Qty: 10 each

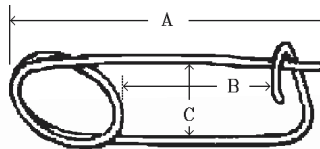

Part Number	O.A. Length (A)	Inside (B)	Width (C)	Wire Dia.
7-2120	2-3/4"	1-11/16"	5/8"	.091"
7-2121	4-3/8"	2-13/16"	13/16"	.120"
7-2122	5-3/4"	3-3/4"	1-1/8"	.148"

7-2120



7-2121



7-2122



*Illustrations actual size*

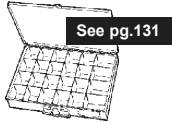

See pg.131

# Spring Pins

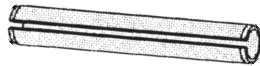

Also called roll pins or expansions pins, these oversized pins expand to grip tightly. Diameter shown is hole size, free pin diameter slightly larger. AISI 1075-1095 high carbonsteel. Chamfered ends. Zinc finish.

Length	Part Number	Pkg Qty	Length	Part Number	Pkg Qty
<b>1/16" DIAMETER</b>			<b>7/32" DIAMETER</b>		
3/16	20-243	50	3/4	20-290	50
1/4	20-244	50	1"	20-291	50
3/8	20-246	50	1-1/4	20-292	50
1/2	20-247	50	1-1/2	20-294	50
5/8	20-248	50	1-3/4	20-295	50
3/4	20-249	50	2"	20-296	50
<b>5/64" DIAMETER</b>			<b>1/4" DIAMETER</b>		
1/4	20-251	50	5/8	20-298	50
3/8	20-252	50	3/4	20-299	50
1/2	20-253	50	1"	20-300	50
3/4	20-255	50	1-1/4	20-301	50
<b>3/32" DIAMETER</b>			<b>5/16" DIAMETER</b>		
1/4	20-260	50	1"	20-309	50
3/8	20-261	50	1-1/4	20-310	50
1/2	20-262	50	1-1/2	20-311	50
5/8	20-263	50	1-3/4	20-312	50
3/4	20-264	50	2"	20-313	50
7/8	20-716	50	2-1/4	20-314	50
1"	20-265	50	2-1/2	20-315	50
1-1/4	20-266	50	3"	20-316	50
1-1/2	20-717	50	3-1/2	20-726	25
<b>1/8" DIAMETER</b>			<b>3/8" DIAMETER</b>		
3/8	20-267	50	1"	20-318	50
1/2	20-268	50	1-1/4	20-319	50
5/8	20-269	50	1-1/2	20-320	50
3/4	20-270	50	1-3/4	20-321	50
7/8	20-718	50	2"	20-322	50
1"	20-271	50	2-1/2	20-323	25
1-1/4	20-272	50	3	20-324	25
1-1/2	20-273	50	3-1/2	20-325	25
2"	20-274	50	<b>7/16" DIAMETER</b>		
<b>5/32" DIAMETER</b>			<b>1/2" DIAMETER</b>		
1/2	20-275	50	1-1/4	20-732	25
5/8	20-276	50	1-1/2	20-331	25
3/4	20-277	50	1-3/4	20-733	25
1"	20-278	50	2"	20-332	25
1-1/4	20-279	50	2-1/2	20-333	25
1-1/2	20-280	50	3"	20-334	25
2"	20-719	50	<b>3/16" DIAMETER</b>		
<b>3/16" DIAMETER</b>			<b>1/2" DIAMETER</b>		
1/2	20-281	50	1-1/4	20-732	25
5/8	20-282	50	1-1/2	20-331	25
3/4	20-283	50	1-3/4	20-733	25
1"	20-284	50	2"	20-332	25
1-1/4	20-285	50	2-1/2	20-333	25
1-1/2	20-286	50	3"	20-334	25
1-3/4	20-287	50	<b>1/2" DIAMETER</b>		
2"	20-288	50	<b>1/2" DIAMETER</b>		
2-1/2	20-289	50	<b>1/2" DIAMETER</b>		

# Coiled Spring Pins

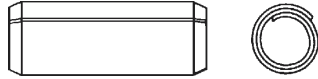

Also known as "spiral pins", these flexible, wound pins fit snugly in "out-of-round" holes and accommodate wider hole tolerances. Use to replace standard spring pins. Absorbs shock and vibration. Excellent for soft and brittle materials. Full 2-¼ coil wrap provides equal stress distribution. Diameter is hole size, free pin diameter slightly larger. Made from 1070-1090 carbon steel. Hardness: Rc 46-53. ANSI-B18.82-197. Chamfered ends. Plain finish.

Size	Part Number	Pkg Qty
1/16 x 1/2	14-125	50
1/16 x 3/4	14-126	50
1/16 x 1	14-127	50
5/64 x 1/2	14-128	50
5/64 x 3/4	14-129	50
5/64 x 1	14-130	50
3/32 x 1/2	14-131	50
3/32 x 3/4	14-132	50
3/32 x 1	14-133	50
3/32 x 1-1/2	14-134	50
1/8 x 1/2	14-135	50
1/8 x 3/4	14-136	50
1/8 x 1	14-137	50
1/8 x 1-1/4	14-138	50
1/8 x 1-1/2	14-139	50
5/32 x 3/4	14-140	50
5/32 x 1	14-141	50
5/32 x 1-1/4	14-142	50
5/32 x 1-1/2	14-143	50
5/32 x 2	14-144	50
3/16 x 1/2	14-145	50
3/16 x 3/4	14-146	50
3/16 x 1	14-147	50
3/16 x 1-1/4	14-148	50
3/16 x 1-1/2	14-149	50
3/16 x 2	14-150	50
3/16 x 2-1/2	14-151	50
7/32 x 3/4	14-152	50
7/32 x 1	14-153	50
7/32 x 1-1/4	14-154	50
7/32 x 1-1/2	14-155	50
7/32 x 2	14-156	50
7/32 x 2-1/2	14-157	50
1/4 x 3/4	14-158	50
1/4 x 1	14-159	50
1/4 x 1-1/4	14-160	50
1/4 x 1-1/2	14-161	50
1/4 x 2	14-162	50
1/4 x 2-1/2	14-163	50
5/16 x 1	14-164	50
5/16 x 1-1/4	14-165	50
5/16 x 1-1/2	14-166	50
5/16 x 2	14-167	50
5/16 x 2-1/2	14-168	50

# Spring Pin Assortments



**SPIROL PIN ASSORTMENT (COILED)**  
24 SIZES, 1/16 - 5/16" DIA. IN A LARGE STEEL DRAWER.  
**PART NO. 16-5224**



**SPRING PIN ASSORTMENT (SPLIT)**  
32 SIZES, 1/16 - 1/2" DIA. IN A LARGE STEEL DRAWER.  
**PART NO. 16-0132**

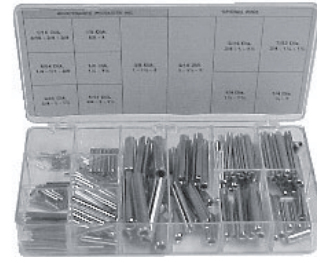

**SPRING PIN MAINTENANCE KIT (SPLIT)**  
32 SIZES, 1/16"-3/8" DIA. IN A POLYSTYRENE BOX.  
**PART NO. 513MK**

# Variety Pin Assortment

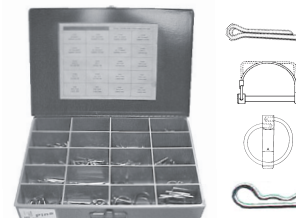

**VARIETY PIN ASSORTMENT**  
20 SIZES, COTTER PINS, HAIRPIN COTTERS,  
WIRE LOCK PINS AND LYNCH PINS IN A LARGE  
STEEL DRAWER. **PART NO. 16-0320**

# Dowel Pins

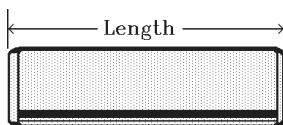

Used for tool and die work, bearings, gauges and precision parts.  
Heat treated alloy steel. Surface hardness: Rc 60. Core hardness: Rc 50-58. Shear PSI: 150,000.  
Dowel Pins are ground to .0002" over sizes listed. Plain finish.

Length	Part Number	Pkg Qty
<b>1/8" DIAMETER</b>		
1/2	20-448	100
5/8	20-757	100
3/4	20-449	100
1"	20-450	100
<b>3/16" DIAMETER</b>		
1/2	20-453	50
5/8	20-454	50
3/4	20-455	50
1"	20-456	50
1-1/4	20-457	50
1-1/2	20-458	50
2"	20-459	50
<b>1/4" DIAMETER</b>		
1/2	20-460	50
5/8	20-763	50
3/4	20-461	50
1"	20-462	50
1-1/4	20-463	50
1-1/2	20-464	50
1-3/4	20-465	50
2"	20-466	50
2-1/2	20-468	50
<b>5/16" DIAMETER</b>		
3/4	20-470	50
7/8	20-471	50
1"	20-472	50
1-1/4	20-473	50
1-1/2	20-474	50
1-3/4	20-475	50
2"	20-476	50
2-1/4	20-766	50
2-1/2	20-477	50
3"	20-767	50

Length	Part Number	Pkg Qty
<b>3/8" DIAMETER</b>		
1/2	20-768	50
5/8	20-769	50
3/4	20-478	50
7/8	20-770	50
1"	20-479	50
1-1/4	20-480	50
1-1/2	20-481	50
2"	20-483	50
3"	20-485	50
<b>7/16" DIAMETER</b>		
1-1/2	20-488	25
2"	20-490	25
<b>1/2" DIAMETER</b>		
3/4	20-774	25
1"	20-491	25
1-1/4	20-492	25
1-1/2	20-493	25
2"	20-495	25
2-1/2	20-496	25
3"	20-497	10
3-1/2	20-776	10

## CUSTOM ASSORTMENTS



**MADE TO YOUR SPECIFICATIONS!**

**Red Hot Deals!**

Check out our current specials and new items on our website at <http://www.mpi-online.com>

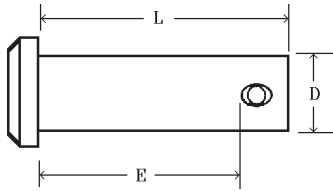

# Clevis Pins

Material: 3/16-3/8 dia.; 1008/1010 carbon steel, 7/16-3/4 dia.;  
 AISI 1018 carbon steel. Cold headed. Chamfered holes. Plain finish.

See table on next page for clevis pin hole dimensions.

Part Number	Size (D x L)	Effective Length (E)	Pkg Qty
20-847	3/16 x 1/2	.359	25
20-848	3/16 x 5/8	.484	25
20-335	3/16 x 3/4	.609	25
20-336	3/16 x 1"	.859	25
20-849	3/16 x 1-1/4	1.109	25
20-850	3/16 x 1-1/2	1.359	25
20-851	3/16 x 2"	1.859	25
20-852	3/16 x 2-1/2	2.359	25
20-853	3/16 x 3"	2.859	25
20-854	1/4 x 1/2	.359	25
20-855	1/4 x 5/8	.484	25
20-856	1/4 x 3/4	.609	25
20-337	1/4 x 1"	.859	25
20-338	1/4 x 1-1/8	.984	25
20-339	1/4 x 1-1/4	1.109	25
20-340	1/4 x 1-1/2	1.359	25
20-341	1/4 x 1-3/4	1.609	25
20-342	1/4 x 2"	1.859	25
20-343	1/4 x 2-1/4	2.109	25
20-344	1/4 x 2-1/2	2.359	25
20-857	1/4 x 3"	2.859	25
20-858	1/4 x 3-1/2	3.359	10
20-345	1/4 x 4"	3.859	10
20-859	1/4 x 5"	4.859	10
20-860	5/16 x 1"	.813	25
20-861	5/16 x 1-1/8	.938	25
20-346	5/16 x 1-1/4	1.063	25
20-347	5/16 x 1-3/8	1.188	25
20-348	5/16 x 1-1/2	1.313	25
20-349	5/16 x 1-3/4	1.563	25
20-350	5/16 x 2"	1.813	25
20-862	5/16 x 2-1/2	2.313	25
20-351	5/16 x 3"	2.813	25
20-863	5/16 x 3-1/2	3.313	10
20-352	5/16 x 4"	3.765	10
20-864	5/16 x 6"	5.765	10
20-353	3/8 x 1"	.766	25
20-354	3/8 x 1-1/8	.891	25
20-356	3/8 x 1-1/4	1.016	25
20-357	3/8 x 1-1/2	1.266	25
20-358	3/8 x 1-3/4	1.516	25
20-359	3/8 x 2"	1.766	25
20-360	3/8 x 2-1/4	2.016	25
20-361	3/8 x 2-1/2	2.266	25
20-362	3/8 x 3"	2.766	25
20-865	3/8 x 3-1/2	3.266	10
20-363	3/8 x 4"	3.766	10
20-866	3/8 x 6-1/8	5.890	10
20-364	7/16 x 1-1/4	1.016	25
20-365	7/16 x 1-1/2	1.266	25
20-867	7/16 x 1-3/4	1.516	25
20-868	7/16 x 2"	1.766	25
20-869	7/16 x 2-1/2	2.266	25

Part Number	Size (D x L)	Effective Length (E)	Pkg Qty
20-870	7/16 x 3"	2.766	25
20-871	7/16 x 3-1/2	3.266	10
20-872	7/16 x 4"	3.766	10
20-366	1/2 x 1-1/2	1.266	25
20-367	1/2 x 1-3/4	1.516	25
20-368	1/2 x 2"	1.766	25
20-369	1/2 x 2-1/4	2.016	25
20-370	1/2 x 2-1/2	2.266	25
20-371	1/2 x 2-3/4	2.516	25
20-372	1/2 x 3"	2.766	25
20-873	1/2 x 3-1/2	3.266	10
20-373	1/2 x 4"	3.766	10
20-374	1/2 x 5"	4.766	10
20-375	1/2 x 6"	5.766	10
20-376	9/16 x 2"	1.766	10
20-874	9/16 x 2-1/2	2.266	10
20-875	9/16 x 3"	2.766	10
20-876	9/16 x 4"	3.766	10
20-377	5/8 x 1-1/2	1.266	10
20-378	5/8 x 1-3/4	1.516	10
20-379	5/8 x 2"	1.766	10
20-380	5/8 x 2-1/4	2.016	10
20-381	5/8 x 2-1/2	2.266	10
20-877	5/8 x 3"	2.766	10
20-878	5/8 x 3-1/2	3.266	10
20-382	5/8 x 4"	3.766	10
20-879	5/8 x 4-3/4	4.515	10
20-880	5/8 x 5-1/2	5.266	10
20-383	5/8 x 6"	5.766	10
20-881	5/8 x 6-1/2	6.266	10
20-384	3/4 x 2-1/2	2.266	10
20-385	3/4 x 2-3/4	2.516	10
20-882	3/4 x 3"	2.766	10
20-883	3/4 x 3-1/2	3.266	10
20-884	3/4 x 4"	3.766	10
20-885	3/4 x 4-1/2	4.266	10
20-886	3/4 x 5"	4.766	10
20-887	3/4 x 6-1/2	6.266	10

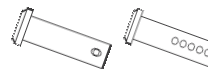

**CLEVIS PIN ASSORTMENT**  
 (STANDARD & UNIVERSAL)  
 24 SIZES, 3/16"-1/2"  
 DIAMETER IN A LARGE  
 STEEL DRAWER.  
**PART NO. 16-3224**

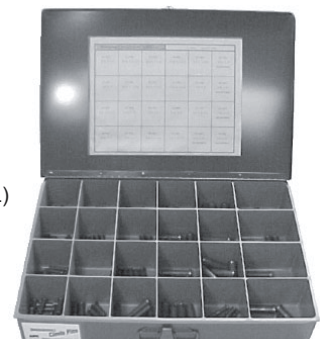

# Universal Clevis Pins

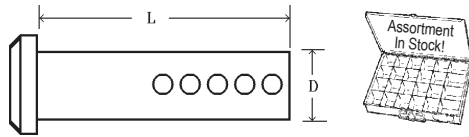

Adjustable pins with multiple holes that are 1/4" on center. Low carbon steel. Plain Finish

Size (D x L)	Part Number	Pkg Qty
3/16 X 1-1/2	20-824	10
3/16 X 2"	20-388	10
3/16 X 2-1/2	20-825	10
3/16 X 3"	20-826	10
1/4 X 2"	20-389	10
1/4 X 2-1/2	20-827	10
1/4 X 3"	20-828	10
1/4 X 3-1/2	20-829	10
1/4 X 4"	20-830	10
5/16 X 2"	20-390	10
5/16 X 2-1/2	20-831	10
5/16 X 3"	20-832	10
5/16 X 3-1/2	20-833	10
5/16 X 4"	20-834	10
3/8 X 2"	20-391	10
3/8 X 2-1/2	20-392	10
3/8 X 3"	20-835	10
3/8 X 3-1/2	20-836	10
3/8 X 4"	20-837	10
7/16 X 2"	20-393	10
7/16 X 2-1/2	20-394	10
7/16 X 3"	20-395	10
7/16 X 3-1/2	20-838	10
7/16 X 4"	20-839	10
1/2 X 2"	20-396	10
1/2 X 2-1/2	20-397	10
1/2 X 3"	20-398	10
1/2 X 3-1/2	20-840	10
1/2 X 4"	20-841	10
9/16 X 2"	20-842	10
9/16 X 3"	20-843	10
9/16 X 4"	20-844	10
5/8 X 2"	20-845	10
5/8 X 3"	20-399	10
5/8 X 4"	20-846	10

# Bent Pull Pins

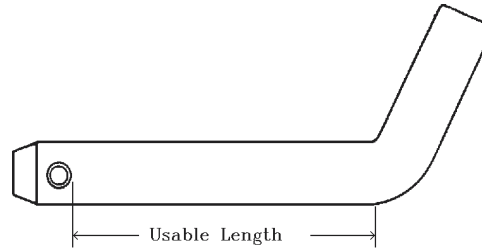

WITH HAIRPIN COTTER

A low cost pin with handle and pin bent in a one piece configuration. Commonly found on trailer hitch receivers. Machined from AISI 1018 - 12L14 carbon steel\*. Zinc finish.

Part Number	Diameter	Usable Length	Pkg Qty
7-2123	1/2"	3"	5
7-2124	5/8"	3"	5

*\*Also available: 1045 or 1144 high strength alloy steel, subject to minimum order.*

# Taper Pins



**MOST SIZES IN STOCK!**

For accurate hole alignment on sprocket and gear assemblies. Large end diameter tolerance: +.0013" to -.0007". Uniform taper runs full length of the pin. Standard taper is 1/4" per foot. Milled from C12L14 low carbon steel. Plain machined finish. Meets MS 24692.

*Tip: Stock long length taper pins. They may be easily cut to size, thus reducing overall taper pin inventory.*

**PLEASE CALL OUR OFFICE FOR SIZES AND AVAILABILITY.**

## Measuring Taper Pins

CLEVIS PIN HOLE DIAMETERS				
Pin diameter	3/16	1/4	5/16	3/8-3/4
Hole diameter	3/32	3/32	1/8	5/32

TAPER PIN TRADE SIZE											
	#0	#1	#2	#3	#4	#5	#6	#7	#8	#9	#10
LARGE END DIAMETER	.156	.172	.193	.219	.250	.289	.341	.409	.492	.591	.706
CLOSEST FRACTION	5/32	11/64	3/16	7/32	1/4	19/64	11/32	13/32	1/2	19/32	23/32

# Internal Retaining Rings

Fits in groove in the housing bore.  
Made from spring steel. Phosphate & oil finish.

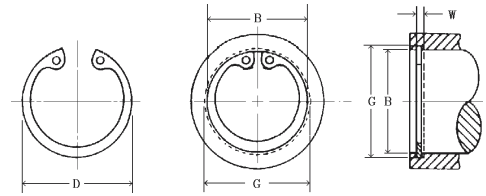

Part Number	Bore Dia. (B)	Groove Dia. (G)	Groove Width (W)	Free O.D. (D)	Mfr Number	Pkg Qty
20-556	1/4	.268	.018	.280	N1300-25	50
20-557	5/16	.330	.018	.346	N1300-31	50
20-558	3/8	.397	.029	.415	N1300-37	50
20-559	7/16	.461	.029	.482	N1300-43	50
20-560	1/2	.530	.039	.548	N1300-50	50
20-561	9/16	.596	.039	.620	N1300-56	50
20-562	5/8	.665	.039	.694	N1300-62	50
20-563	11/16	.732	.039	.763	N1300-68	50
20-564	3/4	.796	.039	.831	N1300-75	50
20-565	13/16	.862	.046	.901	N1300-81	50
20-566	7/8	.931	.046	.971	N1300-87	50
20-567	15/16	1.000	.046	1.041	N1300-93	50
20-568	1"	1.066	.046	1.111	N1300-100	50
20-569	1.023	1.091	.046	1.136	N1300-102	25
20-570	1-1/16	1.130	.056	1.180	N1300-106	25
20-571	1-1/8	1.197	.056	1.249	N1300-112	25
20-573	1-1/4	1.330	.056	1.388	N1300-125	25
20-574	1-5/16	1.396	.056	1.456	N1300-131	25
20-575	1-3/8	1.461	.056	1.526	N1300-137	25
20-576	1-7/16	1.528	.056	1.596	N1300-143	25
20-577	1-1/2	1.594	.056	1.660	N1300-150	25
20-578	1-5/8	1.725	.068	1.804	N1300-162	25
20-579	1-3/4	1.858	.068	1.942	N1300-175	25
20-580	1-7/8	1.989	.068	2.072	N1300-187	10
20-581	2"	2.122	.068	2.210	N1300-200	10
20-582	2-1/8	2.251	.086	2.350	N1300-212	10
20-583	2-1/4	2.382	.086	2.490	N1300-255	10
20-584	2-5/16	2.450	.086	2.560	N1300-231	10
20-585	2-3/8	2.517	.086	2.630	N1300-237	10
20-586	2-1/2	2.648	.086	2.775	N1300-250	10

Also available in metric and larger sizes thru 10" diameter. Waldes ref. no. - N5000 (-size). IRR ref. no. - 3000 (-size).



**EXTERNAL AND INTERNAL  
RETAINING RING ASSORTMENT**  
24 SIZES, 1/4"-1-1/2" IN A LARGE STEEL DRAWER.  
**PART NO. 16-3324**



**INTERNAL RETAINING RING MAINTENANCE KIT**  
12 SIZES, 3/8"-1-1/2" DIA. IN A POLYSTYRENE BOX.  
**PART NO. 550MK**



**EXTERNAL, INTERNAL AND E-TYPE  
RETAINING RING ASSORTMENT**  
24 SIZES IN A LARGE STEEL DRAWER.  
**PART NO. 16-3424**

(See other Maintenance Kits on pages 136 & 137)

# External Retaining Rings

External rings require a groove on shaft.  
Made from spring steel. Phosphate & oil finish.

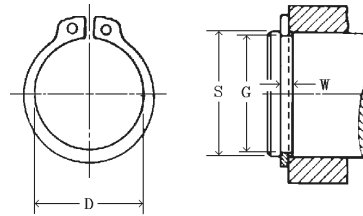

Part Number	Shaft Dia. (S)	Groove Dia. (G)	Groove Width (W)	Free I.D. (D)	Mfr Number	Pkg Qty
20-510	1/8	.117	.012	.112	1400-12	50
20-511	5/32	.146	.012	.142	1400-15	50
20-512	3/16	.175	.018	.168	1400-18	50
20-513	7/32	.205	.018	.196	1400-21	50
20-514	1/4	.230	.029	.225	1400-25	50
20-515	9/32	.261	.029	.256	1400-28	50
20-516	5/16	.290	.029	.281	1400-31	50
20-517	11/32	.321	.029	.309	1400-34	50
20-518	3/8	.352	.029	.338	1400-37	50
20-519	13/32	.382	.039	.366	1400-40	50
20-520	7/16	.412	.029	.395	1400-43	50
20-521	15/32	.443	.029	.428	1400-46	50
20-522	1/2	.468	.039	.461	1400-50	50
20-524	9/16	.530	.039	.521	1400-56	50
20-525	19/32	.559	.039	.550	1400-59	50
20-526	5/8	.588	.039	.579	1400-62	50
20-527	11/16	.646	.046	.635	1400-68	50
20-528	3/4	.704	.046	.693	1400-75	50
20-529	13/16	.762	.046	.751	1400-81	50
20-530	7/8	.821	.046	.810	1400-87	50
20-531	15/16	.882	.046	.867	1400-93	50
20-532	1"	.940	.046	.925	1400-100	50
20-533	1.023	.961	.046	.946	1400-102	25
20-534	1-1/16	.998	.056	.982	1400-106	25
20-535	1-1/8	1.059	.056	1.041	1400-112	25
20-536	1-3/16	1.118	.056	1.098	1400-118	25
20-538	1-1/4	1.176	.056	1.156	1400-125	25
20-539	1-5/16	1.232	.056	1.214	1400-131	25
20-540	1-3/8	1.291	.056	1.272	1400-137	25
20-541	1-7/16	1.350	.056	1.333	1400-143	25
20-542	1-1/2	1.406	.056	1.387	1400-150	25
20-543	1-9/16	1.468	.068	1.446	1400-156	25
20-544	1-5/8	1.529	.068	1.503	1400-162	25
20-545	1-3/4	1.650	.068	1.618	1400-175	25
20-547	1-7/8	1.769	.068	1.735	1400-187	10
20-548	2"	1.886	.068	1.850	1400-200	10
20-549	2-1/8	2.003	.086	1.964	1400-212	10
20-550	2-1/4	2.120	.086	2.081	1400-225	10
20-551	2-3/8	2.239	.086	2.197	1400-237	10
20-552	2-1/2	2.360	.086	2.313	1400-250	10

Also available in metric and larger sizes. Waldes ref. no. - 5100 (-size). IRR ref. no. - 3100 (-size)



**EXTERNAL RETAINING RING MAINTENANCE KIT**  
12 SIZES, 1/4"-1-1/4" DIA. IN A POLYSTYRENE BOX.  
**PART NO. 516MK**

**SERVICE IS OUR PRIORITY!**  
**OUR COMMITMENT IS TO**  
**MEET YOUR NEEDS!**



# "E" Type Retaining Rings

Made from spring steel. Phosphate & oil finish.

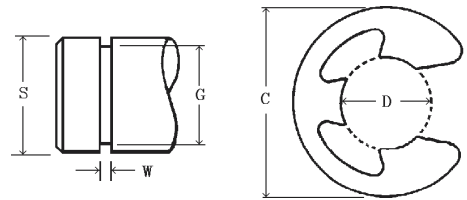

Part Number	Shaft Dia. (S)	Groove Dia. (G)	Groove Width (W)	Free I.D. (D)	Free O.D. (C)	Mfr Number	Pkg Qty
20-592	1/16	.052	.012	.051	.165	1500-6	100
20-593	3/32	.074	.018	.073	.187	1500-9	100
20-594	1/8	.095	.018	.094	.230	1500-12	100
20-611	9/64	.105	.029	.108	.270	1500-14	100
20-595	5/32	.116	.029	.114	.282	1500-15	100
20-596	11/64	.127	.029	.125	.312	1500-X17	100
20-597	3/16	.125	.029	.122	.375	1500-X18	100
20-598	7/32	.188	.029	.185	.437	1500-X21	100
20-599	1/4	.210	.029	.207	.527	1500-25	100
20-600	5/16	.250	.029	.243	.500	1500-X31	100
20-601	3/8	.303	.039	.300	.660	1500-37	100
20-602	7/16	.343	.039	.337	.687	1500-43	100
20-603	1/2	.396	.046	.392	.800	1500-50	100
20-604	9/16	.437	.046	.430	.870	1540-56	50
20-605	5/8	.485	.046	.480	.940	1500-62	50
20-606	3/4	.625	.056	.616	1.000	1500-X74	50
20-607	7/8	.675	.056	.668	1.300	1500-87	50
20-608	1"	.835	.056	.822	1.500	1500-X98	50
20-609	1-3/16	1.079	.068	1.066	1.626	1550-X118	25
20-610	1-3/8	1.230	.068	1.213	1.875	1500-X137	25

Also available in metric and larger sizes. Waldes ref. no. - 5133 (-size). IRR ref. no. - 1000 (-size).

**SAVE WHEN YOU  
BUY IN QUANTITY!**



**E-TYPE RETAINING RING MAINTENANCE KIT**  
12 SIZES, 1/16"-3/4" DIA. IN A POLYSTYRENE BOX. PART NO. 517MK

## Retaining Ring Pliers



### CONVERTIBLE (THUMB-SCREW TYPE)

Comfortable vinyl cushion grips. Black oxide finish. Fully hardened steel. Straight tips. Made in U.S.A.

Part No.	O.A. Length	Range Internal	Range External	Tip Dia.
10-616	5 3/4"	3/8" - 1.023"	1/4" - 7/8"	.038"
10-617	8"	1 1/16" - 1 3/4"	15/16" - 1 7/16"	.070"



### PUSH-BUTTON CONVERTIBLE

Fast conversion without disassembly. Vinyl cushion grips. Chrome finish. Tips supplied in 3 popular diameters. Tip sets are replaceable. Made in U.S.A. (Wright Tool).

Part No.	Internal	External	Replacement Tip Set
WT-9H1221S	1/4" - 1"	1/8" - 1"	WT-9H1221RK
WT-9H1234	3/8" - 2"	1/4" - 2"	WT-9H1234RK

# Woodruff Keys

(Half-Moon Keys)

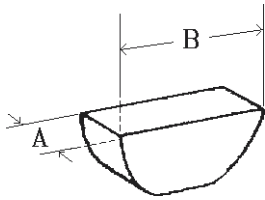

Machined 1035 low carbon steel. Rounded corners for easy insertion. Plain finish.

Part Number	Thickness (A)	Length (B)	Trade No.	Pkg Qty
20-089	3/32	1/2	2	50
20-090	3/32	5/8	4	50
20-091	1/8	1/2	3	50
20-092	1/8	5/8	5	50
20-093	1/8	3/4	7	50
20-094	5/32	5/8	6	50
20-095	5/32	3/4	8	50
20-096	5/32	7/8	10	50
20-097	3/16	5/8	61	50
20-098	3/16	3/4	9	50
20-099	3/16	7/8	11	50
20-100	3/16	1"	13	50
20-101	3/16	1-1/8	16	50
20-102	3/16	1-1/4	19	50
20-103	7/32	7/8	12	50
20-104	7/32	1"	14	50
20-105	7/32	1-1/8	17	50
20-106	7/32	1-1/4	20	50
20-107	1/4	3/4	91	50
20-108	1/4	7/8	A	50
20-109	1/4	1"	15	50
20-110	1/4	1-1/8	18	25
20-111	1/4	1-1/4	21	25
20-112	1/4	1-3/8	22	25
20-113	1/4	1-1/2	24	25
20-114	5/16	1"	B	25
20-115	5/16	1-1/8	C	25
20-116	5/16	1-1/4	D	25
20-117	5/16	1-3/8	23	25
20-118	5/16	1-1/2	25	25
20-119	3/8	1"	152	25
20-120	3/8	1-1/4	E	25
20-121	3/8	1-3/8	F	25
20-122	3/8	1-1/2	G	25

*"Our patience will achieve more than our force."*

- Edmund Burke



**WOODRUFF KEY ASSORTMENT**  
24 SIZES, 3/32"-3/8" THICK IN A LARGE STEEL DRAWER.  
**PART NO. 16-3624**



**WOODRUFF KEY MAINTENANCE KIT**  
18 SIZES, 3/32" - 5/16" THICK KEYS IN A CLEAR POLYSTYRENE BOX. **PART NO. 518MK**

# Shaft Collars

(Drill Stops or Set Collars)

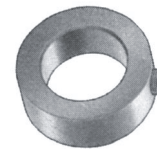

Includes cup point socket set screws for a positive lock. Machined from 1035 low carbon steel. Stamped with shaft size. Zinc finish.

Part Number	Shaft Size	Outside Dia.	Width	Pkg Qty
20-144	3/8	3/4	3/8	10
20-146	1/2	1"	7/16	10
20-148	5/8	1-1/8	1/2	5
20-150	3/4	1-1/4	9/16	5
20-152	7/8	1-1/2	9/16	5
20-153	15/16	1-5/8	9/16	5
20-154	1"	1-5/8	5/8	5
20-156	1-1/8	1-3/4	5/8	1
20-157	1-3/16	2"	11/16	1
20-158	1-1/4	2"	11/16	1
20-160	1-3/8	2-1/8	3/4	1
20-161	1-7/16	2-1/4	3/4	1
20-162	1-1/2	2-1/4	3/4	1

Other styles and sizes available on special request.



# Key Stock

Make your own machinery keys from standard length stock. Available in cold drawn C1018 low carbon steel or Type 304 stainless steel. *Note: steel square stock is plain finish, steel rectangular stock is zinc plated.*

Undersize tolerances  
 steel unplated: +.000" to -.003";  
 steel plated: +.001" to -.002";  
 stainless: +.000" to -.002"

SIZE	LENGTH	STYLE	C1018 STEEL PART NO.	T304 STAINLESS PART NO.	PKG. QTY.
1/8"	12"	SQUARE	20-123	22-244	6
3/16"	12"	SQUARE	20-124	22-245	6
1/4"	12"	SQUARE	20-125	22-246	6
5/16"	12"	SQUARE	20-126	22-247	6
3/8"	12"	SQUARE	20-127	22-248	6
7/16"	12"	SQUARE	20-128	—	4
1/2"	12"	SQUARE	20-129	22-249	4
9/16"	12"	SQUARE	20-130	—	2
5/8"	12"	SQUARE	20-131	22-250	2
3/4"	12"	SQUARE	20-132	22-251	2
7/8"	12"	SQUARE	20-133	22-252	1
1"	12"	SQUARE	20-134	22-253	1
3/16 x 1/4	12"	RECTANGULAR	20-135	—	6
1/4 x 5/16	12"	RECTANGULAR	20-136	—	6
5/16 x 3/8	12"	RECTANGULAR	20-137	—	6
3/8 x 1/2	12"	RECTANGULAR	20-138	—	6

## Key Stock Assortments



**KEY STOCK DRAWER ASSORTMENT**  
 1018 CARBON STEEL KEY STOCK, 6 SIZES, IN 6 COMPT.  
 STEEL DRAWER. **PART NO. 16-5106**

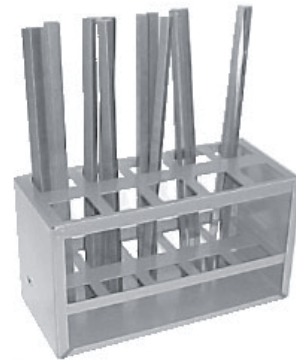

**STEEL KEY STOCK ASSORTMENT**  
 6 SIZES, 1/8" - 1/2" SQUARE KEY STOCK IN 20-140 RACK.  
**PART NO. 20-139**

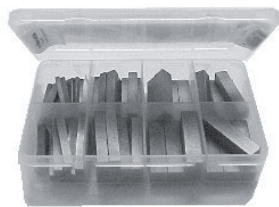

**MACHINERY KEY MAINTENANCE KIT**  
 1018 CARBON STEEL KEYS, 1/8" - 3/8", 6 SIZES, ALL 1 1/2"  
 LONG IN A POLYPROPYLENE BOX. **PART NO. 545MK**

**T304 STAINLESS KEY STOCK ASSORTMENT**  
 5 SIZES, 1/8" - 1/2" SQUARE KEY STOCK IN 20-140 RACK.  
**PART NO. 22-751**  
 (Note: 7/16" stainless steel keystock is not included.)

**KEY STOCK RACK ONLY**  
 TEN 1 1/2" SQUARE COMPARTMENTS STORES KEY STOCK UP TO 12" LONG. SIZE: 10 1/2"W X 6"H X 5"D.  
 Key Stock not included. **PART NO. 20-140**

# "O" Rings

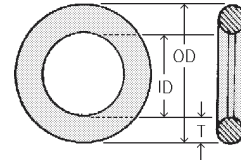

Buna "N" (nitrile) Compound - the most commonly used. For use with mild acids and alkalis, anhydrous ammonia, water, solvents, gasoline and non-aromatic fuels, transmission and hydraulic fluids, motor oil, silicone. High abrasion and tear resistance. *FDA approved. SAE 120R class 1, Hardness is 70 ±5 Shore A durometer. Temperature range: -40°F to +300°F (Do not expose to ketones, brake fluids, strong acids, or ozone. Not for outdoor use.) SAE standard sizes AS-568. Color: Black.*

## 1/16" Thick (.070")

Part Number	Size ID x OD	Trade No.	Pkg Qty
20-612	1/8 x 1/4	-006	50
20-613	5/32 x 9/32	-007	50
20-614	3/16 x 5/16	-008	50
20-615	7/32 x 11/32	-009	50
20-616	1/4 x 3/8	-010	50
20-617	5/16 x 7/16	-011	50
20-618	3/8 x 1/2	-012	50
20-619	7/16 x 9/16	-013	50
20-620	1/2 x 5/8	-014	50
20-621	9/16 x 11/16	-015	50
20-622	5/8 x 3/4	-016	50
20-623	11/16 x 13/16	-017	50
20-683	3/4 x 7/8	-018	50
20-684	13/16 x 15/16	-019	50
20-624	7/8 x 1"	-020	50
20-685	15/16 x 1-1/16	-021	50
20-625	1" x 1-1/8	-022	25
20-626	1-1/16 x 1-3/16	-023	25
20-627	1-1/8 x 1-1/4	-024	25
20-686	1-3/16 x 1-5/16	-025	25
20-628	1-1/4 x 1-3/8	-026	25
20-687	1-5/16 x 1-7/16	-027	25
20-629	1-3/8 x 1-1/2	-028	25
20-630	1-1/2 x 1-5/8	-029	25
20-688	1-5/8 x 1-3/4	-030	25
20-689	1-3/4 x 1-7/8	-031	25
20-690	1-7/8 x 2"	-032	25
20-691	2" x 2-1/8	-033	10
20-692	2-1/8 x 2-1/4	-034	10
20-631	2-1/4 x 2-3/8	-035	10
20-969	2-3/8 x 2-1/2	-036	10
20-970	2-1/2 x 2-5/8	-037	10
20-971	2-5/8 x 2-3/4	-038	10
20-972	2-3/4 x 2-7/8	-039	10
20-973	2-7/8 x 3"	-040	10
20-974	3" x 3-1/8	-041	10
20-975	3-1/4 x 3-3/8	-042	10
20-976	3-1/2 x 3-5/8	-043	10
20-977	3-3/4 x 3-7/8	-044	10
20-978	4" x 4-1/8	-045	10

## 3/32" Thick (.103")

Part Number	Size ID x OD	Trade No.	Pkg Qty
20-693	1/8 x 5/16	-104	50
20-694	5/32 x 11/32	-105	50
20-695	3/16 x 3/8	-106	50
20-696	7/32 x 13/32	-107	50
20-697	1/4 x 7/16	-108	50
20-698	5/16 x 1/2	-109	50
20-632	3/8 x 9/16	-110	50
20-633	7/16 x 5/8	-111	50
20-634	1/2 x 11/16	-112	50
20-635	9/16 x 3/4	-113	50
20-636	5/8 x 13/16	-114	50
20-637	11/16 x 7/8	-115	50
20-638	3/4 x 15/16	-116	50
20-699	13/16 x 1"	-117	50
20-639	7/8 x 1-1/16	-118	50
20-700	15/16 x 1-1/8	-119	50
20-701	1" x 1-3/16	-120	25
20-640	1-1/16 x 1-1/4	-121	25
20-702	1-1/8 x 1-5/16	-122	25
20-703	1-3/16 x 1-3/8	-123	25
20-704	1-1/4 x 1-7/16	-124	25
20-641	1-5/16 x 1-1/2	-125	25
20-642	1-3/8 x 1-9/16	-126	25
20-643	1-7/16 x 1-5/8	-127	25
20-705	1-1/2 x 1-11/16	-128	25
20-979	1-9/16 x 1-3/4	-129	25
20-980	1-5/8 x 1-13/16	-130	25
20-981	1-11/16 x 1-7/8	-131	25
20-982	1-3/4 x 1-15/16	-132	25
20-983	1-13/16 x 2"	-133	25
20-984	1-7/8 x 2-1/16	-134	25
20-985	1-15/16 x 2-1/8	-135	25
20-986	2" x 2-3/16	-136	10
20-987	2-1/16 x 2-1/4	-137	10
20-988	2-1/8 x 2-5/16	-138	10
20-989	2-3/16 x 2-3/8	-139	10
20-990	2-1/4 x 2-7/16	-140	10
20-991	2-5/16 x 2-1/2	-141	10
20-992	2-3/8 x 2-9/16	-142	10
20-993	2-7/16 x 2-5/8	-143	10
20-994	2-1/2 x 2-11/16	-144	10
20-995	2-9/16 x 2-3/4	-145	10
20-996	2-5/8 x 2-13/16	-146	10
20-997	2-11/16 x 2-7/8	-147	10
20-998	2-3/4 x 2-15/16	-148	10
20-999	2-13/16 x 3"	-149	10
20-1000	2-7/8 x 3-1/16	-150	10
20-1001	3" x 3-3/16	-151	10
20-1002	3-1/4 x 3-7/16	-152	10
20-1003	3-1/2 x 3-11/16	-153	10
20-1004	3-3/4 x 3-15/16	-154	10
20-1005	4" x 4-3/16	-155	10
20-1006	4-1/4 x 4-7/16	-156	10

*Do what you can,  
with what you are,  
where you are.*

-Theodore Roosevelt

See O-Ring sizing chart on pg. 144

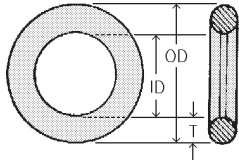

# "O" Rings (cont'd)

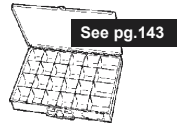

## 1/8 Thick (.139")

Part Number	Size ID x OD	Trade No.	Pkg Qty
20-706	1/2 x 3/4	-206	50
20-707	9/16 x 13/16	-207	50
20-644	5/8 x 7/8	-208	50
20-708	11/16 x 15/16	-209	50
20-645	3/4 x 1"	-210	50
20-646	13/16 x 1-1/16	-211	50
20-647	7/8 x 1-1/8	-212	50
20-648	15/16 x 1-3/16	-213	50
20-649	1" x 1-1/4	-214	25
20-650	1-1/16 x 1-5/16	-215	25
20-651	1-1/8 x 1-3/8	-216	25
20-652	1-3/16 x 1-7/16	-217	25
20-653	1-1/4 x 1-1/2	-218	25
20-654	1-5/16 x 1-9/16	-219	25
20-655	1-3/8 x 1-5/8	-220	25
20-656	1-7/16 x 1-11/16	-221	25
20-657	1-1/2 x 1-3/4	-222	25
20-658	1-5/8 x 1-7/8	-223	25
20-659	1-3/4 x 2"	-224	25
20-660	1-7/8 x 2-1/8	-225	25
20-661	2" x 2-1/4	-226	10
20-662	2-1/8 x 2-3/8	-227	10
20-709	2-1/4 x 2-1/2	-228	10
20-663	2-3/8 x 2-5/8	-229	10
20-664	2-1/2 x 2-3/4	-230	10
20-665	2-5/8 x 2-7/8	-231	10
20-666	2-3/4 x 3"	-232	10
20-667	2-7/8 x 3-1/8	-233	10
20-668	3" x 3-1/4	-234	10
20-710	3-1/8 x 3-3/8	-235	10
20-669	3-1/4 x 3-1/2	-236	10
20-935	3-3/8 x 3-5/8	-237	10
20-936	3-1/2 x 3-3/4	-238	10
20-937	3-5/8 x 3-7/8	-239	10
20-938	3-3/4 x 4"	-240	10
20-939	3-7/8 x 4-1/8	-241	10
20-940	4" x 4-1/4	-242	10
20-941	4-1/8 x 4-3/8	-243	10
20-942	4-1/4 x 4-1/2	-244	10
20-943	4-3/8 x 4-5/8	-245	10
20-944	4-1/2 x 4-3/4	-246	10
20-945	4-5/8 x 4-7/8	-247	10
20-946	4-3/4 x 5"	-248	10
20-947	4-7/8 x 5-1/8	-249	10
20-948	5" x 5-1/4	-250	10
20-949	5-1/8 x 5-3/8	-251	10
20-950	5-1/4 x 5-1/2	-252	10
20-951	5-1/2 x 5-3/4	-254	10
20-952	5-3/4 x 6"	-256	10
20-953	6" x 6-1/4	-258	10
20-954	6-1/2 x 6-3/4	-260	10
20-955	6-3/4 x 7"	-261	10

Also available upon special order: thicknesses up to 1/2", diameters to 100" ID, back-up O-Rings, U-Cups. Other materials available: silicone, nitrile (orange dot) and neoprene material (blue). Subject to minimum order quantity.

## 3/16 Thick (.210")

Part Number	Size ID x OD	Trade No.	Pkg Qty
20-670	1-1/4 x 1-5/8	-322	25
20-711	1-5/16 x 1-11/16	-323	25
20-712	1-3/8 x 1-3/4	-324	25
20-671	1-1/2 x 1-7/8	-325	25
20-672	1-5/8 x 2"	-326	25
20-673	1-3/4 x 2-1/8	-327	25
20-674	1-7/8 x 2-1/4	-328	25
20-675	2" x 2-3/8	-329	10
20-676	2-1/8 x 2-1/2	-330	10
20-677	2-1/4 x 2-5/8	-331	10
20-678	2-3/8 x 2-3/4	-332	10
20-679	2-1/2 x 2-7/8	-333	10
20-713	2-5/8 x 3"	-334	10
20-680	2-3/4 x 3-1/8	-335	10
20-681	2-7/8 x 3-1/4	-336	10
20-682	3" x 3-3/8	-337	10
20-956	3-1/8 x 3-1/2	-338	10
20-957	3-1/4 x 3-5/8	-339	10
20-958	3-5/8 x 4"	-342	10
20-959	3-3/4 x 4-1/8	-343	10
20-960	4" x 4-3/8	-345	10
20-961	4-1/8 x 4-1/2	-346	10
20-962	4-1/4 x 4-5/8	-347	10
20-963	4-3/8 x 4-3/4	-348	10
20-964	4-5/8 x 5"	-350	10
20-965	4-7/8 x 5-1/4	-352	10
20-966	5" x 5-3/8	-353	10
20-967	5-5/8 x 6"	-358	10
20-968	6-3/4 x 7-1/8	-364	10

Also available: neoprene, viton, silicone, thicknesses up to 1/2", diameters up to 100" ID, back-up "O" rings, "U" cups

## "O" Rings for Boss Thread Hydraulic Fittings

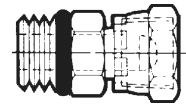

Part No.	Size I.D.	Thick-ness	Trade No.	Fitting Size	Pkg Qty
20-737	.3510	.072	-904	7/16-20 <sup>(-4)</sup>	50
20-738	.4140	.072	-905	1/2-20 <sup>(-5)</sup>	50
20-739	.4680	.078	-906	9/16-18 <sup>(-6)</sup>	50
20-740	.6440	.087	-908	3/4-16 <sup>(-8)</sup>	25
20-741	.7550	.097	-910	7/8-14 <sup>(-10)</sup>	25
20-742	.9240	.116	-912	1-1/16-12 <sup>(-12)</sup>	25
20-743	1.0408	.116	-914	1-3/16-12 <sup>(-14)</sup>	25
20-744	1.1710	.116	-916	1-5/16-12 <sup>(-16)</sup>	10
20-745	1.4750	.118	-920	1-5/8-12 <sup>(-20)</sup>	10
20-746	1.7200	.118	-924	1-7/8-12 <sup>(-24)</sup>	10
20-747	2.3370	.118	-932	2-1/2-12 <sup>(-32)</sup>	10



# Viton "O" Rings

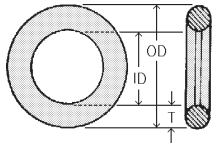

Viton compound withstands excessive heat and corrosive chemicals. Compatible with a wide variety of fluids and chemicals including diluted and concentrated acids, vegetable oils, synthetic lubricants, motor oils, hydrocarbon fuels, toluene, solvents and gases. Viton material is also ozone resistant. *Meets MIL-M6HK810A1-11B38EF31EO78EO16EO36Z1Z2. Class 1, Type II. Hardness is 75 ±5 Shore A durometer. Temperature range: -20°F to +400°F in continuous use, and up to +500°F for intermittent service. SAE standard sizes AS-568. Color: Brown.*

Part Number	Size ID x OD	Trade No.	Pkg Qty
<b>1/16" Thick (.070")</b>			
20-217	1/8 x 1/4	-006•	50
20-218	5/32 x 9/32	-007•	50
20-219	3/16 x 5/16	-008•	50
20-220	7/32 x 11/32	-009•	50
20-221	1/4 x 3/8	-010•	50
20-222	5/16 x 7/16	-011•	50
20-223	3/8 x 1/2	-012•	50
20-224	7/16 x 9/16	-013•	50
20-225	1/2 x 5/8	-014•	50
20-237	9/16 x 11/16	-015•	50
20-238	11/16 x 13/16	-017•	50
20-239	7/8 x 1"	-020•	50
<b>3/32" Thick (.103")</b>			
20-240	3/8 x 9/16	-110•	50
20-241	7/16 x 5/8	-111•	50
20-242	1/2 x 11/16	-112•	50
20-245	9/16 x 3/4	-113•	50
20-434	5/8 x 13/16	-114•	50
20-435	11/16 x 7/8	-115•	50
20-436	3/4 x 15/16	-116•	50
20-499	7/8 x 1-1/16	-118•	50
20-500	1" x 1-3/16	-120•	50
<b>1/8 Thick (.139")</b>			
20-501	3/4 x 1"	-210•	25
20-502	13/16 x 1-1/16	-211•	25
20-503	7/8 x 1-1/8	-212•	25
20-504	15/16 x 1-3/16	-213•	25
20-505	1" x 1-1/4	-214•	25
20-506	1-1/16 x 1-5/16	-215•	25
20-507	1-1/8 x 1-3/8	-216•	25
20-508	1-3/16 x 1-7/16	-217•	25
20-509	1-1/4 x 1-1/2	-218•	25
20-777	1-5/16 x 1-9/16	-219•	25
20-778	1-3/8 x 1-5/8	-220•	25
20-779	1-7/16 x 1-11/16	-221•	25
20-780	1-1/2 x 1-3/4	-222•	25
20-781	1-5/8 x 1-7/8	-223•	25
20-782	1-3/4 x 2"	-224•	25
<b>3/16 Thick (.210")</b>			
20-783	1-1/2 x 1-7/8	-325•	25
20-784	1-5/8 x 2"	-326•	25
20-785	1-3/4 x 2-1/8	-327•	25

• Sizes marked with bullet (•) included in assortment #10-677

# "O" Ring Tools

## "O" Ring Sizing Cone and Pi Tape

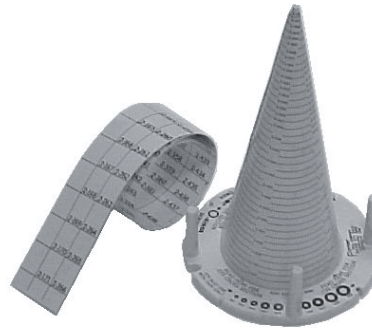

Easily determines the correct o-ring size and trade number. Measuring cone fits small sizes and pi tape fits large sizes up to 8" ID. **Part no. 20-1007**

## 2 Pc. Brass "O" Ring Tool Kit

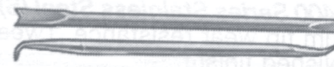

For O-ring installation and removal. Will not damage delicate parts. Length: 6". Plastic pouch. **Part No. 20-736**

## Steel "O" Ring Tool



Straight and right angle hardened steel tips. Knurled aluminum body. 8½" long. **Part No. 12-72443**

**YOU ORDER TODAY,  
WE SHIP TODAY!  
WHY WAIT?**



# "O" Ring Assortments, Cord Stock

**LOCTITE**

## "O" Ring Making Kit

Make any size o-ring right on the job-site. Contains 3 feet of each; 3/32", 1/8", 3/16", 1/4" diameter

Buna N rubber cord stock, splicing fixture, razor blade and instant adhesive, waterproof solvent and cleaning solvent in sturdy plastic box. **Part No. LT-00112**



*tech tip*

Razor blades are usually coated with silicone lubricant, the #1 enemy of instant adhesives. Before making an O-ring, clean the razor blade with solvent and make sure your hands are clean too.

## "O" Ring Cord Stock

Refills for O-ring making kits. Made from Buna-N 70 rubber compound.

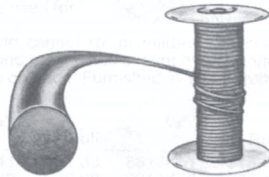

Part Number	Diameter	Pkg Qty
20-909	1/16	50'
20-910	3/32	50'
20-911	1/8	50'
20-912	3/16	50'
20-913	1/4	50'



**SAE "O" RING MAINTENANCE KIT**  
BUNA N RUBBER, 18 SIZES; 1/4"—1-3/16" OD. IN A CLEAR POLYSTYRENE BOX. **PART NO. 519MK**



**SAE "O" RING ASSORTMENT**  
INCLUDES 1/16, 1/8 & 3/16 DIAMETER BUNA N O-RINGS. 70 DUROMETER, SAE 120R CLASS 1. 24 SIZES; 1/4"—2-1/8" OD. LARGE STEEL DRAWER. **PART NO. 16-3524**

### ONE-DIAMETER "O" RING ASSORTMENTS

BUNA N, 70 DUROMETER, SAE 120R CLASS 1. LARGE STEEL DRAWER INCLUDED.

- 16-6232• ..... 1/16" O-RING ASST, 1/4 thru 2-3/8" OD, 246 pcs, 30 sizes
- 16-6324• ..... 1/32" O-RING ASST, 5/16 thru 1-11/16" OD 301 pcs, 24 sizes
- 16-6432• ..... 1/8" O-RING ASST, 3/4 thru 3-1/2" OD, 316 pcs, 32 sizes



**SAE "O" RING KIT**  
BUNA N RUBBER, 30 SIZES, 1/4"—2-1/8" OD. IN A POLYPROPYLENE BOX. **PART NO. 10-676**

**VITON RUBBER "O" RING KIT**  
RESISTS EXTREME TEMPERATURES AND CORROSIVE CHEMICALS. -65°F TO +500°F. 30 SIZES, 1/4"—2-1/8" OD. IN A POLYPROPYLENE BOX. **PART NO. 10-677**

**METRIC "O" RING KIT**  
BUNA N RUBBER, 36 SIZES; M5.4—M24 OD. IN A POLYPROPYLENE BOX. **PART NO. AV-15961**

*Kits also available in nitrile rubber (orange dot) and neoprene rubber (blue) for R12 and R134A refrigerant.*

**SAVE TIME BY LETTING US LOCATE THOSE HARD-TO-FIND ITEMS FOR YOU!**

# "O" Ring Sizer

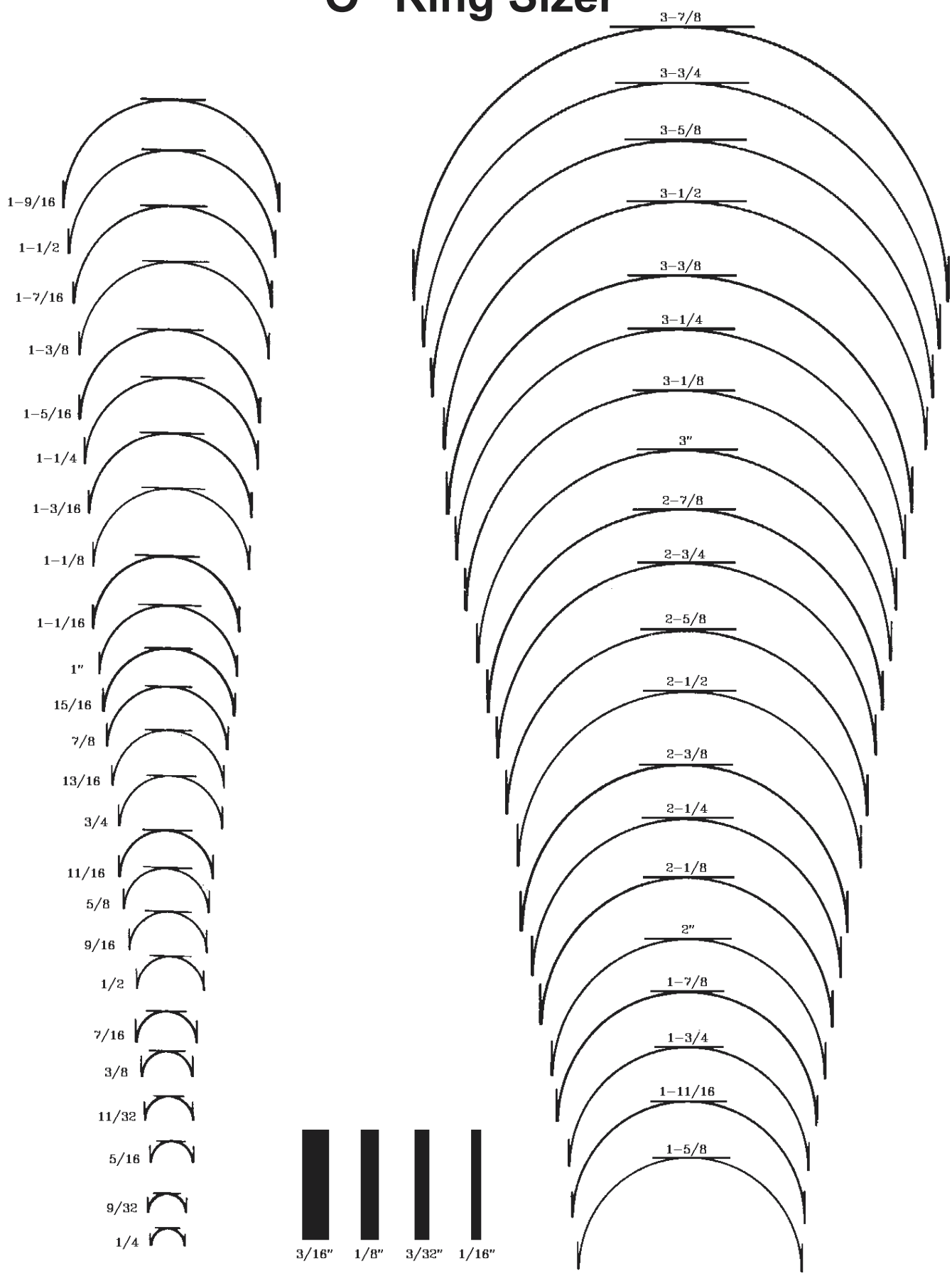



# Terminal Construction and Barrel Styles

Vinyl Insulated

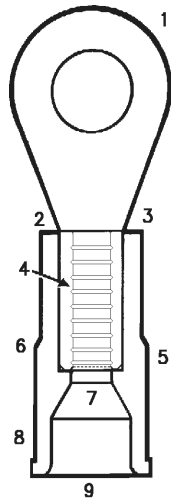

Nylon Insulated with Insulation Grip

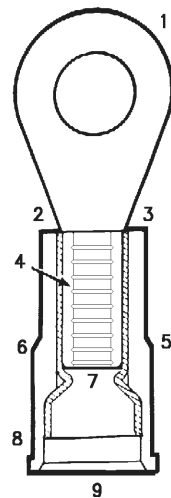

1. One-piece, burr free construction for maximum electrical conductivity-Electro-tin plating for maximum corrosion resistance. Annealed to relieve stress points and assure maximum installed strength.

2. Barrel-to-pad transition designed to minimize flexing and bending.

3. Open-end design permits visual inspection of wire location before and after crimping.

4. Multiple "V" grooves in #22-4 AWG parts for maximum holding power and current flow.

5. Injection Molded insulations provide the highest quality terminals in the industry.

- 105°C rated, tough, resistant electrical grade materials.

- Molding insures consistent wall thickness for maximum reliability after crimping

- Molding affords Funnel Barrel construction for easier installation.

- Molding offers the crimp ridge and nonslip ridge.

6. Crimp ridge designed for positive location of tool on terminal barrel which means fewer mis-crimps.

7. Funnel Barrel construction provides excellent electrical and mechanical connections.

- Positive and easy wire insertion.

- Eliminates strand hang-ups.

- No wire twisting necessary.

- Insures good crimp contact and electrical conductivity.

- Nylon-insulated terminals feature a brass sleeve for optimum grip on insulation, strain relief and vibration protection. Sleeve is recessed for excellent flashover protection.

8. Nonslip ridge so tool slides to end of terminal for proper crimp and better workmanship.

9. Beveled leading edge for easy insulation entry.

## Standard Crimp Terminal and Connector Specifications

Materials; Crimp terminals and connectors are to be burr-free, annealed and tin-plated ETP copper. Barrels shall be .25" long with brazed seams where specified. Insulation grip sleeves are to be tin-plated brass and attached securely to the barrel. Terminal insulators are to be molded polyvinyl chloride or nylon and be UL Listed and CSA Certified for 600 V. and 105°C. Connector insulators are to be extruded polyvinyl chloride or nylon with the same ratings.

Construction; All insulated terminals are to have funnel entry construction to prevent strand hang-up and a crimp ridge for proper tool location. Nylon insulated terminals and connectors are to have butted seam barrels with insulation grip sleeves. All terminal barrels are to have multiple "V" grooves for maximum conductor retention.

Insulators; Color-coded red (22-18), blue (16-14) yellow (12-10), red (8), blue (6) and yellow (4) for conductor sizes.

**Funnel barrel feature provides excellent electrical and mechanical connection.**

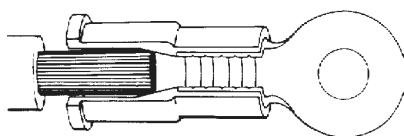

1. Funnel design guides wire into position.

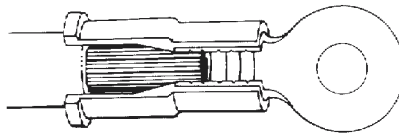

2. No wire strand hang-up as wire is inserted. Fast, positive installation.

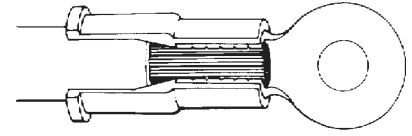

3. Wire in place ready for crimping.



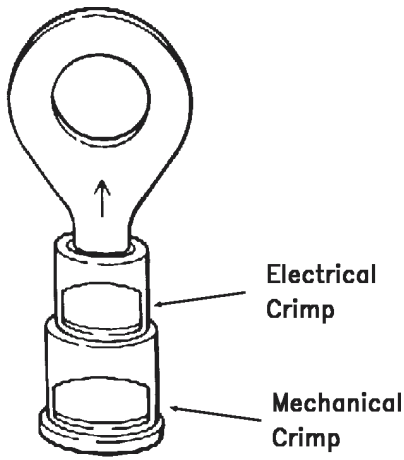

**NYLON INSULATED BUTTED SEAM WITH INSULATION GRIP**

Used where insulated barrel and positive insulation grip are necessary or desirable. Terminal consists of butted seam part with flared, seamless brass sleeve securely attached and covered with flared, molded nylon sleeve. Wire insulation positions itself against funnel portion of brass sleeve. Crimping barrel provides excellent electrical contact. Insulation grip provides additional stress relief at junction of insulation and barrel. Positioning crimp tool is nearly mistake proof due to a "step" in nylon insulation. Industry standard color coding indicates wire range. Insulators are rated at a continuous operating temperature range from -60° F to 221° F (-55° C to 105° C) U.L. Listed and CSA Certified for 600 volt building wire and 1000 volt signs and fixtures. Body made from the highest grade electrolytic copper.

**VINYL INSULATED BUTTED SEAM**

Used where insulated barrel is necessary and desirable. Terminal consists of butted part with flared, rigid, molded polyvinyl chloride sleeve securely attached and funneled for easy wire entry. Wire insulation positions itself against funnel portion of vinyl sleeve thus eliminating strand hang-up. Crimping barrel provides excellent electrical contact. Insulation prevents vibration damage by not allowing wire flex at point of crimp. Insulation has a nonskid ridge for ease of positioning crimping tool. Industry standard color coding indicates wire range. Insulators are rated at a continuous operating temperature range from -40° F to 194° F (-40° C to 90° C). U.L. Listed and CSA Certified for 600 volt building wire and 1000 volt signs and fixtures. Body made from the highest grade electrolytic copper.

**NON-INSULATED BUTTED SEAM**

The most economical terminal-used where special performance or installation characteristics are not needed. Beveled mouth facilitates wire insertion. Body made from the highest grade electrolytic copper.

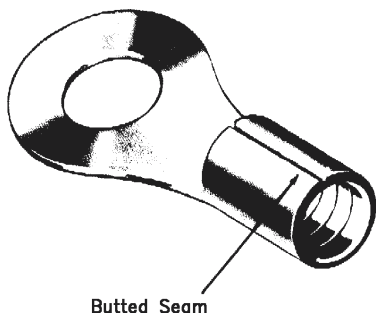

**HIGH TEMPERATURE NON-INSULATED BUTTED SEAM**

Same features as above, except material is nickel plated alloy steel. Designed withstand temperatures to 900° F (482° C).



**CRIMPING BUTTED SEAM CONNECTORS**



CORRECT



INCORRECT

# Krimp 'N Seal

## All-Weather, Heat-Sealable Terminals

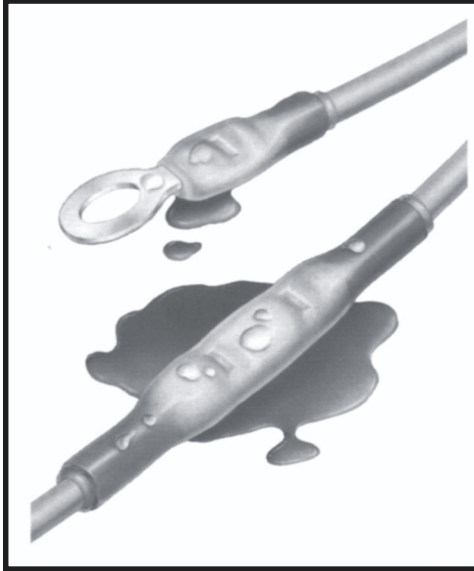

Krimp 'N Seal provides a rugged, environmentally-sealed connection for wire sizes 22-10 AWG that will insulate, seal, and protect joints from physical abuse and abrasion, water, salt, and other corrosive compounds.

### Waterproof adhesive seal

The inner wall of the heat shrinkable nylon tubing is lined with a special hot-melt adhesive which is inert at room temperature permitting wires to be inserted easily. As the sleeve is heated, the adhesive melts and flows under pressure from the tubing. This action fills any existing voids and creates a seal which repels moisture.

### Tough and durable

Krimp 'N Seal will stand up to the most rigorous tests that can be applied to high-performance splices. The tough nylon tubing resists abrasion and cutting. Exceeds all UL, CSA, and MIL Spec requirements. Dielectric strength: 7.51 kV

### Temperature stability

Krimp 'N Seal splices remain supple and impact-resistant long after other nylon insulations become brittle and subject to cracking. Temperature rating: -55°C to 125°C.

### Lower profile

Krimp 'N Seal splices are smaller and lighter than most comparable wire splices; a very important advantage when space and weight savings are critical in high-density applications



*Butt Connectors*

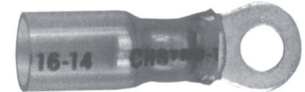

*Ring Terminals*



*Spade Terminals*

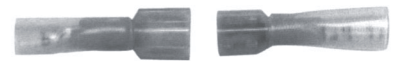

*Quick Disconnect Terminals*



*New Step-Down Butt Connectors*

### Versatile

The Krimp 'N Seal sleeve has a funnel-entry opening that accommodates thick wire insulations but will shrink to less than half its original diameter to seal thin insulations effectively.

## EASY 1-2-3 INSTALLATION

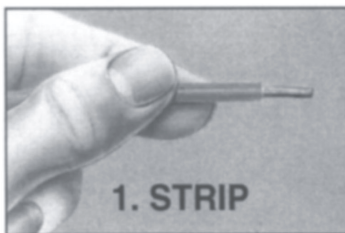

1. First select the appropriate size splice for the wire gauge. Strip the wires 0.3" (5/16") from the ends and insert into the crimp barrel until seated.

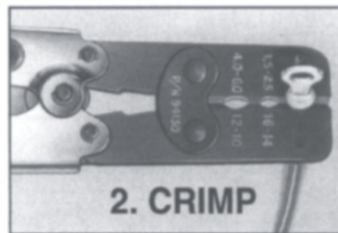

2. Then make the crimp connection using a tool designed for insulated splices.

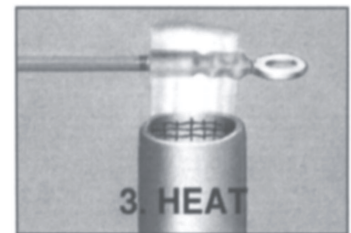

3. With hot air gun or other heat source, apply heat directly to the splice, working from the center out to the edges, until the tubing recovers and the adhesive flows. Allow to cool before inspecting or checking the integrity of the splice.



# ElektraLink™

## SEALED & SOLDERED CONNECTORS!

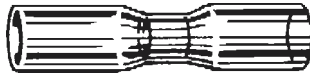

### THE PERFECT ALL-WEATHER CONNECTION!

Elektralink™ electrical terminals provide a fast, easy, reliable and moisture resistant way to complete sealed in-line wire splices. Each connection solders, insulates, encapsulates and relieves wire strain for wires from 24 AWG to 10 AWG. When heated with a flame or heat gun, the sleeve shrinks and the solder melts and flows resulting in the *perfect* connection.

- No crimping tool required.
- Low-temp fluxed solder ring melts with a standard heat gun, lighter or match.
- Tough, multiple wall tubing adhesive inner melt liner protects connection.
- See-thru, color-coded tubing allows visual inspection.
- No skill required.
- Thick, 100% copper body is electro-tin plated for solderability.
- Extra long barrels for better contact.

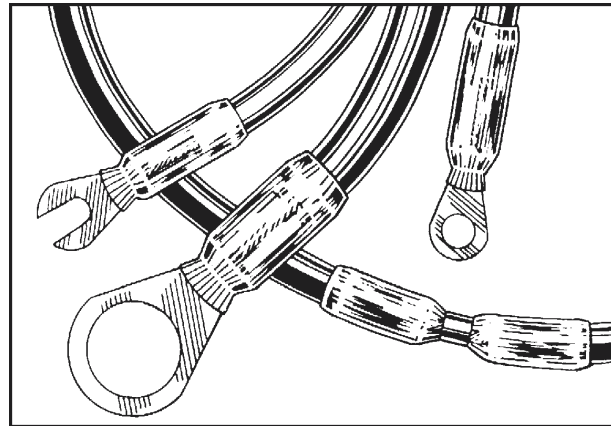

### PRODUCT CHARACTERISTICS

Typical properties for the installed splice.

Temperature Rating: ..... -65° to 275°F  
Dielectric Strength: ..... 15 kV  
Voltage Drop: ..... Less than equal length of wire  
Insulation Resistance: .... 1014 Megohms  
Military Spec. (tubing) .... MIL-I-23053/4 Class 1 AMS-3624  
Military Spec. (solder) .... QQ55771E, MIL-S-14256

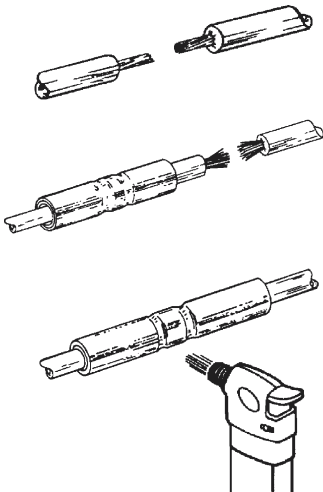

#### INSTALLING BUTT CONNECTORS

1) Strip wire ends 3/8". 2) Slide splice over one end. 3) Separate wire strands. 4) Push both ends together to intermingle wire. 5) Slide splice over joined wires. 6) Heat tubing from the center out to ends, then focus heat on solder until it flows.

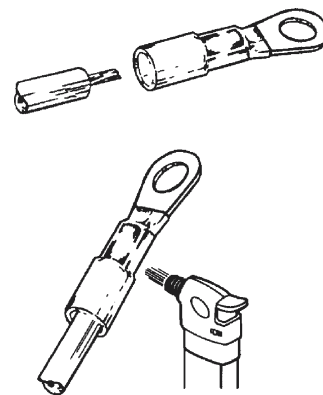

#### INSTALLING RING & SPADE TERMINALS

1) Strip wire ends 3/8". Do not touch wire strands with fingers. 2) Insert wire into terminal, resting exposed strands in the open barrel. 3) In an almost upright position, heat the BASE of the terminal. Try to distribute heat evenly by rotating the terminal. 4) Remove the terminal from the heat source when the solder visibly flows around the wire strands.

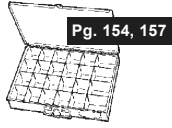





# Ring Terminals

	Wire Range	Stud Size	Nylon Insulated	Vinyl Insulated	Non-Insulated	High Temp. Non-Insulated	Krimp-N-Seal	Elektra-Link™
	22-18	4-6	02-001	02-030	02-200	02-270	02-035 <sub>(50)</sub>	02-322 <sub>(50)</sub>
	RED							
	22-18	8-10	02-002	02-031	02-201	02-271	02-036 <sub>(50)</sub>	02-324 <sub>(50)</sub>
	RED							
	22-18	12-14	02-003	-	02-202	-	02-037 <sub>(50)</sub>	02-325 <sub>(50)</sub>
	RED							
	22-18	3/8	02-004	-	-	-	-	-
	RED							
	16-14	4-6	02-040	02-075	02-208	02-272	-	-
	BLUE							
	16-14	8-10	02-041	02-076	02-209	02-273	02-038 <sub>(50)</sub>	02-328 <sub>(50)</sub>
	BLUE							
	16-14	12-1/4	02-042	02-077	02-210	02-274	02-039 <sub>(50)</sub>	02-329 <sub>(50)</sub>
	BLUE							
	16-14	5/16	02-043	-	-	-	-	-
	BLUE							
	16-14	3/8	02-044	-	-	-	02-167 <sub>(50)</sub>	02-330 <sub>(50)</sub>
	BLUE							
	12-10	4-6	02-090 <sub>(50)</sub>	-	-	02-275	-	-
	YELLOW							
	12-10	8-10	02-091 <sub>(50)</sub>	02-120	02-223	02-276	02-168 <sub>(50)</sub>	02-332 <sub>(50)</sub>
	YELLOW							

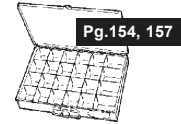
Pkg: 100 each (unless marked otherwise)

# Ring Terminals

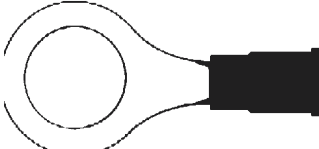

	Wire Range	Stud Size	Nylon Insulated	Vinyl Insulated	Non-Insulated	High Temp. Non-Insulated	Krimp-N-Seal	Elektra-Link™
	12-10	12-1/4	02-092 <sub>(50)</sub>	02-121	02-224	02-277	02-169 <sub>(50)</sub>	02-333 <sub>(50)</sub>
	YELLOW							
	12-10	5/16	02-093 <sub>(50)</sub>	-	02-225	-	-	-
	YELLOW							
	12-10	3/8	02-094 <sub>(50)</sub>	02-122	02-226	02-278	02-170 <sub>(50)</sub>	02-334 <sub>(50)</sub>
	YELLOW							
	12-10	1/2	02-095 <sub>(50)</sub>	-	02-227	-	02-171 <sub>(50)</sub>	02-335 <sub>(50)</sub>
	YELLOW							

Pkg: 100 each (unless marked otherwise)

## Multi-Stud Ring Terminals

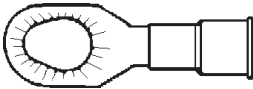

Reduce your terminal inventory! Tapered stud hole is designed to hold tightly on different stud sizes. One terminal can do the job of several. Made of tin plated copper. Nylon insulated with insulation grip.

Wire Range	Stud Size	Color Code	Part Number	Pkg Qty
22-18	2-4-6	Red	02-006	100
22-18	6-8-10	Red	02-007	100
16-14	2-4-6	Blue	02-045	100
16-14	6-8-10	Blue	02-046	100
12-10	6-8-10	Yellow	02-096	50

## Trailer Pin Connectors

Use for positive connections on trailer connectors and terminal blocks.

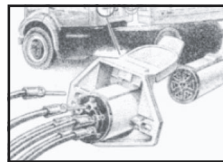

Trailer pins allow set screw to bite the pin instead of directly to fragile stranded wire. Nylon insulated with insulation grip.

Part No.	Wire Range	Color	Pin Diam.	Pkg Qty
02-186	22-18	Red	.030"	100
02-187	16-14	Blue	.030"	100
02-188	12-10	Yellow	.040"	50

# Large Ring Terminals

Pkg: 25 each

8 AWG WIRE RANGE			6 AWG WIRE RANGE			4 AWG WIRE RANGE		
Stud Size	RED Insulation	Non-Insulated	Stud Size	BLUE Insulation	Non-Insulated	Stud Size	YELLOW Insulation	Non-Insulated
8-10	02-130	02-230	8-10	02-136	-	8-10	02-142	-
1/4	02-131	02-231	1/4	02-137	02-235	1/4	02-143	02-239
5/16	02-132	-	5/16	02-138	-	5/16	02-144	-
3/8	02-133	02-232	3/8	02-139	02-236	3/8	02-145	02-240
1/2	02-134	02-233	1/2	02-140	02-237	1/2	02-146	02-241

**WE MAKE  
BATTERY CABLES**







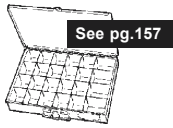

Custom-crimped battery cables made to your specifications. Give us a call!

Herbert Hoover was the first U.S. president to have a telephone on his desk. Prior to 1929, the president used a telephone booth outside his office.





# Spade Terminals

Wire Range	Stud Size	Nylon Insulated	Vinyl Insulated	Non-Insulated	High Temp. Non-Insulated	Krimp-N-Seal	Elektra-Link™
 22-18	4-6	02-008	02-032	02-203	-	-	-
RED							
 22-18	8-10	02-009	02-033	02-204	-	02-172 <sub>(50)</sub>	02-326 <sub>(50)</sub>
RED							
 16-14	4-6	02-047	02-078	02-211	-	-	-
BLUE							
 16-14	8-10	02-048	02-079	02-212	-	02-173 <sub>(50)</sub>	02-331 <sub>(50)</sub>
BLUE							
 12-10	4-6	02-097 <sub>(50)</sub>	-	-	-	-	-
YELLOW							
 12-10	8-10	02-098 <sub>(50)</sub>	02-123	02-228	-	02-174 <sub>(50)</sub>	02-336 <sub>(50)</sub>
YELLOW							

Pkg: 100 each (unless marked otherwise)

## Snap Spade Terminals



Snaps onto stud for hands-free installation.  
Nylon insulated with insulation grip.

Wire Range	Stud Size	Color Code	Part Number	Pkg Qty
22-18	6	Red	02-010	100
22-18	8	Red	02-011	100
22-18	10	Red	02-012	100
16-14	6	Blue	02-049	100
16-14	8	Blue	02-050	100
16-14	10	Blue	02-051	100
16-14	1/4	Blue	02-052	100
12-10	8	Yellow	02-099	50
12-10	10	Yellow	02-100	50
12-10	1/4	Yellow	02-101	50

## Hook Terminals



Nylon insulated with insulation grip.

Wire Range	Stud Size	Color Code	Part Number	Pkg Qty
22-18	4-6	Red	02-013	100
22-18	8-10	Red	02-014	100
16-14	4-6	Blue	02-053	100
16-14	8-10	Blue	02-054	100
12-10	8-10	Yellow	02-102	50

**Whose cruel idea was it  
for the word "lisp" to  
have an "s" in it?**



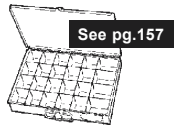

# Butt Connectors



## Nylon Insulated with "Insulation Grip"

Mechanical insulation grip eliminates failure due to vibration. Doubles crimp integrity. Heavy duty, seamless, extra long barrel with funnel wire entry. 600V rating.

Wire Range	Color	Part Number	Pkg Qty
22-18	Red	02-022	100
16-14	Blue	02-072	100
12-10	Yellow	02-113	100



## Nylon Insulated

Heavy duty, seamless, extra long barrel. Translucent insulation for easy visual inspection. 600V rating.

Wire Range	Color	Part Number	Pkg Qty
22-18	Red	02-005	100
16-14	Blue	02-065	100
12-10	Yellow	02-110	100



## Vinyl Insulated

Butted seam. Molded vinyl funnel entry. 600V rating.

Wire Range	Color	Part Number	Pkg Qty
22-18	Red	02-034	100
16-14	Blue	02-082	100
12-10	Yellow	02-124	100
8	Red	02-135	25
6	Blue	02-141	25
4	Yellow	02-147	25



## Nylon 3-Way Connectors

With insulation grip

Wire Range	Color	Part Number	Pkg Qty
22-18	Red	02-027	25
16-14	Blue	02-070	25
12-10	Yellow	02-111	25

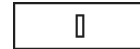

## Non-Insulated

**Standard:** high grade electrolytic copper, seamless.

**Hi-temp:** nickel plated alloy steel, butted seam, withstands temperatures to 900°F

Wire Range	Part Number		Pkg Qty
	Standard	Hi-Temp	
22-18	02-205	02-281	100
16-14	02-213	02-282	100
12-10	02-229	02-283	100
8	02-234		25
6	02-238		25
4	02-242		25



New Step-Down Butt Connector

## Krimp-N-Seal

Crimp connector, then seal heat shrink tubing with hot air gun or another heat source for an all weather connection. High grade electrolytic copper, seamless barrel. **NEW STEP-DOWN SIZES!**

Wire Range	Color	Part Number	Pkg Qty
<i>Butt Connector</i>			
22-18	Red	02-029	50
16-14	Blue	02-074	50
12-10	Yellow	02-115	50
<i>Step-Down Butt Connector</i>			
22-18 to 16-14	Red	02-108	50
16-14 to 12-10	Blue	02-109	50
12-10 to 8	Yellow	02-118	50

## ElektraLink™

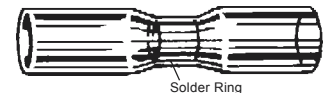

Solder Ring

### NO CRIMPING!

An all-weather *sealed and soldered* splice. Seal the heat-shrink tubing with hot air gun or other heat source, then focus heat on solder until it flows for a perfect splice every time!

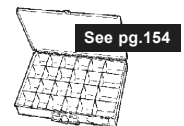

Wire Range	Color	Part Number	Pkg Qty
20-24	Clear	02-318	50
18-20	Red	02-319	50
16-14	Blue	02-320	50
12-10	Yellow	02-321	50



# ElektraLink™ Terminal Assortments



**ELEKTRALINK™ SOLDER TERMINAL ASSORTMENT**  
19 SIZES, 20-10 GA. BUTT, RING AND SPADE TERMINALS  
IN A LARGE STEEL DRAWER. **PART NO. 16-2024**



**ELEKTRALINK™ SOLDER TERMINAL MAINTENANCE KIT**  
6 SIZES, 20-10 GA. BUTT AND RING TERMINALS IN PLASTIC BOX.  
**PART NO. 542MK**

# Star Ring Grounding Terminals

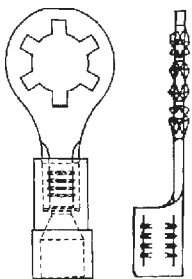

Steel serrated ring terminal pierces through paint and other coatings and bites into metal to insure a good connection or ground. Use especially where high vibration exists. Eliminates the need for lockwashers.

*Nylon insulated with insulation grip.  
Tin plated steel ring.*

Part No.	Wire Gauge	Insulation Color	Stud Size	Pkg Qty
02-180	22-18	Red	6	100
02-181	22-18	Red	8	100
02-182	22-18	Red	10	100
02-183	16-14	Blue	6	100
02-184	16-14	Blue	8	100
02-185	16-14	Blue	10	100

# Posi-Lock™ No-Crimp Connectors

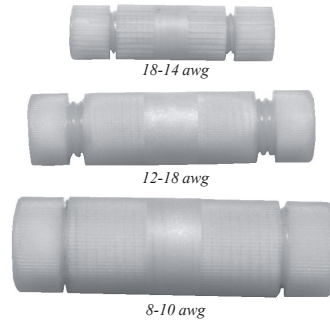

- 4 Times Stronger Than Crimp Connectors
- Makes Multiple Splice Connections
- High Temperature And Chemical Resistant
- Reusable And Reconnectable

The truly amazing Posi-Lock™ no-crimp connector is unique in every way. It will not pull apart, will not vibrate loose and will not melt down. Connector material: Nylon type 6/6. Bullet material: tin plated brass. Made in U.S.A. Approvals: GM# 12346377, U.S. Air Force, UL listed 37CL 600 VAC†.

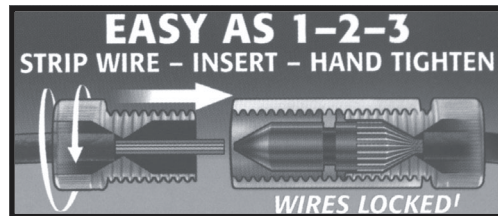

Wire Range	Part Number	Pkg Qty
18-24 awg	02-395	25
12-18 awg	02-396	25
8-10 awg	02-397	12

† For AC/DC stranded wire applications only.



**POSI-LOCK™ CONNECTOR KIT**  
3 SIZES, 24-8 GA. WIRE RANGE IN PLASTIC BOX.  
**PART NO. 548MK**

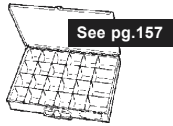

# Quick Slide Terminals

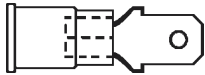

## Insulated Male Quick Slide Terminals

with insulation grip (nylon only)

Wire Range	Tab Width	Color	Nylon Insulated	Vinyl Insulated	Pkg Qty
22-18	.187 (3/16)	Red	02-015	-	100
22-18	.250 (1/4)	Red	02-016	-	100
16-14	.187 (3/16)	Blue	02-055	-	100
16-14	.250 (1/4)	Blue	02-056	02-080*	100
12-10	.250 (1/4)	Yellow	02-103	-	50

\* no insulation grip



## Insulated Female Quick Slide Terminals

with insulation grip (nylon only)

Wire Range	Tab Width	Color	Nylon Insulated	Vinyl Insulated	Pkg Qty
22-18	.187 (3/16)	Red	02-017	-	100
22-18	.250 (1/4)	Red	02-018	-	100
16-14	.110 (1/8)	Blue	02-057	-	100
16-14	.187 (3/16)	Blue	02-058	-	100
16-14	.250 (1/4)	Blue	02-059	02-081*	100
12-10	.250 (1/4)	Yellow	02-104	-	50
12-10	.375 (3/8)	Yellow	02-105	-	50

\* no insulation grip

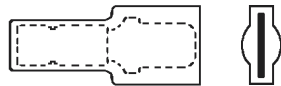

## Nylon Fully Insulated Male Quick Slide Terminals

with insulation grip. 3M style shown above†.

Wire Range	Tab Width	Color	Part Number	Pkg Qty
22-18	.250 (1/4)	Red	02-019	100
16-14	.250 (1/4)	Blue	02-060	100
12-10	.250 (1/4)	Yellow	02-106	50

†FOR ONE FLAT SIDE DESIGN ADD "F" TO PART NUMBER.

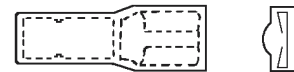

## Nylon Fully Insulated Female Quick Slide Terminals

with insulation grip. 3M style shown above†.

Wire Range	Tab Width	Color	Part Number	Pkg Qty
22-18	.250 (1/4)	Red	02-020	100
16-14	.250 (1/4)	Blue	02-061	100
12-10	.250 (1/4)	Yellow	02-107	50

†FOR ONE FLAT SIDE DESIGN ADD "F" TO PART NUMBER.

## Krimp-N-Seal Quick Slide Terminals

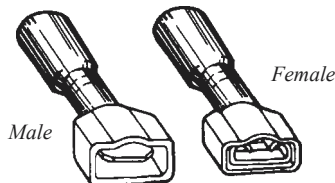

Crimp connector, then seal heat shrink tubing with hot air gun or another heat source for an all weather connection. High grade electrolytic copper.

Tab width: .250 (1/4)

Wire Range	Color	Part Number		Pkg Qty
		Male	Female	
20-18	Red	02-449	02-448	50
16-14	Blue	02-451	02-450	50
12-10	Yellow	02-453	02-452	50

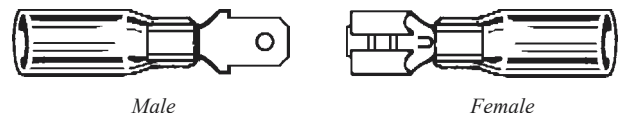

## ElektraLink™ Quick Slide Terminals

**NO CRIMPING!** An all-weather *sealed-soldered* connection. Seal heat-shrink tubing with hot air gun or other heat source, then focus heat on solder until it flows. Tab width: .250 (1/4)

Wire Range	Color	Part Number		Pkg Qty
		Male	Female	
20-18	Red	02-389	02-390†	50
16-14	Blue	02-391	02-392†	50
12-10	Yellow	02-393	02-394†	50

†FOR FULLY INSULATED (FEMALE ONLY) ADD "F" TO PART NUMBER.



# Quick Slide Terminals



Male



Female

## Non-Insulated Quick Slide Terminals

Wire Range	Style	Tab Width	Part Number	Pkg Qty
<i>Non-Insulated</i>				
16-14	Male	.187 (3/16)	02-217	100
16-14	Male	.250 (1/4)	02-218	100
16-14	Female	.187 (3/16)	02-219	100
16-14	Female	.250 (1/4)	02-220	100
<i>High Temperature</i>				
16-14	Male	.250 (1/4)	02-279	100
16-14	Female	.250 (1/4)	02-280	100



Male Snap Plug



Female Snap Receptacle

## Snap Plugs & Receptacles

Nylon Insulated w/Insulation Grip & Non-Insulated.

Wire Range	Snap Dia.	Nylon Insulated	Non-Insulated	Part Number	Pkg Qty
<i>Male Snap Plugs</i>					
22-18	.157	02-023	-		100
22-18	.176	02-024	-		100
16-14	.157	02-066	02-214		100
16-14	.176	02-067	02-215		100
<i>Female Snap Receptacles</i>					
22-18	.157	02-025	-		100
22-18	.176	02-026	-		100
16-14	.157	02-068	-		100
16-14	.176	02-069	-		100

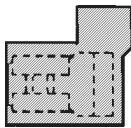

Nylon Insulated

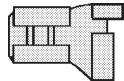

Non-Insulated

## Female Flag Quick Disconnects

Wire Range	Tab Width	Nylon Insulated	Non-Insulated	Pkg Qty
22-18	.187 (3/16)	02-175	02-206	100
22-18	.250 (1/4)	02-176	02-207	100
16-14	.187 (3/16)	02-177	02-221	100
16-14	.250 (1/4)	02-178	02-222	100

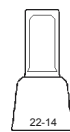

22-14



16-10

## Nylon Insulated Pigtails

Also called closed-end connectors. Pictured actual size.

Wire Size	Part No.	Pkg Qty
22-14	02-116	100
16-10	02-117	100

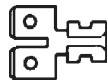

## Double Male-Female Adapters

Tab width: .250" (1/4)

Part No.	Pkg Qty
02-086	100



## Double Male-Female Adapters

Tab width: .250" (1/4)

Part No.	Pkg Qty
02-087	100



## Multi-Stack Disconnects

Wire Range	Nylon Insulated	Non-Insulated	Pkg Qty
16-14	02-063	02-216	100

.250" tab width



## Open Barrel Female Quick Slides

Wire Range	Tab Width	Part No.	Pkg Qty
16-14	.250 (1/4)	02-089	100

Mates with 02-088



## Open Barrel Male Quick Slides

Wire Range	Tab Width	Part No.	Pkg Qty
16-14	.250 (1/4)	02-088	100

Mates with 02-089

# Electrical Terminal Assortments



**KRIMP 'N SEAL TERMINAL ASSORTMENT**  
16 SIZES, 22 GA. - 10 GA. HEAT-SHRINKABLE BUTT CONNECTORS, QUICK DISCONNECTS & RING TERMINALS, IN A LARGE STEEL DRAWER. **PART NO. 16-5521**

(SPACE PROVIDED FOR OPTIONAL CRIMPING TOOL)



**NYLON TERMINAL ASSORTMENT**  
24 SIZES, 22 GA. - 10 GA. BUTT CONNECTORS, QUICK DISCONNECTS, RING & SPADE TERMINALS, CLOSED END CONNECTORS, AND BLUE INLINE SCOTCH-LOK CONNECTORS IN A LARGE STEEL DRAWER. **PART NO. 16-3824**

**BLUE NYLON TERMINAL MAINTENANCE KIT** 9 SIZES, ALL 16-14 BUTT CONNECTORS, QUICK DISCONNECTS, RING & SPADE TERMINALS, AND BLUE INLINE SCOTCH-LOK CONNECTORS. **PART NO. 523MK**



**NYLON TERMINAL MAINTENANCE KIT** 12 SIZES, 22 GA. - 10 GA. BUTT CONNECTORS, QUICK DISCONNECTS, RING & SPADE TERMINALS. **PART NO. 524MK**



**VINYL TERMINAL MAINTENANCE KIT** 9 SIZES, 22 GA. - 10 GA. BUTT CONNECTORS, QUICK DISCONNECTS, T-TAP CONNECTORS. **PART NO. 531MK**



**VINYL TERMINAL MAINTENANCE KIT** 9 SIZES, 22 GA. - 10 GA. BUTT CONNECTORS, QUICK DISCONNECTS, RING & SPADE TERMINALS, BLUE INLINE SCOTCH-LOK CONNECTORS. **PART NO. 530MK**



**NYLON TERMINAL ASSORTMENT** 24 SIZES, 22 GA. - 10 GA. BUTT CONNECTORS, FULLY INSULATED QUICK DISCONNECTS, RING & SPADE TERMINALS, INS. FLAG QUICK DISCONNECTS, AND BLUE INLINE SCOTCH-LOK CONNECTORS AND T-TAP QUICK DISCONNECTS IN A LARGE STEEL DRAWER. **PART NO. 16-3724**



**VINYL TERMINAL ASSORTMENT** 20 SIZES, 22 GA. - 10 GA. BUTT CONNECTORS, QUICK DISCONNECTS, RING & SPADE TERMINALS AND BLUE INLINE SCOTCH-LOK CONNECTORS IN A LARGE STEEL DRAWER. **PART NO. 16-0520**

Also see Posi-Lock™ and ElektraLink™ Assortments on pg. 154.



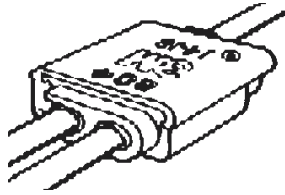

# Moisture Resistant Tap Connectors - Gel Filled

(Insulation Displacement Connectors)

**LONGER LASTING** • The patented Scotchlok™ MRT system forces a *protective gel* around the wire and element, providing a moisture-resistant barrier to destructive substances such as salt water and other corrosive environments. The double hinged cover seals out the elements. Special locking feature of the cover insures a protected connection over time.

**APPLICATIONS** • Used in making tap connections where protection from the environment is a benefit. Applications include wiring in trucks, cars, recreational vehicles, snowmobiles, motorcycles, boats, trailers, and off-road vehicles. The same benefits can also be achieved for outdoor lighting and landscaping.

**FAST! EASY TO USE!** • Eliminates the need to tape or insulate by forcing a protective gel around the element/conductor interface at the time the connection is made. Does not require cutting or stripping of wire - and they make better connections easier and faster.

1) Insert the run wire...

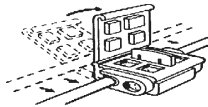

2) Insert the tap wire...

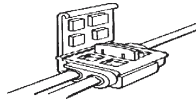

3) Crimp the element...

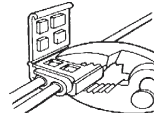

4) Close cover.

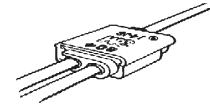

## TEMPERATURE RANGE

Continuous operating temperature: -40°F to 167°F (-40°C to 75°C).  
Install in temperatures as low as 0°F (-18°C).

Part No.	Color	Wire Range	Pkg Qty
02-337	Blue	18-14	50

# Female T-Tap Connectors

Installed Female T-Tap Connector

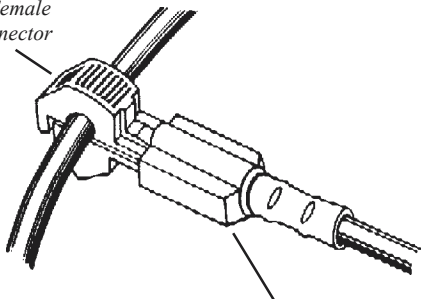

Mates with all 1/4" wide blade male disconnects.

T-Tap Quick Slides enable mid-span connection without stripping insulation. Installs with common pliers so no special tools are necessary. Provides fully-insulated connection when used with fully-insulated male quick-slides. Easy to disconnect. Female end mates with all 1/4" male blades. Self-stripping feature speeds installation, reduces possible conductor damage, eliminates time consuming mid span tap. Provides a circuit test point.

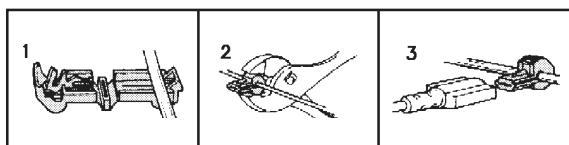

Part No.	Color	Wire Range	Pkg Qty	Mates with†
02-028	Red	22-18	50	02-019
02-073	Blue	18-14	50	02-060
02-114	Yellow	12	50	02-106

†Mates with fully insulated male quick disconnects.

# 3M Self-Stripping Pigtail Connectors

## Sealant-Filled

(Insulation Displacement Connector)

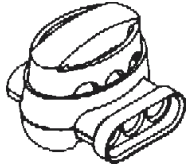

Labor saving technology installers demand. Saves time and cuts costs. Use to connect two or three wire ends and insulate the connection. Special sealant provides a moisture-resistant seal, protects against corrosion and damp conditions. Flame retardant. Easy to use; insert 2 or 3 wires completely into the connector and drive cap down with pliers. Used for stranded wire applications.

Wire Gauge	Color	Part Number	Pkg Qty
22-14	White w/blue cap	02-179	50

# 3M Self-Stripping Electrical Connectors

(Insulation Displacement Connector)

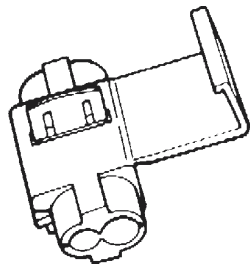

Easy-to-use, time saving connector. No special tools required. To install one, just squeeze - no stripping or twisting. Unique "U" contacts provide dependable electrical connections. Use on stranded or solid wire for in-line, pigtail, and tap splices. Color-coded polypropylene insulation. UL listed and CSA certified for **600 volts**<sup>1</sup>. Made in U.S.A.

Part No.	Color	Wire Range	Range	Pkg
02-150	Red	22-18	18-14	50
02-151	Blue	18-14	18-14	50
02-149 <sup>2</sup>	White	18-14	18-14	50
02-152	Brown	18-14	12-10	50
02-153	Yellow	12-10	12-10	50
02-154	Black	157	18-14	50

All sizes available in bulk. <sup>1</sup>02-149 is not UL listed or CSA certified. <sup>2</sup>02-149 has open ports to tap 2-wire runs.

# Split Bolt Connectors

Use for tapping, paralleling, and dead-ending electrical systems. For use with solid copper wires. Silicon bronze alloy. UL listed. CSA certified. (MCM = 1000 circular mils)

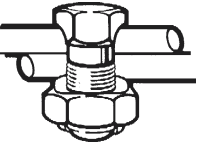

Part No.	Max. Wire Size	Pkg Qty
02-338	10 Stranded	5
02-339	8 Stranded	5
02-340	6 Solid	5
02-341	4 Solid	5
02-342	2 Stranded	5
02-343	1/0 Stranded	5
02-344	2/0 Stranded	5
02-345	3/0 Stranded	5
02-346	4/0, 250MCM Stranded	5

# 3M Electrical Spring Connectors

(Original Scotchlok Connector)

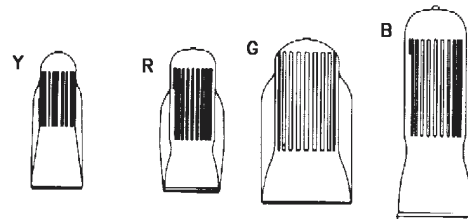

Here are the color-coded wire connectors electricians request. Scotchloks are flexible, yet durable with an outer insulator that gives you a compact, fully insulated connection that won't cut or abraid wires. The Y, R, and G torque fins provide a comfortable, secure grip. Crush-proof steel inner shell permits spring expansion and contraction due to temperature changes. Deep, flexible skirt protects against shorts and let connector bend with the wires you're splicing to fit easily into tight places. Rugged live-action spring wire. Vibration resistant and reusable. Meets federal spec. W-S-610, UL listed and CSA certified for **600 volts**.

Part No.	Color	Wire Range	Trade No.	Pkg
02-155	Yellow	22-10	Y	100
02-156	Red	18-10	R	100
02-157	Gray	14-8	G	100
02-158	Blue	12-6	B	50

Part No.	Wire Combinations
02-155	Min. 2, #18 ..... Max. 3, #14
02-156	Min. 3, #14 ..... Max. 3, #18
02-157	Min. 3, #12 ..... Max. 4, #10
02-158	Min. 3, #10 ..... Max. 3, #8







# Heavy Duty Primary Wire

**Oil & Grease Resistant**  
**Suitable for Wet or Dry Applications**  
**Withstands Temperature Extremes**

UL/CSA rated single conductor copper stranded PVC (polyvinyl-chloride) insulated wire. Multi-rated for wiring on industrial machines, automotive, truck, heavy equipment and appliances. Suitable for wet, dry or oily conditions. The smooth surface makes it ideal for pulling through loom or conduit. Temperature rating: 221°F (105°C). Nominal wall thickness: 30 mils. Made in U.S.A. Pkg: 1 Roll

Meets UL, CSA, MTW, TW, & AWM specifications.



MTW, TW: 600V 221°F (105°C) or for internal wiring of appliances.

AWM 1015: 600V oil resistant, 2500V peak electronic use.



AWM 1230: 221°F (105°C) 600V 60C oil and moisture resistant.

AWM 1345: 221°F (105°C) 600V 60C oil and moisture resistant.

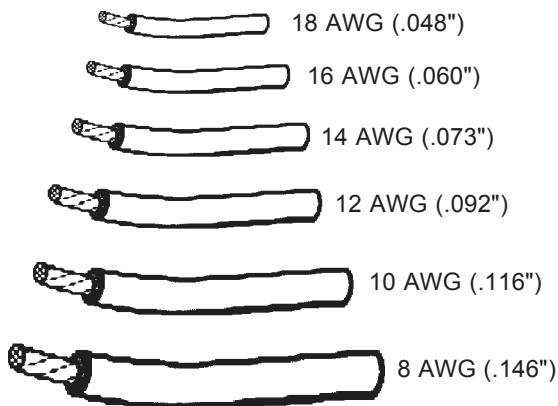
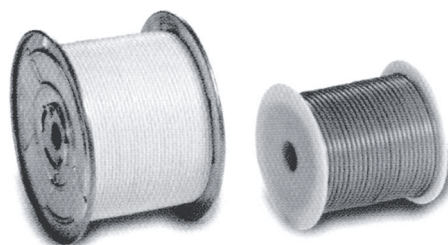

(ACTUAL SIZE)

Wire Gauge	Spool Size (ft.)	PART NUMBERS							
		Red	White	Black	Green	Yellow	Brown	Blue	
SMALL SPOOLS									
18	100'	26-200	26-201	26-202	26-206	26-203	26-205	26-204	
16	100'	26-207	26-208	26-209	26-213	26-210	26-212	26-211	
14	100'	26-214	26-215	26-216	26-220	26-217	26-219	26-218	
12	100'	26-221	26-222	26-223	26-227	26-224	26-226	26-225	
10	100'	26-228	26-229	26-230	26-234	26-231	26-233	26-232	
8	100'	26-235							
LARGE SPOOLS									
18	1000'	26-350	26-351	26-352	26-353	26-354	26-355	26-356	
16	1000'	26-357	26-358	26-359	26-360	26-361	26-362	26-363	
14	1000'	26-364	26-365	26-366	26-367	26-368	26-369	26-370	
12	500'	26-371	26-372	26-373	26-374	26-375	26-376	26-377	
10	500'	26-378	26-379	26-380					

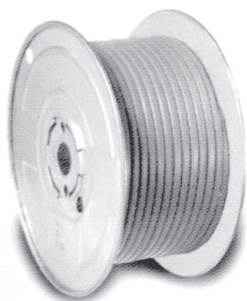

## Jacketed 2-Conductor Primary Wire



Two full gauge stranded copper (black and white) conductors covered with heavy duty gray plastic jacket. Recommended for trucks, trailers, buses, tractors, marine and general purpose wiring.

Part No.	Description	Pkg
26-240	16/2, 100 feet per roll	1 Roll
26-382	16/2, 1000 feet per roll	1 Roll
26-241	14/2, 100 feet per roll	1 Roll
26-384	14/2, 1000 feet per roll	1 Roll



# Stereo Speaker Wire



Two bonded 18 gauge wires for tape decks, radios, and speakers. Plastic insulated, stranded copper. Color-coded with polarity stripe. Made in U.S.A.

Part No.	Size	Pkg Qty
26-385	18/2, 100 ft/roll	1 Roll
26-386	18/2, 1000 ft/roll	1 Roll

# Wire Spool Rack

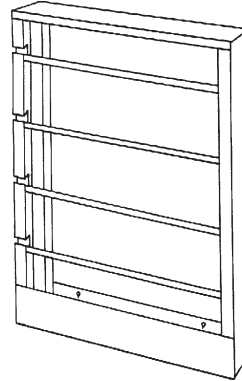

Stores a large supply of spooled products. Handy for abrasive rolls, baling wire and small hoses as well. Holds spools up to 10" diameter. 26W x 37H x 6D.  
**Part No. 98-WSR-4**

# Mechanic's Wire

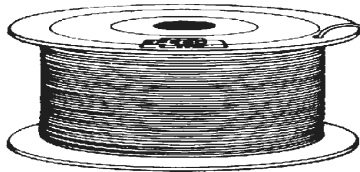

Annealed steel multipurpose wire. Can be used for hanging, bundling, baling and emergency repairs. Black finish.

Part No.	Gauge	Spool Size	Pkg Qty
1831	20 (.035")	5 lbs	1 Roll
1832	18 (.047")	5 lbs	1 Roll
1833	16 (.063")	5 lbs	1 Roll

# Heavy Duty Wire Spool Cart

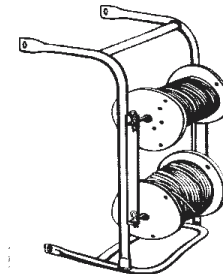
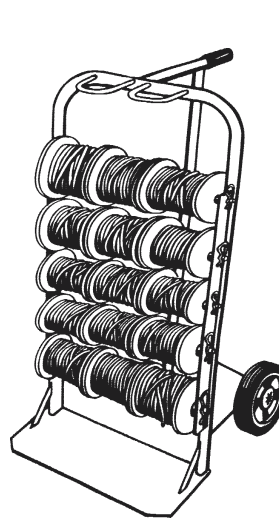

*Bolt-On Adapter  
(sold separately)*

**Wire Spool Cart** Designed to handle all of your wire needs right at the job-site. This durable cart is narrow enough to fit through any doorway. Accomodates up to fifteen 500 ft. spools of THHN or three 2,500 ft. reels of Romex. Works great for smaller spools of wire and hoses. Assembly of wheels and axle required. 23½W x 46H x 24D. **Part No. 29-436**

**Bolt-On Adapter** for the ability to carry even more wire without the expense of additional trucks. 18¾W x 33¼H x 18D. **Part No. 29-438**

# Wire Caddy

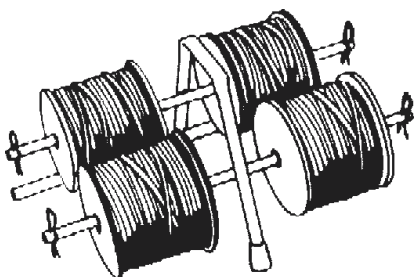

Compact and portable. Wire is easy to pull and control. A real time saver for small jobs. 21¼W x 11½D.  
**Part No. 29-442**

# Trailer Cable & Connectors

## Parallel Primary Wire

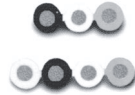
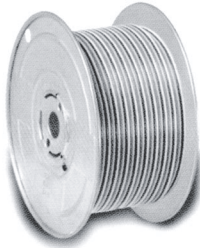

3 Conductor Green-Yellow-Brown  
4 Conductor Green-Yellow-Brown-White

Stranded copper, PVC insulated.

Part No.	Conductors	Size	Pkg
26-242	3	16 awg, 100'	1 Roll
26-243	3	14 awg, 100'	1 Roll
26-244	4	16 awg, 100'	1 Roll
26-245	4	14 awg, 100'	1 Roll

## Trailer Connectors



Socket



Plug with protector spring

Part No.	Description	Rating
03-299	6-Pole Socket	35 amp
03-295	7-Pole Socket	40 amp
03-296	6-Pole Plug w/Spring	35 amp
03-297	7-Pole Plug w/Spring	40 amp

*"How poor are they that have not patience! What wound did ever heal but by degrees."*

- William Shakespeare

## Trailer Cable

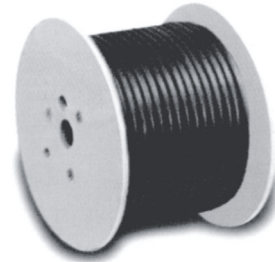

### PLASTIC OUTER JACKET

Part No.	Conductors	Gauge	Pkg
26-236	4	14	100'
26-237	6	14	100'
26-238	7	12 <sup>(6)</sup> , 10 <sup>(1)</sup>	100'
26-239	7	14	100'



### NEOPRENE OUTER JACKET

Part No.	Conductors	Gauge	Pkg
26-246	4	14	100'
26-247	6	14	100'
26-248	7	12 <sup>(6)</sup> , 10 <sup>(1)</sup>	100'

## Trailer Pin Connectors

Use for positive connections on trailer connectors and terminal blocks.

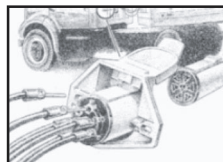

Trailer pins allow set screw to bite the pin instead of directly to fragile stranded wire. Nylon insulated with insulation grip.

Part No.	Wire Range	Color	Pin Diam.	Pkg Qty
02-186	22-18	Red	.030"	100
02-187	16-14	Blue	.030"	100
02-188	12-10	Yellow	.040"	50

# 3M Electrical Tape

## 3M™ Scotch™ Super 33+ Vinyl Electrical Tape



Super 33+ is a stickier, stretchier, highly conformable premium grade 7-mil thick tape that applies well at temperatures as low as -18°C/0°F and has an operating temperature range to 105°C/220°F. Flame retardant, hot and cold weather resistant. Resists UV rays, moisture, alkalis, acids and corrosion. Use as a primary insulation for wire cable splices up to 600V and for fixture and wire splices up to 1 kV. Meets ASTM, UL, HHI and CSA requirements.

Part No.	Size	Pkg
17-000	3/4" x 66 ft. roll	10 RL
17-000C	CASE of 100 rolls	1 CS

## 3M™ Scotch™ Super 88 Vinyl Electrical Tape



A heavy duty, 8.5-mil thick, flame retardant, weather resistant tape with superior cold weather handling features. Extra thickness provides added electrical properties, quicker insulation buildup and abrasion resistance. Remains conformable on cold days—even at -18°C/0°F and has an operating temperature range to 105°C/220°F. Resistant to UV rays, moisture, alkalis, acids and corrosion. Meets ASTM, UL, CSA and MIL specifications.

Part No.	Size	Pkg
17-008	3/4 X 66 ft. roll	10 RL
17-008C	CASE of 100 rolls	1 CS

## 3M™ Temflex™ 1700 Vinyl Electrical Tape



Temflex 1700 is 3M's economical, yet durable line of 7-mil thick tape. Performs well in a variety of indoor and outdoor installations. Flame retardant, UL listed and CSA certified for 80°C/176°F. Made in USA.

Part No.	Size	Pkg
17-019	3/4" x 60 ft. roll	10 RL
17-019C	CASE of 100 rolls	1 CS

## 3M™ Scotch™ 130C Linerless Rubber Splicing Tape



A highly conformable, high-voltage insulating tape formulated to provide excellent thermal dissipation of splice heat. Self-vulcanizes to a watertight bond. Rated for continuous operating service to 90°C and for short term overload service to 130°C. Insulates electrical connections thru 69kV. Stretch and wrap rubber tape under tension with a 50% overlap. Linerless feature provides faster, hassle-free installation. Add a layer of 3M electrical tape or friction tape to protect from abrasion and UV rays. Meets ASTM and HHI requirements.

Part No.	Size	Pkg
17-020	3/4" x 30 ft. roll	10 RL

## 3M™ Temflex™ 1755 Friction Tape



Temflex 1755 is a 15 mil thick, coated cloth tape used in electrical and mechanical applications. Made from high quality cotton fabric, coated with an electrical grade adhesive. Provides extra protection against friction and wear due to movement and vibration. Commonly used to protect rubber splicing tapes. Meets ASTM standards.

Part No.	Size	Pkg
17-020B	3/4" x 60 ft roll	10 RL

# 3M Electrical Tape

## 3M™ Scotch™ 27 Glass Cloth Electrical Tape

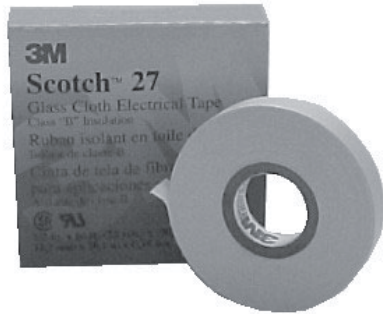

A 7-mil thick tape with thermosetting, pressure sensitive adhesive which performs at class B temperatures (130°C/266°F). 27 provides heat-stable insulation for hot-spot applications, such as furnace and oven controls, motor leads and switches. UL recognized component listing for 150°C. CSA accepted component listing for 130°C. Made in U.S.A.

Part No.	Size	Pkg
17-119	1/2" x 66 ft roll	10 RL

## 3M™ Scotch™ Electrical Moisture Sealant

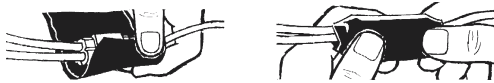

A tough, self-fusing, rubber based, insulating compound laminated to an all-weather grade vinyl (PVC) backing. Molds easily around difficult shapes and will insulate, moisture seal, and pad all connections up to 600V. Protects against elements and abrasion. Replaces common electrical tape for all season, all weather protection. 60 applications per roll.

Part No.	Size	Pkg Qty
17-014	2 1/2" x 10 ft.	1 RL

## GAMPAK® Color-Coded Electrical Tape



Pressure sensitive vinyl electrical tape used where color-coded wires are unavailable. Cold and weather resistant. Suitable for use at not more than 600 Volts as primary insulation. Flame retardant. UL recognized 119K at 80°C (176°F). CSA accepted. Roll size: 3/4" x 66 ft. Imported. (Not a 3M product)

Part No.	Color	Pkg
17-078	Red	10 RL
17-079	White	10 RL
17-080	Green	10 RL
17-085	Yellow	10 RL
17-087	Blue	10 RL
17-088	Orange	10 RL

17-096 .. Color-coded Electrical Tape Asst. .... 1 Kit  
Contains one of each color shown (bagged).

## Liquid Electrical Tape

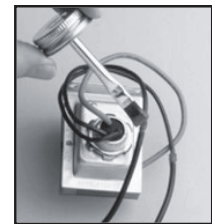

A dielectric coating that seals out moisture and prevents corrosion. Insulates, protects, will not crack, peel or harden. Remains flexible under extreme conditions. Acid and salt resistant. Stops terminal screws from vibrating loose. Applications: Terminal connections, damaged wire insulation and battery terminals on boats, trailers, autos, pumps, timers, pool filters and more. UL listed 746A Color: black. Made in U.S.A.

Part No.	Size	Pkg Qty
30-1002	4 oz. brush-can	12

# Nylon Cable Ties

Self-locking (nonreleasable) cable ties have bent-tips for easy insertion and fast installations. Secures wire bundles and harness components quickly. Molded from 6/6 nylon, use natural nylon for indoor use only, or use weather-resistant black nylon for indoor and outdoor use. Temperature range: -40° F to 185° F. Flame retardant, fungus inert. Resistant to solvents, alkalies and greases. UL recognized (file #E116841).



## NATURAL CABLE TIES

(Sold in full packages only.)

Part No.	Length	Width	Max Bundle Dia.	Tensile Strength	Pkg Qty
3150	4"	3/32"	3/4"	18 lbs	100
3151	6"	9/64"	1-1/4"	30 lbs	100
3152	8"	3/16"	2"	50 lbs	100
3153	11"	3/16"	3"	50 lbs	100
3154	14"	5/16"	4"	50 lbs	100
3155	15"	5/16"	4"	120 lbs	100
6-147	17"	5/16"	5"	120 lbs	100
6-148	28"	5/16"	8"	120 lbs	50



## BLACK UV CABLE TIES

(Sold in full packages only.)

Part No.	Length	Width	Max Bundle Dia.	Tensile Strength	Pkg Qty
3172	4"	3/32"	3/4"	18 lbs	100
3173	6"	9/64"	1-1/4"	30 lbs	100
3148	8"	3/16"	1-3/4"	50 lbs	100
3174	11"	3/16"	3"	50 lbs	100
3149	14"	3/16"	4"	50 lbs	100
3175	15"	5/16"	4"	120 lbs	100

### HEAVY DUTY LASHING TIES

3161A	24"	11/32"	6-1/4"	175 lbs	50
3162A	34"	11/32"	9-3/8"	175 lbs	50



## NATURAL MOUNTING HEAD CABLE TIES

Screw mountable, does away with mounting bases.  
(Sold in full packages only.)

Part No.	Length	Screw Size	Width	Max. Dia.	Tensile Strength	Pkg Qty
3158	8"	#10	3/16"	2"	50 lbs	100
3159	15"	1/4"	5/16"	4"	120 lbs	100

## CABLE TIE ACCESSORIES

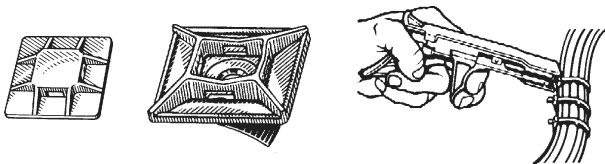

**3/4" SQUARE MOUNTING BASES** Pressure sensitive adhesive backing. For 18-40 lb. ties. Pkg: 50 **Part No. 3176**

**1" SQUARE MOUNTING BASES** Pressure sensitive adhesive backing and hole for screw mounting. For up to 50 lb. ties. Pkg: 50 **Part No. 3177**

**TENSIONING TOOL** Tightens cable ties to proper tension and trims the excess tie end. **Part No. 3160**

## CABLE TIE ASSORTMENTS



### BLACK UV NYLON CABLE TIE ASSORTMENT

6 SIZES, 4" THRU 15" LENGTHS, IN A LARGE STEEL DRAWER.  
**PART NO. 16-5306**

### NATURAL (WHITE) NYLON CABLE TIE ASSORTMENT

6 SIZES, 4" THRU 15" LENGTHS, IN A LARGE STEEL DRAWER.  
**PART NO. 16-5406**

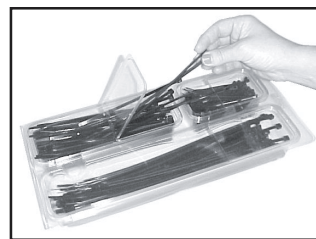

**NYLON CABLE TIE KITS** 3 SIZES, 4" (200), 7" (100) AND 11" (100) TIES IN A RECLOSABLE CLAMSHELL PACK.

NATURAL CABLE TIE KIT.....**PART NO. 29-432**  
BLACK UV CABLE TIE KIT.....**PART NO. 29-434**

# TY-RAP® Nylon Cable Ties

WITH STAINLESS STEEL LOCK

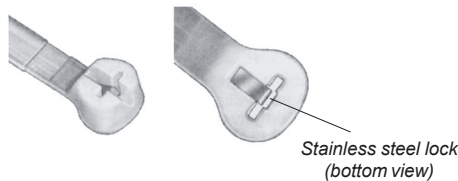

Natural 6/6 nylon cable ties with a stainless steel lock imbedded in the head for an extra-tight grip. Smooth, notchless design permits infinite adjustment. Exceeds MIL-S-23190. *Sold in full packages only.*

Part No.	Length	Width	Max Bundle Dia.	Tensile Strength	Pkg Qty
3178	3½"	3/32"	5/8"	18 lbs	100
3179	5½"	9/64"	1-1/4"	30 lbs	100
3180	8"	9/64"	2"	40 lbs	100
3181	11"	3/16"	3"	50 lbs	100
3182	13"	5/16"	3-1/2"	120 lbs	50
3183	30"	5/16"	9"	120 lbs	50

*UV resistant black available upon special request.*

## 3M Scotch-Code™ Wire Marker Tape Dispenser



Dispenser only. Holds ten rolls of special tape (*sold separately below.*) **Part No. 10-678**

### 3M™ Wire Marker Tape (White)

Part No.	Description	Pkg Qty
ASSORTED NUMBERS		
10-679	0-9 (10 rolls)	1 Pkg
INDIVIDUAL NUMBERS		
10-680	0	10 Rolls
10-681	1	10 Rolls
10-682	2	10 Rolls
10-683	3	10 Rolls
10-684	4	10 Rolls
10-685	5	10 Rolls
10-686	6	10 Rolls
10-687	7	10 Rolls
10-688	8	10 Rolls
10-689	9	10 Rolls

## Split Wire Loom

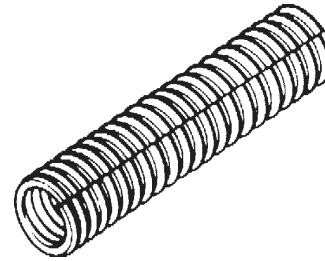

Use to cover wire, cable, hoses, etc. Split full length for ease of assembly, yet stays closed. Black nylon. Temp. range: -30°F to 300°F.

Part No.	Size	Pkg Qty
26-480	1/4 x 25'	1 Roll
26-249	3/8 x 25'	1 Roll
26-250	1/2 x 25'	1 Roll
26-251	3/4 x 25'	1 Roll

## Spiral Wire Loom

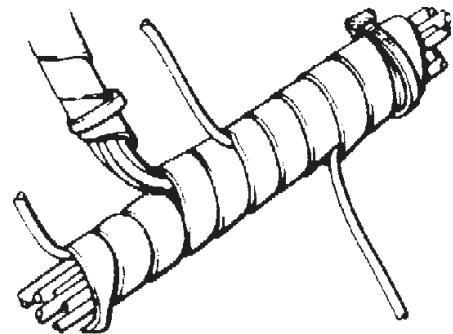

Wraps on like tape. Allows harness to be fed easily to different locations. Ideal for machine control circuits. Expandable and reusable. Natural white polyethylene.

Part Number	Size	Pkg Qty
26-430	1/4" x 100'	1 Roll
26-431	1/2" x 100'	1 Roll
26-432	3/4" x 50'	1 Roll

**Red Hot Deals!**

Check out our current specials  
and new items on our website at  
<http://www.mpi-online.com>



# Nylon Closed Clips

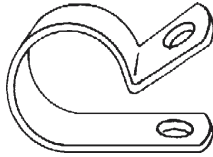

Nonconductive. Chemical and shock resistant nylon clip for wire loom, hoses or cables. Furnished open.

Part Number	Inside Diameter	Bolt Hole	Pkg Qty
<b>3/8" WIDE</b>			
1641	1/4	#8	25
1642	5/16	#8	25
1643	3/8	#8	25
1644	1/2	#8	25
1645	5/8	#10	25
1646	3/4	#10	25
1647	1"	#10	25

# Wire Loom Clips

Spring tension secures wiring, wire looms, cables and hoses to panels and frames. Pkg: 100 each

*Illustrations Actual Size.*

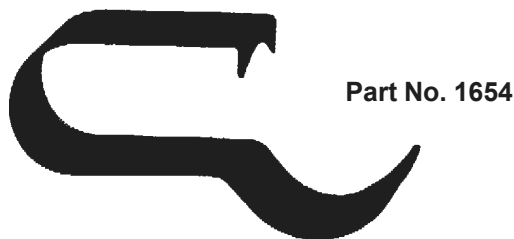

# Insulated Closed Clips



Plated steel with Vinyl coating

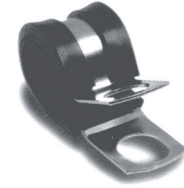

Aluminum with neoprene rubber cushion

Used to fasten wire loom, hose, tubing and cable. Furnished open. Temperature and oil resistant.

Size Closed I.D.	STEEL	ALUMINUM	Pkg Qty
	w/Vinyl Dipped	w/Neoprene Cushion	
<b>1/2" WIDE, 1/4" BOLT HOLE</b>			
1/4	1601	02-440	25
5/16	1602	02-441	25
3/8	1603	02-442	25
1/2	1604	02-443	25
5/8	1605	02-444	25
3/4	1606	02-445	25
7/8	1607	02-446	25
1"	1608	02-447	25
<b>3/4" WIDE, 3/8" BOLT HOLE</b>			
1/4	1609	-	25
5/16	1610	-	25
3/8	1611	-	25
1/2	1612	-	25
5/8	1613	-	25
3/4	1614	-	25
7/8	1615	-	25
1"	1616	-	25
1-1/4	1617	-	25
1-1/2	1618	-	25

# Adhesive Backed Nylon Tubing Clamps

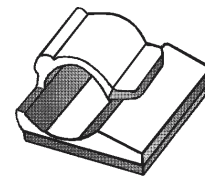

Secures wiring, hose and tubing to most surfaces. Locks securely, opens easily. Use at temperatures up to 180°F.

Part No.	Tubing Diameter (O.D.)	Pkg Qty
1648	5/32" to 1/4"	25
1649	5/16" to 1/2"	25
1650	9/16" to 3/4"	25



# Circuit Alert™

## Non-Contact Voltage Locator

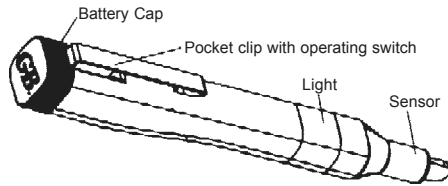

**NO CONTACT WITH CONDUCTOR REQUIRED**

**ALERTS USERS WITH AUDIBLE "CHIRP"  
& FLASHING LIGHT**

Circuit Alert is an inductive voltage tester that senses 50-600V AC voltage through the wire insulation! Safely locate defective grounds, energized circuits, induced voltage. In presence of AC voltage, a light in handle continuously flashes cherry red along with an loud audible "chirp". Has operating switch with battery test. No skill required for operation. 2 LR44 batteries included. Imported. **Part No. 29-429**

# LCD Digital Multimeter

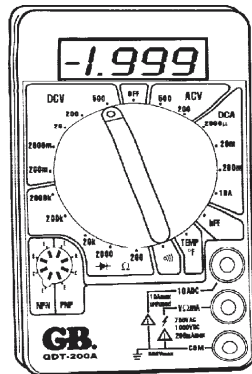

### 7 FUNCTION, 19 RANGE • LCD READOUT

Check AC/DC voltage, DC current (amps), resistance (ohms), diodes, audible continuity, temperature and transistors. Use to test batteries, fuses, extension cords, receptacles, automotive wiring, appliances, switches, diodes, transistors, electronic equipment and lighting fixtures. 9V battery included. Imported. **Part No. 29-420**

# The AC Sensor

## Non-Contact Voltage Sensor

**DETECTS AC CURRENT  
WITHOUT METALLIC CONTACT**

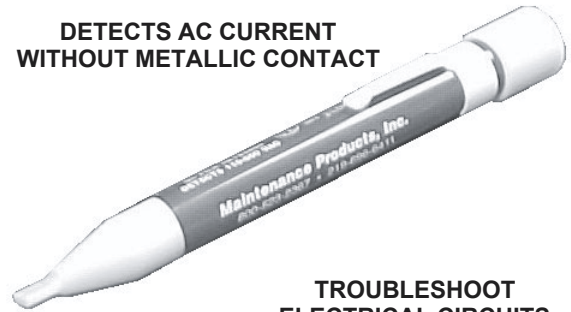

**TROUBLESHOOT  
ELECTRICAL CIRCUITS**

**The choice of OSHA!** Determines the presence or absence of AC voltage in insulated wires, wall receptacles, fuses, junction boxes, switches, and any other voltage carrying electrical system. No contact is required for operation. Simply touch the plastic probe tip to a connection point or move it along an insulated wire. If AC voltage is present, the probe tip will glow bright red. The illumination will stop at a break in the circuit or wire. *Selected by OSHA as the only instrument of its type for use by OSHA compliance officers to identify and cite electrical hazards of 50 volts or more.* Locates voltage of 110-600 AC. UL listed 39F5. Uses 2 AAA batteries (*included*). Limited warranty. Made in U.S.A. **Part No. 21-367**

# Tester Probes

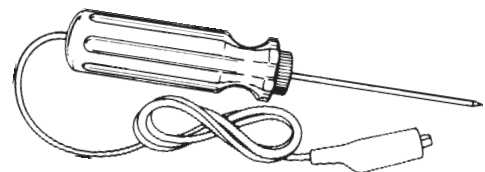

**CONTINUITY TESTER NOT FOR LIVE CIRCUITS.** Checks circuit continuity with power OFF. Bulb in handle glows when circuit is complete. Detects shorts and broken circuits in wires and switches. Long 36" test lead. Uses size AAA battery (*not included*). Made in U.S.A. **Part No. 29-418**

**LOW-VOLTAGE TESTER FOR 6 - 24V LIVE CIRCUITS (AC/DC) WITH POWER ON.** Bulb in handle glows when circuit is complete. Easily find broken wires in circuit as bulb will stop glowing at dead point. Detects shorts in live circuits, wires, relays, radios, fuses, bulbs, connectors, coils, switches, etc. Long 36" test lead. Made in U.S.A. **Part No. 29-416**



# Compact Fluorescent Work Lights

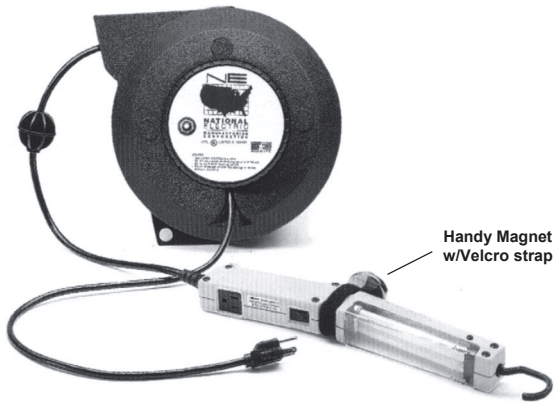

## Rough Service Angle Light On Heavy Duty Reel - 13 Watt

- Doubles as an extension cord — 110 volt power outlet with 10 amp circuit breaker
- On/off switch built into handle.
- Handy magnet with Velcro® strap
- 50 ft. of 16/3 cord - oil and water resistant.
- 60 watts of light from a 13-watt bulb (included).
- Replacement parts available.

**Part No. 17-178**

*(Replacement bulb no. 17-174)*

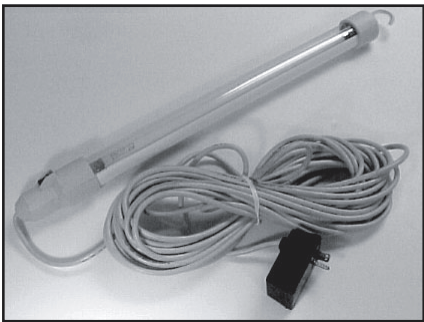

## Compact Fluorescent Drop Light

- Runs cooler than incandescents.
- On/off switch built into handle.
- 360°swivel hook, nonglare reflector
- 50 ft. of 18/3 cord - oil and water resistant.
- 15-watt bulb (included).

**Part No. 17-167**

*(Replacement bulb no. 17-168)*

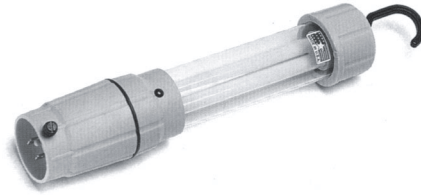

## The Light Rover - 13 Watt

- Any extension cord instantly converts to a 13 watt fluorescent light when plugged into this light.
- Compact design installs in seconds.
- Includes a "no-pull-out" cord lock.
- 60 watts of light from a 13-watt bulb (included).

**Part No. 17-176**

*(Replacement bulb no. 17-174)*

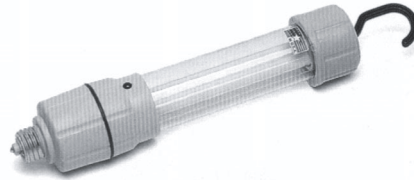

## The Convertible - 13 Watt

- Replace any hot, dangerous incandescent trouble light with a cool running fluorescent light.
- Use with all incandescents, including cord reels.
- 60 watts of light from a 13-watt bulb (included).

**Part No. 17-175**

*(Replacement bulb no. 17-174)*



## Compact Fluorescent Drop Light

- Runs cooler than incandescents.
- On/off switch built into handle.
- 360°swivel hook, nonglare reflector
- 25 ft. of 18/3 cord - oil and water resistant.
- 60 watts of light from a 13-watt bulb (included).

**Part No. 17-173**

*(Replacement bulb no. 17-174)*

# Work Lights & Light Bulbs

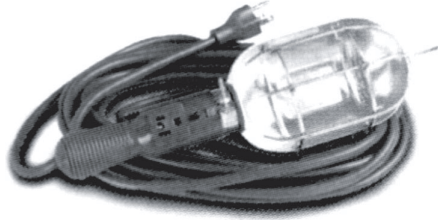

## Hand Lamp

Standard "drop light" with plated steel guard, on-off switch, 16/3 type SJT cord and 3-hole outlet. 125 volt. UL and OSHA approved. Bulb not included.

Cord Length	Part Number	Pkg Qty
25'	17-015	1
50'	17-016	1

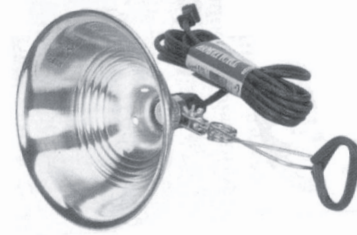

## Clamp Light with Reflector

With swivel adjustment. 125 volt. 18/2 cord is 6 ft long. UL approved. Bulb not included.

Cord Length	Part Number	Pkg Qty
6'	17-181	1

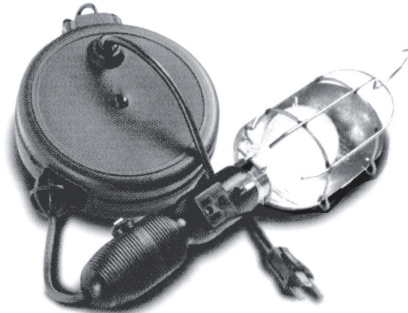

## Power Reel Lamp

Heavy duty reel with plated steel guard, on-off switch, 16/3 type SJT cord and 3-hole outlet. 125 volt. UL and OSHA approved. Ceiling or wall mount. Bulb not included.

Cord Length	Part Number	Pkg Qty
25'	17-021	1



## Quartz Halogen Light Bulbs

Whiter, more vibrant light than incandescent bulbs. RSC base/clear. 120 volts.

Part No.	Watts	Volts	Pkg Qty
17-171	300	120	20
17-172	500	120	20



## 13 Watt Twin Tube Compact Fluorescent Bulbs

Cool white bulb fits most 110 volt stubby work lights. Average life: 10,000 hours. GX23 base. Made in U.S.A.

Part No.	Trade Number	Pkg Qty
17-174	...PR13, F13TT/841, CFT13W/GE23/41	10

## Shop Light Repair Parts

### Metal Guard

Swing open design.

Part No. 17-092

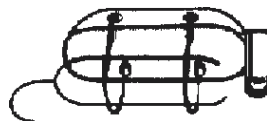

### Plastic Handle

Switch and tool tap included. Use with 18 or 16 gauge wire.

Part No. 17-093



## 15 Watt Fluorescent Bulbs

Cool white bulb for most 15 watt, 2-pin work lights. 110 volts. Made in U.S.A.

Part No.	Trade Number	Pkg Qty
17-168	..... F15T8	10



# Rough Service Bulbs

Features special heavy duty filament design and shorter stem to absorb greater shock and vibration than ordinary bulbs. Frosted bulb. Corrosion resistant medium brass base. Long life. Vibration service - designed exclusively for the automotive industry.

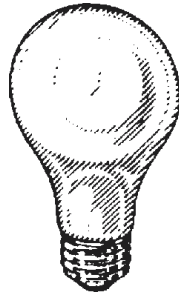

Part No.	Watts	Pkg
<b>75 WATT, 130 VOLT</b>		
26-183 .....	75 Watt Bulbs .....	6 ea
26-183PK .....	Pack of 24 .....	1 Pkg
26-183C .....	Case of 120 .....	1 Case
<b>100 WATT, 130 VOLT</b>		
26-184 .....	100 Watt Bulbs .....	6 ea
26-184PK .....	Pack of 24 .....	1 Pkg
26-184C .....	Case of 120 .....	1 Case
<b>50 WATT, 12 VOLT (AUTOMOTIVE)</b>		
26-185 .....	50 Watt Bulbs .....	6 ea

# Tuff-Skin Coated Rough Service Bulbs

LONG-LIFE  
5000 HOUR BULB

The safest, sturdiest bulb ever developed. Reinforced filament support for durability. Shatter-resistant coating prevents fragmentation if broken. Protects personnel and equipment from shattered glass caused by impact, dropping, unusual stress, thermal shock and contact with liquids. UL listed & OSHA approved. Frosted bulb with corrosion resistant medium brass base.



Part No.	Watts	Volts	Pkg
26-186 .....	75W .....	130V .....	6 ea
26-188 .....	100W .....	130V .....	6 ea

# Heavy Duty Extension Cords

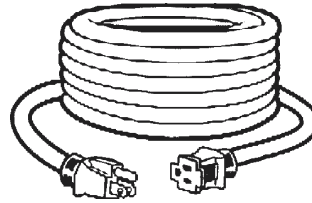

Single outlet. Extra flexible for all-weather use. Oil resistant. Type SJT round cord. OSHA approved.

Part No.	Cord	Length	Rating	Pkg
17-023 .....	14/3 .....	50 ft. ....	15A-125V .....	1
17-024 .....	14/3 .....	100 ft. ....	15A-125V .....	1
17-025 .....	12/3 .....	50 ft. ....	15A-125V .....	1
17-026 .....	12/3 .....	100 ft. ....	15A-125V .....	1

## 30 Ft. Heavy Duty Power Reel Cord

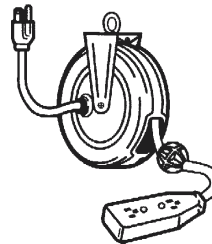

16/3 Type SJT round cord. Four grounded outlets. Ceiling or wall mount. UL and OSHA approved. 15A-125V. **Part No. 17-027**

# Power Cord Connectors

## Rubber Cord Connectors

All Rubber Cover. Armored Grip U-Blade Parallel Grounding. 15 amps -125 volts. 3-wire grounding type. Pkg: 10.

**Part No. 02-308**



## Rubber Caps

All Rubber Cover. Armored Grip U-Slot Grounding. 15 amps - 125 volts. 3-wire grounding type. Pkg: 10.

**Part No. 02-309**



## Heavy Duty Cord Connectors

Unbreakable Vinyl. U-Blade Parallel Grounding. 15 amps - 125 volts. 3-wire grounding type. Pkg: 10.

**Part No. 02-311**



## Heavy Duty Caps

Unbreakable Vinyl construction. U-Slot Grounding. 15 amps - 125 volts. 3-wire grounding type. Pkg: 10.

**Part No. 02-312**

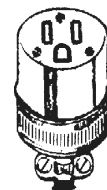

# Wiring Tools

## Multi-Purpose Crimping Tool

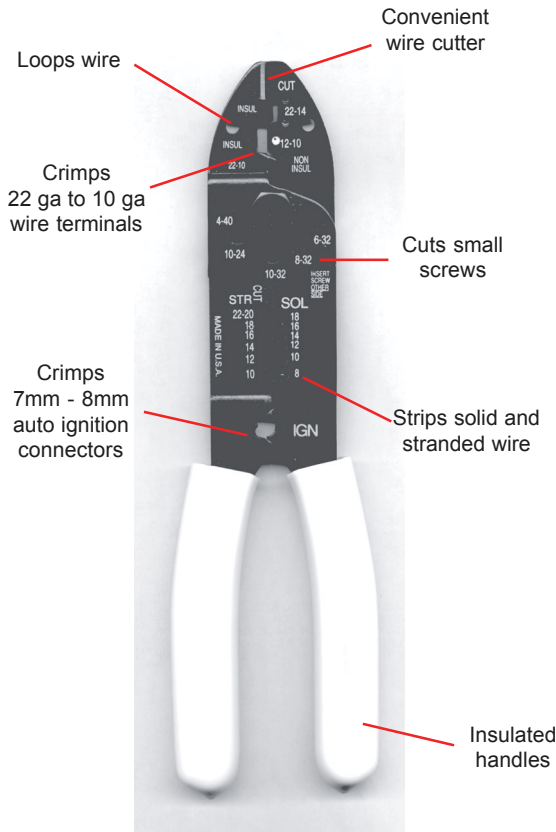

Our most popular crimper, cutter, and wire stripper. Long, insulated handles for more leverage. Length is 8½". Conditional warranty (against defects, not normal wear). Made in U.S.A. **Part No. 23-305**

**CHAN NEL LOCK**

## Crimping Tool



A favorite among electricians and mechanics. Securely crimps insulated and non-insulated terminals with ease. Streamlined head permits work in confined space. Crimps 10 to 22 AWG. Wire cutters in nose cuts solid or stranded electrical wires. Channellock blue® insulated handles. Length is 9¾" for powerful leverage. Lifetime warranty. Made in U.S.A.

**Part No. CN-909**

Also see "Battery Terminal Crimpers & Tools"

**CHAN NEL LOCK**

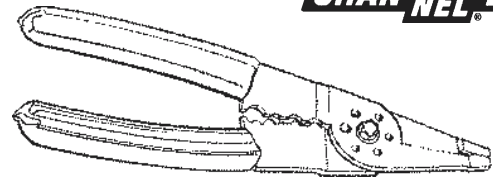

## Long-Nose Crimping Tool

Narrow, serrated plier nose pulls, loops and bends wire ends. Pliers and cutters located in front to reach into tight areas. Crimps all terminals from 10 to 22 gauge. Cuts bolts. Insulated handles. Lifetime guarantee. **Part No. CN-908G**

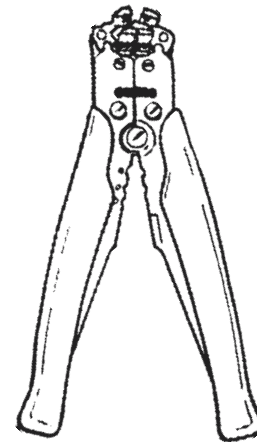

## The Easy Stripper

*(Automatic Wire Stripper)*

The fastest way to strip wire. Automatically self-adjusts from 12 to 26 gauge wire, solid or stranded. Heavy duty design. Also has a built-in wire cutter and crimper. 90-day warranty (against defects, not normal wear). Imported. **Part No. 23-306**



# Heavy Wall Heat Shrinkable Tubing

## With Adhesive Melt Liner

Heavy Wall Heat Shrink Tubing has a 3:1 shrink ratio. Application of heat causes an adhesive liner to melt and form intimate contact with all underlying surfaces and voids, yielding a watertight seal suitable for underground applications. Recommended for protecting and insulating splices and terminations. Perfect battery connection insulation. Meets U.L. 486D requirements. Pkg: 6 each.



Approx. I.D.	Wire Range	Color	Max. Wall Thickness <sup>1</sup>	Inside Dia. (in.)		12" Length Part No.	1½" Length Part No.
				Exp. <sup>2</sup>	Rec.		
5/16	18-14	Black	.060	.300	.100	02-363	-
5/16	18-14	Red	.060	.300	.100	02-364	-
7/16	14-6	Black	.060	.400	.150	02-313	-
7/16	14-6	Red	.060	.400	.150	02-365	-
3/4	8-1	Black	.090	.750	.220	02-314	02-314A
3/4	8-1	Red	.090	.750	.220	02-315	02-315A
1-1/8	2-4/0	Black	.120	1.100	.375	02-316	02-316A
1-1/8	2-4/0	Red	.120	1.100	.375	02-317	02-317A
1-1/2	4/0-400	Black	.140	1.500	.500	02-366	-
2"	500-1000	Black	.155	2.000	.750	02-367	-

# Medium-Wall Heat Shrinkable Tubing

## With Adhesive Melt Liner

Thick but flexible medium wall with meltable adhesive liner provides totally waterproof electrical connections. Superior resistance to abrasion, salt, water, and corrosive materials. 3:1 shrink ratio. Flame resistant. For electronics, plant maintenance, vehicle, boat repair, & O.E.M. applications. Wall thickness<sup>1</sup> - 1/16.

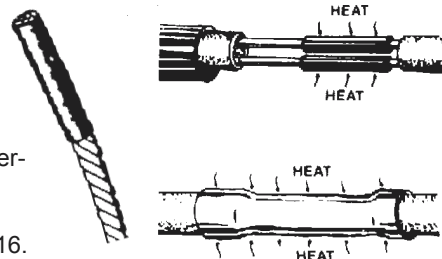

Dia.	Wire Range	Color	Inside Dia. (in.)		6" Length Part No.	Pkg Qty	48" Length Part No.	Pkg Qty
			Exp. <sup>2</sup>	Rec.				
1/8	to 18	Black	.125	.0394	17-046	10	17-061	1
3/16	20-12	Black	.187	.0591	17-047	10	17-062	1
1/4	18-10	Black	.250	.0787	17-048	10	17-063	1
3/8	16-6	Black	.375	.1181	17-049	10	17-064	1
1/2	8-4	Black	.500	.1614	17-050	10	17-065	1
3/4	4-3/0	Black	.750	.3110	17-051	5	17-066	1
3/4	4-3/0	Red	.750	.3110	17-051R	5	17-066R	1
1"	2-4/0	Black	1.000	.3937	17-052	5	17-067	1
1"	2-4/0	Red	1.000	.3937	17-052R	5	17-067R	1

<sup>1</sup> Maximum wall thickness before shrinking.

<sup>2</sup> Tubing is supplied in "Expanded" inside diameter (I.D.) dimensions.

# Electric Heat Guns

## QuickHeat 1® Commercial Grade Electric Heat Gun

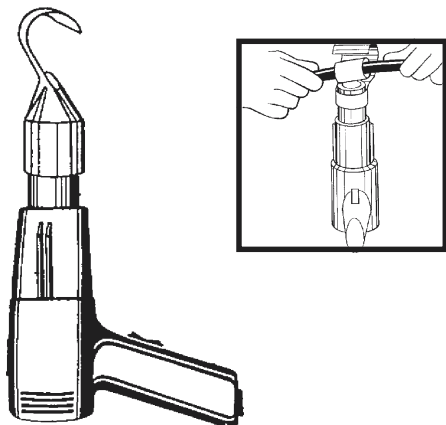

Apply heat shrink tubing quickly and without the danger of fire. Comes with medium size heat shrink deflector. For heat-shrink tubing under 1" diameter. Thaws frozen pipes and locks, form or bend plastics, removes ceramic tile, loosens rusted nuts, and solders. Durable high impact housing. Dual heat settings: +750°F and +1000°F. 120 volts, 1200 watts, UL & CSA approved.  
**Part No. 23-311**

## QuickHeat 2® Industrial Grade Electric Heat Gun

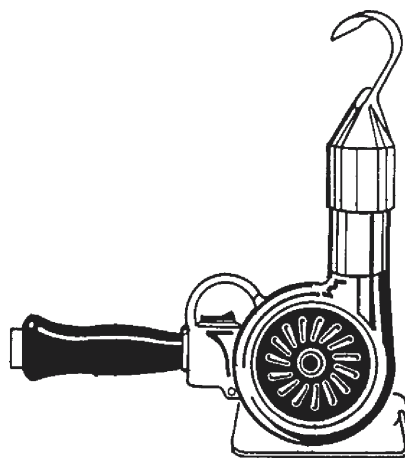

Heavy duty metal housing. Includes large shrink tube deflector for heat-shrink tubing up to 1½" diameter. +750°F - adjustable air flow. All metal housing with adjustable stand. 120 volts, 1680 watts, UL approved.  
**Part No. 23-312**

## Heat Gun Accessories



**MEDIUM WALL SHRINK TUBING ASSORTMENT**  
 6 SIZES, 3/16" O.D. THRU 3/4" O.D. BLACK, & 3/4" O.D. RED, 16" LENGTHS, IN A LARGE DRAWER.  
**PART NO. 16-4706**

**HEAVY WALL SHRINK TUBING ASSORTMENT**  
 (not pictured)  
 6 SIZES, .300" O.D. THRU 2" O.D. BLACK TUBING, 12" LENGTHS, IN A LARGE DRAWER.  
**PART NO. 16-5206**

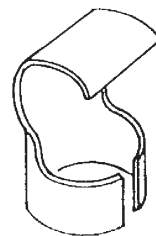

**MEDIUM DEFLECTOR** for QuickHeat 1 only, designed for shrink tubing sizes up to 1". **Part No. 23-313**

**LARGE DEFLECTOR** for QuickHeat 1 & QuickHeat 2, designed for shrink tubing sizes to 1½". **Part No. 23-314**

**ACCESSORY KIT** for QuickHeat 1 only. Includes 2½" wide paint scraper, pin point nozzle, flat nose nozzle, 4" wide nozzle to protect glass. **Part No. 23-315**



# Solder & Flux

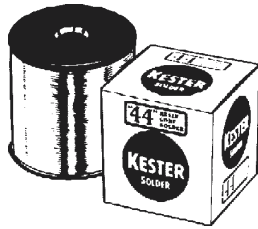

## Kester 40/60 Resin Core Solder

For most electrical applications. 40% Tin, 60% Lead. Melting point: 460°F. Diameter: .093" (3/32"). 1 lb. spools. **Part No. 21-303**

## Kester 40/60 Acid Core Solder

For radiators, plumbing, and sheet metal repairs. 40% Tin, 60% Lead. Melting point: 461°F. Diameter: .093" (3/32"). 1 lb. spools. **Part No. 21-304**

## Kester 50/50 Solid Wire Solder

Used extensively in plumbing work and with crafts. 50% Tin, 50% Lead. Melting point: 421°F. Diameter: .125" (1/8"). 1 lb. spools. **Part No. 21-305**

## Kester "Economy Series" Solder

A commercial grade designed for the occasional solder user. 1/8" diameter, 1 lb. spools.

- 21-306 ..... Resin Core Solder
- 21-307 ..... Acid Core Solder
- 21-308 ..... Solid Wire Solder



## Kestor "Kwik-Draw" 60/40 Resin Core Solder

A strong, low-temperature solder. Use for all electrical applications. 60% Tin, 40% Lead. Melting point: 360°F. Diameter: .050" (3/64"). Size: 1.3 oz. Pkg: 6 tubes. **Part No. 21-309**

## Liquid Soldering Flux

(Tinnors Fluid) Use to clean solder joints. 4 oz. bottle. **Part No. 21-324**



## Acid Soldering Paste Flux

Use with solid wire solder for lead-free plumbing (non-electrical) repairs.

**Part No. 21-325**



# Flashlights

## Aluminum Flashlights



These rugged flashlights adjusts from flood to spot by turning the head. Waterproof and shock resistant. Nonslip rubber ring on head. Made in U.S.A.

- 17-089 2 D-cell flashlight
- 17-090 3 D-cell flashlight
- 17-091 2 AA-cell pocketlight

## WorkSAFE™ Hazardous Location Flashlights

- DIVISION 1 CERTIFIED\*
- 3-WAY SWITCH
- WATERPROOF DESIGN

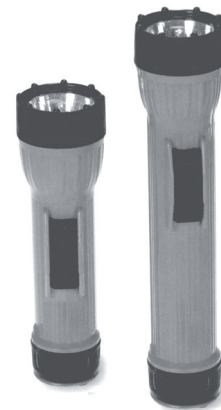

Designed specifically for use in *Division 1 hazardous locations*. \* Each flashlight is individually tested and certified. The waterproof design makes them ideal for wet conditions. Features waterproof 3-way switch with on and off position, and a middle position with a button which can be pressed to provide intermittent flashing. UL listed class I groups C, D, class II group G, and class III. MSHA approved, CSA certified. Meets ASTM type II. Made in U.S.A. Color is orange/black.

- 17-094 2D-cell WorkSAFE™ Flashlight Pkg: 12 each
- 17-095 3D-cell WorkSAFE™ Flashlight Pkg: 12 each

*\*Division 1 Hazardous Locations: Where ignitable concentrations of flammable gases, vapors or liquids can exist all of the time or some of the time under normal operating conditions.*



# Flashlights and Bulbs



## 2-D Cell Light Industrial Flashlight

Light duty flashlight. Top loading and constructed of lightweight and durable polypropylene. Ideal for auto and other light duty uses. Made in U.S.A. Use Repl. bulb. #17-037 (PR2). **Part No. 17-086** Pkg: 24 each



## 2-D Cell Light Duty Industrial Flashlight W/Magnet

Top loading and constructed of lightweight and durable polypropylene. Break resistant polyethylene construction. Made in U.S.A. Repl. bulb no. 17-037 (PR2). **Part No. 17-028** Pkg: 24 each



## 2-D Cell Heavy Duty Industrial Flashlight with Continuity Tester

Continuity tester and flashlight in one! Crush resistant thermoplastic polymer case with unbreakable Tuflexx® lens. 250,000 cycle switch with switch guard. Each continuity tester comes with 36" leads. Made in U.S.A. Repl. bulb no. 17-037 (PR2). **Part No. 17-029** Pkg: 12 each



## RAYOVAC® WORKHORSE® Flashlights

Rugged housing, switch and bright Krypton bulb.  
2 D-Cell repl. bulb: 17-115 (K2), 3 D-Cell repl. bulb: 17-116 (K3).  
**17-109** 2 D-Cell WorkHorse® Pkg: 12 each  
**17-108** 3 D-Cell WorkHorse® Pkg: 6 each

## 6V Light Duty Industrial Lanterns



This lantern is not only waterproof, it floats! Provides extra-long power and long beam range. Made in U.S.A. Repl. bulb no. 17-042 (PR13). Uses 6 volt square battery with spring terminals (battery not included). **Part No. 17-031** Pkg: 6 each

## Flashlight Bulbs



Part No.	Industry No.	Application	Pkg Qty
STANDARD FLANGE BASE			
17-037	PR2	2, D Cell	10
17-038	PR3	3, D Cell	10
17-039	PR4	2, D Cell	10
17-040	PR6	2, D Cell	10
17-041	PR12	5, D Cell	10
17-042	PR13	6V Cell	10
STANDARD SCREW BASE			
17-043	14	2, D Cell	10
17-044	222	2, AA Cell	10
KRYPTON FLANGE BASE (2 per card)			
17-114	K1	2, C Cell	1 Pkg
17-115	K2	2, D Cell	1 Pkg
17-116	K3	3, D Cell	1 Pkg
17-117	K4	2, AA Cell	1 Pkg
17-118	K13	6V Cell	1 Pkg

*Krypton bulbs may be substituted for standard flange base flashlight bulbs.*



# Flashlight & Lantern Batteries



## Heavy Duty Batteries

Outperforms general purpose batteries.

Description	Part No.	Pkg
D Cell, 1-½ Volt Manganese .....	13-502 .....	24 each
Case of 72 .....	13-502C .....	1 Case
6 Volt Zinc, Lantern w/spring terminals .....	13-504 .....	12 each



## Bright Star Alkaline Batteries

99.999% Mercury Free. Maximum economy and performance.

Made in U.S.A.



Description	Part No.	Pkg
AAA Cell, 1-½ Volt (4 per sleeve) .....	13-506 .....	24 each
Case of 72 .....	13-506C .....	1 Case
AA Cell, 1-½ Volt (4 per sleeve) .....	13-507 .....	24 each
Case of 72 .....	13-507C .....	1 Case
C Cell, 1-½ Volt .....	13-508 .....	24 each
Case of 72 .....	13-508C .....	1 Case
D Cell, 1-½ Volt .....	13-509 .....	24 each
Case of 72 .....	13-509C .....	1 Case
9 Volt Transistor .....	13-510 .....	12 each

## DURACELL® Alkaline Batteries

The "Copper-Top" battery. 99.9% Mercury Free.

Unique battery tester included. Made in U.S.A.

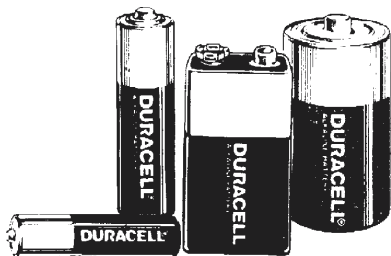

Description	Part No.	Pkg
AAA Cell, 1-½ Volt, (4 per card) .....	13-511 .....	24 each
Case of 72 .....	13-511C .....	1 Case
AA Cell, 1-½ Volt, (4 per card) .....	13-512 .....	24 each
Case of 72 .....	13-512C .....	1 Case
C Cell, 1-½ Volt, (4 per card) .....	13-513 .....	24 each
Case of 72 .....	13-513C .....	1 Case
D Cell, 1-½ Volt, (4 per card) .....	13-514 .....	24 each
Case of 72 .....	13-514C .....	1 Case
9 Volt Alkaline, Transistor .....	13-515 .....	24 each
6 Volt Alkaline, Lantern w/spring terminals* .....	13-516 .....	12 each

\*Tester not included with #13-516. ©DURACELL is a registered trademark of Duracell Inc.

# Fusion™ Solder System

**Just Add Heat!**

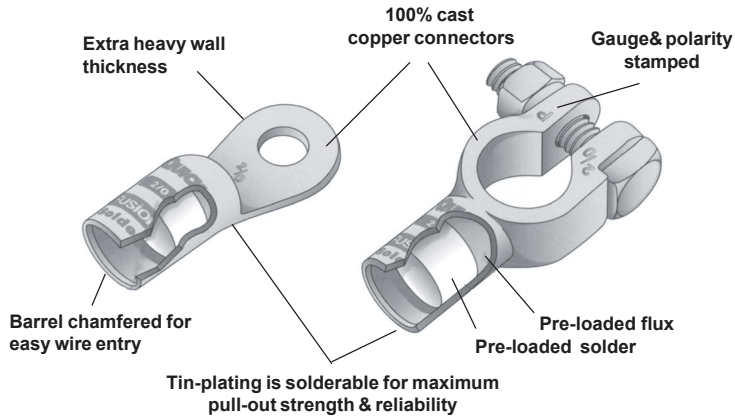

## CAST COPPER CONNECTORS With Pre-loaded Solder And Flux



The best connection for long term reliability on critical applications, especially in presence of corrosion and vibration. Fusion™ connectors come ready-to-use. The correctly engineered flux and solder is precisely pre-measured and loaded in a solderable tin-plated copper connector. Fusion™ connectors provide more consistent quality than any other solder method - including solder slugs. The Fusion™ system is complete, offering everything needed to build or repair cables. Easy for inexperienced users., saves time and money. Made in U.S.A.

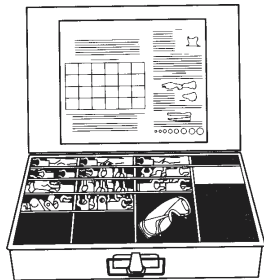

### FUSION™ CONNECTOR ASSORTMENT

1 & 2 GA., 1/0 GA., AND 2/0 GA. POSITIVE AND NEGATIVE TOP POST CLAMPS, LUGS, 3/4" ID SHRINK TUBING (RED AND BLACK), BATTERY BOLTS, SHOULDER NUTS, SAFETY GLASSES, SOLDER FLUX, CLEANING BRUSH AND LARGE STEEL DRAWER. **PART NO. 16-5212**



Cable Gauge	Color	Top-Post Clamps		Heavy Wall Lugs
		Negative	Positive	
4	Gray	02-411	02-412	02-423
1 & 2	Pink	02-413	02-414	02-424
1/0	Black	02-415	02-416	02-425
2/0	Orange	02-417	02-418	02-426
3/0	Purple	02-419	02-420	02-427
4/0	Yellow	02-421	02-422	02-428

**All Pkg: 5 each**

## FAST, QUALITY RESULTS EVERY TIME!

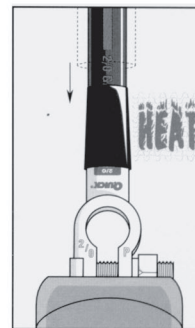
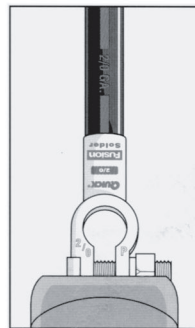
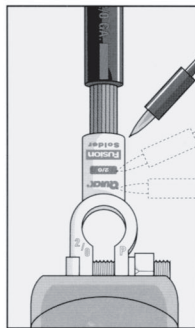
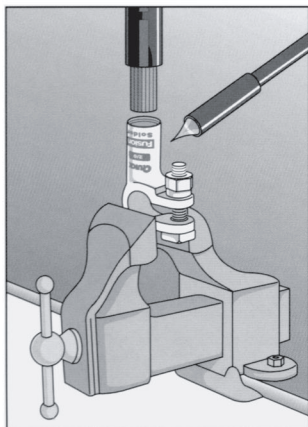

Strip back new battery cable 7/8" and slip heat shrink tubing over cable. Secure connector in vise, apply heat, insert cable, allow to cool, install heat shrink tubing. *Note: Clean and prepare old existing cables with liquid flux and a small wire brush before installation. Cleaning not required for new cables.*



# "CRIMP-TITE" Heavy Duty Battery Terminals

100% Cast Copper Alloy • 100% Tin Plated  
100% Machine Finished • Can be crimped or soldered  
Die marked for any crimping tool

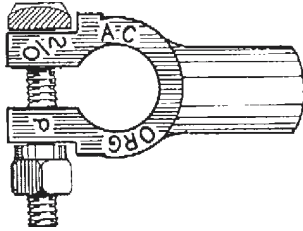

## Single Barrel Post Type

Part No.	Cable Size	Post	Pkg
4513	6 ga	Universal	5
4514	4 ga	Universal	5
26-277	4 ga	Positive	5
26-278	4 ga	Negative	5
4515	1 & 2 ga	Positive	5
4516	1 & 2 ga	Negative	5
4517	1/0	Positive	5
4518	1/0	Negative	5
4519	2/0	Positive	5
4520	2/0	Negative	5
26-190	3/0	Positive	5
26-191	3/0	Negative	5
26-192	4/0	Positive	5
26-193	4/0	Negative	5

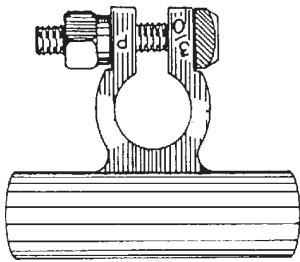

## Double Barrel Post Type (Flag Clamp)

Part No.	Cable Size	Post	Pkg
26-279	1/0	Positive	5
26-280	1/0	Negative	5
26-194	2/0	Positive	5
26-195	2/0	Negative	5
26-196	3/0	Positive	5
26-197	3/0	Negative	5
26-281	4/0	Positive	5
26-282	4/0	Negative	5

# "RETRO-FIT" Battery Terminals

Side or Top Mount • 100% Cast Copper Alloy  
100% Tin Plated • Can be crimped or soldered  
Use with truck, auto, marine, & heavy equipment  
Stack-able for top mount battery applications  
Die marked for any crimping tool

*Does not include Hold-Down Nuts or Side-Mount Bolts*

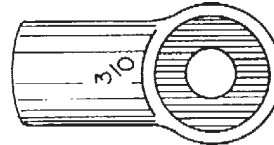

## Single Barrel Retrofit

Part No.	Cable Size	Pkg
26-272	6 & 4 ga	5
26-273	1 & 2 ga	5
26-252	1/0	5
26-253	2/0	5
26-254	3/0	5
26-274	4/0	5

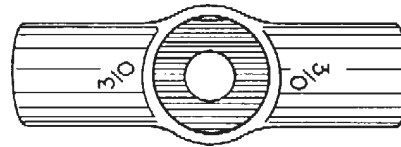

## Double Barrel Retrofit

Part No.	Cable Size	Pkg
26-255	1/0	5
26-256	2/0	5
26-257	3/0	5
26-276	4/0	5



## 3/8-16 Stud-Top Battery Nuts

Stainless steel closed cap nut for stud-top batteries.  
Fits both positive and negative posts. Corrosion resistant.  
Pkg: 10 each. **Part No. 26-258**



# Compression Battery Terminals & Lugs

Great for in-the-field repairs. Made from 100% cast copper. Double tin plated and color coded. Complete with compression nuts, battery bolts, and shoulder nuts.

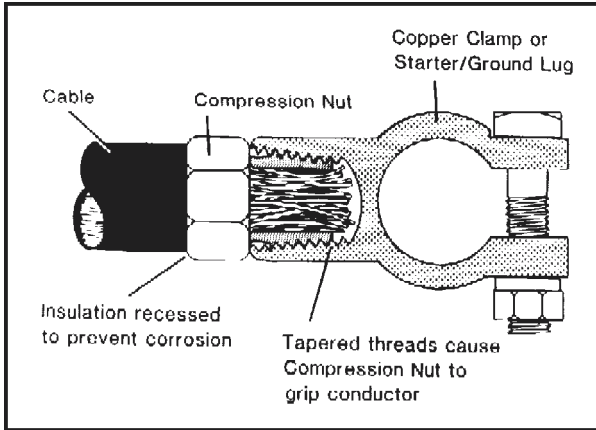

*Cut-away view*

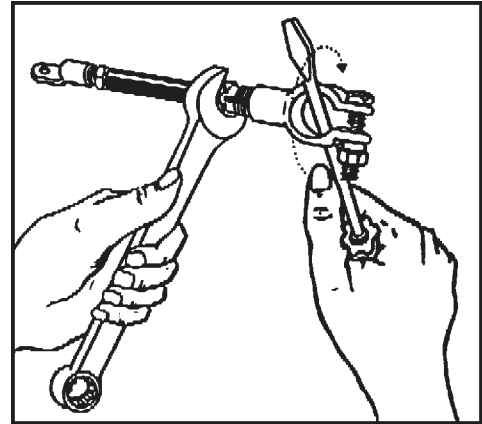

*Assembles with common hand tools.*

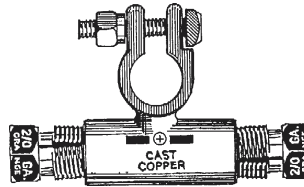
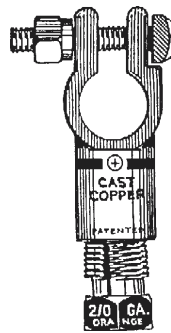

Cable Gauge	Color	Straight Clamps	Flag Connectors	Heavy Wall Lugs 3/8" hole	1/2" hole	Compression Nuts
4	Gray	26-433	26-439	26-445	-	26-453
1 & 2	Green	26-434	26-440	26-446	-	26-454
1/0	Black	26-435	26-441	26-447	26-449	26-455
2/0	Orange	26-436	26-442	26-448	26-450	26-456
3/0	Purple	26-437	26-443	-	26-451	26-457
4/0	Yellow	26-438	-	-	26-452	26-458

UNIVERSAL POST (fits both positive and negative posts). All Pkg: 5 each

*"Patience has its limits.  
Take it too far and it's  
cowardice"*

- George Jackson

## Cable/Battery Terminal Gauge

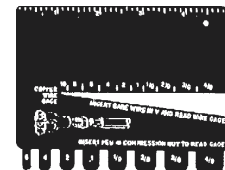

Determines the correct size of copper wire from 10 to 4/0 gauge. Also measures battery terminal compression nuts. **Part No. 42-001**

# Emergency Style Battery Terminals

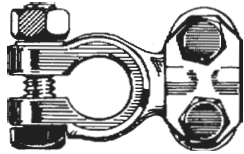

## Emergency Battery Terminal

For automotive use. Made of lead.

Part No.	Cable Size	Polarity	Pkg
4500	2 ga. - 2/0	Universal	10

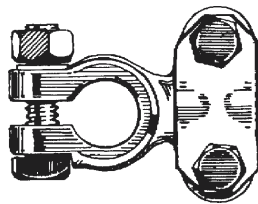

## Emergency Heavy Duty Truck Terminal

For trucks and heavy equipment. Made of lead.

Part No.	Cable Size	Polarity	Pkg
4501	1 ga.- 4/0	Universal	8

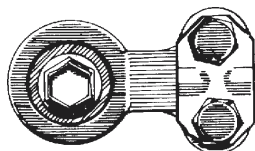

## Emergency Side-Mount Battery Terminal

Universal stud size. Made of lead.

Part No.	Cable Size	Polarity	Pkg
4503	2 ga. - 2/0	Universal	10

**SERVICE IS OUR PRIORITY!  
OUR COMMITMENT IS TO  
MEET YOUR NEEDS!**

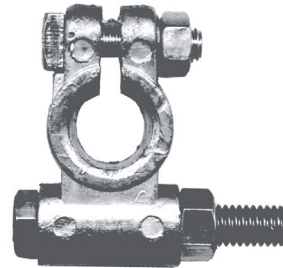

## Diesel Truck/Military Terminal

Low profile, only 11/16" high. Long bolt (2 1/4") permits multiple or parallel connections. Made of lead. Meets MS75004-1 and MS75004-2.

Part No.	Stud Size	Polarity	Pkg
4510	3/8-16	Universal	5

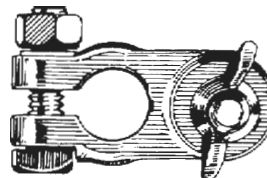

## Brass Marine Battery Terminal

Lead plated. Wing nut included.

Part No.	Stud Size	Polarity	Pkg
4605	3/8-16	Positive	5
4606	5/16-18	Negative	5

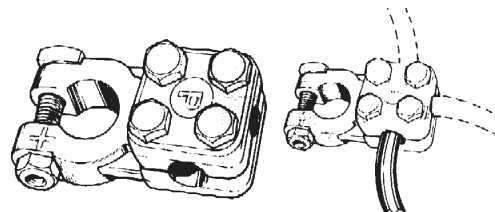

## 3-Way Heavy Duty Truck Clamp

Fits 4 ga - 2/0 cable. Made of lead.

Part No.	Post	Pkg
4511	Positive	2
4512	Negative	2

*Emergency Battery Terminals are designed for a "quick-fix" when a more permanent repair is not practical. As soon as possible, replace any clamp-type terminal with a permanent environmentally sealed connection such as our CRIMP-TITE BATTERY TERMINALS (Crimp or use Solder Slugs) or compression battery terminals, each one should be fitted with heavy wall heat shrinkable tubing.*



# Extra Thick Power Lugs

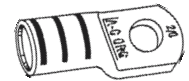

Crimp starter lugs with the same die setting as the battery terminals! Wall thickness is 80% thicker than standard lugs for increased conductivity and greater crank force. Wide pads for more surface contact. Color-coded and die-stamped to match most crimping dies. May be crimped or soldered. Use power lugs in the most demanding applications: trucks, buses and heavy equipment. 100% copper, tin plated.

Part No.	Cable Size	Stud Size	Thick-ness	Overall Length	Color/ Die Setting	Pkg Qty
2013B	6	1/4"	0.110"	1.350"	BLUE (K-K)	10
2014B	6	5/16"	0.110"	1.350"	BLUE (K-K)	10
2016B	4	1/4"	0.120"	1.495"	GRAY (J-H)	10
2017B	4	5/16"	0.120"	1.495"	GRAY (J-H)	10
2018B	4	3/8"	0.115"	1.495"	GRAY (J-H)	10
2024B	1 & 2	5/16"	0.165"	1.850"	PINK (H-H)	5
2025B	1 & 2	3/8"	0.165"	2.008"	PINK (H-H)	5
2026B	1 & 2	1/2"	0.165"	2.205"	PINK (H-H)	5
2029B	1/0	3/8"	0.130"	2.000"	BLACK (E-A)	5
2030B	1/0	1/2"	0.130"	2.000"	BLACK (E-A)	5
2033B	2/0	3/8"	0.130"	2.250"	ORANGE (A-C)	5
2034B	2/0	1/2"	0.130"	2.250"	ORANGE (A-C)	5
2037B	3/0	3/8"	0.170"	2.430"	PURPLE (A-B)	5
2038B	3/0	1/2"	0.170"	2.430"	PURPLE (A-B)	5
2041B	4/0	3/8"	0.180"	2.500"	YELLOW (A-A)	5
2042B	4/0	1/2"	0.180"	2.500"	YELLOW (A-A)	5

## Starter Lugs



Standard thickness. Flared ends for easy entry. Can be crimped or solder. High grade copper construction.

Part No.	Wire Size	Stud Size	Pkg Qty
2013	6 ga	1/4	25
2014	6 ga	5/16	25
2016	4 ga	1/4	25
2017	4 ga	5/16	25
2018	4 ga	3/8	25
2020	2 ga	5/16	25
2021	2 ga	3/8	25
2022	2 ga	1/2	25
2024	1 ga	5/16	25
2025	1 ga	3/8	25
2026	1 ga	1/2	25
2029	1/0	3/8	25
2030	1/0	1/2	25
2033	2/0	3/8	25
2034	2/0	1/2	25
2037	3/0	3/8	10
2038	3/0	1/2	10
2041	4/0	3/8	10
2042	4/0	1/2	10

## Cable Splices

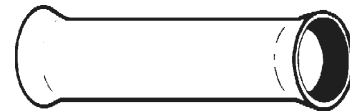

Double flared for easy entry. Crimp or solder. Tin plated copper construction.

Part No.	Wire Size	Length	Pkg Qty
02-300	6 ga	1.075	25
02-301	4 ga	1.215	10
02-302	2 ga	1.350	10
02-303	1 ga	1.350	10
02-304	1/0	1.550	5
02-305	2/0	1.800	5
02-306	3/0	1.900	5
02-307	4/0	2.000	5

# Red Hot Deals!

Check out our current specials and new items on our website at <http://www.mpi-online.com>



# Battery Bolts & Nuts

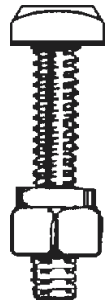

**Square Hd. Bolt with Collared Nut**

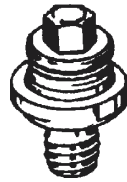

**Side-Mount Bolt**



**Stud-top Nut**

Meets OEM, SAE and Mil specifications. Zinc finish.

Part No.	Item	Pkg
26-465	1/4-20 x 1-1/4 sq. hd. bolt (only)	100
4573	5/16-18 x 1-1/4 sq. hd. bolt w/nut	100
4574	5/16-18 x 1-3/8 sq. hd. bolt w/nut	100
4575	5/16-18 collared nut (only)	100
4568	3/8-16 side-mount battery bolt	10
26-258	3/8-16 stud-top nut	10

# QuickHold™ Battery Hold-Downs



- Adjustable
- Locks securely
- Corrosion proof
- Nonconductive

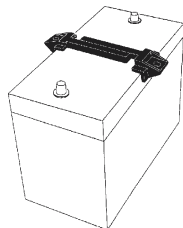

Part No.	Min. Length	Max. Length	Vent Cover Style
4616	5-3/4"	8-1/2"	Flush
4617	8-1/4"	13-1/4"	Flush
4618	5-1/4"	7-1/2"	Offset*

\*Use offset style for raised vent cover applications.



# Battery Accessory Bolts

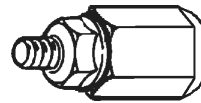

**Top Post**

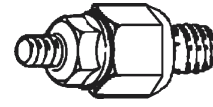

**Side Post**

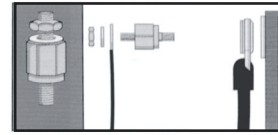

*Side post application*

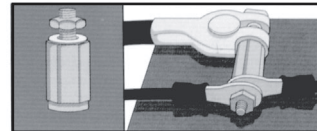

*Top post application*

Connect accessories directly to your battery. Ideal for radios, lights, winches, and hydraulic pumps.

## 1/4 X 5/16 Top Post Adapter Nut

Replaces 1/4-20 collared nuts on top post batteries. Includes 5/16-18 x 3/4 stud for accessory wires.

Pkg: 10 each. **Part No. 26-466**

## 5/16 X 5/16 Top Post Adapter Nut

Replaces 5/16-18 collared nuts on top post batteries. Includes 5/16-18 x 3/4 stud for accessory wires.

Pkg: 10 each. **Part No. 26-467**

## **new** 3/8 X 3/8 Top Post Adapter Nut

Replaces 3/8-16 collared nuts on top post batteries. Includes 3/8-16 x 3/4 stud for accessory wires.

Pkg: 10 each. **Part No. 26-467B**

## Side Post Adapter Bolt

Replaces regular 3/8-16 side terminal battery bolts. Includes 5/16-18 x 1/2" stud for accessory wires. Pkg: 10 each. **Part No. 26-468**



**WRIGHT TOOL**

70 years of quality and innovation

**Call now for a free Wright Tool Catalog!**

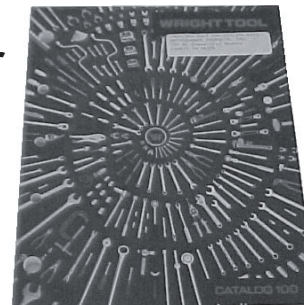



# Industrial Battery Connectors

(Also called Anderson® Connectors, Fork Lift Connectors or Modular Connectors)

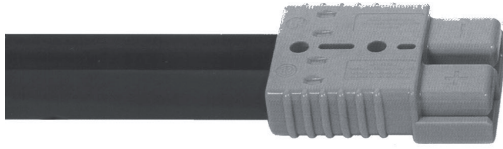

## SELF-MATING HOUSINGS!

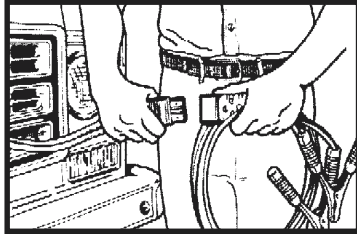

## HIGHEST QUALITY - UL®, CSA®, ISO®

Provides a quick, safe and reliable way to connect booster cables and charging systems. Nonconductive and high impact polycarbonate housings can be screw-mounted to vehicles' frame for permanent installation and to prevent broken contacts. Silver plated copper contacts deliver maximum current and long life. Flared barrel for easy installation. Uses: fork lift trucks, golf cars, remote starters, booster and charger hookups.

## SAFE POLARITY PROTECTION COLOR-KEYED FOR VOLTAGE PROTECTION!

Diagram	Description/Use
<p>Battery to Equipment/Vehicle</p>	Connect and disconnect a battery or group of batteries from a vehicle or piece of equipment such as a truck, forklift, generator, floor scrubber, golf cart, personnel mover, etc.
<p>Vehicle Battery to Charger</p>	Connect and disconnect a battery or group of batteries from a charger.
<p>Vehicle to Vehicle</p>	Jump start a vehicle from a service vehicle.
<p>Equipment in a Circuit</p>	Connect and disconnect UPS/battery back up systems. Link equipment together, adding or subtracting equipment from a circuit as needed.

## Housings are now color-keyed!

This means gray housings will only plug into gray housings. Gray housings won't plug into red or blue housings. Similarly, red housings plug into other red housings, not blue housings. The color-keyed feature makes it possible for you to differentiate voltage of your electrical circuits. For example if you don't want to plug a 36 volt battery pack into a 48 volt charger.

## Industry recommendations are as follows:

Housing	Voltage
Red	24
Gray	36
Blue	48

Part No.	Amperage	Housing Color	Cable Size	Barrel I.D.
26-481	50	Red	6	.221"
26-482	175	Red	1/0	.437"
26-483	350	Red	2/0	.484"
26-459	50	Gray	6	.221"
26-460	175	Gray	1/0	.437"
26-461	350	Gray	2/0	.484"
26-484	175	Blue	1/0	.437"
26-485	350	Blue	2/0	.484"

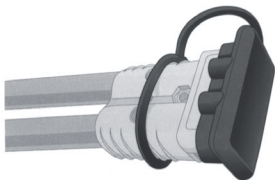

## Protective Caps

Protect contacts from dirt, dust and road salt. Molded tether attaches cap to connector housing preventing loss. Color: black. **Pkg: 5 each**

**Pkg: 1 each\***  
(Order 2 units for new installations.)

Part No.	Fits Connector Size
26-486	50 amps
26-487	175 amps
26-488	350 amps

\*NOTE: Order 2 units when needed, especially when installed for the first time. Although connectors are sold individually (1 housing and 2 contacts) when needed, more than one unit is usually required on many installations.



# Battery Slugs



Pre-measured, pre-fluxed pieces of solder that have been sized to provide the correct amount of solder for each size of cable connectors. Color coded to industry standards. Battery Slugs provide a simple and cost efficient way to achieve a perfect connection.

## ADVANTAGES

- Better contact; less voltage drop at connection.
- Use with top-post clamps, side-post clamps, stud-post clamps, and all starter lugs.
- Little training or operator skill required.
- No crimping, therefore no punctured insulation.
- No need for expensive crimping tools.

Part No.	Size	Color	Qty
02-368	4 ga.	Grey	12
02-369	2 ga.	Green	12
02-370	1 ga.	Pink	12
02-371	1/0	Black	12
02-372	2/0	Orange	12
02-373	3/0	Purple	6
02-374	4/0	Yellow	6
21-324	Liquid Flux, 4 oz.	bottle	1

## Solder Slug Installation

Tools required: utility knife, propane torch and bench vise.

STRIP THE PROPER SIZE CABLE so that the exposed cable will reach all the way to the bottom of the battery terminal or lug, making sure the insulation fits snugly against the top.

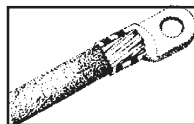

PLACE THE PROPER BATTERY SLUG INTO TERMINAL. Secure the battery terminal in vise. Slide the proper size shrink tubing over the cable. Apply several drops of liquid flux to the exposed wire.

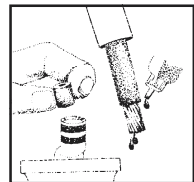

HEAT BASE OF TERMINAL while applying gentle downward pressure on the cable. Allow the cable to slide into the terminal until the insulation is snug against the top of the terminal. Remove the heat.

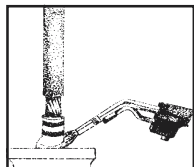

INSTALL SHRINK TUBING. Slide the heat shrinkable tubing over the connection and apply indirect heat to the tubing. Allow the assembly to cool down before installation.

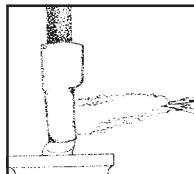

# The Crimpace

## Battery Terminal Crimping Tool

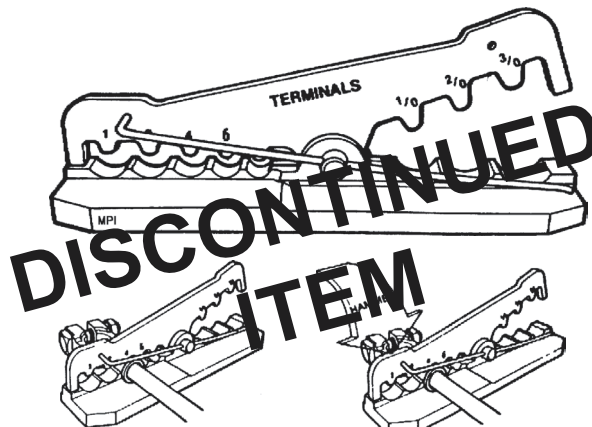

1. Insert assembly.

2. Hammer home or use a bench vise.

Lightweight. Crimp range: 6 to 4/0 lugs and terminals. Spring action holds lug firmly in place. Positive stop to assure perfect crimps. Used with hammer or vise.  
Part No. 4612

# Battery Cable Crimping Tool

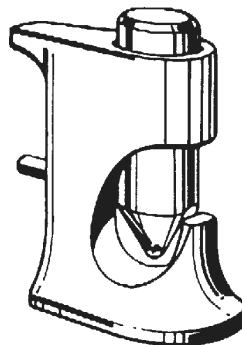

## FOR USE WITH HAMMER OR VISE

Inexpensive, simple crimper for use with 8 - 4/0 gauge connectors. Scale on the side of tool assures proper crimping. Spring loaded pin locks in "up" position for loading. When released, pin hold connector securely during crimping. 6 month limited warranty.

Part No. 4521



# The Hex Crimp

## Battery Terminal Crimping Tool

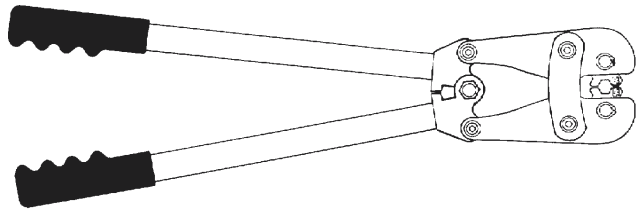

### Features:

- Unique "Hex" crimping dies
- Fully insulated handles.
- Rotating dies mean no loose pieces.
- Ability to crimp all crimp-able terminals.
- Solid construction.

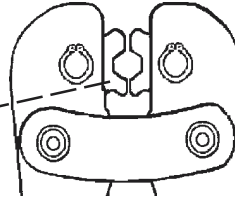

### 2-YEAR LIMITED WARRANTY

Part No.	Crimp Range	Length
1090	6 ga. to 4/0	26"

# Battery Cable

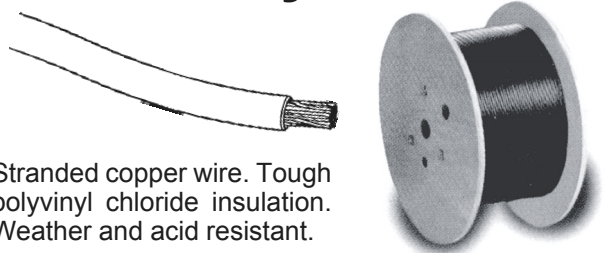

Stranded copper wire. Tough polyvinyl chloride insulation. Weather and acid resistant.

Part No.	Color	Gauge	Conductor Diameter*	Pkg Qty
4560	Black	6	.210"	50'
4560R	Red	6	.210"	50'
4561	Black	4	.244"	25'
4561R	Red	4	.244"	25'
4562	Black	2	.322"	25'
4562R	Red	2	.322"	25'
4563	Black	1	.370"	25'
4563R	Red	1	.370"	25'
4564	Black	1/0	.417"	25'
4564R	Red	1/0	.417"	25'
4565	Black	2/0	.473"	25'
4565R	Red	2/0	.473"	25'
4566	Black	3/0	.523"	25'
4567	Black	4/0	.604"	25'

*TIP: Always install the same size or heavier (never lighter). In cold climates, use a heavier cable to improve starting.*

# Quick-Cutter 1

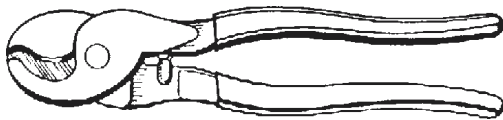

Cuts all copper cable thru 2/0. Made of forged steel. Insulated handles. Length: 9". *6 month limited warranty. Does not cut steel. Part No. 4614*

# Quick-Cutter 2



Cuts copper cable up to 250 MCM (6/0). Insulated handles. Length: 24". Can be resharpened. *6 month limited warranty. Does not cut steel. Part No. 4615*

# Welding Cable

Neoprene jacket. 600 volt rating. Fine stranded copper wire. Flexible in cold temperatures and easy to route in tight spaces. Resistant to oil, flame, heat, weather, UV rays and abrasion. Temperature range: -40°F to 194°F. Color is black.

Part No.	Gauge	Conductor Diameter*	Pkg Qty
26-473	4	.260"	100'
26-474	2	.325"	100'
26-475	1	.365"	100'
26-476	1/0	.430"	100'
26-477	2/0	.470"	100'
26-478	3/0	.520"	25'
26-479	4/0	.600"	25'

### CABLE ILLUSTRATIONS ACTUAL SIZE

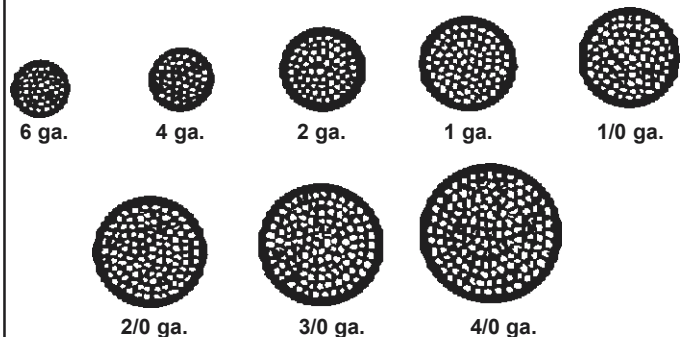

# Battery Maintenance Tools

## Battery Terminal Cleaner

Foam action cleaner penetrates and emulsifies dirt, grease, acid and contaminants. Neutralizes acid residues increasing the pH to a safe level. Spray liberally on battery, terminals, metal connectors, brackets and nearby areas. Master brand.



Part No.	Net Weight	Pkg
MS-BTC-8 .....	Net Wt. 6 oz. Aerosol .....	12

## Quick-Cote+ Protective Compound



Special formula seals terminals and connectors against corrosion, moisture, dirt and oil. Neutralizes acid. Won't clog like aerosols. Seals out acid and water. Brush-on application stays put, won't drip or evaporate.

Part No.	Description	Pkg
QC-6023-001 ....	8 oz. brush-top can .....	6

## Battery Protector

Acid fumes from batteries cause corrosion on nearby metal parts. This corrosion not only shortens the life of these components but can lead to premature battery failure by increasing battery drain. Battery Protector seals battery terminals with a long lasting protective film to eliminate corrosion and extend battery life. Master brand.



Part No.	Net Weight	Pkg
MS-BP-8 .....	Net Wt. 6 oz. Aerosol .....	12

## Battery Terminal Brush

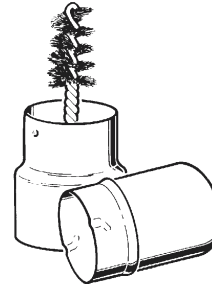

Removes corrosion and dirt from cable clamps and terminal posts. Metal housing. **Part No. 4578**

## Battery Terminal Protective Washers

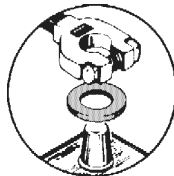

Protective washers made of nonwoven material, impregnated with anti-corrosive inhibitors. Prevents power robbing corrosion build-up on top post and threaded stud battery terminals. 100 per metal can.

Part No.	Color	Pkg Qty
QC-6622-100B .....	Black .....	1 can
QC-6622-100R .....	Red .....	1 can

## Battery Filler Bulb

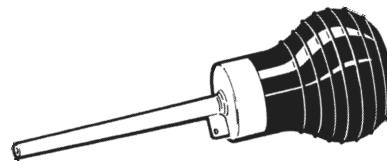

Rubber bulb has 6 oz. capacity. Ideal for all fluids including battery acid. 6" vinyl spout for easy vent access. **Part No. 4608**

## Battery Filler

Shuts off automatically when battery cell is at proper level. 2 quart capacity. Use with battery acid or water.

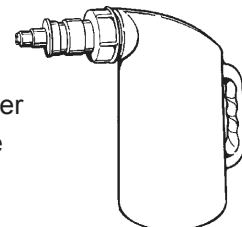

**Part No. 12-75030**

# Booster Cables, Clamps & Alligator Clips

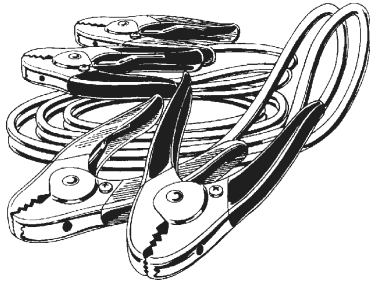

## Heavy Duty Booster Cables & Clamps

Tangle-free cable, 100% fine stranded copper wire.

Part No.	Amps	Length	Wire	Pkg
4583	400	20 ft.	4 ga.	1 set
02-347	500	20 ft.	2 ga.	1 set
REPLACEMENT BOOSTER CLAMPS				
02-349	Parrot style, 500 amp, red/black			1 pr

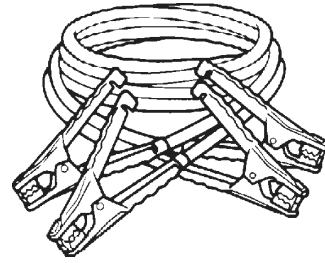

## Standard Booster Cables & Clamps

Tangle-free cable, 100% fine stranded copper wire.

Part No.	Amps	Length	Wire	Pkg
4582	400	12 ft.	4 ga.	1 set
REPLACEMENT BOOSTER CLAMPS				
4585	Standard 400 amp, red/black			1 pr

## 800 Amp Super Clamps

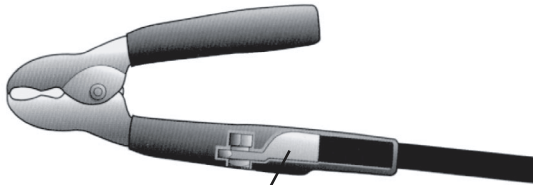

Accepts size 1 ga. to 3/0 lugs\*

Use to to build or repair your own super duty booster cables. 800 amp capacity. Ideal for truck, bus, farm, commercial and industrial applications. Jaws grip top-post, stud and side-post terminals. Red and black insulated grips. Heavy duty plated steel springs and solid copper contacts. Pkg: 1 PAIR\*\*. **Part No. 02-349B**

\*Cable Lugs not included. \*\*Sold in pairs only (1 red, 1 black).

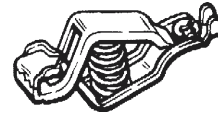

## Tester Clips

Plated steel.

Part No.	Amp	Length	Pkg
4592	10	2"	10
4593	25	2-3/4"	10
4594	50	4-1/4"	5

## Alligator Clips

Nickel Plated Steel

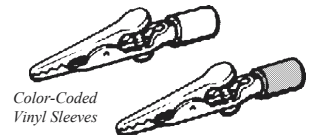
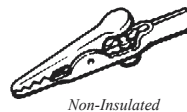

Part No.	Amp	Length	Style	Pkg
4588	10	2"	Non-insulated	10
4589	10	2"	Red vinyl sleeve	10
4590	10	2"	Black vinyl sleeve	10

## Insulated Charger Clips



Heavy duty 50 amp capacity exceeds most on the market. Color coded vinyl boots protect crimp ears.

Part No.	Amp	Color	Pkg
4595	50	Red	5
4596	50	Black	5

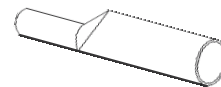

## Alligator Clip Insulators

Part No.	Color	Pkg
4591R	Red	10
4591B	Black	10

# Miniature Light Bulbs



## Automotive Bulbs

All 12 Volts • Pkg: 10 each

Part No.	Industry No.	Typical Applications	Bulb Type
26-329	24	Marker/License	15
26-387*	24NA	Parking	15
26-093	53	Indicator	4
26-096	57	Instrument	4
26-099	67	Parking/License	4
26-330	74	Indicator/Radio	14
26-101	89	Dome/Trunk	4
26-102	90	Dome/Trunk	13
26-104	97	Dome/Instrument	4
26-106	158	Instrument	2
26-109	194	Instrument	2
26-110	194A	Instrument	2
26-389*	194NA	Parking	2
26-111	198	Stop/Turn	1
26-114	211-2	Dome/Trunk	6
26-331	212-2	Dome/Trunk	6
26-332	561	Dome/Interior	12
26-333	906	Courtesy	2
26-334	912	3rd Stop	10
26-391	916	Parking	10
26-335	921	3rd Stop	10
26-119	1003	Dome/Interior	3
26-120	1004	Dome/Engine	1
26-123	1073	Front Turn	3
26-126	1141	Rear Turn	3
26-130	1156	Front Turn	3
26-131	1157	Stop/Turn	1
26-132	1157A	Front Turn	1
26-133*	1157NA	Front Turn	1
26-141	1816	Instrument	5
26-143	1891	Courtesy	5
26-392	1889	Instrument	5
26-144	1893	Instrument	5
26-145	1895	Instrument	4
26-134	2057	Stop/Turn	1
26-135*	2057NA	Front Turn	1
26-136	2357	Stop/Turn	1
26-137*	2357NA	Turn/Parking	1
26-394	2396	Turn/Park	3
26-138	3057 (2358,2457)	Stop/Turn	7
26-139*	3057NA (2358NA,2457NA)	Turn/Parking	7
26-127	3157 (2359,2459)	Stop/Turn	7
26-128*	3157NA (2359NA,2458NA)	Turn/Parking	7
26-336	3155	3rd Stop	7
26-337	3156	Corner/Backup	7
26-395	DE3022	Dome	9
26-396	DE3175	Dome	9

\* NA: Natural amber glass, not a coating.

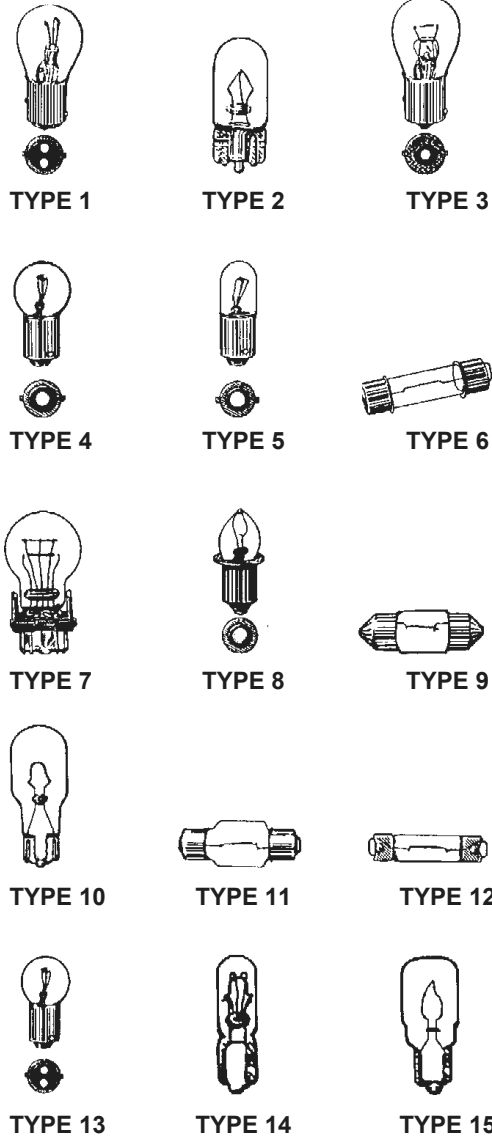

**WE STOCK AU-VE-CO  
LAMP SOCKETS &  
PIGTAILS**



CALL MPI  
FOR YOUR  
FREE  
AU-VE-CO  
CATALOG!

# Flashlight Bulbs



Part No.	Industry No.	Application	Pkg Qty
<b>STANDARD FLANGE BASE</b>			
17-037	PR2	2, D Cell	10
17-038	PR3	3, D Cell	10
17-039	PR4	2, D Cell	10
17-040	PR6	2, D Cell	10
17-041	PR12	5, D Cell	10
17-042	PR13	6V Cell	10
<b>STANDARD SCREW BASE</b>			
17-043	14	2, D Cell	10
17-044	222	2, AA Cell	10
<b>KRYPTON FLANGE BASE (2 per card)</b>			
17-114	K1	2, C Cell	1 Pkg
17-115	K2	2, D Cell	1 Pkg
17-116	K3	3, D Cell	1 Pkg
17-117	K4	2, AA Cell	1 Pkg
17-118	K13	6V Cell	1 Pkg

*Krypton bulbs may be substituted for standard flange base flashlight bulbs.*

The Coca-Cola name in China was first read as “Kekoukela”, meaning “Bite the wax tadpole” or “female horse stuffed with wax”, depending on the dialect. Coke then researched 40,000 characters to find a phonetic equivalent “kokou kole”, translating into “happiness in the mouth.”



# Sealed Beam Headlamps

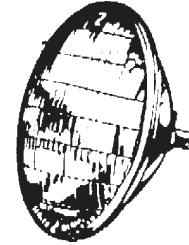

Part No.	Industry No.	Description	Pkg Qty
<b>INCANDESCENT</b>			
26-149	6014	7" Round, Hi-Lo	12
26-150	4651	4"x6.5" Rect., Hi	12
26-151	4652	4"x6.5" Rect., Lo	12
26-187	6052	5.63x7.88 Rect.,Hi-Lo	12
<b>HALOGEN</b>			
26-320	H-5006	5.75" Round, Lo	12
26-321	H-5001	5.75" Round., Hi	12
26-322	H-6024	7" Round., Hi-Lo	12
(Replaces 6014, H-6014 and H-6017)			
26-323	H-4651	4"x6.5" Rect., Hi	12
26-324	H-4656	4"x6.5" Rect., Lo	12
26-325	H-6054	5.63x7.88 Rect.,Hi-Lo	12
<b>TRACTOR/TRUCK</b>			
26-338	4411	4.5" Tractor/Utility	12
26-339	4412	5" Auto Fog/Driving	12
26-341	4416	4" Spot Lamp	12
26-342	4419	5" Tractor/Utility	12
26-344	4509	4" Tractor/Utility	12
26-345	4537	5" Tractor/Utility	12
26-346	6015	7" Tractor	12

# Late Model Halogen Bulbs



Part No.	Industry No.	Description	Pkg Qty
26-326	9004	Hi-Lo	20
26-327	9005	Hi	20
26-328	9006	Lo	20
26-347	9007	Hi-Lo	20



# Automotive Glass Fuses

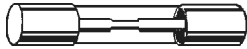

- **AGC Type** - All Glass
  - **SFE Type** - Society of Fuse Engineers
- Packed 5 per inner sleeve, 5 sleeves per box.*

Part No.	Industry No.	Length	Pkg Qty
26-012	AGC 1	1-1/4"	25
26-014	AGC 2	1-1/4"	25
26-016	AGC 3	1-1/4"	25
26-017	AGC 4	1-1/4"	25
26-018	AGC 5	1-1/4"	25
26-020	AGC 7-1/2	1-1/4"	25
26-021	AGC 10	1-1/4"	25
26-022	AGC 15	1-1/4"	25
26-023	AGC 20	1-1/4"	25
26-024	AGC 25	1-1/4"	25
26-025	AGC 30	1-1/4"	25
26-046	SFE 4	5/8"	25
26-048	SFE 7 1/2	7/8"	25
26-049	SFE 9	7/8"	25
26-050	SFE 14	1-1/16"	25
26-051	SFE 20	1-1/16"	25
26-052	SFE 30	1-1/16"	25

# ATM Mini® Blade Fuses



**Color-coded miniature blade style fuses.**  
*Packed 5 per inner sleeve, 5 sleeves per box.*

Part No.	AMP Rating	Color	Pkg Qty
02-400	ATM-2	Gray	25
02-401	ATM-3	Violet	25
02-402	ATM-4	Pink	25
02-403	ATM-5	Tan	25
02-404	ATM-7 1/2	Brown	25
02-405	ATM-10	Red	25
02-406	ATM-15	Blue	25
02-407	ATM-20	Yellow	25
02-408	ATM-25	White	25
02-409	ATM-30	Green	25

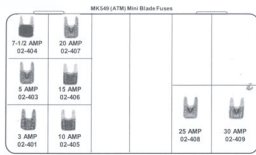

**ATM MINI® BLADE FUSE MAINTENANCE KIT**  
 8 SIZES, 3 - 30 AMP IN A CLEAR PLASTIC BOX.  
**PART NO. MK549**

# ATC® Blade Fuses

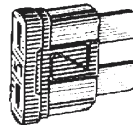

**Color coded standard blade style fuses.**  
*Packed 5 per inner sleeve, 5 sleeves per box.*  
 Note: ATO fuses and ATC fuses are interchangeable.

Part No.	AMP Rating	Color	Pkg Qty
26-053	ATC-3	Violet	25
26-054	ATC-4	Pink	25
26-055	ATC-5	Tan	25
26-056	ATC-7 1/2	Brown	25
26-057	ATC-10	Red	25
26-058	ATC-15	Blue	25
26-059	ATC-20	Yellow	25
26-060	ATC-25	White	25
26-061	ATC-30	Green	25

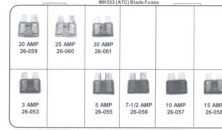

**ATC® BLADE FUSE MAINTENANCE KIT**  
 8 SIZES, 3 TO 30 AMP (4 AMP NOT INCLUDED) IN A CLEAR PLASTIC BOX. **PART NO. MK553**

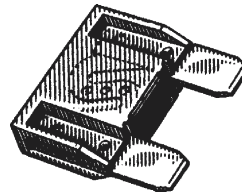

# Maxi® Blade Fuses

**Color coded large blade style fuses.** *Packed 1 per inner sleeve, 2 sleeves per box.*

Part No.	AMP Rating	Color	Pkg Qty
02-455	MAX-20	Yellow	2
02-456	MAX-30	Green	2
02-457	MAX-40	Orange	2
02-458	MAX-50	Red	2
02-459	MAX-60	Blue	2

**MAXI® BLADE FUSE MAINTENANCE KIT**  
 5 SIZES, 20 TO 60 AMP MAXI FUSES IN A CLEAR PLASTIC BOX.  
**PART NO. MK649**

# Fuse Assortments

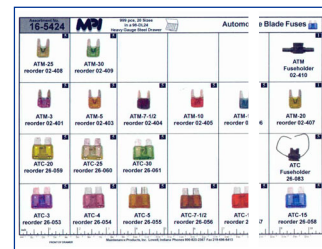

**BLADE FUSE ASSORTMENT** 19 SIZES, ATC AND ATM BLADE FUSES, WITH FUSEHOLDERS IN 24 COMPT. STEEL DRAWER. **PART NO. 16-5424**

**GLASS & BLADE FUSE ASSORTMENT**  
 32 SIZES, GLASS, ATC AND ATM BLADE FUSES, WITH FUSEHOLDERS IN 32 COMPT. STEEL DRAWER.  
**PART NO. 16-5532 (NOT SHOWN)**



# Fuseholders

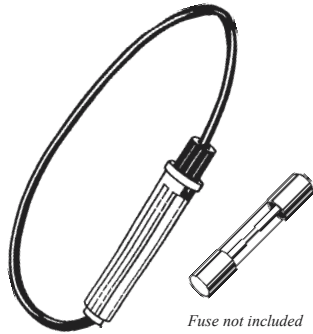

Fuse not included

## In-Line Fuseholders

Fuse included. Wire length: 8"

Part No.	Amps	Wire Gauge/Color	Pkg Qty
26-085•	8	14 AWG, Brown	10
26-086	15	12 AWG, Blue	10
26-087	20	12 AWG, Green	10
26-080	30	12 AWG, Black	10

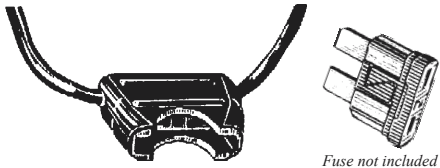

Fuse not included

## ATC Fuse Holder

Supplied with two 4½" leads. For use with 3 to 20 amp ATC standard blade fuses. Pkg: 10 each.

Part No. 26-083•

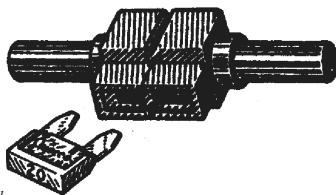

Fuse not included

## ATM Mini Fuse Holder

Insert wire into barrel and crimp with wire tool. Use with 2 to 20 amp ATM mini blade fuses.

Pkg: 5 each. Part No. 02-410•

Part numbers marked with bullet (•) in fuse assortment #16-5532.



# Circuit Breakers

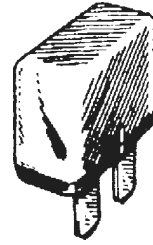

## GM Plug-In Circuit Breaker

- 30 Amp, 12 Volt
- For many GM cars
- Pkg. Qty. 5 each

Part No. 26-077

## Stud Type Circuit Breaker

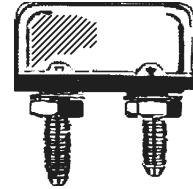

- 6, 12, & 24 Volt
- Automatic reset

Part No.	Amp	Pkg
26-064	10	5
26-065	15	5
26-066	20	5
26-067	25	5
26-068	30	5
26-069	40	5

## Fuse Clip Circuit Breaker

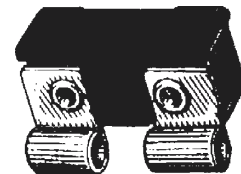

- Replaces SFE & AGC fuses
- 12 Volt • Automatic reset

Part No.	Amp	Pkg
26-070	10	5
26-071	15	5
26-072	20	5
26-073	25	5
26-074	30	5

**SAVE WHEN YOU  
BUY IN QUANTITY!**

# Automotive Flashers

## Standard Round Flashers



Part No.	Trade No.	Voltage	Prongs	Pkg Qty
26-089	552	12	2	5
26-090	550	12	3	5



## Electronic Flashers

12 volt unit is capable of operating up to ten lamps. Can be used in foreign vehicles. Meets all DOT 108 requirements. Impact resistant, thermoplastic cover. When one or more lights fail, electronic flashers continue to operate the remaining lights, thus a visual inspection is required.

Part	Voltage	Style	Pkg
26-078	12	2-prong	1

# The Doctor is in!



**Drill Doctor**  
Drill Bit Sharpener

See page 338

# Truck Flashers

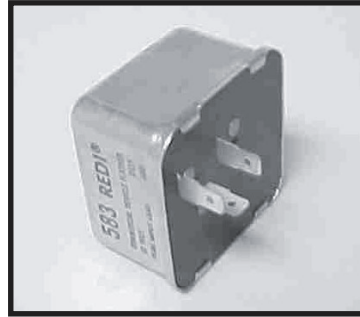

## Commercial Vehicle Flashers

- Nickel alloy parts for corrosion protection
- Operates from -40°F to 200°F
- Combination signal & hazard warning application
- Will flash 2 to 4 bulbs (32 C.P.) standard or long life lamps (plus pilot bulbs) for turn signal and 2 to 8 for hazard warning.

Part	Trade	Volts	Prongs	Pkg
26-075	582	12	2	5
26-076	583	12	3	5

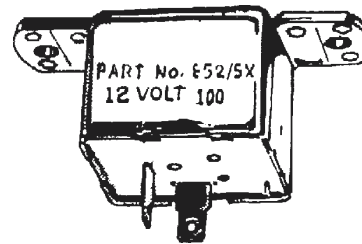

## 5X Type Flashers

- Heavy duty coil operates over a wide voltage range
- Positive reset assures dependable cycling.
- Variable load.
- Replaces costly transistorized flashers.
- Lasts at least 5 times longer than other flashers.
- Continues to operate at a lower voltage than thermal flashers.
- Gives long lasting protection when trucks are parked or disabled.
- Operates from -20°F to 130°F.

### Specifications

Turn signal flasher; 500 hours flashing at specified load of 2, 3, or 4 lamps. Hazard warning flasher; 180 hours flashing up to 8 lamps.

Part	Trade	Volts	Prongs	Pkg
26-092	852/5X	12	2	1

# Pigtail Connectors

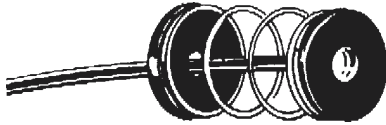

## Single Contact Pigtail Connectors

Part No.	Base	Pkg
26-301 .....	Regular .....	10



## Two-Wire Trailer Connector

Red male lead, black female lead.  
Mates with #26-311B below. 8" leads.  
**Part No. 26-311A** Pkg: 10 each

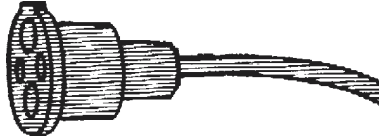

## Single Contact Waterproof Pigtail

*for all single contact regular base bulbs*

Part No.	Base	Pkg
26-304 .....	Rubber .....	10



## Two-Wire Trailer Connector

Black male lead, red female lead.  
Mates with #26-311A above. 8" leads.  
**Part No. 26-311B** Pkg: 10 each

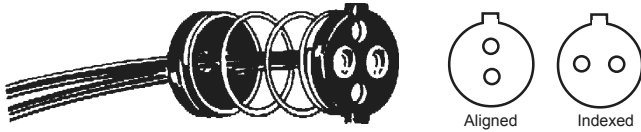

## Double Contact Pigtail Connectors

Part No.	Base	Type	Pkg
26-302 .....	Regular .....	Aligned .....	10
26-303 .....	Regular .....	Indexed .....	10

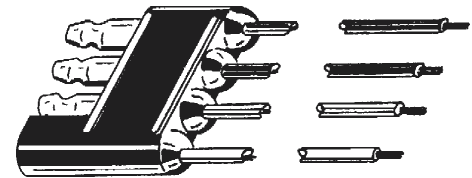

## Four-Wire Trailer Connector

3 male, 1 female. Mates with #26-315. 12" leads.  
**Part No. 26-314** Pkg: 10 each

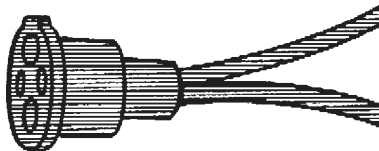

## Double Contact Waterproof Pigtail

*for all double contact regular base bulbs*

Part No.	Base	Type	Pkg
26-305 .....	Rubber .....	Aligned .....	10

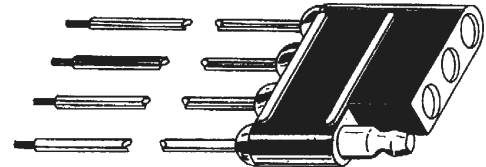

## Four Wire Trailer Connector

1 male, 3 female. Mates with #26-314. 12" leads.  
**Part No. 26-315** Pkg: 10 each

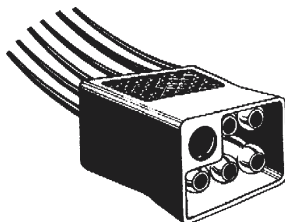

## Six Pole Shrouded Connectors

5 male, 1 female. Mates with #26-317. 12" leads.  
**Part No. 26-316** Pkg: 5 each

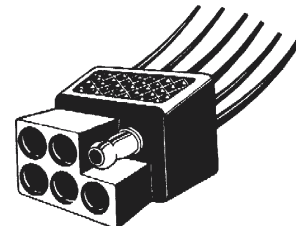

## Six Pole Shrouded Connector

1 male, 5 female. Mates with #26-316. 12" leads.  
**Part No. 26-317** Pkg: 5 each



# Truck Wheel Studs & Nuts

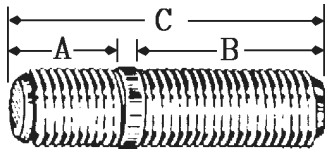

## Wheel Studs

High Tensile Steel. Zinc finish.  
Pkg: 25 each

Part No.	Diam.	A	B	C
03-300	5/8-11	1"	1-1/2	2-3/4
03-301	3/4-10	1-1/16	1-11/16	2-13/16

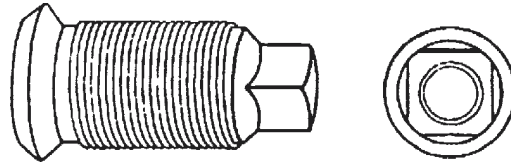

## Inner Cap Nuts

Budd style inner wheel nut. Zinc finish.

Part No.	Inner	Outer	Budd No.	Pkg
03-298	3/4-16	1-1/8" R.H.	10708	10
03-294	3/4-16	1-1/8" L.H.	10709	10

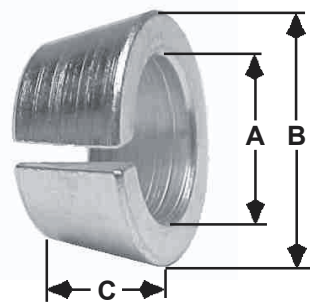

## Drive Flange Wedge

Tapered cone used on rear axle studs.  
Zinc finish.

Part No.	A	B	C	Pkg
03-306	7/16	3/4	13/32	25
03-307	1/2	13/16	5/16	25
03-308	1/2	13/16	13/32	25
03-309	5/8	1"	15/32	25

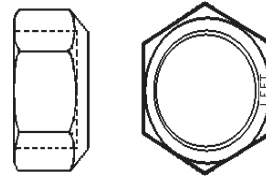

## Outer Cap Nuts

Budd style outer wheel nut. Zinc finish.

Part No.	Size	Budd No.	Pkg
03-291	1-1/8 R.H.	37891	10
03-292	1-1/8 L.H.	37892	10



Grade 2H



Washer Faced

## Wheel Nuts

(Gr. 2H Heavy Hex Nuts)

Heat treated steel. Grade marked 2H.  
Zinc finish.

Part No.	Size	W.A.F.	Pkg
03-027	5/8-11	1-1/16	50
03-028	3/4-10	1-1/4	25

## BRAKE & WHEEL PARTS

Call MPI now  
for your free  
BWP catalog!

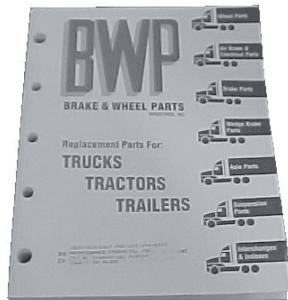

# Air Brake Replacement Parts

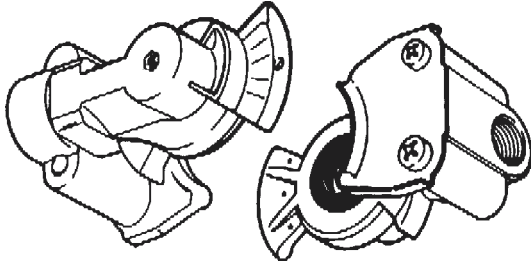

## Glad Hands

(Air Brake Hose Couplings)

Connects to 1/2" pipe. Universal glad hands will connect to all three styles.

### CAST IRON

Part No.	Application	Pkg Qty
5513	Universal, Heavy Duty	1

### ALUMINUM

Part No.	Application	Pkg Qty
5514	Emergency	1
5515	Service	1
5516	Universal	1

## Glad Hand Seals

(Rubbers)

### DOUBLE LIP

Part No.	Pkg Qty
5518	25

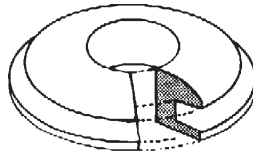

### STANDARD

Part No.	Pkg Qty
5517	25

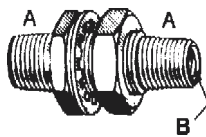
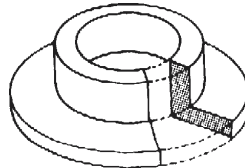

## Clamping Studs

(Bulkhead Unions)

Part No.	PIPE THREAD		Pkg Qty
	A	B	
5519	1/2	1/4	6



## Clamp-Type Air Brake Diaphragms

(Pancakes)

Part No.	Chamber Type	Dia.	Pkg Qty
03-302	12	5 1/2"	6
03-303	16	6"	6
03-304	24	7"	6
03-305	30	8"	6



## Air Brake Hose Assemblies

One male fixed end and one female swivel end with male adapter (brass). Meets S.A.E. J1402 Type B specifications.

Part No.	Hose I.D.	Length	Thrd. Size	Pkg Qty
4826	3/8	24"	1/4 npt	1
4827	3/8	30"	1/4 npt	1
4828	3/8	36"	1/4 npt	1
4829	3/8	48"	1/4 npt	1

VISIT OUR WEBSITE  
[mpi-online.com](http://mpi-online.com)

FAX ANYTIME!  
**219-696-6413**



# Tire Hardware



Standard



Locking Clip

## Ball Foot Chucks

1/4" female pipe thread.

Part No.	Description	Pkg
12-17351	Standard Chuck	1
12-17353	Locking Clip Chuck	1

### NOT FOR USE ON INFLATOR GAUGES...

These chucks are intended for use on air supply lines that come directly from the compressor, with no other valve in the line. Direct airline chucks have a shut off valve built into the chuck head.



## Tubeless Tire Valves

Part No.	Rim Hole Dia.	Length	Pkg Qty
413	.453"	1¼"	10
414	.453"	1½"	10
418	.453"	2"	10
423	.453"	2½"	10
415	5/8"	1¼"	10
425	5/8"	2"	10

## Lock-On Air Chuck

Especially useful for large truck and tractor tires. Locks onto valve when pushed on, remove by pulling back on quick-release sleeve. 1/4" female pipe thread.

Not for use with inflator gauges.

Part No. 12-060



## Tire Valve Extensions

Extend valve length for total servicing through wheel covers. Inflate, deflate, pressure check. No removal required.

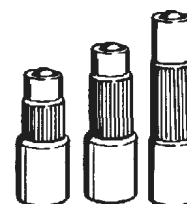

Part No.	Length	Pkg
451	3/4"	25
452	1-1/4"	25
454	2"	25

## 4-Way Tire Valve Repair Tool

Removes valve cores, repairs internal and external threads on valve and has an "easy-out" for removing broken valve cores. Part No. 12-47067

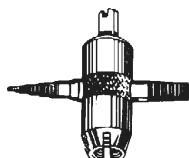

## Dual-Foot Extension Chuck

1/4" female pipe thread. Not for use with inflator gauges. Part No. 690



## Valve Cores

Part No. 12-47201 Pkg: 100 each



## Plastic Valve Caps

Part No. 12-47105 Pkg: 100 each



## Chrome Valve Caps

Part No. 12-47112 Pkg: 100 each



## Air Tank Valves

For use on pressure tanks, air horns, air lifts, compressors and other pneumatic devices. 1/8" male pipe thread. Length: 23/32" from hex to top of valve stem. Part No. 12-47951 Pkg: 2 each.



# Tire Hardware

## Pocket Size Auto Tire Gauge



Dual range — 10 to 50 psi in 1 lb. increments and 70-350 kpa in 10 kpa increments. Recessed deflator pin machined in chuck head. Pocket clip. Length: 5-3/4".  
**Part No. 12-17509**

## Pocket Size Truck Tire Gauge



Dual range — 20-120 psi in 2 lb increments and 160-880 kpa in 20 kpa increments. Features bright chrome plating, recessed deflator pin machined in chuck head and a handy pocket clip. Length: 5-3/4".  
**Part No. 12-17519**



## Dual-Foot Truck Tire Gauge



Dual head chuck for truck tire valves. Rugged construction to withstand everyday use and abuse. 10 to 150 lbs.  
**Part No. 12-17545**

Prayer of the modern American:  
"Dear God, I pray  
for patience.  
And I want it right now!"

- Oren Arnold

## Dial Truck Tire Gauge

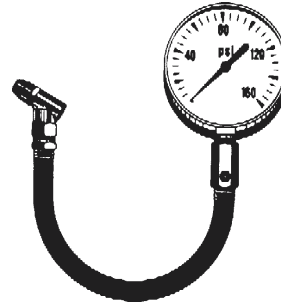

Dual range — 0-160 psi in 2 lb increments and 0-1100 kPa in 20 kPa increments. PSI black, kpa red. Swivel angle chuck, all chrome plated fittings, and a push-button valve to bleed off excess pressure. *Use on trucks or cars.* **Part No. 12-061**



## Passenger Car Dial Tire Gauge

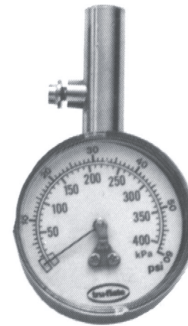

Rugged construction to withstand everyday use and abuse. 5 to 60 lbs. For passenger cars and light trucks.  
**Part No. 12-17551**

## Dual-Foot Inflator Gauge

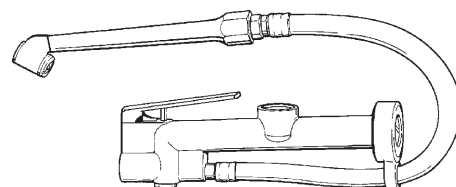

Rugged construction to withstand everyday use and abuse. Easy to read sight glass has magnified lens. 2 lb. graduations from 10 to 120 lbs. Complete with full swivel, dual head chuck. **Part No. 23-291**

# Wheel Weights



## Passenger Car Wheel Weights

"N" SERIES for passenger car rims with 13" to 15" steel wheels, except where special wheel covers require thinner design. The "N" series replaces the two piece design commonly found on vehicles manufactured in Europe. Plated and salt spray tested for rust-free performance. **Unit - 1 BOX** (50 pcs per box)

Part No.	Ascot Part No.	SIZE	
		Oz.	Grams
12-062	N025	1/4	7
12-063	N050	1/2	14
12-064	N075	3/4	21
12-065	N100	1	28
12-066	N125	1 1/4	35
12-067	N150	1 1/2	43
12-068	N175	1-3/4	50
12-069	N200	2	57
12-070	N225	2 1/4	64
12-071	N250	2 1/2	71
12-072	N275	2-3/4	78
12-073	N300	3	85

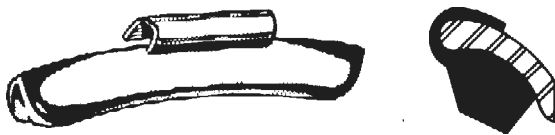

## Light Truck Wheel Weights

"LT1" SERIES for 3/4 and 1 ton light-duty trucks with tube or tubeless rims and heavier trucks with thin rim flanges. **Unit - 1 BOX** (25 pcs. per box)

Part No.	Ascot Part No.	SIZE	
		Oz.	Grams
12-074	LT1-005	1/2	14
12-075	LT1-010	1	28
12-076	LT1-015	1 1/2	43
12-077	LT1-020	2	57
12-078	LT1-025	2 1/2	71
12-079	LT1-030	3	85
12-080	LT1-040	4	113

*Note: use "N" series on 1/2 ton trucks*

# Swivel Oil Filter Wrench

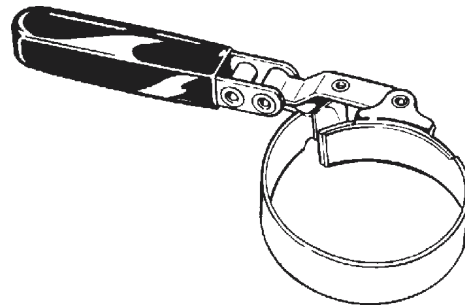

Unique swivel design offers flexibility for those hard to reach filters. Fits large filters 3-1/2" to 3-7/8" diameter. Constructed of heavy steel with a vinyl handle for a firm grip. **Part No. 12-70713**

# Brake Fluid Pump

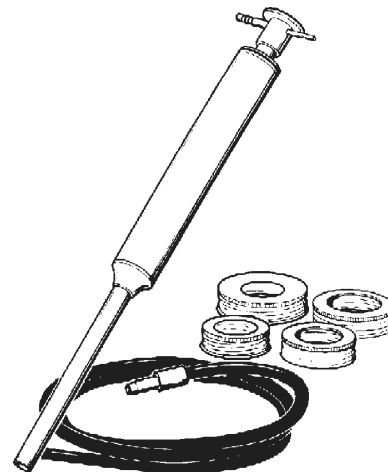

Dispenses approximately one ounce of fluid per stroke. Fits all standard one gallon cans. Comes complete with 36" flexible tubing with check valve in metal nozzle. Used with penetrants, model airplane fuel, and most any petroleum based products. **Part No. 12-70060**

**Red Hot Deals!**

Check out our current specials and new items on our website at <http://www.mpi-online.com>



# Muffler Clamps

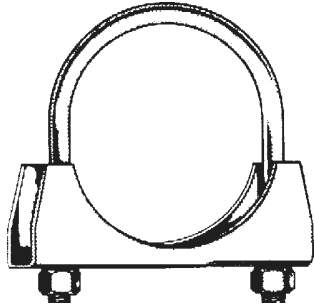

Part No.	Size	Pkg Qty
<b>STANDARD</b> 5/16" dia. U-bolt, standard saddle.		
26-154	1-1/2	12
26-156	2"	12
26-157	2-1/4	12
26-158	2-1/2	12
<b>HEAVY DUTY</b> 3/8" dia. U-bolt, heavy duty saddle.		
26-161	1-3/4	12
26-162	1-7/8	12
26-163	2"	12
26-165	2-1/4	12
26-166	2-1/2	12
26-170	2-3/4	12
26-171	3"	6
26-172	3-1/4	6
26-173	3-1/2	6
26-174	4"	6
26-175	4-1/2	6
26-176	5"	6

# "Positive Seal" Band Clamps

(Flex-Seal Clamps)

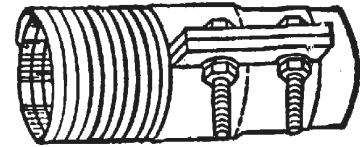
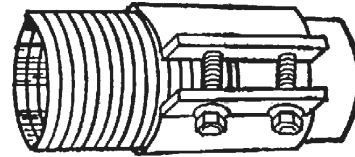

For use on trucks, buses and heavy equipment. Utilize wherever a tight positive seal is needed on tube to tube or different I.D.'s or flexible hose to rigid pipe. Eliminates Saddle Clamps and welding in many cases. If you have noise, exhaust fumes, odor or pollution problems between connecting pipes or tubes, you need Positive Seal Band Clamps. 3" wide stainless steel band. Hardware included.

Part No.	Size	Pkg Qty
26-167	4"	1
26-168	5"	1

# Tail Pipe Hangers

Universal 360° swivels and pivots left or right. Bends to fit most any application. Installs without disassembling muffler clamps. Overall length: 9½". Pkg: 6 each.

Part No. 26-180

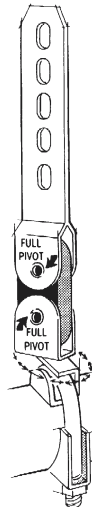

# Perforated Strapping

(Hanger Iron)

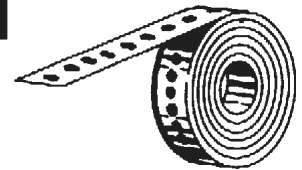

Galvanized malleable steel strapping used for hanging mufflers, fixtures, pipes, drains, conduit, air ducts and more. Comes with 1/4" holes on 1/2" centers.

Part No.	Width	Length	Thick-ness	Pkg Qty
1834	3/4"	10ft.	.035"	10



**CONSTANT QUALITY CONTROL  
GUARANTEES YOUR  
SATISFACTION!**



**MADE IN U.S.A.**

**MAINTENANCE PRODUCTS, INC. USES  
ONLY DOMESTIC MANUFACTURERS  
WHENEVER POSSIBLE.**

**WHEN A DOMESTIC SOURCE IS UNAVAILABLE, ONLY  
IMPORTERS WITH IMPECCABLE REPUTATIONS ARE USED.**

## Poly-Air PVC Air Hose



An excellent choice for pneumatic tools and in-plant use for lightweight and economical applications. In addition to air, this hose may also be used for transfer of water and water soluble chemicals. Temperature range: -15°F to 150°F. Max. working pressure: 300 PSI @70°F, 180 PSI @122°F. Material: seamless PVC tube and cover, with one textile braid and rubber cover. Color: red. *Unlike other hoses, PVC Air Hose assemblies can be made in long continuous lengths due to unique manufacturing process.*

### AIR HOSE ASSEMBLIES

*Brass male pipe thread fittings crimped each end.*

Part No.	Size	Fitting	Pkg
4730-1	1/4 I.D. x 25 ft	1/4 NPT	1
4730-2	1/4 I.D. x 50 ft	1/4 NPT	1
4731-1	3/8 I.D. x 25 ft	1/4 NPT	1
4731-2	3/8 I.D. x 50 ft	1/4 NPT	1
4732-2	1/2 I.D. x 50 ft	3/8 NPT	1

*For bend protectors on each end, add "B" to part number.*

### BULK HOSE (UNCOUPLED)

*Hoses that are cut-to-order not returnable. UPS-able.*

*One continuous length. No random lengths.*

Part No.	I.D.	O.D.	Pkg
4730	1/4	.500	500 ft
4731	3/8	.625	500 ft
4732	1/2	.813	500 ft

## Hose Bend Protectors



Thermoplastic strain reliever supports air, hydraulic and water hoses at the hose end connection, protecting the assembly from damage. Easy to install.



Part Pkg No.	For Hose O.D.	Qty
27-760	.530", .550"	1
27-761	.625"	1
27-762	.688"	1
27-763	.835", .875"	1

## MPT II Multi-Purpose Rubber Air Hose



MPT II is a premium high quality, economical, multi-purpose hose that is oil resistant, excellent for air and water service and many chemicals. Withstands severe abuse, abrasion, and automotive chemicals found in most shops today. This hose may be used for air, grease, oil, gasoline, and low pressure hydraulic service. MPT II hose exceeds RMA Class A - high oil resistance requirements. Reinforcement: Multiple textile spirals. Temperature range: -20°F to +212°F. Max. working pressure: 300 PSI (4:1 safety factor). Material: seamless nitrile tube with one textile braid, smooth neoprene cover. Color: black. *Nonconductive construction has a minimum of one megohm resistance per inch at 1000 volts DC (cover is marked nonconductive).*

### AIR HOSE ASSEMBLIES

*Brass male pipe thread fittings crimped each end.*

Part No.	Size	Fitting	Pkg
4787-1	1/4 I.D. x 25'	1/4 NPT	1
4787-2	1/4 I.D. x 50'	1/4 NPT	1
4788-1	3/8 I.D. x 25'	1/4 NPT	1
4788-2	3/8 I.D. x 50'	1/4 NPT	1
4788-3	3/8 I.D. x 100'	1/4 NPT	1
4789-2	1/2 I.D. x 50'	3/8 NPT	1

*For bend protectors on each end, add "B" to part number.*

### BULK HOSE (UNCOUPLED)

*Cut-to-order lengths not returnable. Full packages shipped on reels.*

Part No.	I.D.	O.D.	Pkg
4787	1/4	.550	500 ft
4788	3/8	.688	500 ft
4789	1/2	.875	500 ft

## Leader Hose Assemblies

*(Also called hose snubbers or hose whips)*

Leader hoses help to prevent coupler failure and coupler nipple breakage at the tool inlet. Made with multi-purpose rubber air hose above.

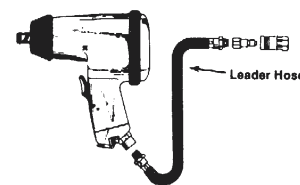

Part No.	Size	Pkg
RIGID COUPLINGS BOTH ENDS - 1/4" NPT MALE		
27-836	1/4 ID x 24"	1
27-837	3/8 ID x 24"	1
360° SWIVEL END, ONE RIGID END - 1/4" NPT MALE		
27-838	1/4 ID x 24"	1
27-839	3/8 ID x 24"	1

*\*Working pressure decreases as temperature increases.*





# Polyurethane Self-Store Hose

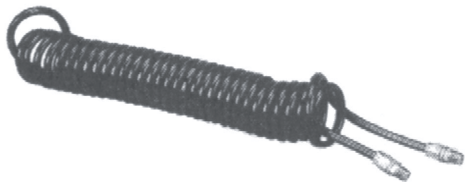

Self-retracting: automatically recoils. Durable and lightweight - 25% lighter than rubber, helps reduce worker fatigue. Extremely flexible - highly resistant to abrasion, wear and kinking. Also offers good heat, oil, ozone and chemical resistance. Recoils to a fraction of its extended length to return pneumatic tool to safe location. Applications: assembly lines and work stations, automotive repair and body shops, transfer of air, fluid and chemicals, car wash soap dispensers. Service temperature range: -40° to 175°F. Max. working pressure†: 125 psi @ 70°F. Working length is 80% of nominal length shown. *Each hose includes 4" pigtail and a 20" whip end. Permanent crimped male swivel pipe fittings both ends.*

Part No.	Hose Size	Working Length	Swivel Pipe	Pkg
4820	1/4 I.D. x 10'	8'	1/4"	1
4821	1/4 I.D. x 15'	12'	1/4"	1
4822	1/4 I.D. x 25'	20'	1/4"	1
4823	1/4 I.D. x 50'	40'	1/4"	1
4824	3/8 I.D. x 25'	20'	1/4"	1
4825	3/8 I.D. x 50'	40'	1/4"	1

†Warning: Working pressure decreases as temperature increases.

# Nylon Coil Air Hose

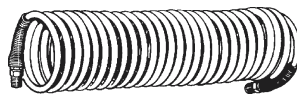

Air hose recoils to a fraction of its extended length to return pneumatic tool to safe location. 1/4" NPT male swivels both ends. Max. working pressure. 200 psi

Part No.	Hose Size	Pkg
4830	1/4 I.D. x 17'	1
4831	1/4 I.D. x 25'	1
4832	1/4 I.D. x 50'	1
4833	3/8 I.D. x 17'	1
4834	3/8 I.D. x 25'	1
4835	3/8 I.D. x 50'	1

# Push-On Low Pressure Hose



## NO CLAMPS REQUIRED!

Our most versatile low pressure hose. *No clamps required when used with push-on hose couplings.* Used for low pressure transmission of air, oil, gasoline, water, coolants, etc. Make quick and easy hose changes in those hard-to-reach areas. Rugged, flame and oil resistant. Lightweight - only 11 lbs/cft. Flexible - easily recoiled after use. Service Temperature Range: -40°F to +212°F. Max. working pressure: 300 PSI. Minimum Burst Pressure: 1200 PSI. Material: Seamless nitrile tube, 1 textile braid†, oil and weather resistant rubber cover.

Also available in bulk on reels.

Part No.	Hose I.D.	Hose O.D.	Working PSI	Burst PSI	Pkg Qty
4700	1/4	.50	300	1200	50'
4701	3/8	.62	300	1200	50'
4702	1/2	.75	300	1200	50'
4703	5/8	.91	300	1200	50'
4704	3/4	1.03	300	1200	50'

† Braid is laid over tube at a special angle which causes hose to tighten around coupling as pressure is applied.

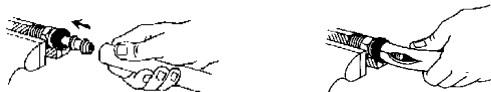

**Assembly:** Lubricate hose and hose end with soap for easy assembly. Push hose on fitting until seated under protective cap.

**Disassembly:** Slit the hose with a knife from protective cap to the end of insert. Bend hose and remove with quick jerk.



# Contractor Grade Air Hose

DAYCO SERIES 7092 GST II

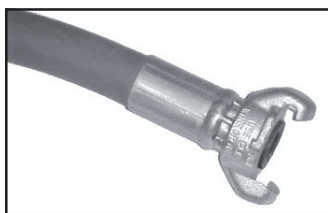

Economical and versatile general service air and water hose. Excellent for contractor air service, jack hammers, and agricultural chemicals including Lasso® herbicide. EPDM tube and

cover resists heat, sunlight, ozone and weathering. Kink resistant multiple textile spiral reinforced. Temperature range: -40°F to +212°F. Maximum working pressure: 200 PSI, 4:1 safety factor.

Part No.	Item	Qty
4790-2	3/4 ID x 50 ft Assembled with 2-lug air couplings assemble each end.	1 roll
4790	Bulk Hose (Uncoupled)	350'

## Low Pressure Hose



### SAE 100R4 HOSE

Seamless oil resistant synthetic rubber tube. Reinforce with one circular woven layer with interwoven helix wire. Oil and weather resistant synthetic rubber cover - MSHA approved. Used for suction or return line on hydraulic systems. Vacuum 25 inches Hg. Temperature range: -40°F to +212°F. SAE/USCG Marine Listed.

Part No.	Hose I.D.	Hose O.D.	Working Press.	Burst Press.	Pkg Qty
D-12C	3/4	1.25	300 psi	1200 psi	25'
D-16C	1"	1.50	250 psi	1000 psi	25'
D-20C	1-1/4	1.77	200 psi	800 psi	25'
D-24C	1-1/2	2.08	150 psi	600 psi	25'
D-32C	2"	2.50	100 psi	400 psi	25'
D-40C	2-1/2	3.13	62 psi	250 psi	25'
D-48C	3"	3.63	56 psi	225 psi	25'

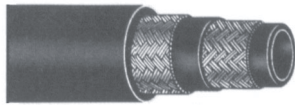

### SAE 30R2 TYPE 2 HOSE

Seamless oil resistant synthetic rubber tube. Reinforce with two textile braids. Oil and weather resistant synthetic rubber cover - MSHA approved. Used for low pressure transmission of oil, gasoline, air and low pressure hydraulic service. Temperature range: -20°F to +180°F.

Part No.	Hose I.D.	Hose O.D.	Working Press.	Burst Press.	Pkg Qty
D-16L2	1"	1.52	300	1200	25'

## DIXON VALVE & COUPLING CO.

For special hard-to-find hoses, fittings & valves, ask MPI for your free Dixon Valve catalog now!

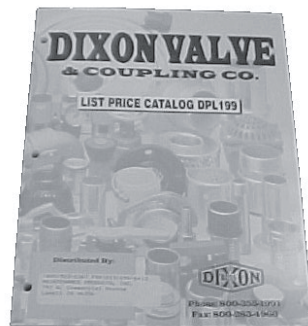

## Dayco SAE 100R1 AT Medium Pressure Hydraulic Hose



### DAYCO-EASTMAN MXX SERIES

Seamless oil resistant tube. One high tensile wire braid. Oil and weather resistant cover. MSHA approved. Used for medium high pressure hydraulic lines on mobile equipment, machine tools, farm .. implements, snow plows and saw mills. No skiving required for fitting assembly. Temperature range: -40°F to +212°F. SAE 100R1 Type AT Thin Cover.

Part No.	Hose I.D.	Hose O.D.	Working PSI	Burst PSI	Pkg Qty
4705	1/4 <sup>(-4)</sup>	.53	2,750	11,000	50'
4706	3/8 <sup>(-6)</sup>	.69	2,250	9,000	50'
4707	1/2 <sup>(-8)</sup>	.81	2,000	8,000	50'
4708	3/4 <sup>(-12)</sup>	1.09	1,250	5,000	25'
4709	1" <sup>(-16)</sup>	1.41	1,000	4,000	25'

Reusable fittings for this hose are available on request.

## Dayco SAE 100R2 AT High Pressure Hydraulic Hose

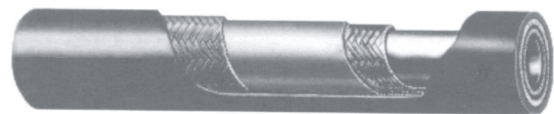

### DAYCO-EASTMAN BXX SERIES

Seamless oil resistant tube two high tensile wire braids. Oil and weather resistant cover. MSHA approved. Used for high pressure hydraulic lines on off-road construction, equipment, machine tools, farm equipment. No skiving required for fitting assembly. Temperature range: -40°F to +212°F. SAE 100R2, Type AT Thin Cover.

Part No.	Hose I.D.	Hose O.D.	Working PSI	Burst PSI	Pkg Qty
4741	1/4 <sup>(-4)</sup>	.59	5,000	20,000	50'
4742	3/8 <sup>(-6)</sup>	.75	4,000	16,000	50'
4743	1/2 <sup>(-8)</sup>	.87	3,500	14,000	50'
4749	5/8 <sup>(-10)</sup>	.95	2,750	11,000	25'
4744	3/4 <sup>(-12)</sup>	1.17	2,250	9,000	25'
4745	1" <sup>(-16)</sup>	1.50	2,000	8,000	25'



## Parker SAE 100R2 AT High Pressure Hydraulic Hose

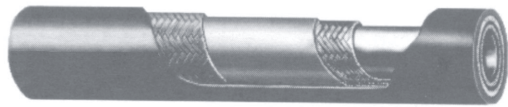

### PARKER 301 SERIES

Seamless oil resistant tube two high tensile wire braids. Oil and weather resistant cover. MSHA approved. Hydraulic fluids, oil, grease, lubricants, crude and fuel oils, air\*, and water. Used for high pressure hydraulic lines on off-road construction, equipment, machine tools, farm equipment. No skiving required for fitting assembly. Temperature range: -40°F to +250°F. SAE 100R2, Type AT Thin Cover.

Part No.	Hose I.D.	Hose O.D.	Working PSI	Burst PSI	Pkg Qty
8241	1/4 <sup>(-4)</sup>	.59	5,000	20,000	50ft
8242	3/8 <sup>(-6)</sup>	.75	4,000	16,000	50ft
8243	1/2 <sup>(-8)</sup>	.87	3,500	14,000	50ft
8244	3/4 <sup>(-12)</sup>	1.17	2,250	9,000	50ft
8245	1" <sup>(-16)</sup>	1.50	2,000	8,000	50ft
8246	1-1/4" <sup>(-20)</sup>	1.89	1,625	4,500	25ft

\*For air & gas applications above 250 psi cover should be pin pricked.

## Contractor's Water Hose



EPDM rubber tube and cover. Spiral reinforced. Heavy duty crush-proof solid brass couplings with wrench grips. Working press. 150 psi. Temp. range: -20°F to 180°F

Part No.	Size	Pkg
17-144	3/4" ID x 50'	1

## Pressure Washer Hose and Assemblies



Working pressure: 3000 PSI. Assemblies have 3/8" male NPT hose ends (one swivel end) and thermoplastic bend protectors. Cover is black.

Part No.	Size	Pkg Qty
<b>ASSEMBLIES</b>		
4786-1	3/8" ID x 30 ft	1
4786-2	3/8" ID x 50 ft	1
4786-4	3/8" ID x 100 ft	1
<b>BULK HOSE (UNCOUPLED)</b>		
4786	3/8" ID	500 ft

More sizes available upon special request

## Welding Hose Assembly



### DAYCO 7126 SERIES - GRADE R

Twin oxygen-acetylene hose assembly has 9/16-18 welding fittings on each end. Cover is vulcanized twin, Red (acetylene) Green (oxygen) EPDM tube and cover. Temperature range: -20°F to +200°F.

Part No.	Size	Pkg Qty
21-299	1/4 ID x 50 ft	1 RL

**The easiest way to get rid of a difficult task is to do it.**

# Air Brake Tubing & Hose



## SAE 100R5 MEDIUM PRESSURE AIR BRAKE & HYDRAULIC HOSE

Commonly call "Aeroquip" hose. Seamless oil resistant tube. One wire braid and one textile braid reinforcement. Impregnated textile braided cover. Oil and mildew resistant. Applications: Used for truck air brakes, medium high pressure hydraulic lines on material handling equipment, off-road equipment, machine tools and other air, water, oil or gasoline service where cover resistance to abrasion is not required. No skiving required for fitting assembly. Temperature range: -40°F to 212°F. SAE 100R5 J1402C, Type AII, D.O.T. FMVSS-106. Made in U.S.A. Pkg: 25 ft.

Part No.	Hose I.D.	Hose O.D.	Working PSI	Burst PSI
4710	3/16 <sup>(-4)</sup>	.52	3,000	12,000
4711	1/4 <sup>(-5)</sup>	.58	3,000	12,000
4712	5/16 <sup>(-6)</sup>	.67	2,250	9,000
4713	13/32 <sup>(-8)</sup>	.77	2,000	8,000
4714	1/2 <sup>(-10)</sup>	.92	1,750	7,000
4715	5/8 <sup>(-12)</sup>	1.08	1,500	6,000

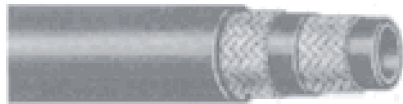

## RUBBER AIR BRAKE HOSE TYPE B

For use on truck and bus compressed air brake systems. Heavy duty neoprene cover resists deterioration from oil, grease and ozone. Smooth S.B.R. inner tube. Can be used with standard air brake replaceable couplings. Manufactured to commonwealth of Pennsylvania specifications and meets S.A.E. J1402 Type B specifications.

Part No.	Hose I.D.	Hose O.D.	Burst Pressure	Pkg Qty
4766	3/8	3/4	1000 psi	50'

**If you need it  
and don't see it  
ASK US!**



## AIR BRAKE HOSE ASSEMBLIES

One male fixed end and one female swivel end with male adapter (brass). Meets S.A.E. J1402 Type B specifications.

Part No.	Hose I.D.	Length	Thrd. Size	Pkg Qty
4826	3/8	24"	1/4 npt	1
4827	3/8	30"	1/4 npt	1
4828	3/8	36"	1/4 npt	1
4829	3/8	48"	1/4 npt	1



SAE J844 Type A



SAE J844 Type B

## NYLON AIR BRAKE TUBING

**SAE J844 Type A - Non Reinforced** Single wall extruded nylon. Sizes 1/8" and 1/4" OD.

**SAE J844 Type B Reinforced** Extruded Nylon inner tube, one layer of open-ply nylon fiber reinforcement and nylon outer cover. Sizes 3/8", 1/2", 5/8", 3/4" OD. Highly resistant to road salt, gasoline & oil, chemicals, cuts and abrasions. Will not fatigue or become brittle. **FITTINGS:** Use of NTA fittings is recommended but can be used with standard compression fittings (with insert support). Temperature range: -40°F to 200°F Not intended for frame to axle or tractor to trailer connections. **Maximum working pressure: 150 PSI**

Part No.	Tube O.D.	Type	Min. Burst Pressure	Wall	Pkg Qty
4760	1/8	A	1000 psi	.023"	100'
4761	1/4	A	1200 psi	.040"	100'
4762	3/8	B	1400 psi	.062"	100'
4763	1/2	B	950 psi	.062"	50'
4764	5/8	B	850 psi	.092"	50'
4765	3/4	B	800 psi	.092"	50'



# Heater Hose and Fuel Line Hose



## HEAVY DUTY TRUCK & BUS HEATER HOSE

Premium quality heavy duty hose designed for service on trucks, buses and other heavy equipment. Special E.P.D.M. rubber tube and cover compound meets demanding service requirements to minimize replacement frequency in truck and bus fleets. Extra strong high tensile reinforcement provides double the working strength of standard heater hose. Manufactured to meet S.A.E. 12D 20R3 Class R Grade 1A. Max. operating temperature: 212°F. Black cover.

Part No.	Hose Size	Burst Pressure	Pkg Qty
31120	5/8 I.D. x 50'	600 psi	1 RL
30718	3/4 I.D. x 50'	600 psi	1 RL
30722	1" I.D. x 50'	400 psi	1 RL



## CRIMSON SHIELD INSULATED HEATER HOSE

This premium heater hose conquers the ozone problem and assures trouble free service. Special 100% E.P.D.M. compound throughout hose. Top quality Ethylene-Propylene rubber. Resists ozone, antifreeze, temperature extremes, abrasion swelling, softening and flaking. Superior insulating quality. Delivers more heat for improved heater efficiency. Meets SAE 20R3 Class D2. Max. operating temperature: 212°F. Red cover.

Part No.	Hose Size	Burst Pressure	Pkg Qty
4768	1/2" I.D. x 50'	250 psi	1 RL
4769	5/8" I.D. x 50'	250 psi	1 RL
4770	3/4" I.D. x 50'	200 psi	1 RL

**Red Hot Deals!**

Check out our current specials and new items on our website at <http://www.mpi-online.com>



## SILICONE HEATER HOSE

Built for lasting performance at -65° F to 400°F operating temperatures. Resistant to ozone, chemicals and lubricants. Exceeds SAE J20E.3 and TMC performance requirements. Red silicone tube and blue cover.

*Note: Always use "Lined Hose Clamps" with Silicone Heater Hose. **Warning:** Do not use serrated, slotted, or wire type clamps with this hose.*

Part No.	Hose Size	Burst Pressure	Pkg Qty
4750	1/2" I.D. x 25'	310 psi	1 RL
4751	5/8" I.D. x 25'	300 psi	1 RL
4752	3/4" I.D. x 25'	300 psi	1 RL

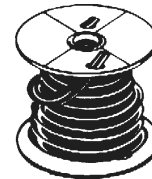

## HYPALON FUEL LINE & VAPOR EMISSION HOSE

Nitrile tube resistant to deterioration effects of gasoline, diesel, leaded, unleaded, ethanol, and methanol based fuels. Excellent where petroleum vapors and blow by gases are recirculated through intake manifold. Hypalon cover provides maximum heat resistance up to 257° F and meets O.E.M. specifications. Meets or exceeds SAE J30R6, SAE 130R7, GM 6165M specifications.

Part No.	Hose Size	Pkg Qty
25048	3/16" I.D. x 25'	1 RL
4775	1/4" I.D. x 25'	1 RL
4776	5/16" I.D. x 25'	1 RL
4777	3/8" I.D. x 25'	1 RL

## WINDSHIELD WASHER VACUUM TUBING

Meets SAE J200 BA710 specifications.

Part No.	Hose Size	Use Barb Fitting	Pkg Qty
4778	7/64" I.D. x 50'	1/8"	1 RL
4779	5/32" I.D. x 50'	3/16"	1 RL
4780	7/32" I.D. x 50'	1/4"	1 RL
3342	9/32" I.D. x 50'	5/16"	1 RL



# Tubing



## POLYETHYLENE TUBING

Chemically resistant, flexible and lightweight. Designed for FDA applications. Low density. Natural off-white in color. Operating temperature: -50°F to +125°F. Use with poly-tite and brass compression fittings (with insert for support).

Part No.	O.D.	I.D.	Pressure		Pkg Qty
			Working	Burst	
2714	5/32"	7/64"	150	800	100'
2715	1/4	11/64"	135	625	100'
2717	5/16	3/16"	135	800	100'
2719	3/8	1/4"	120	672	100'
2721	1/2	3/8"	90	425	100'
2723	5/8	1/2"	70	325	100'



## COPPER TUBING

Soft, annealed seamless copper. 50 feet per roll.

Part No.	Size O.D.	Wall Gauge	Pressure		Pkg Qty
			Working	Burst	
2700	1/8	.030	1200	3130	1 RL
2701	3/16	.030	1990	8000	1 RL
2702	1/4	.030	1450	5000	1 RL
2703	5/16	.032	1230	4000	1 RL
2704	3/8	.032	1010	3000	1 RL
2705	1/2	.032	740	2000	1 RL
2706	5/8	.035	640	1800	1 RL
2707	3/4	.035	520	1500	1 RL

*Heavy duty annealed copper tubing available on special request*



## CLEAR VINYL TUBING

Nonreinforced, clear tubing for visible fluid flow. Soft for easy handling and bending. • Nontoxic food and beverage grade. FDA & USDA accepted, NSF certified. Use with Multi-Barb or Compression Fittings (with insert for support)

Part No.	O.D.	I.D.	Working PSI @70°F	Pkg Qty
2738	5/16	3/16	55	100'
2740	3/8	1/4	55	100'
2742	1/2	3/8	45	100'
2744	5/8	1/2	30	100'
2746	3/4	1/2	45	100'
2749	7/8	5/8	40	50'
2751	1"	3/4	35	50'



## DOUBLE WALL STEEL TUBING

Automotive grade. Constructed of the same material as standard brake lines. Tin coated. Bends and flares easily. Wall thickness: .028". 25 feet per roll.

Part No.	Size O.D.	Pkg
15-114	3/16	1 RL
15-115	1/4	1 RL
15-116	5/16	1 RL
15-117	3/8	1 RL

## DELUXE HOSE CUTTER



Length is 9 3/4" for extra leverage. Razor sharp blade cuts plastic and vinyl tubing and non-wire reinforced hose up to 1-1/8" OD. All metal construction. Comfortable PVC coated handles. Made in Canada. **Part No. 10-393**

*Replacement Blades for above: Part No. 10-394*

## TUBING CUTTER

Razor sharp blade cuts plastic and vinyl tubing and non-wire reinforced hose up to 9/16" OD. **Part No. 23-317**

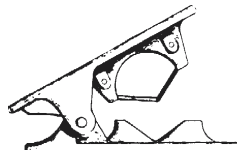

# Steel Hydraulic Brake Lines



Double wall, copper fused, double flared, and tin coated. Annealed for easy bending. Resists kinking.

TUBE SIZE	8"	12"	20"	30"	40"	51"	60"	Pkg
3/16"	99-190	99-192	99-196	99-200	99-206	99-211	99-215	10
1/4"	99-191	99-193	99-197	99-201	99-207	99-212	99-216	10
5/16"	-	99-194	99-198	99-202	99-208	99-213	99-217	5
3/8"	-	99-195	99-199	99-203	99-209	99-214	99-218	5

## Tubing Clamps

### Nylon Closed Clips



Chemical and shock resistant nylon clip for wire loom, hoses or cables. Nonconductive. Width: 3/8"

Part Number	Inside Diameter	Bolt Hole	Pkg Qty
1641	1/4"	#8	25
1642	5/16"	#8	25
1643	3/8"	#8	25
1644	1/2"	#8	25
1645	5/8"	#10	25
1646	3/4"	#10	25
1647	1"	#10	25

### Insulated Closed Clips



Plated steel with Vinyl coating

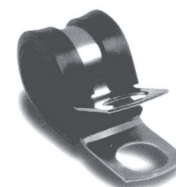

**NEW ITEM!**  
Aluminum with neoprene rubber cushion

Used to fasten wire loom, hose, tubing and cable. Furnished open. Temperature and oil resistant.

Size Closed I.D.	STEEL w/Vinyl Dipped	ALUMINUM w/Neoprene Cushion	Pkg Qty
<b>1/2" WIDE, 1/4" BOLT HOLE</b>			
1/4"	1601	02-440	25
5/16"	1602	02-441	25
3/8"	1603	02-442	25
1/2"	1604	02-443	25
5/8"	1605	02-444	25
3/4"	1606	02-445	25
7/8"	1607	02-446	25
1"	1608	02-447	25
<b>3/4" WIDE, 3/8" BOLT HOLE</b>			
1/4"	1609	-	25
5/16"	1610	-	25
3/8"	1611	-	25
1/2"	1612	-	25
5/8"	1613	-	25
3/4"	1614	-	25
7/8"	1615	-	25
1"	1616	-	25
1-1/4"	1617	-	25
1-1/2"	1618	-	25

### Adhesive Backed Nylon Tubing Clamps

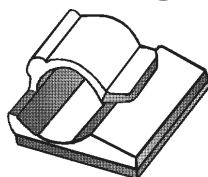

Secures wiring, hose and tubing to most surfaces. Locks securely, opens easily. Use at temperatures to 180°F.

Part No.	Tubing Diameter	Pkg Qty
1648	5/32" to 1/4" O.D.	25
1649	5/16" to 1/2" O.D.	25
1650	9/16" to 3/4" O.D.	25

# Hose Clamps

## ENGINEERED FOR TOUGH INSTALLATIONS

- ROUNDED EDGES TO PROTECT THE HOSE
- EFFICIENT 3-PIECE CONSTRUCTION
- NO SPOT WELDS TO CORRODE
- EASILY INSTALLED WITH SCREWDRIVER, NUT DRIVER OR SOCKET WRENCH
- SCREWS FEATURE DEEP SLOTS FOR QUICK INSTALLATION
- MEETS OR EXCEEDS SAE TORQUE SPECIFICATIONS

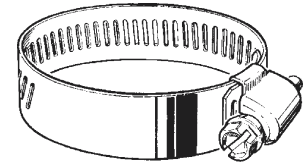

**100% INTERLOCK CONSTRUCTION FEATURES**

One piece housing which directly locks into the band. Spot weld free design.

## FOUR STYLES FOR EVERY APPLICATION!

### PARTIAL STAINLESS

Most common clamp for automotive and industrial applications. Combines economy with durability. 1/2" wide stainless steel band. Plated steel 5/16" slotted hex head screw and housing.

### ALL STAINLESS STEEL

All stainless steel for good corrosion resistance and extra strength. 1/2" wide, 300 series stainless steel band and housing. 400 series stainless steel (magnetic) 5/16" slotted hex head screw.

### LOW-MAG 300 SERIES STAINLESS STEEL

High quality stainless steel with low magnetic permeability and high corrosion resistance. Well suited for marine applications, swimming pools, or anywhere humidity is a problem. 1/2" wide, 300 series stainless steel band, 300 series stainless steel housing and 5/16" slotted hex head screw.

### LINED HOSE CLAMPS

Recommended for use with soft hoses like silicone heater hose. Provides maximum protection for all soft hoses while ensuring a strong, positive seal. 1/2" wide band, liner and housing are made from stainless steel. Plated steel 5/16" slotted hex head screw. Inner liner covers band serrations which prevents hose damage.

For order information see next page

## Hose Clamp Assortments

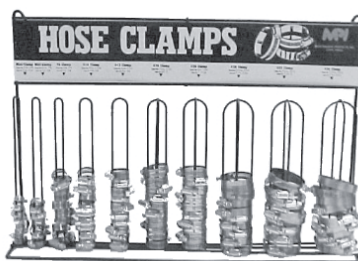

### "PARTIAL STAINLESS" HOSE CLAMP ASSORTMENT

Sizes 4 and 6 miniature, 8, 10, 12, 16, 20, 28, 32, and 36 standard clamps in a metal hose clamp rack. **Part No. 2396**

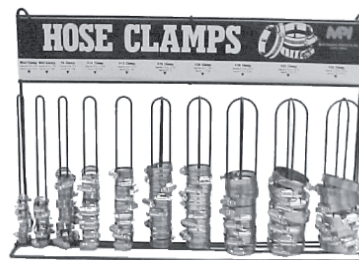

### "ALL STAINLESS" HOSE CLAMP ASSORTMENT

Sizes 4 and 6 miniature, 8, 10, 12, 16, 20, 28, 32, and 36 "all stainless steel" clamps in a metal hose clamp rack. **Part No. 2397**

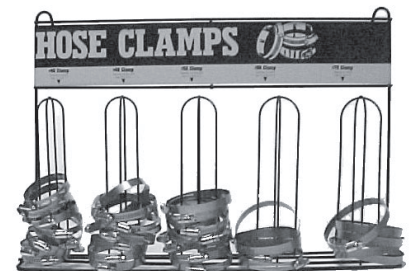

### "PARTIAL STAINLESS" BIG HOSE CLAMP ASSORTMENT

Sizes 40, 48, 52, 56 and 72 standard clamps in a metal hose clamp rack. **Part No. 2394**

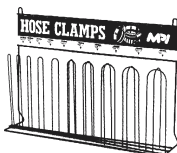

### HOSE CLAMP RACK

Heavy wire rack holds 10 sizes from 4 to 36. **Part No. 2398**

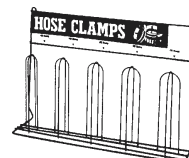

### BIG HOSE CLAMP RACK

Heavy wire rack holds 5 sizes from 40 to 72. **Part No. 2395**



# Hose Clamps

SAE SIZE**	PARTIAL STAINLESS	ALL STAINLESS	LOW-MAG STAINLESS	PKG QTY
<b>5/16" BAND WIDTH</b>				
4 (Mini)	1577	2500	-	25
6	2401	2501	-	25
8	2402	2502	-	25
10	2403	-	-	25
12	2404	-	-	25
<b>1/2" BAND WIDTH</b>				
6	1578	2405	2505	25
8	1579	2406	2506	25
10	1580	2407	2507	25
12	1581	2408	2508	25
16	1582	2409	2509	25
20	1583	2410	2510	25
24	1584	2411	2511	25
28	1585	2412	2512	25
32	1586	2413	2513	25
36	1587	2414	2514	25
40	1588	2415	2515	25
44	1589	2416	2516	25
48	1590	2417	2517	10
52	1591	2418	2518	10
56	1592	2419	2519	10
60	1593	-	-	10
64	1594	2420	2520	10
72	1595	2423	2523	10
80	1596	2424	2524	10
88	1597	2425	2525	10
96	1598	2426	2526	10
104	1599	2427	2527	10
116	-	2428	2528	10



**LINED HOSE CLAMPS**      **PKG QTY**

2530	10
2531	10
2532	10
2533	10
2534	10
2535	10
2536	10
2537	10
2538	10
2539	10
2540	10
2541	10
2542	10
2543	10
2544	10
2545	10
2546	10
2547	10

## HOSE CLAMP DIMENSIONS

SIZE**	STD. HOSE CLAMP DIAMETER		HOSE I.D. RANGE*		LINED HOSE CLAMP DIAMETER		SAE
	MIN.	MAX.	MIN.	MAX.	MIN.	MAX.	
4	7/32	5/8	3/16	5/16	-	-	-
6	3/8	7/8	1/4	3/8	5/8	3/4	-
8	7/16	1"	5/16	1/2	5/8	13/16	3/4
10	9/16	1-1/16	3/8	5/8	3/4	15/16	1-1/8
12	9/16	1-1/4	5/8	3/4	3/4	1-1/8	1-1/8
16	11/16	1-1/2	3/4	1"	13/16	1-3/8	1-3/8
20	3/4	1-3/4	1"	1-1/4	1-1/8	1-5/8	1-5/8
24	1-1/16	2"	1-1/4	1-1/2	1-3/16	1-15/16	1-15/16
28	1-5/16	2-1/4	1-1/4	1-3/4	1-5/16	2-1/4	2-1/4
32	1-9/16	2-1/2	1-1/2	2"	1-9/16	2-1/2	2-1/2
36	1-13/16	2-3/4	1-3/4	2-1/4	1-13/16	2-3/4	2-3/4
40	2-1/16	3"	2"	2-1/2	2-1/16	3"	3"
44	2-5/16	3-1/4	2-1/4	2-3/4	2-5/16	3-1/4	3-1/4
48	2-9/16	3-1/2	2-1/2	3	2-9/16	3-1/2	3-1/2
52	2-13/16	3-3/4	3"	3-1/4	2-13/16	3-3/4	3-3/4
56	3-1/16	4"	3-1/4	3-1/2	3-1/16	4"	4"
60	3-5/16	4-1/4	3-1/2	3-3/4	3-5/16	4-1/4	4-1/4
64	3-9/16	4-1/2	3-1/2	4	3-9/16	4-1/2	4-1/2
72	4-1/16	5"	3-3/4	4-1/2	4-1/16	5"	5"
80	4-5/8	5-1/2	4"	5	-	-	-
88	4-3/32	6"	4"	5-1/2	-	-	-
96	4-1/2	6-1/2	5"	6"	-	-	-
104	5"	7"	5"	6-1/2	-	-	-
116	5-3/4	7-3/4	-	-	-	-	-

\* Hose I.D. Range for all clamps excluding "Lined" Hose Clamps through size #24. Hose size is inside diameter assuming a 3/16" hose wall thickness.

\*\* SAE sizes correspond to hose number. Example: A #8 hose clamp will fit #8, 1/2" I.D. hose (8/16ths = 1/2")

# FITTING MEASUREMENT

## TUBE SIZES

All tube sizes referred to in this catalog pertain to the outside diameter of the tubing with exceptions noted where appropriate. The tube size of the fitting can be determined by one of the following methods, whichever is appropriate:

1. If the nut or sleeve (ferrule) can be measured, determine what part of the fitting the tubing is inserted by examining the assembly illustrations on the following pages and measure the unthreaded inside diameter with a caliper or ruler. Diameter "A" would be the tube size.



2. If only the body of the fitting is available (on compression style fittings) then with your caliper or ruler, measure the inside diameter of the tube insertion point. Diameter "B" would be the tube size. (This method may not be suitable for compression fittings using a rubber ring as the sealing sleeve and some plastic one-piece nut and sleeve combinations.)

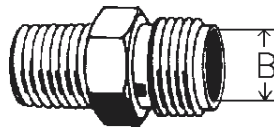

3. Referring to the tube size charts below, measure the thread diameter with a caliper and determine the threads per inch either with a thread pitch gauge or by counting (from crest to crest) the number of threads in one quarter inch and multiply by four. For example, 4 full threads in one quarter inch, would equal sixteen threads per inch. Finding the proper style in the chart, choose the tube thread diameter and thread pitch to determine the tube size.

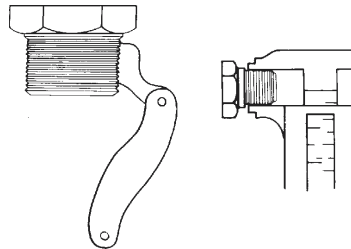

## TUBE END THREAD SIZES

O.D. TUBE SIZE	1/8	3/16	1/4	5/16	3/8	7/16	1/2	5/8	3/4	7/8	1"	1-1/4	1-1/2	2"
DASH NUMBER	-2	-3	-4	-5	-6	-7	-8	-10	-12	-14	-16	-20	-24	-32
STD. COMPRESSION	5/16-24	3/8-24	7/16-24	1/2-24	9/16-24	5/8-24	11/16-20	13/16-18	1-18	1-1/8-18	1-1/4-18			
AIR BRAKE (Copper)			7/16-24		17/32-24		11/16-20	13/16-18	1-18					
NTA AIR BRAKE			7/16-24		17/32-24		11/16-20	13/16-18	1-18					
POLY-TITE	5/16-24	3/8-24	3/8-24	7/16-24	1/2-24		11/16-20							
DOUBLE COMPRESSION	5/16-24	3/8-24	7/16-24	1/2-20	9/16-20	5/8-18								
SAE 45° FLARE	5/16-24	3/8-24	7/16-20	1/2-20	5/8-18	11/16-16	3/4-16	7/8-14	1-1/16-14					
JIC 37° FLARE	5/16-24	3/8-24	7/16-20	1/2-20	9/16-18		3/4-16	7/8-14	1-1/16-12	1-3/16-12	1-5/16-12	1-5/8-12	1-7/8-12	2-1/2-12
INVERTED FLARE	5/16-28	3/8-24	7/16-24	1/2-20	5/8-18	11/16-18	3/4-18	7/8-18	1-1/16-16	1-3/16-16	1-5/16-16			
O-RING BOSS	5/16-24	3/8-24	7/16-20	1/2-20	9/16-18		3/4-16	7/8-14	1-1/16-12	1-3/16-12	1-5/16-12	1-5/8-12	1-7/8-12	2-1/2-12



# FITTING MEASUREMENT

## TUBE SIZES

4. The illustrations below show actual tubing outside diameters. To determine tube size compare a cross-section of the tubing, the inside diameter of the sleeve (ferrule), or place the unthreaded end of the nut over the closest size.

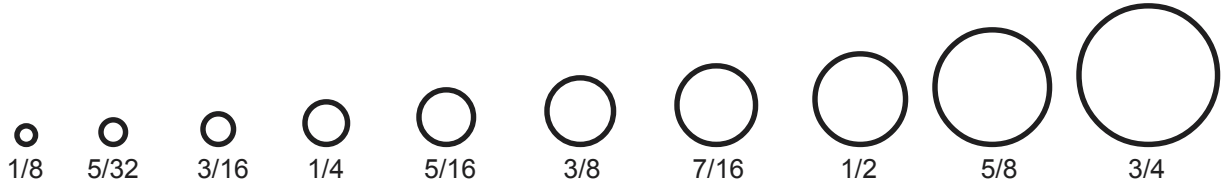

### Standard Compression Fittings

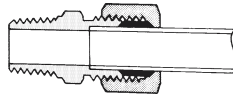

This type of fitting was designed as an easy and economical method of connecting tubing with the assurance of a tight joint that can be repeatedly disconnected and connected without leakage. By using Compression Fittings, flaring and soldering are eliminated.

Compression Fitting connections are made by slipping the nut and sleeve over the tubing and inserting the tubing into the fitting. The nut is then tightened onto the fitting and the action of turning the nut compresses the sleeve and makes the sleeve a component part of the tubing. The angle of the compressed sleeve makes a leakproof joint between the tubing and the fitting. Compression fittings are sold complete with nuts and sleeves.

### Double Compression Fittings

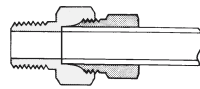

Called Double Compression because of the "double" duty of the threaded sleeve, both nut and compression sleeve, these fittings are used primarily on low and medium pressure work. The two-piece assembly of a compression type fitting has two main advantages. The nut is tightened inside of the fitting making a compact assembly and fewer component parts make assembly simplified. Double Compression Fittings are sold less the nuts.

### Air Brake Compression Fittings (for Copper Tubing)

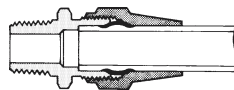

The same sealing principle as a Standard Compression Fitting, but the addition of a long nut and spherical sleeve provide the vibration resistance necessary for heavy duty truck and tractor equipment. Meets all D.O.T and SAE specifications..

Air Brake Fittings can be differentiated from standard compression fittings by the "AIR BRAKE", "AB" or "D.O.T." letters on the wrench flats.

They come complete with nut and sleeve. The addition of the proper tube insert easily and legally converts the fitting for use with nylon air brake tubing.

# FITTING MEASUREMENT

## NTA Air Brake Fittings (for Nylon Tubing)

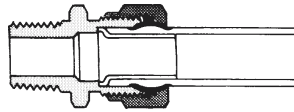

Utilizing the compression sleeve principle, NTA (Nylon Tube, Air brake) Fittings provide a D.O.T. approved connection when used with NTA tubing. The body of the fitting contains a staked-in stainless tube insert to prevent tube restriction when the nut is tightened. While these fittings may be used with any plastic tubing, care should be taken that the I.D. of the tubing matches the insert's outside diameter. Use of standard air brake nylon tubing, which matches perfectly, is recommended and makes the only D.O.T approved connection. Sold complete with nuts, sleeves and inserts.

## Flare Fittings (45° SAE)

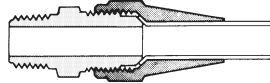

Flared tube Fitting connections are made by slipping the nut over the tubing and flaring the end of the tubing by use of a flaring tool. When used with rubber hose connections, the swivel nut of the hose end provides a simple and reliable connection for air, fuel and hydraulic lines. The nut is pulled up with a wrench, and a tight joint is obtained by sandwiching the flared tubing between the mating flare surfaces. The connection can be disconnected and connected frequently. These fittings can be used on low, medium and high pressure lines under the most adverse conditions. All Flare Fittings are sold less the nuts.

## Inverted Flare Fittings

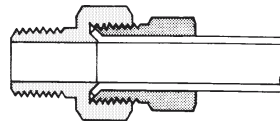

This type of fitting is similar to the Flare Fitting except that the flare seat is inside of the body. The nut is tightened inside of the fitting making the assembly very compact. These fittings can be used on low, medium, and high pressure work and are sold less the nuts. Most commonly used in the automotive industry where it is popular for fuel and hydraulic brake line assemblies.

## Poly-Tite Fittings

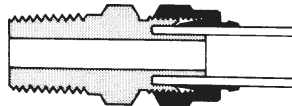

A compact brass compression type fitting designed to speed and simplify plastic tubing installations. The brass nut and plastic sleeve (brass sleeve supplied on 1/8 and 3/16 sizes) are pre-assembled. The tube support is built into the fitting body on tube sizes larger than 3/16 so there is no fumbling around looking for lost components. Use with polyethylene, polypropylene and nylon tubing for instrumentation, air, water, lubrication, fuel and coolant lines. (Be sure the built-in insert's O.D. matches the tubing's I.D.) A complete seal is obtained by hand tightening the nut though most mechanics feel a wrench tight fit is more realistic.

## Push-In Fittings

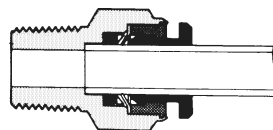

The simplicity of the Push-in Fitting is its primary advantage. Simply cut the tubing square and push the tubing into the fitting. The o-ring seal will hold pressures up to that of the tubing. A push on the collar releases the grip and the fitting never has to be unscrewed for new tubing to be inserted. A supply of unions and tubing in a truck cab will make emergency tubing repairs quick and simple.

# FITTING MEASUREMENT

**Pipe Thread Sealing Tips** 1. Always use some type of sealant (tape or paste) and apply sealant to male thread only. If using a hydraulic sealant, allow sufficient curing time before system is pressurized. 2. When using tape sealant, wrap the threads in a clockwise motion starting at the first thread and, as layers are applied, work towards the imperfect (vanishing) thread. If the system that the connection being made to cannot tolerate foreign matter (i.e. air systems), leave the first thread exposed and apply the tape sealant as outlined above. 3. When using teflon paste sealant, apply to threads with a brush, using the brush to work the sealant into the threads. Apply enough sealant to fill in all the threads all the way around. 4. For sizes 2" and below, tape or teflon paste performs satisfactory. When using thread tape, four wraps (covering all necessary threads) is usually sufficient. 5. For sizes 2-1/2" and above, teflon paste is recommended. If thread tape is used, eight wraps (covering all necessary threads) is usually sufficient. Apply more wraps if necessary. 6. For stubborn to seal threads, apply a normal coating of teflon paste followed by a normal layer of thread tape. 7. Over-tightening threads can be just as detrimental as insufficient tightening. For sizes 2" and below, hand tighten the components and, with a wrench, tighten 3 full turns. For sizes 2 1/2" and above, hand tighten the components and, with a wrench, tighten 2 full turns.

## Male Pipe Thread Sizes

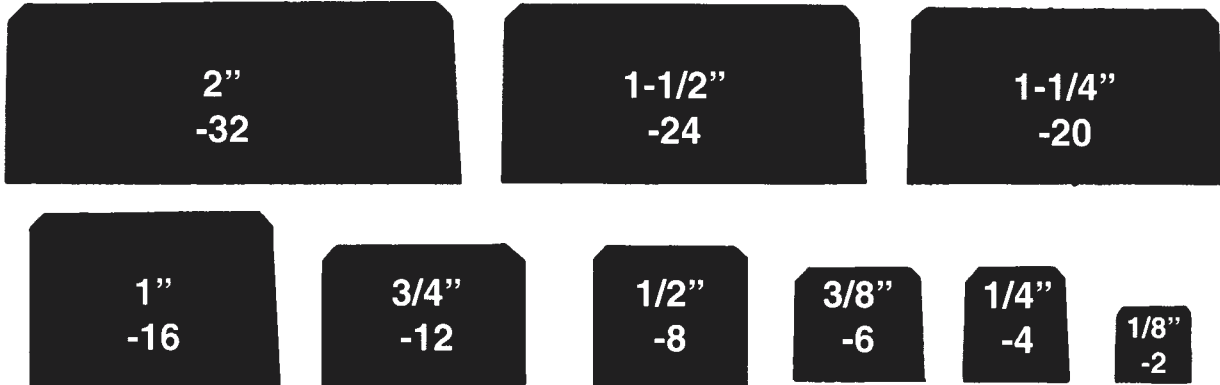

## SAE (JIC) 37° Flare Nose Cone Sizes

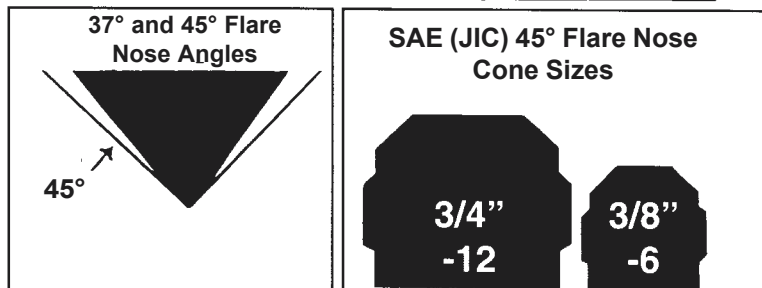
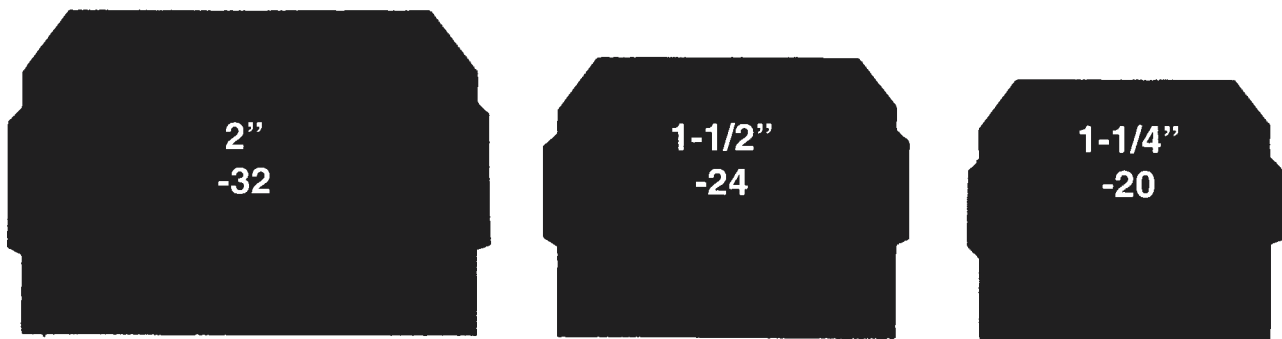



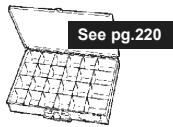

# Standard Brass Compression Fitting



## COMPRESSION SLEEVE

(Ferrules)

Part No.	Tube Size	Pkg Qty
27-001	1/8	100
27-002	3/16	100
27-003	1/4	100
27-004	5/16	100
27-005	3/8	100
27-006	7/16	100
27-007	1/2	50
27-008	5/8	25
27-009	3/4	25

Parker 60C, Weatherhead 60, Edelmann 160, Imperial Eastman 60-F



## COMPRESSION NUT

Part No.	Tube Size	Pkg Qty
27-010	1/8	25
27-011	3/16	25
27-012	1/4	25
27-013	5/16	25
27-014	3/8	25
27-015	1/2	10
27-016	5/8	10
27-017	3/4	5

Parker 61C, Weatherhead 60, Edelmann 160, Imperial Eastman 60-F



## DELRIN SLEEVES

(PLASTIC)

Delrin Sleeves replace brass sleeves to convert Standard Compression Fittings for use with plastic tubing. A brass Tube Insert (below) completes the assembly.

PART No.	Tube Size	Pkg Qty
27-515	1/4	100
27-516	5/16	100
27-517	3/8	100
27-518	1/2	100



## COMPRESSION LONG NUT

Used for extra support where excessive vibration may be encountered. NOT FOR AIR BRAKE USE.

Part No.	Tube Size	Pkg Qty
27-018	3/16	25
27-019	1/4	25
27-020	5/16	25
27-021	3/8	25
27-022	1/2	10
27-023	5/8	10
27-024	3/4	5

Parker 61CL, Weatherhead 1611, Imperial Eastman 161-F



## TUBE INSERTS

(FOR PLASTIC TUBING)

Used inside plastic tubing to keep it from collapsing. Also see "Nylon Truck Airbrake Inserts".

Part No.	Tube Size	Insert O.D.	Pkg Qty
27-842	1/8	.080	25
27-843	1/8	.074	25
27-844	3/16	.095	25
27-845	3/16	.110	25
27-846	3/16	.135	25
27-847	1/4	.125	25
27-510	1/4	.163	25
27-511	5/16	.187	25
27-848	5/16	.215	25
27-512	3/8	.245	25
27-513	1/2	.370	10
27-514	5/8	.483	10

Parker 63PT, Weatherhead 74,



## COMPRESSION UNION

Tube to Tube

Part No.	Tube Size	Pkg Qty
27-025	1/8	10
27-026	3/16	10
27-027	1/4	10
27-028	5/16	10
27-029	3/8	10
27-030	1/2	5
27-031	5/8	5
27-032	3/4	5

Parker 62C, Weatherhead 62, Edelmann 162, Imperial Eastman 62-F

Save when you buy in quantity!



# Standard Brass Compression Fittings

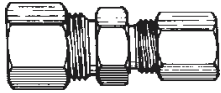

## COMPRESSION REDUCING UNION

*Tube to Tube*

Part No.	Tube Size	Tube Size	Pkg Qty
27-849	1/4	1/8	10
27-850	1/4	3/16	10
27-851	5/16	1/4	10
27-852	3/8	1/4	10
27-853	3/8	5/16	10
27-854	1/2	3/8	5

Parker 62C

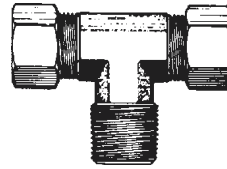

## COMPRESSION BRANCH TEE

*Tube to Male Pipe*

Part No.	Tube Size	Pipe Size	Pkg Qty
27-140	3/16	1/8	5
27-141	1/4	1/8	5
27-142	1/4	1/4	5
27-143	5/16	1/8	5
27-144	5/16	1/4	5
27-145	3/8	1/8	5
27-146	3/8	1/4	5
27-147	3/8	3/8	5
27-148	1/2	3/8	5

Parker 172C, Weatherhead 72, Edelmann 172, Imperial Eastman 72-F

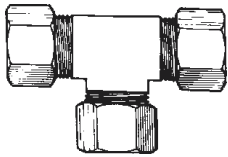

## COMPRESSION UNION TEE

*Tube to Tube to Tube*

Part No.	Tube Size	Pkg Qty
27-036	1/8	5
27-037	3/16	5
27-038	1/4	5
27-039	5/16	5
27-040	3/8	5
27-041	1/2	5
27-042	5/8	5
27-043	3/4	5

Parker 164C, Weatherhead 64, Edelmann 164, Imperial Eastman 64-F

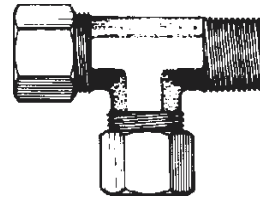

## COMPRESSION MALE RUN TEE

*Tube to Male Pipe*

Part No.	Tube Size	Pipe Size	Pkg Qty
27-626	3/16	1/8	5
27-138	1/4	1/8	5
27-139	1/4	1/4	5
27-627	5/16	1/8	5
27-628	5/16	1/4	5
27-629	3/8	1/4	5
27-630	3/8	3/8	5
27-631	1/2	3/8	5
27-632	1/2	1/2	5

Parker 171C, Weatherhead 71, Edelmann 171, Imperial Eastman 71-F

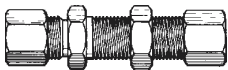

## COMPRESSION BULKHEAD UNION

*Tube to Tube*

PART No.	Tube Size	Pkg Qty
27-033	1/4	5
27-034	3/8	5
27-035	1/2	5

Parker 62CBH, Weatherhead 74

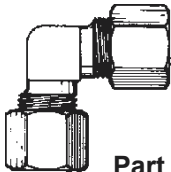

## COMPRESSION UNION ELBOW

*Tube to Tube*

Part No.	Tube Size	Pkg Qty
27-044	1/8	5
27-045	3/16	5
27-046	1/4	5
27-048	3/8	5
27-049	1/2	5
27-050	5/8	5
27-051	3/4	5

Parker 165C, Weatherhead 65, Edelmann 165, Imperial Eastman 65-F

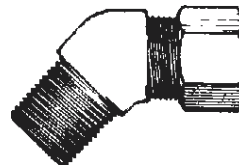

## COMPRESSION 45° MALE ELBOW

*Tube to Male Pipe*

Part No.	Tube Size	Pipe Size	Pkg Qty
27-646	1/4	1/8	10
27-122	5/16	1/4	10
27-647	3/8	1/4	10
27-648	1/2	3/8	5
27-123	5/8	1/2	5

Parker 179C, Imperial Eastman 74-F

# Standard Brass Compression Fittings

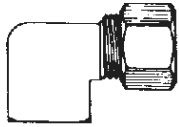

**COMPRESSION  
90° FEMALE ELBOW**  
*Tube to Female Pipe*

Part No.	Tube Size	Pipe Size	Pkg Qty
27-124	1/8	1/8	5
27-125	3/16	1/8	5
27-126	1/4	1/8	5
27-127	1/4	1/4	5
27-128	5/16	1/8	5
27-129	5/16	1/4	5
27-130	3/8	1/4	5
27-131	3/8	3/8	5
27-132	3/8	1/2	5
27-133	1/2	1/4	5
27-134	1/2	3/8	5
27-135	1/2	1/2	5
27-136	5/8	1/2	5
27-137	5/8	3/4	5

Parker170C, Weatherhead 70, Edelmann 170, Imperial Eastman 70-F

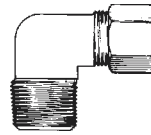

**COMPRESSION  
90° MALE ELBOW**  
*Tube to Male Pipe*

Part No.	Tube Size	Pipe Size	Pkg Qty
27-099	1/8	1/8	10
27-100	3/16	1/8	10
27-101	3/16	1/4	10
27-102	1/4	1/8	10
27-103	1/4	1/4	10
27-104	1/4	3/8	5
27-105	1/4	1/2	5
27-106	5/16	1/8	10
27-107	5/16	1/4	10
27-108	5/16	3/8	5
27-109	3/8	1/8	5
27-110	3/8	1/4	10
27-111	3/8	3/8	10
27-112	3/8	1/2	5
27-113	3/8	3/4	5
27-114	1/2	1/4	5
27-115	1/2	3/8	5
27-116	1/2	1/2	5
27-118	5/8	1/2	5
27-119	5/8	3/4	5
27-120	3/4	1/2	5
27-121	3/4	3/4	5

Parker 169C, Weatherhead 69, Edelmann 169, Imperial Eastman 69-F

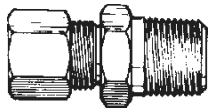

**COMPRESSION  
MALE CONNECTOR**  
*Tube to Male Pipe*

Part No.	Tube Size	Pipe Size	Pkg Qty
27-075	1/8	1/8	10
27-076	3/16	1/8	10
27-077	3/16	1/4	10
27-078	1/4	1/8	10
27-079	1/4	1/4	10
27-080	1/4	3/8	10
27-081	1/4	1/2	10
27-082	5/16	1/8	10
27-083	5/16	1/4	10
27-084	5/16	3/8	10
27-085	3/8	1/8	10
27-086	3/8	1/4	10
27-087	3/8	3/8	10
27-088	3/8	1/2	10
27-089	3/8	3/4	5
27-090	1/2	1/4	5
27-091	1/2	3/8	5
27-092	1/2	1/2	5
27-093	1/2	3/4	5
27-094	5/8	3/8	5
27-095	5/8	1/2	5
27-096	5/8	3/4	5
27-097	3/4	1/2	5
27-098	3/4	3/4	5

Parker 68C, Weatherhead 68, Edelmann 168, Imperial Eastman 68-F



**COMPRESSION  
FEMALE CONNECTOR**  
*Tube to Female Pipe*

Part No.	Tube Size	Pipe Size	Pkg Qty
27-052	1/8	1/8	10
27-053	3/16	1/8	10
27-054	3/16	1/4	10
27-055	1/4	1/8	10
27-056	1/4	1/4	10
27-057	1/4	3/8	5
27-058	1/4	1/2	5
27-059	5/16	1/8	10
27-060	5/16	1/4	10
27-061	5/16	3/8	5
27-062	3/8	1/8	10
27-063	3/8	1/4	10
27-064	3/8	3/8	10
27-065	3/8	1/2	10
27-066	3/8	3/4	5
27-067	1/2	1/4	5
27-068	1/2	3/8	5
27-069	1/2	1/2	5

Parker 66C, Weatherhead 66, Edelmann 166, Imperial Eastman 66-F



# Standard Compression Fitting Assortments



**BRASS COMPRESSION FITTING ASSORTMENT**  
32 SIZES, 1/8" - 3/8" OD TUBING SIZE, IN  
A LARGE STEEL DRAWER. **PART NO. 16-0332**



**BRASS COMPRESSION FITTING ASSORTMENT**  
32 SIZES, 1/4" - 5/8" OD TUBING SIZE, IN  
A LARGE STEEL DRAWER. **PART NO. 16-0432**

## Double Compression Fittings

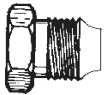

### DOUBLE COMPRESSION NUT

Part No.	Tube Size	Pkg Qty
27-186	1/8	10
27-187	3/16	10
27-188	1/4	10
27-189	5/16	10
27-190	3/8	10

Weatherhead 6100, Edelmann 111/b-11

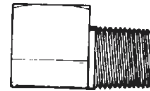

### DOUBLE COMPRESSION MALE ELBOW

*Tube to Male Pipe*

Part No.	Tube Size	Pipe Size	Pkg Qty
27-654	1/8	1/8	10
27-655	3/16	1/8	10
27-656	1/4	1/8	10
27-657	5/16	1/8	10
27-658	3/8	1/4	10

Weatherhead 6400, Edelmann 115/B-15

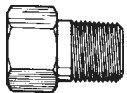

### DOUBLE COMPRESSION MALE CONNECTOR

*Tube to Male Pipe*

Part No.	Tube Size	Pipe Size	Pkg Qty
27-649	1/8	1/8	10
27-650	3/16	1/8	10
27-651	3/16	1/4	10
27-194	1/4	1/8	10
27-652	1/4	1/4	10
27-195	5/16	1/8	10
27-653	5/16	1/4	10
27-197	3/8	1/4	10

Weatherhead 6200, Edelmann 112/B-12



### DOUBLE COMPRESSION UNION

*Tube to Tube*

Part No.	Tube Size	Pkg Qty
27-659	1/8	10
27-191	3/16	10
27-192	1/4	10
27-660	5/16	10
27-193	3/8	10

Weatherhead 6300

# Brass Inverted Flare Fittings



## INVERTED BRASS NUTS

Part No.	Tube Size	Pkg Qty
27-278	1/8	25
27-279	3/16	25
27-280	1/4	25
27-282	3/8	25
27-283	1/2	10

Parker 411F, Weatherhead 100, Edelmann 121/B-21

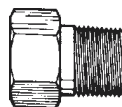

## INVERTED MALE CONNECTOR

Tube To Male Pipe

Part No.	Tube Size	Pipe Size	Pkg Qty
27-661	1/8	1/8	10
27-296	3/16	1/8	10
27-297	1/4	1/8	10
27-298	1/4	1/4	10
27-299	5/16	1/8	10
27-300	5/16	1/4	10
27-301	3/8	1/8	10
27-302	3/8	1/4	10
27-303	3/8	3/8	5
27-304	1/2	1/4	5
27-305	1/2	3/8	5
27-306	1/2	1/2	5

Other sizes available up to 1" tube

Parker 481FHD, Weatherhead 202, Edelmann 124/B-24, Imperial Eastman 48-W



## INVERTED STEEL NUT

Part No.	Tube Size	Pkg Qty
27-284	1/8	25
27-285	3/16	25
27-286	1/4	25
27-287	5/16	25
27-288	3/8	25
27-289	1/2	10

Parker 411FS, Weatherhead 105, Edelmann 123/B-23, Imperial Eastman 42-W

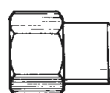

## INVERTED FEMALE CONNECTOR

Tube to Female Pipe

Part No.	Tube Size	Pipe Size	Pkg Qty
27-662	3/16	1/8	10
27-663	1/4	1/8	10
27-664	5/16	1/8	10
27-665	3/8	1/4	10
27-666	1/2	3/8	5

Parker 461FHD, Weatherhead 252, Edelmann 126/B-26, Imperial Eastman 46-W

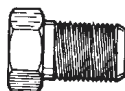

## INVERTED LONG STEEL NUT

PART No.	Tube SIZE	Pkg Qty
27-390	3/16	20
27-391	1/4	10

Weatherhead 7896, Edelmann B21L, Imperial Eastman 41-WL



## INVERTED STEEL PLUG

PART No.	Tube Size	Pkg Qty
27-392	3/16	10
27-393	1/4	10
27-394	5/16	10
27-395	3/8	10

Weatherhead 131, Edelmann 120/B-20, Imperial Eastman 39-W



## INVERTED MALE ELBOW

Tube to Male Pipe

Part No.	Tube Size	Pipe Size	Pkg Qty
27-307	1/8	1/8	10
27-308	3/16	1/8	10
27-309	1/4	1/8	10
27-310	1/4	1/4	10
27-311	5/16	1/8	10
27-312	5/16	1/4	10
27-313	3/8	1/8	10
27-314	3/8	1/4	10
27-315	3/8	3/8	5
27-316	1/2	3/8	5

Parker 2491FHD, Weatherhead 402, Edelmann 122/B-22, Imperial Eastman 49-W



## INVERTED BRASS UNION

Tube to Tube

Part No.	Tube Size	Pkg Qty
27-290	1/8	10
27-291	3/16	10
27-292	1/4	10
27-293	5/16	10
27-294	3/8	10
27-295	1/2	5

Parker 421FHD, Weatherhead 302, Edelmann 123/B23, Imperial Eastman 42-WL



# Brass Inverted Flare Fittings

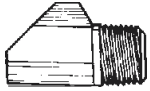

**INVERTED  
45° MALE ELBOW**  
*Tube to Male Pipe*

Part No.	Tube Size	Pipe Size	Pkg Qty
27-318	3/16	1/8	10
27-319	1/4	1/8	10
27-320	5/16	1/8	10
27-321	5/16	1/4	10
27-322	3/8	1/4	10

Parker 259FHD, Weatherhead 352, Edelmann 125/B-25, Imperial Eastman 94-W



**INVERTED  
BRANCH TEE**  
*Tube to Tube to Male Pipe*

Part No.	Tube Size	Pipe Size	Pkg Qty
27-855	3/16	1/8	10
27-856	1/4	1/8	10
27-857	5/16	1/8	10
27-858	3/8	1/4	5

Parker 245IFHD, Weatherhead 602

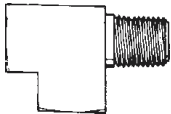

**INVERTED  
RUN TEE**  
*Tube to Male Pipe to Tube*

Part No.	Tube Size	Pipe Size	Pkg Qty
27-859	3/16	1/8	10
27-860	1/4	1/8	10
27-861	5/16	1/8	10
27-862	3/8	1/4	5

Parker 251IFHD, Weatherhead 752



**INVERTED  
UNION TEE**  
*Tube to Tube to Tube*

PART No.	Tube SIZE	Pkg Qty
27-863	3/16	10
27-864	1/4	10
27-865	5/16	10
27-866	3/8	5

Parker 244IFHD, Weatherhead 702

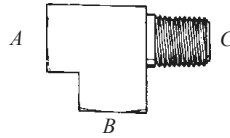

**TOWED TRAILER  
BRAKE TEES FOR  
HYDRAULIC BRAKES**

A - Female Inverted Flare  
B - Female Inverted Flare  
C - Male Inverted Flare

Part No.	Ref. No.	"A" Fem.	"B" Fem.	"C" Male	Pkg Qty
27-867	7898	1/4	1/4	1/4	5
27-868	7899	3/16	1/4	3/16	5
27-869	7900	3/16	3/16	3/16	5
27-870	7901	1/4	3/16	1/4	5
27-881*		1/4	3/16	1/4 npt*	5

Edelmann 127/B-27

\*Pipe thread  
Also available in Metric

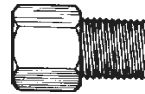

**CONVERSION  
INVERTED FLARE  
ADAPTERS**

*Female Tube to Male Tube*

Part No.	Ref No.	Female Tube	Male Tube	Male Inv.Thd	Pkg Qty
27-871	7818	3/16	1/4	7/16-24	10
27-872	7909	3/16	5/16	1/2-20	10
27-873 <sup>1</sup>	7817	3/16	5/16	1/2-20	10
27-874	7911	3/16	-	9/16-18	10
27-875	7910	3/16	-	9/16-20	10
27-876	7828	1/4	3/16	3/8-24	10
27-877	7829	1/4	5/16	1/2-20	10
27-878 <sup>1</sup>	7727	1/4	5/16	1/2-20	10
27-879 <sup>1</sup>	7732	1/4	-	7/16-20	10
27-880	7908	1/4	-	9/16-18	10
27-882	-	5/16	1/4	7/16-24	10
27-883	-	5/16	5/16	1/2-20	10
27-884	7916	5/16	3/8	5/8-18	10
27-885 <sup>1</sup>	1074	5/16	5/16	1/2-20	10
27-886	7915	3/8	5/16	1/2-20	10
27-888	7913	5/16 <sub>(3/16)</sub> <sup>2</sup>	-	9/16-18	10
27-889	7912	9/16-18	5/16 <sub>(3/16)</sub> <sup>2</sup>	-	10

<sup>1</sup>Seals on hex face

<sup>2</sup>5/16 (1/2-20) thread size with 3/16 inverted seat size



**BRASS INVERTED FLARE  
FITTING ASSORTMENT**  
24 SIZES, 3/16" - 3/8" OD TUBING  
SIZES IN A LARGE STEEL DRAWER.  
**PART NO. 16-4324**

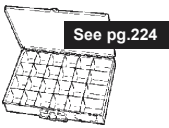

# Brass Air Brake Fittings For Copper Tubing



## AIR BRAKE SLEEVE

Part No.	Tube Size	Pkg Qty
27-198	1/4	100
27-199	5/16	100
27-200	3/8	100
27-201	1/2	50
27-202	5/8	25
27-203	3/4	25

Parker 60AB, Weatherhead 1360, Edelmann 9060, Imperial Eastman 460-F

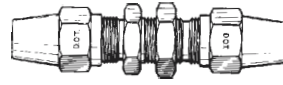

## AIR BRAKE BULKHEAD UNION

*Tube to Tube*

Part No.	Tube Size	Pkg Qty
27-890	1/4	5
27-891	3/8	5
27-892	1/2	5

Parker 62ABH

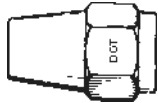

## AIR BRAKE NUT

Part No.	Tube Size	Pkg Qty
27-204	1/4	25
27-205	5/16	25
27-206	3/8	25
27-207	1/2	10
27-208	5/8	10
27-209	3/4	5

Parker 61AB, Weatherhead 1361, Edelmann 9061, Imperial Eastman 461-F

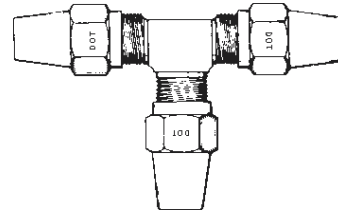

## AIR BRAKE UNION TEE

*Tube to Tube to Tube*

Part No.	Tube Size	Pkg Qty
27-217	1/4	5
27-218	3/8	5
27-219	1/2	5
27-220	5/8	2

Parker 264AB, Weatherhead 1364, Edelmann 9064, Imperial Eastman 464-F



## AIR BRAKE UNION

*Tube to Tube*

Part No.	Tube Size	Pkg Qty
27-211	1/4	10
27-212	5/16	10
27-213	3/8	10
27-214	1/2	5
27-215	5/8	2
27-216	3/4	2

Parker 62AB, Weatherhead 1362, Edelmann 9062, Imperial Eastman 462-F

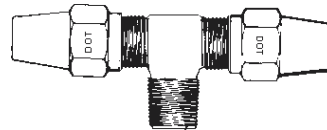

## AIR BRAKE BRANCH TEE

*Tube to Tube to Male Pipe*

Part No.	Tube Size	Pipe Size	Pkg Qty
27-261	3/8	1/8	5
27-262	3/8	1/4	5
27-667	1/2	3/8	5
27-668	5/8	1/2	2
27-669	3/4	1/2	2

Parker 272AB, Weatherhead 1372, Edelmann 9072, Imperial Eastman 472-F

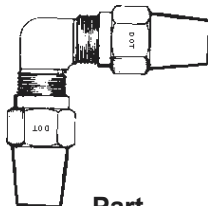

## AIR BRAKE UNION ELBOW

*Tube to Tube*

Part No.	Tube Size	Pkg Qty
27-221	1/4	5
27-222	3/8	5
27-223	1/2	5
27-224	5/8	2

Parker 265AB, Weatherhead 1362, Edelmann 9056, Imperial Eastman 465-F

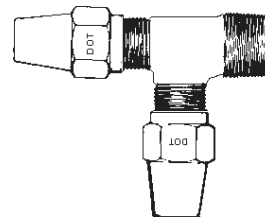

## AIR BRAKE RUN TEE

*Tube to Male Pipe to Tube*

Part No.	Tube Size	Pipe Size	Pkg Qty
27-275	1/4	1/8	5
27-260	3/8	1/4	5
27-276	1/2	3/8	5
27-277	5/8	1/2	2

Parker 271AB, Weatherhead 1382, Edelmann 9071, Imperial Eastman 471-F



# Brass Air Brake Fittings For Copper Tubing

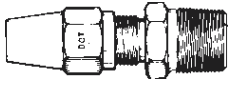

## AIR BRAKE MALE CONNECTOR

*Tube to Male Pipe*

Part No.	Tube Size	Pipe Size	Pkg Qty
27-227	1/4	1/8	10
27-228	1/4	1/4	10
27-229	5/16	1/8	10
27-230	5/16	1/4	10
27-231	3/8	1/8	10
27-232	3/8	1/4	10
27-233	3/8	3/8	10
27-234	3/8	1/2	10
27-235	1/2	1/4	5
27-236	1/2	3/8	5
27-237	1/2	1/2	5
27-238	5/8	3/8	2
27-239	5/8	1/2	2
27-240	5/8	3/4	2
27-241	3/4	1/2	2
27-242	3/4	3/4	2

Parker 68AB, Weatherhead 1368, Edelmann 9068, Imperial Eastman 468-F

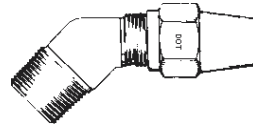

## AIR BRAKE 45° MALE ELBOW

*Tube to Male Pipe*

Part No.	Tube Size	Pipe Size	Pkg Qty
27-263	1/4	1/8	10
27-264	3/8	1/8	10
27-265	3/8	1/4	10
27-266	3/8	3/8	10
27-268	1/2	3/8	5
27-269	1/2	1/2	5
27-270	5/8	1/2	2

Parker 279AB, Imperial Eastman 474-F

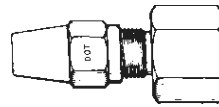

## AIR BRAKE FEMALE CONNECTOR

*Tube to Female Pipe*

Part No.	Tube Size	Pipe Size	Pkg Qty
27-893	1/4	1/8	10
27-894	1/4	1/4	10
27-895	3/8	1/8	10
27-896	3/8	1/4	10
27-897	3/8	3/8	10
27-898	1/2	1/4	5
27-899	1/2	3/8	5
27-900	1/2	1/2	5

Parker 66AB, Edelmann 906/B-1066, Imperial Eastman 466-F

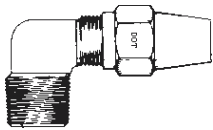

## AIR BRAKE 90° MALE ELBOW

*Tube to Male Pipe*

Part No.	Tube Size	Pipe Size	Pkg Qty
27-243	1/4	1/8	10
27-244	1/4	1/4	10
27-245	5/16	1/8	10
27-246	5/16	1/4	10
27-247	3/8	1/8	10
27-248	3/8	1/4	10
27-249	3/8	3/8	10
27-250	3/8	1/2	5
27-251	1/2	1/4	5
27-252	1/2	3/8	5
27-253	1/2	1/2	5
27-254	5/8	3/8	2
27-255	5/8	1/2	2
27-257	3/4	1/2	2
27-258	3/4	3/4	2

Parker 268AB, Weatherhead 1369, Edelmann 9069, Imperial Eastman 469-F

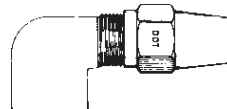

## AIR BRAKE 90° FEMALE ELBOW

*Tube to Female Pipe*

Part No.	Tube Size	Pipe Size	Pkg Qty
27-271	3/8	1/4	5
27-259	3/8	3/8	5
27-272	1/2	3/8	5
27-273	1/2	1/2	5
27-274	5/8	1/2	2

Parker 270AB, Weatherhead 1470, Edelmann 9070, Imperial Eastman 470-F



## BRASS AIRBRAKE FITTING ASSORTMENT

24 SIZES, 1/4" - 1/2" OD SIZES IN A LARGE STEEL DRAWER.

**PART NO. 16-4024**

**Save when you buy in quantity!**



# NTA Brass Air Brake Fittings For Nylon Tubing



## NTA SLEEVE

Part No.	Tube Size	Pkg Qty
5407	1/4	50
5408	3/8	50
5409	1/2	25
5410	5/8	10
5411	3/4	10

Parker 61NTA, Weatherhead 1461, Imperial Eastman 461-FS

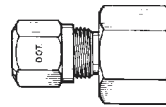

## NTA FEMALE CONNECTOR

Tube to Female Pipe

Part No.	Tube Size	Pipe Size	Pkg Qty
5422	1/4	1/8	5
5423	1/4	1/4	5
5424	3/8	1/4	5
5425	3/8	3/8	5
5426	1/2	3/8	5
5427	1/2	1/2	3
5428	5/8	1/2	2
5429	3/4	1/2	2

Parker 66NTA, Weatherhead 1466, Imperial Eastman 466-F



## NTA NUT

Part No.	Tube Size	Pkg Qty
5401	1/4	25
5402	3/8	25
5403	1/2	10
5404	5/8	10
5405	3/4	5

Parker 60NTA, Weatherhead 1460, Imperial Eastman 4-460-F

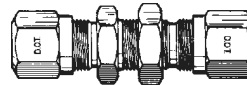

## NTA BULKHEAD UNION

Tube to Tube

Part No.	Tube Size	Pkg Qty
27-904	1/4	5
27-905	3/8	5
27-906	1/2	5

Parker 62NBH, Weatherhead 1474,



## NTA TUBE INSERT

Part No. BRASS	Part No. S/S	Tube O.D.	Insert O.D.	Pkg Qty
27-510	27-901	1/4	.163	25
27-512	27-902	3/8	.245	25
27-513	27-903	1/2	.370	10
-	5415	5/8	.434	10
-	5416	3/4	.559	10

Inserts for other sizes and styles of tubing can be found on Page 217.  
Parker 63NTA, Weatherhead 1484, Imperial Eastman 459-F

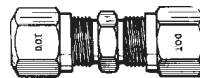

## NTA UNION

Tube to Tube

Part No.	Tube Size	Pkg Qty
5417	1/4	5
5418	3/8	5
5419	1/2	5
5420	5/8	2
5421	3/4	2

Parker 62NTA, Weatherhead 1462, Imperial Eastman 4-462-F

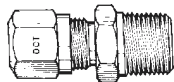

## NTA MALE CONNECTOR

Tube to Male Pipe

Part No.	Tube Size	Pipe Size	Pkg Qty
5432	1/4	1/8	10
5433	1/4	1/4	10
5434	3/8	1/8	5
5435	3/8	1/4	5
5436	3/8	3/8	5
5437	3/8	1/2	3
5438	1/2	1/4	3
5439	1/2	3/8	3
5440	1/2	1/2	3
5441	5/8	1/2	2
5442	3/4	1/2	2
5443	3/4	3/4	2

Parker 68NTA, Weatherhead 1468, Imperial Eastman 4-468-F

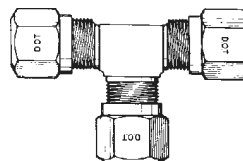

## NTA UNION TEE

Tube to Tube to Tube

Part No.	Tube Size	Pkg Qty
5466	1/4	2
5467	3/8	2
5468	1/2	2

Parker 264NTA, Weatherhead 1464, Imperial Eastman 4-464-F

**Tips: Use Air Brake Fittings for Copper Tubing and an Insert to make D.O.T. approved fittings for nylon air brake tubing.**



# NTA Brass Air Brake Fittings For Nylon Tubing

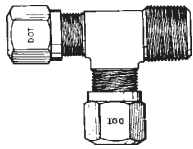

## NTA MALE RUN TEE

Tube to Male Pipe to Tube

Part No.	Tube Size	Pipe Size	Pkg Qty
5469	1/4	1/8	2
5470	3/8	1/4	2
5471	1/2	3/8	2

Parker 271NTA, Weatherhead 1471, Imperial Eastman 4-471-F

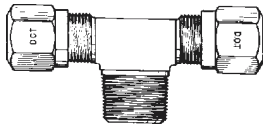

## NTA MALE BRANCH TEE

Tube to Tube to Male Pipe

Part No.	Tube Size	Pipe Size	Pkg Qty
5472	1/4	1/8	2
5473	3/8	1/4	2
5474	1/2	3/8	2
5475	1/2	1/2	2

Parker 272NTA, Weatherhead 1472, Imperial Eastman 4-472-F

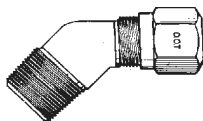

## NTA 45° MALE ELBOW

Tube to Male Pipe

Part No.	Tube Size	Pipe Size	Pkg Qty
5460	1/4	1/8	5
5461	1/4	1/4	5
5462	3/8	1/4	5
5463	3/8	3/8	5
5464	1/2	3/8	3
5465	5/8	1/2	2

Parker 279NTA, Weatherhead 1480, Imperial Eastman 4-474-F

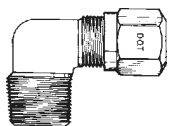

## NTA 90° MALE ELBOW

Tube to Male Pipe

Part No.	Tube Size	Pipe Size	Pkg Qty
5445	1/4	1/8	5
5446	1/4	1/4	5
5447	3/8	1/4	5
5448	3/8	3/8	5
5449	3/8	1/2	5
5450	1/2	3/8	3
5451	1/2	1/2	3
5452	5/8	1/2	2

Parker 269NTA, Weatherhead 1469, Imperial Eastman 4-469-F

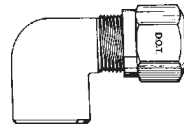

## NTA 90° FEMALE ELBOW

Tube to Female Pipe

Part No.	Tube Size	Pipe Size	Pkg Qty
5453	1/4	1/8	5
5454	1/4	1/4	5
5455	3/8	1/4	3
5456	3/8	3/8	3
5457	1/2	3/8	3
5458	1/2	1/2	3
5459	5/8	1/2	2

Parker 270NTA, Weatherhead 1470

## SPLIT SLEEVE BRASS FITTINGS

Used on Eaton-Fuller Transmission Shifters. For use with Nylon Air Brake Tubing. 5/32" size supplied with a built-in tube support.



### SLEEVE

Part No.	Tube Size	Pkg Qty
5406	1/8	50
27-907	5/32	50



### NUT

Part No.	Tube Size	Pkg Qty
5400	1/8	25
27-908	5/32	25



### UNION

Tube to Tube

Part No.	Tube Size	Pkg Qty
5414	1/8	5
27-909	5/32	5

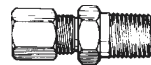

### MALE CONNECTOR

Tube to Male Pipe

Part No.	Tube Size	Pipe Size	Pkg Qty
5430	1/8	1/16	10
5431	1/8	1/8	10
27-910	5/32	1/16	10
27-911	5/32	1/8	10



### 90° MALE ELBOW

Tube to Male Pipe

Part No.	Tube Size	Pipe Size	Pkg Qty
27-912	1/8	1/16	5
5444	1/8	1/8	5
27-913	5/32	1/8	5



**BRASS AIRBRAKE NTA FITTING ASSORTMENT**  
24 SIZES, 1/4" - 5/8" OD SIZES  
IN A LARGE STEEL DRAWER.  
**PART NO. 16-4124**

# Brass Flare Fittings, SAE 45°

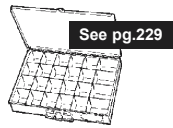

## SHORT FLARE NUT

Part No.	Tube Size	Pkg Qty
27-633	1/8	25
27-361	3/16	25
27-362	1/4	25
27-363	5/16	25
27-364	3/8	10
27-365	1/2	10
27-366	5/8	5
27-367	3/4	5

Parker 41FS, Weatherhead 1110, Edelmann 141/B-41S, Imperial Eastman 41-F

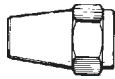

## LONG FLARE NUT

Part No.	Tube Size	Pkg Qty
27-368	1/8	25
27-369	3/16	25
27-370	1/4	25
27-371	5/16	25
27-372	3/8	10
27-373	1/2	10
27-374	5/8	5

Parker 41FL, Weatherhead 41-F, Edelmann 141/B-41, Imperial Eastman 641-F



## FLARE CAP

Part No.	Tube Size	Pkg Qty
27-379	1/4	10
27-380	3/8	10
27-381	1/2	10

Parker 640F, Imperial Eastman 640-FB



## FLARE PLUG

Part No.	Tube Size	Pkg Qty
27-386	1/4	10
27-387	3/8	10

Parker 639F, Imperial Eastman 639-F



## FLARE GASKET

Part No.	Tube Size	Pkg Qty
27-914	1/4	25
27-915	5/16	25
27-916	3/8	25
27-917	1/2	25

Parker 2GF, Imperial Eastman 625-F



## FLARE SWIVEL CONNECTOR

*Tube to Tube*

Part No.	Tube Size	Pkg Qty
27-918	1/4	5
27-919	5/16	5
27-920	3/8	5
27-921	1/2	5

Parker 14FSV



## FEMALE FLARE CONNECTOR

*Tube to Tube*

USE PROPER SIZE COPPER GASKET ON EACH END.

Part No.	Tube Size	Pkg Qty
27-922	1/4	5
27-924	3/8	5
27-925	1/2	5

Parker 660FHD

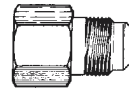

## FEMALE FLARE TO MALE FLARE REDUCER

*Tube to Tube*

USE PROPER SIZE COPPER GASKET ON FEMALE FLARE END.

Part No.	Tube Size		Pkg Qty
	Female	Male	
27-926	1/4	3/8	5
27-927	3/8	1/4	5
27-928	3/8	1/2	5
27-929	3/8	5/8	5
27-930	1/2	1/4	5
27-931	1/2	3/8	5
27-932	1/2	5/8	5

Parker 661FHD, Imperial Eastman 661-FA



## FLARE REDUCING UNION

*Tube to Tube*

Part No.	Tube Size	Tube Size	Pkg Qty
27-933	5/16	1/4	10
27-934	3/8	1/4	10
27-935	3/8	5/16	10
27-936	1/2	1/4	5
27-937	1/2	3/8	5
27-938	5/8	1/2	5

Parker 42F, Imperial Eastman 656-F



## FLARE UNION

*Tube to Tube*

Part No.	Tube Size	Pkg Qty
27-634	1/8	10
27-441	3/16	10
27-442	1/4	10
27-443	5/16	10
27-444	3/8	10
27-445	1/2	5
27-446	5/8	5
27-447	3/4	5

Parker 42F, Weatherhead 42, Edelmann 142/B-42, Imperial Eastman 642-F



# Brass Flare Fittings, SAE 45°

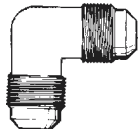

## FLARE UNION ELBOW

*Tube to Tube*

Part No.	Tube Size	Pkg Qty
27-353	1/4	10
27-354	5/16	10
27-355	3/8	5
27-356	1/2	5

Parker 155F, Weatherhead 55, Edelmann 155/B-55, Imperial Eastman 649-F



## FEMALE FLARE TO MALE PIPE ADAPTER

*Tube to Male Pipe*

USE PROPER SIZE COPPER GASKET ON FEMALE FLARE END.

Part No.	Tube Size	Pipe Size	Pkg Qty
27-939	1/4	1/8	10
27-940	1/4	1/4	10
27-941	3/8	1/4	10
27-942	3/8	3/8	10
27-943	1/2	3/8	5
27-944	1/2	1/2	5

Parker 664FHD, Imperial Eastman 664-F

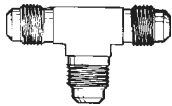

## FLARE UNION TEE

*Tube to Tube to Tube*

Part No.	Tube Size	Pkg Qty
27-413	1/4	5
27-414	3/8	5
27-635	1/2	5
27-636	5/8	5

Parker 144F, Weatherhead 44, Edelmann 144/B-44, Imperial Eastman 644-F

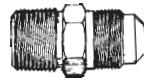

## FLARE MALE CONNECTOR

*Tube to Male Pipe*

Part No.	Tube Size	Pipe Size	Pkg Qty
27-421	1/8	1/8	10
27-422	3/16	1/8	10
27-423	3/16	1/4	10
27-424	1/4	1/8	10
27-425	1/4	1/4	10
27-426	1/4	3/8	10
27-427	5/16	1/8	10
27-428	5/16	1/4	10
27-429	3/8	1/8	10
27-430	3/8	1/4	10
27-431	3/8	3/8	10
27-432	3/8	1/2	10
27-433	1/2	1/4	5
27-434	1/2	3/8	5
27-435	1/2	1/2	5
27-436	5/8	3/8	5
27-437	5/8	1/2	5
27-438	5/8	3/4	5
27-439	3/4	1/2	5
27-440	3/4	3/4	5

Parker 48F, Weatherhead 48, Edelmann 148/B-48, Imperial Eastman 648-F

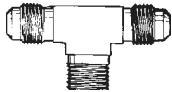

## FLARE MALE BRANCH TEE

*Tube to Tube to Male Pipe*

Part No.	Tube Size	Pipe Size	Pkg Qty
27-405	3/16	1/8	5
27-406	1/4	1/8	5
27-407	1/4	1/4	5
27-408	5/16	1/4	5
27-409	3/8	1/4	5
27-410	3/8	3/8	5
27-411	1/2	3/8	5
27-412	1/2	1/2	5
27-637	5/8	3/8	5
27-638	5/8	1/2	5

Parker 145F, Weatherhead 45, Edelmann 145/B-45, Imperial Eastman 645-F

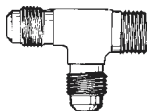

## FLARE MALE RUN TEE

*Tube to Male Pipe to Tube*

Part No.	Tube Size	Pipe Size	Pkg Qty
27-416	1/4	1/8	5
27-417	1/4	1/4	5
27-418	3/8	1/4	5
27-639	1/2	3/8	5
27-640	5/8	1/2	5

Parker 151F, Weatherhead 51, Edelmann 151/B-51, Imperial Eastman 651-F

# Red Hot Deals!

Check out our current specials and new items on our website at <http://www.mpi-online.com>

# Brass Flare Fittings, SAE 45°

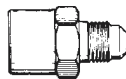

## FLARE FEMALE CONNECTOR

*Tube to Female Pipe*

Part No.	Tube Size	Pipe Size	Pkg Qty
27-448	1/8	1/8	10
27-449	3/16	1/8	10
27-450	1/4	1/8	10
27-451	1/4	1/4	10
27-452	1/4	3/8	10
27-453	5/16	1/8	10
27-454	5/16	1/4	10
27-455	3/8	1/8	10
27-456	3/8	1/4	10
27-457	3/8	3/8	10
27-458	3/8	1/2	10
27-459	1/2	1/4	5
27-460	1/2	3/8	5
27-461	1/2	1/2	5
27-643	5/8	1/2	5

Parker 46F, Weatherhead 46, Edelmann 146/B-46, Imperial Eastman 646-F

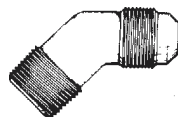

## 45° MALE ELBOW

*Tube to Male Pipe*

Part No.	Tube Size	Pipe Size	Pkg Qty
27-644	1/4	1/8	10
27-348	1/4	1/4	10
27-349	3/8	1/4	10
27-350	3/8	3/8	10
27-351	1/2	3/8	5
27-352	1/2	1/2	5

Parker 159F, Weatherhead 54, Imperial Eastman 654-F

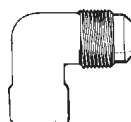

## FLARE 90° FEMALE ELBOW

*Tube to Female Pipe*

Part No.	Tube Size	Pipe Size	Pkg Qty
27-357	1/4	1/8	10
27-358	1/4	1/4	10
27-645	5/16	1/4	10
27-359	3/8	1/4	10
27-360	3/8	3/8	10

Parker 150F, Weatherhead 50, Edelmann 150/B-50, Imperial Eastman 650-F

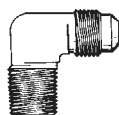

## FLARE 90° MALE ELBOW

*Tube to Male Pipe*

Part No.	Tube Size	Pipe Size	Pkg Qty
27-330	1/8	1/8	10
27-331	3/16	1/8	10
27-332	1/4	1/8	10
27-333	1/4	1/4	10
27-334	1/4	3/8	10
27-335	5/16	1/8	10
27-336	5/16	1/4	10
27-337	3/8	1/8	10
27-338	3/8	1/4	10
27-339	3/8	3/8	10
27-340	3/8	1/2	10
27-341	1/2	1/4	5
27-342	1/2	3/8	5
27-343	1/2	1/2	5
27-344	1/2	3/4	5
27-345	5/8	3/8	5
27-346	5/8	1/2	5
27-347	5/8	3/4	5
27-641	3/4	1/2	5
27-642	3/4	3/4	5

Parker 149F, Weatherhead 49



**SAE 45° FLARE FITTING ASSORTMENT**  
24 SIZES, 1/4" - 1/2" OD COPPER TUBING FITTINGS IN A LARGE STEEL DRAWER. **PART NO. 16-4224**



# Poly-Tite Brass Fittings



## POLY-TITE SLEEVE

An acetal resin (plastic) sleeve that remains captive in the nut. Brass sleeves in 1/8 and 3/16 available on special order

Part No.	Tube Size	Pkg Qty
27-522	1/4	100
27-523	5/16	100
27-524	3/8	100
27-702	1/2	100

Parker 60P, Imperial Eastman 260-P

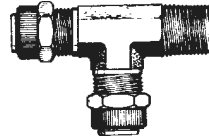

## POLY-TITE MALE RUN TEE

Tube to Male Pipe to Tube

Part No.	Tube Size	Pipe Size	Pkg Qty
27-577	1/4	1/8	5
27-578	1/4	1/4	5
27-673	3/8	1/4	5

Parker 171P, Imperial Eastman 271-P



## POLY-TITE NUT AND SLEEVE ASSEMBLY

A two piece assembly consisting of a brass tube nut and captive plastic sleeve. The brass tube nut alone is available on special order.

Part No.	Tube Size	Pkg Qty
27-674	1/8*	25
27-526	3/16*	25
27-527	1/4	25
27-528	5/16	25
27-529	3/8	25
27-530	1/2	25

Parker 61P, Imperial Eastman 261-P

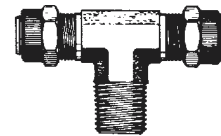

## POLY-TITE MALE BRANCH TEE

Tube to Tube to Male Pipe

Part No.	Tube Size	Pipe Size	Pkg Qty
27-579	3/16*	1/8	5
27-580	1/4	1/8	5
27-581	1/4	1/4	5
27-582	3/8	1/4	5

Parker 172P, Imperial Eastman 272-P

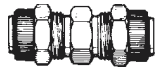

## POLY-TITE UNION

Tube to Tube

Part No.	Tube Size	Pkg Qty
27-533	1/8*	10
27-534	3/16*	10
27-535	1/4	10
27-536	5/16	10
27-537	3/8	10
27-538	1/2	10

Parker 62P, Imperial Eastman 262-P

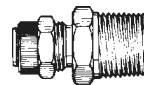

## POLY-TITE MALE CONNECTOR

Tube to Male Pipe

Part No.	Tube Size	Pipe Size	Pkg Qty
27-485	1/8*	1/16	10
27-486	1/8*	1/8	10
27-554	3/16*	1/8	10
27-555	1/4	1/8	10
27-556	1/4	1/4	10
27-557	1/4	3/8	5
27-558	5/16	1/8	10
27-559	5/16	1/4	10
27-560	3/8	1/8	10
27-561	3/8	1/4	10
27-562	3/8	3/8	5
27-563	1/2	3/8	5

Parker 68P, Imperial Eastman 268-P

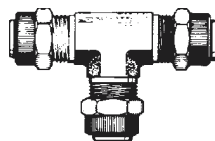

## POLY-TITE UNION TEE

Tube to Tube to Tube

Part No.	Tube Size	Pkg Qty
27-672	1/8*	5
27-541	3/16*	5
27-542	1/4	5
27-543	5/16	5
27-544	3/8	5
27-545	1/2	5

Parker 164P & 264P, Imperial Eastman 264-P

\* 1/8 and 3/16 tube size sleeves supplied in brass and do not have tube support.

**Save when you buy in quantity!**

# Poly-Tite Brass Fittings

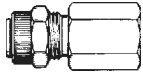

## POLY-TITE FEMALE CONNECTOR

Tube to Female Pipe

Part No.	Tube Size	Pipe Size	Pkg Qty
27-671	1/8**	1/8	10
27-546	3/16**	1/8	10
27-547	3/16**	1/4	10
27-548	1/4	1/8	10
27-549	1/4	1/4	10
27-550	5/16	1/8	5
27-551	3/8	1/4	5
27-552	1/2	3/8	5

Parker 66P, Imperial Eastman 266-P

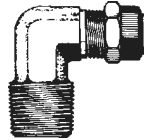

## POLY-TITE 90° MALE ELBOW

Tube to Male Pipe

Part No.	Tube Size	Pipe Size	Pkg Qty
27-670	1/8**	1/8	5
27-565	3/16**	1/8	10
27-566	1/4	1/8	10
27-567	1/4	1/4	10
27-568	1/4	3/8	5
27-569	5/16	1/8	10
27-570	3/8	1/8	10
27-571	3/8	1/4	10
27-572	3/8	3/8	5
27-573	1/2	3/8	5

Parker 169P & 269P, Imperial Eastman 269-P

\*\* 1/8 and 3/16 tube size sleeves supplied in brass and do not have tube support.

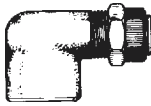

## POLY TITE 90° FEMALE ELBOW

Tube to Female Pipe

Part No.	Tube Size	Pipe Size	Pkg Qty
27-574	1/4	1/8	10
27-575	1/4	1/4	10
27-576	3/8	1/4	10

Parker 170P, Imperial Eastman 270-P

**Custom assortments  
made to your specifications!**

# Push-In Brass Fittings

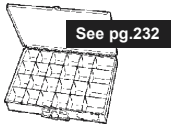

See pg.232

- **INDUSTRIAL STYLE** for use with standard pressure plastic tubings
- **AIRBRAKE STYLE** for use with SAE J844 Nylon Air Brake Tubing have built-in tubing support
  - O-ring seal holds pressures up to that of the tubing being used
- Easy to use; simply cut tubing square and push into the fitting
- Emergency repairs are quick
- To remove old tubing, just push on the brass release collar and pull the tubing out.
- Fittings do not need to be removed to install new tubing

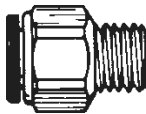

## PUSH-IN MALE CONNECTOR

Tube to Male Pipe

Industrial Style	Airbrake Style*	Tube Size	Pipe Size	Pkg Qty
27-945	-	1/8	1/8	10
27-946	27-987	1/4	1/8	10
27-947	27-988	1/4	1/4	10
27-948	-	3/8	1/8	10
27-949	27-989	3/8	1/4	10
27-950	27-990	3/8	3/8	5
....-	27-991	3/8	1/2	2
27-951	27-992	1/2	3/8	5
....-	27-993	1/2	1/2	2

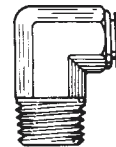

## PUSH-IN 90° RIGID MALE ELBOW

Tube to Male Pipe

Industrial Style	Airbrake Style*	Tube Size	Pipe Size	Pkg Qty
27-952	-	1/8	1/8	5
27-953	27-994	1/4	1/8	5
27-954	27-995	1/4	1/4	5
27-955	-	3/8	1/8	5
27-956	27-996	3/8	1/4	5
27-957	27-997	3/8	3/8	5
27-958	27-998	1/2	3/8	5
....-	27-999	1/2	1/2	2

\*Airbrake Style Push-In Fittings are marked "D.O.T."



# Push-In Brass Fittings (Cont'd)

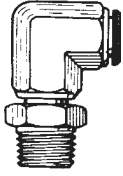

**PUSH-IN  
90° SWIVEL MALE  
ELBOW**

*Tube to Male Pipe*

Industrial Style	Airbrake Style*	Tube Size	Pipe Size	Pkg Qty
27-959	-	1/8	1/8	5
27-960	27-1000	1/4	1/8	5
27-961	27-1001	1/4	1/4	5
27-963	27-1002	3/8	1/4	5
27-964	27-1003	3/8	3/8	5
27-965	27-1004	1/2	3/8	5
....-	27-1005	1/2	1/2	2

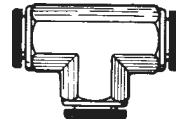

**PUSH-IN  
UNION TEE**

*Tube to Tube to Tube*

Industrial Style	Airbrake Style*	Tube Size	Pkg Qty
27-970	-	1/8	5
27-971	27-1009	1/4	5
27-972	27-1010	3/8	2
27-973	27-1011	1/2	2

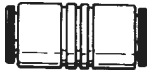

**PUSH-IN  
UNION**

*Tube to Tube*

Industrial Style	Airbrake Style*	Tube Size	Pkg Qty
27-966	-	1/8	10
27-967	27-1006	1/4	10
27-968	27-1007	3/8	5
27-969	27-1008	1/2	5

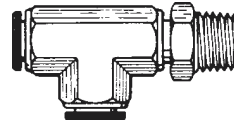

**PUSH-IN  
SWIVEL MALE  
RUN TEE**

*Tube to Male Pipe to Tube*

Industrial Style	Tube Size	Pipe Size	Pkg Qty
27-974	1/8	1/8	5
27-975	1/4	1/8	5
27-976	1/4	1/4	5
27-977	3/8	1/4	2
27-978	3/8	3/8	2
27-979	1/2	3/8	2

**TIPS:**

Drivers should carry Airbrake Style Tube Unions in all three diameters for road repair of broken lines. Since no tools are required (except a knife to cut out the bad section) the repair is quick, simple and safe.



**INDUSTRIAL PUSH-IN FITTING ASSORTMENT**  
19 SIZES, 1/8" - 1/2" OD IN A LARGE STEEL DRAWER. **PART NO. 16-5924**

**AIRBRAKE PUSH-IN FITTING ASSORTMENT**  
ALL DOT APPROVED FITTINGS. 1/8" - 1/2" OD IN A LARGE STEEL DRAWER. **PART NO. 16-6224**

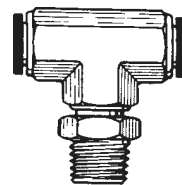

**PUSH-IN  
SWIVEL MALE  
BRANCH TEE**

*Tube to Tube to Male Pipe*

Industrial Style	Tube Size	Pipe Size	Pkg Qty
27-980	1/8	1/8	5
27-981	1/4	1/8	5
27-982	1/4	1/4	5
27-983	3/8	1/8	2
27-984	3/8	1/4	2
27-985	3/8	3/8	2
27-986	1/2	3/8	2

*\*Airbrake Style Push-In Fittings are marked "D.O.T."*





# Acetal Instant Push-In Tube Fittings

Used in agricultural fertilizer applications, air lines and sanitary lines. Made of FDA and NSF-61 approved materials. Temperature range: -4°F to 158°F. Working pressure: 1/4" 230 psi, 3/8" & 1/2" 150 psi. Warning: Not for Truck Airbrake use.



## PUSH-IN MALE CONNECTOR

Tube to Male Pipe

Part No.	Tube Size	Pipe Size	Pkg Qty
13-550	1/4	1/8	10
13-551	1/4	1/4	10
13-552	1/4	3/8	10
13-553	3/8	1/8	10
13-554	3/8	1/4	10
13-555	3/8	3/8	10
13-556	3/8	1/2	10
13-557	1/2	3/8	10
13-558	1/2	1/2	10



## PUSH-IN UNION

Tube to Tube

Part No.	Tube Size	Pkg Qty
13-573	1/4	10
13-574	3/8	10
13-575	1/2	10



## PUSH-IN UNION 90° ELBOW

Tube to Tube

Part No.	Tube Size	Pkg Qty
13-576	1/4	10
13-577	3/8	10
13-578	1/2	10



## PUSH-IN 90° MALE ELBOW

Tube to Male Pipe

Part No.	Tube Size	Pipe Size	Pkg Qty
13-559	1/4	1/8	10
13-560	1/4	1/4	10
13-561	1/4	3/8	10
13-562	3/8	1/4	10
13-563	3/8	3/8	10



## PUSH-IN UNION

Tube to Tube

Part No.	Tube Size	Pkg Qty
13-579	1/4	10
13-580	3/8	10
13-581	1/2	10



## PUSH-IN 90° MALE SWIVEL ELBOW

Tube to Male Pipe

Part No.	Tube Size	Pipe Size	Pkg Qty
13-564	1/4	1/8	10
13-565	1/4	1/4	10
13-566	1/4	3/8	10
13-567	3/8	1/8	10
13-568	3/8	1/4	10
13-569	3/8	3/8	10
13-570	1/2	1/4	10
13-571	1/2	3/8	10
13-572	1/2	1/2	10



## PUSH-IN MALE STEM CONNECTORS

Tube to Male Pipe

Use to create a male swivel connectors, run or branch tees, and swivel elbows from union fittings. Just plug it in!

Part No.	Tube Size	Pipe Size	Pkg Qty
13-582	1/4	1/8	10
13-583	1/4	1/4	10
13-584	3/8	1/4	10
13-585	3/8		
13-586	1/2		
13-587	1/2		
13-588	1/2		

ACETAL INSTANT PUSH-IN FITTING ASSORTMENT  
19 SIZES, 1/4" AND 3/8" OD FITTINGS IN A LARGE STEEL DRAWER. PART NO. 16-6024



# Nylon Compression Fittings



Molded nylon for extra strength. Use with polyethylene or nylon tubing. All compression nuts are complete with 'built-in' plastic ferrules. Leak-proof, vibration-proof and corrosion-proof.  
All nylon construction - No metal parts! No o-rings!



## NYLON COMPRESSION NUT ASSEMBLY

*With 'built-in' plastic ferrules*

Part No.	Tube Size	Pkg Qty
27-1012	1/4	25
27-1013	3/8	25
27-1014	1/2	10

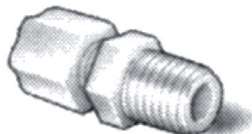

## NYLON COMPRESSION MALE CONNECTOR

*Tube to Male Pipe.*

Part No.	Tube Size	Pipe Size	Pkg Qty
27-1021	1/4	1/8	10
27-1022	1/4	1/4	10
27-1023	3/8	1/4	10
27-1024	3/8	3/8	10
27-1025	1/2	3/8	5
27-1026	1/2	1/2	5

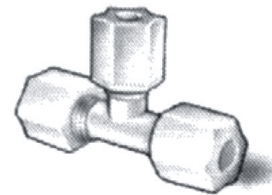

## NYLON COMPRESSION UNION TEE

*Tube to Tube to Tube.*

Part No.	Tube Size	Pkg Qty
27-1033	1/4	5
27-1034	3/8	5
27-1035	1/2	5



## NYLON TUBE INSERT

*Support sleeve for soft wall tubing.*

Part No.	Tube Size	Pkg Qty
27-1015	1/4	25
27-1016	3/8	25
27-1017	1/2	10

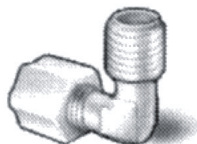

## NYLON COMPRESSION 90° MALE ELBOW

*Tube to Male Pipe.*

Part No.	Tube Size	Pipe Size	Pkg Qty
27-1027	1/4	1/8	10
27-1028	1/4	1/4	10
27-1029	3/8	1/4	10
27-1030	3/8	3/8	10
27-1031	1/2	3/8	5
27-1032	1/2	1/2	5

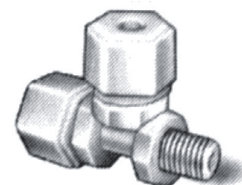

## NYLON COMPRESSION MALE RUN TEE

*Tube to Male Pipe to Tube.*

Part No.	Tube Size	Pipe Size	Pkg Qty
27-1036	1/4	1/4	10
27-1037	3/8	3/8	10



## NYLON COMPRESSION UNION

*Tube to Tube.*

Part No.	Tube Size	Pkg Qty
27-1018	1/4	10
27-1019	3/8	10
27-1020	1/2	5

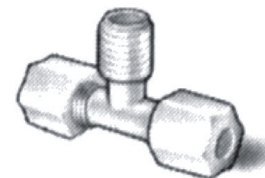

## NYLON COMPRESSION MALE BRANCH TEE

*Tube to Tube to Male Pipe.*

Part No.	Tube Size	Pipe Size	Pkg Qty
27-1038	1/4	1/4	10
27-1039	3/8	3/8	10



## Double Wall Steel Tubing



Automotive grade. Constructed of the same material as standard brake lines. Tin coated. Bends and flares easily. Wall thickness: .028". 25 ft per roll.

Part No.	Size O.D.	Pkg
15-114	3/16	1 RL
15-115	1/4	1 RL
15-116	5/16	1 RL
15-117	3/8	1 RL

## Brass Inverted Flare Union

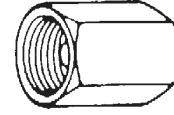

Tube Size	Part No.	Pkg Qty
3/16	27-291	10
1/4	27-292	10
5/16	27-293	10
3/8	27-294	10

## Brake Line Racks



Wall mountable rack holds all popular length brake lines. *Brake lines sold separately.*

Part No.	Holds Sizes
98-016	3/16 and 1/4 O.D.
98-017	5/16 O.D.
98-018	3/8 O.D.

## Short Inverted Flare Nut



Tube Size	Brass Part No.	Steel Part No.	Pkg Qty
3/16	27-279	27-285	25
1/4	27-280	27-286	25
5/16	27-281	27-287	25
3/8	27-282	27-288	25

## Long Steel Flare Nut



Tube Size	Part No.	Pkg Qty
3/16	27-390	20
1/4	27-391	10

See "Inverted Flare Fittings" on pages 221 & 222

## Steel Hydraulic Brake Lines



Double wall, copper fused, double flared, and tin coated. Annealed for easy bending. Resists kinking.

TUBE SIZE	8"	12"	20"	30"	40"	51"	60"	Pkg
3/16"	99-190	99-192	99-196	99-200	99-206	99-211	99-215	10
1/4"	99-191	99-193	99-197	99-201	99-207	99-212	99-216	10
5/16"	-	99-194	99-198	99-202	99-208	99-213	99-217	5
3/8"	-	99-195	99-199	99-203	99-209	99-214	99-218	5



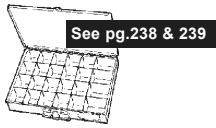

# Brass Pipe Fittings

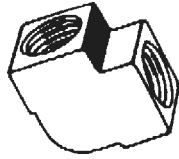

## Brass Pipe 90° Elbow

*Extruded Automotive Design*

Part No.	Pipe Size	Pkg Qty
13-136	1/8	10
13-137	1/4	10
13-138	3/8	5
13-367	1/2	5
Reducing Sizes		
13-411	1/4 x 1/8	5
13-412	3/8 x 1/4	5
13-413	1/2 x 3/8	5

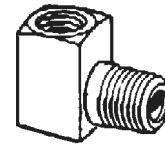

## Brass Pipe 90° Street Elbow

*Extruded Automotive Design*

Part No.	Pipe Size	Pkg Qty
13-153	1/8	10
13-154	1/4	10
13-155	3/8	5
13-156	1/2	5

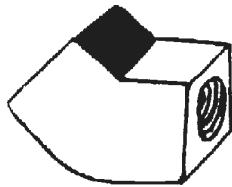

## Brass Pipe 45° Elbow

*Extruded Automotive Design*

Part No.	Pipe Size	Pkg Qty
13-145	1/8	5
13-146	1/4	5
13-147	3/8	5
13-368	1/2	5



## Brass Pipe 45° Street Elbows

*Extruded Automotive Design*

Part No.	Pipe Size	Pkg Qty
13-159	1/8	10
13-160	1/4	10
13-161	3/8	5
13-162	1/2	5

*If man evolved  
from monkeys and apes,  
why do we still have  
monkeys and apes?*

VISIT OUR WEBSITE  
**mpi-online.com**  
FAX ANYTIME!  
**219-696-6413**

# Brass Pipe Fittings



## Brass Pipe 90° Male Elbow

*Forged*

Part No.	Pipe Size	Pkg Qty
13-173 .....	1/8 .....	5
13-174 .....	1/4 .....	5
13-175 .....	3/8 .....	5
13-379 .....	1/2 .....	5

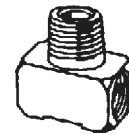

## Brass Pipe Branch Tee

*Extruded Automotive Design*

Part No.	Pipe Size	Pkg Qty
13-382 .....	1/8 .....	5
13-383 .....	1/4 .....	5
13-384 .....	3/8 .....	5
13-385 .....	1/2 .....	5

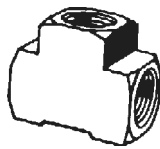

## Brass Pipe Tee

*Extruded Automotive Design*

Part No.	Pipe Size	Pkg Qty
13-212 .....	1/8 .....	5
13-213 .....	1/4 .....	5
13-214 .....	3/8 .....	5
13-215 .....	1/2 .....	5

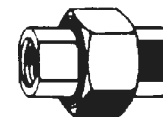

## Brass Pipe Unions

Part No.	Pipe Size	Pkg Qty
13-203 .....	1/8 .....	2
13-204 .....	1/4 .....	2
13-205 .....	3/8 .....	2
13-206 .....	1/2 .....	2
13-207 .....	3/4 .....	2

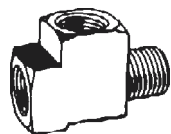

## Brass Pipe Run Tee

*(Street Tee)*

*Extruded Automotive Design*

Part No.	Pipe Size	Pkg Qty
13-238 .....	1/8 .....	5
13-239 .....	1/4 .....	5
13-240 .....	3/8 .....	5
13-380 .....	1/2 .....	5
13-381 .....	3/4 .....	2

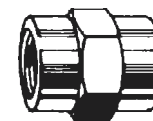

## Brass Pipe Couplings

*Extruded Automotive Design*

Part No.	Pipe Size	Pkg Qty
13-194 .....	1/8 .....	10
13-195 .....	1/4 .....	10
13-196 .....	3/8 .....	5
13-197 .....	1/2 .....	5
13-198 .....	3/4 .....	2



# Brass Pipe Fittings



## Brass Reducing Couplings

(Bell Reducers)  
Hex Automotive Design

Part No.	Pipe Size	Pkg Qty
13-222	1/4 x 1/8	10
13-223	3/8 x 1/8	5
13-224	3/8 x 1/4	5
13-225	1/2 x 1/4	5
13-226	1/2 x 3/8	5
13-227	3/4 x 1/4	2
13-228	3/4 x 3/8	2
13-229	3/4 x 1/2	2
13-230	1 x 3/4	2



## Brass Pipe Bushings

Part No.	Male Pipe	Female Pipe	Pkg Qty
13-241	1/4	1/8	10
13-242	3/8	1/8	10
13-243	3/8	1/4	10
13-244	1/2	1/8	5
13-245	1/2	1/4	5
13-246	1/2	3/8	10
13-247	3/4	1/8	5
13-248	3/4	1/4	5
13-249	3/4	3/8	5
13-250	3/4	1/2	5
13-251	1	1/4	5
13-252	1	3/8	5
13-253	1	1/2	5
13-254	1	3/4	5



## Brass Pipe Caps

Hex Automotive Design

Part No.	Pipe Size	Pkg Qty
13-186	1/8	10
13-187	1/4	10
13-188	3/8	10
13-389	1/2	10
13-390	3/4	5



## Brass Square Head Pipe Plugs

Part No.	Pipe Size	Pkg Qty
13-164	1/8	10
13-165	1/4	10
13-166	3/8	10
13-167	1/2	10
13-168	3/4	5
13-169	1	5
13-170	1-1/4	2
13-171	1-1/2	2
13-172	2	2



**BRASS PIPE FITTING ASSORTMENT**  
28 SIZES, 1/8" - 1/2" PIPE IN A LARGE  
STEEL DRAWER. **PART NO. 16-5832**



# Brass Pipe Fittings

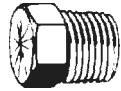

## Brass Hex Head Pipe Plugs

Part No.	Pipe Size	Pkg Qty
13-176	1/8	10
13-177	1/4	10
13-178	3/8	10
13-179	1/2	10
13-180	3/4	5
13-392	1	5

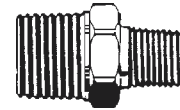

## Brass Reducing Hex Nipples

Part No.	Pipe Size	Pkg Qty
13-405	1/4 x 1/8	10
13-406	3/8 x 1/8	5
13-407	3/8 x 1/4	5
13-408	1/2 x 1/4	5
13-409	1/2 x 3/8	5
13-410	3/4 x 1/2	5



## Brass Socket Pipe Plugs

*Hex Countersunk*

Part No.	Pipe Size	Pkg Qty
13-181	1/8	10
13-182	1/4	10
13-183	3/8	10
13-184	1/2	10

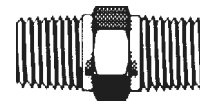

## Brass Hex Nipples

Part No.	Pipe Size	Pkg Qty
13-267	1/8	10
13-268	1/4	10
13-269	3/8	5
13-270	1/2	5
13-271	3/4	5
13-272	1	2

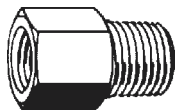

## Brass Pipe Adapters

Part No.	Female Pipe	Male Pipe	Pkg Qty
13-231	1/8	1/8	10
13-232	1/4	1/8	10
13-233	1/4	1/4	10
13-402	3/8	1/8	5
13-234	3/8	1/4	5
13-235	3/8	3/8	5
13-403	1/2	1/4	5
13-236	1/2	3/8	5
13-237	1/2	1/2	5
13-404	3/4	1/2	5



**BRASS HEX PIPE FITTING ASSORTMENT**  
32 SIZES, 1/8" - 3/8" PIPE IN A LARGE STEEL DRAWER. **PART NO. 16-0232**



# Brass Pipe Nipples



Part No.	Size	Pkg Qty
13-273	1/8 x Clo.	10
13-274	1/8 x 1-1/2	10
13-275	1/8 x 2	10
13-276	1/8 x 2-1/2	5
13-277	1/8 x 3	5
13-278	1/8 x 3-1/2	5
13-279	1/8 x 4	5
13-280	1/8 x 4-1/2	5
13-281	1/8 x 5	5
13-282	1/8 x 5-1/2	5
13-283	1/8 x 6	5
13-284	1/4 x Clo.	10
13-285	1/4 x 1-1/2	10
13-286	1/4 x 2	10
13-287	1/4 x 2-1/2	5
13-288	1/4 x 3	5
13-289	1/4 x 3-1/2	5
13-290	1/4 x 4	5
13-291	1/4 x 4-1/2	5
13-292	1/4 x 5	5
13-293	1/4 x 5-1/2	5
13-294	1/4 x 6	5
13-295	3/8 x Clo.	5
13-296	3/8 x 1-1/2	5
13-297	3/8 x 2	5
13-298	3/8 x 2-1/2	5
13-299	3/8 x 3	5
13-300	3/8 x 3-1/2	5
13-301	3/8 x 4	5
13-302	3/8 x 4-1/2	5
13-303	3/8 x 5	5
13-304	3/8 x 5-1/2	5
13-305	3/8 x 6	5

Part No.	Size	Pkg Qty
13-306	1/2 x Clo.	5
13-307	1/2 x 1-1/2	5
13-308	1/2 x 2	5
13-309	1/2 x 2-1/2	5
13-310	1/2 x 3	5
13-311	1/2 x 3-1/2	5
13-312	1/2 x 4	5
13-313	1/2 x 4-1/2	5
13-314	1/2 x 5	5
13-315	1/2 x 5-1/2	5
13-316	1/2 x 6	5
13-317	3/4 x Clo.	5
13-318	3/4 x 1-1/2	5
13-319	3/4 x 2	5
13-320	3/4 x 2-1/2	5
13-321	3/4 x 3	5
13-322	3/4 x 3-1/2	5
13-323	3/4 x 4	5
13-324	3/4 x 4-1/2	5
13-325	3/4 x 5	5
13-326	3/4 x 5-1/2	5
13-327	3/4 x 6	5

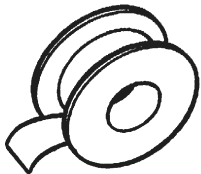

## Teflon<sup>®</sup> Pipe Tape

Part No.	Size	Pkg Qty
17-081	1/4" x 520"	50 RL
17-082	1/2" x 520"	50 RL
17-013	1/2" x 1296"	50 RL
17-083	3/4" x 520"	50 RL



**BRASS PIPE NIPPLE ASSORTMENT**  
20 SIZES, 1/8" TO 1/2" PIPE IN A LARGE  
STEEL DRAWER. **PART NO. 16-5824**

**Red Hot Deals!**

Check out our current specials  
and new items on our website at  
<http://www.mpi-online.com>



# Valves

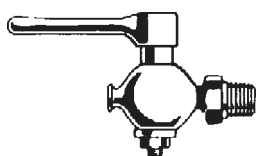

## Air Brake Drain Cock

- Lever handle • Male pipe thread
- Hex shoulder • Machined brass
- 120 psi max. • For truck air brakes

Part No.	Pipe Size	Pkg Qty
27-610 .....	1/4 .....	3

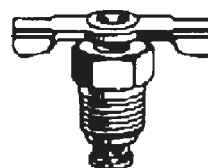

## External Seat Drain Cock

*Needle Drain Cock*

- Steel wing • Hex shoulder • Machined brass
- 150 psi max. • Most popular design for automotive radiators

Part No.	Pipe Size	Pkg Qty
27-623 .....	1/8 .....	10
27-624 .....	1/4 .....	10
27-625 .....	3/8 .....	3

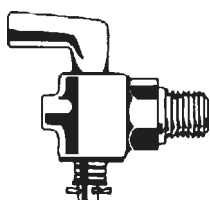

## Radiator Drain Valve

- Lever handle • Male Pipe Thread
- Hex shoulder • Cast Bronze • 15 psi max.
- For automotive radiator & industrial use

Part No.	Pipe Size	Pkg Qty
27-602 .....	1/4 .....	3



## Internal Seat Drain Cock

*Needle Drain Cock*

- Steel wing • Hex shoulder • Machined brass
- 150 psi max.

Part No.	Pipe Size	Pkg Qty
27-700 .....	1/8 .....	10
27-701 .....	1/4 .....	10

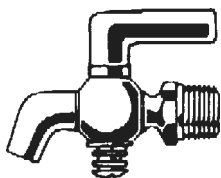

## Bibb Nose Air Cock

- Lever handle • Male Pipe Thread
- Hex shoulder • Machined brass • 80 psi max.
- For air use only

Part No.	Pipe Size	Pkg Qty
27-675 .....	1/8 .....	3
27-676 .....	1/4 .....	3
27-677 .....	3/8 .....	3
27-593 .....	1/2 .....	3



## Internal Seat Drain Cock

- Hex shoulder • All machined brass
- 150 psi max. • Handle is integral part of extruded stem

Part No.	Pipe Size	Pkg Qty
27-621 .....	1/4 .....	3
27-622 .....	3/8 .....	3



# Valves

## Tee Handle Air Cocks

Female pipe both ends. Round shoulders. Machined brass. Ground plug. 80 psi max. For air use only.

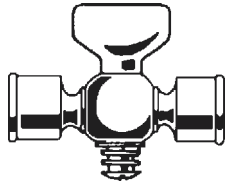

Part No.	Pipe Size	Pkg Qty
27-595	1/8	3
27-596	1/4	3
27-597	3/8	3

## Lever Handle Air Cocks

Female pipe both ends. Hex shoulders. Machined brass. Ground plug 80 psi max. For air use only.

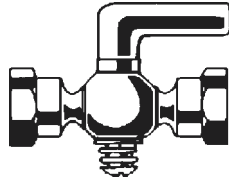

Part No.	Pipe Size	Pkg Qty
27-678	1/8	3
27-679	1/4	3
27-680	3/8	3

## Lever Handle Shut-Off Valve

Female pipe both ends. Hex shoulders. Cast bronze. Ground plug. 30 psi max. For air or water use (not for gas).

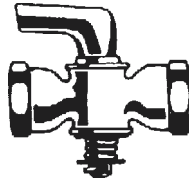

Part No.	Pipe Size	Pkg Qty
27-591	1/8	3
27-594	1/4	3
27-599	3/8	3
27-613	1/2	3

*Also available for natural gas service*

## Female Needle Valves

Female pipe both ends. Machined brass body, steel wing handle. 150 psi max. for water, oil or gasoline. Do not use with natural gas or LP gas

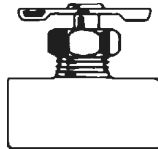

Part No.	Pipe Size	Pkg Qty
13-118	1/8	3
13-119	1/4	3

## Lever Handle Shut-Off Valve

Male pipe both ends. Hex shoulders. Cast bronze. Ground plug. 30 psi max. For air or water use (not for gas).

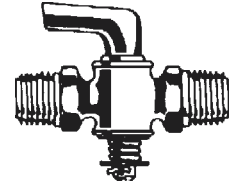

Part No.	Pipe Size	Pkg Qty
27-611	1/4	3
27-612	3/8	3

## Lever Handle Air Cock

Male pipe to female pipe. Hex shoulders. Machined brass. Ground plug. 80 psi max. For air use only.

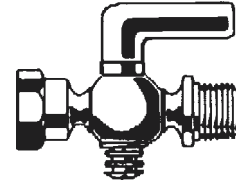

Part No.	Pipe Size	Pkg Qty
27-682	1/8	3
27-683	1/4	3
27-684	3/8	3

## Lever Handle Shut-Off Valve

Male pipe to female pipe. Hex shoulders. Cast bronze. Ground plug. 30 psi max. For air or water use.

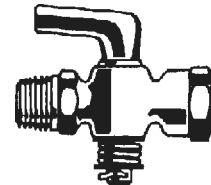

Part No.	Pipe Size	Pkg Qty
27-686	1/8	3
27-605	1/4	3

## Male Needle Valves

Male pipe both ends. Machined brass body, steel wing handle. 150 psi max. for water, oil or gasoline.

*Do not use with natural gas or LP gas*

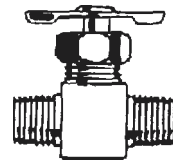

Part No.	Pipe Size	Pkg Qty
13-120	1/8	3
13-121	1/4	3

# Valves

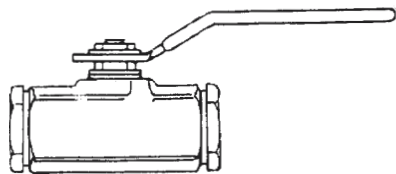

## Bronze Ball Valves

All cast bronze with Chrome plated ball. Teflon seat  
For water, oil, gas and air. Easy on-off with 90° quarter-  
turn lever handle.

DOMESTIC: Sizes to 1", 600 psi WOG, 150 psi saturated steam.  
1-1/4" to 2", 400 psi WOG, 125 psi saturated steam.

IMPORT: Lightweight, 450 psi WOG, 150 psi saturated steam.

Domestic Part No.	Import Part No.	Pipe Size	Pkg Qty
13-130•	13-102•	1/4	6
13-131•	13-103•	3/8	6
13-132•	13-104•	1/2	6
13-133•	13-105•	3/4	3
13-134•	13-106•	1"	3
13-135	13-107•	1-1/4	1
13-414	13-108•	1-1/2	1
13-415	13-109•	2"	1

• Part numbers marked have full ports.

## Safety Pop-Off Air Valves

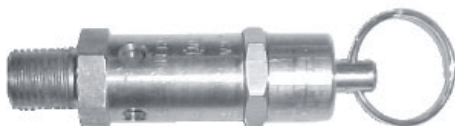

Designed to protect air tanks from overpressure. Maximum operating temperature is 250°F. All brass construction with chrome steel ball. 1/4" male NPT.

Part No.	Preset Pressure	Pkg Qty
11-366	100 psi	1
11-367	125 psi	1
11-368	150 psi	1
11-369	175 psi	1
11-370	200 psi	1

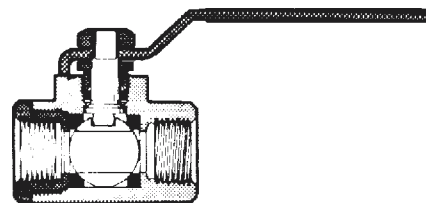

## Carbon Steel Ball Valves

Standard port. Female pipe both ends. 2,000 PSI for air, water, oil and gas. Made in U.S.A.

Part No.	Pipe Size	Pkg Qty
13-122	1/4	1
13-123	3/8	1
13-124	1/2	1
13-125	3/4	1
13-126	1"	1
13-127	1-1/4	1
13-128	1-1/2	1
13-129	2"	1

## Bronze Gate Valves

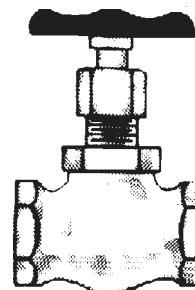

200 psi for water, oil or gas. 125 psi for saturated steam. Non-rising stem. Rugged cast bronze. Imported.

Part No.	Pipe Size	Pkg Qty
13-111	3/8	1
13-112	1/2	1
13-113	3/4	1
13-114	1"	1
13-115	1-1/4	1
13-116	1-1/2	1
13-117	2"	1



# Truck Heater Valves

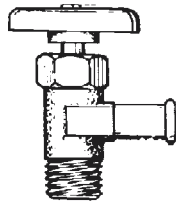

## Hose to Male Pipe

Part No.	Hose I.D.	Pipe Thread	Pkg Qty
27-614	3/8	3/8	1
27-615	5/8	3/8	1

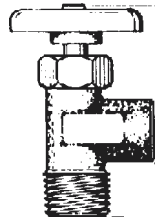

## Female Pipe to Male Pipe

Part No.	Hose I.D.	Pipe Thread	Pkg Qty
27-601	3/8	1/2	1

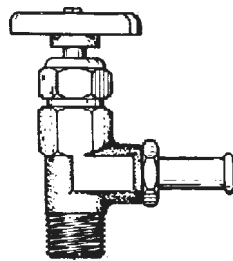

## Hose to Male Pipe

Part No.	Hose I.D.	Pipe Thread	Pkg Qty
27-616	5/8	1/2	1
27-617	3/4	1/2	1

VISIT OUR WEBSITE  
**mpi-online.com**  
 FAX ANYTIME!  
**219-696-6413**

# Schedule 40 Welded Steel Pipe Nipples

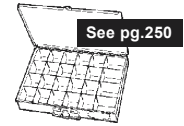

*Black fittings ideal for gas service. Galvanized fittings ideal for air, water and fluids. 150 psi, lightweight class 150.*

*NPT male both ends, chamfered threads. Meets ASTM A73, MIL-WW-P-521F, ANSI B-2.1, B-16.3. Made in U.S.A..*

Pipe Size	PART NUMBER		Pkg Qty
	Black	Galvanized	
1/8 x Clo.	11-206	10-224	12
1/8 x 1-1/2	11-207	10-225	12
1/8 x 2"	11-208	10-226	12
1/8 x 2-1/2	11-209	10-227	12
1/8 x 3"	11-210	10-228	12
1/8 x 3-1/2	11-211	10-229	6
1/8 x 4"	11-212	10-230	6
1/8 x 4-1/2	11-213	10-231	6
1/8 x 5"	11-214	10-232	6
1/8 x 5-1/2	11-215	10-233	6
1/8 x 6"	11-216	10-234	6
1/4 x Clo.	11-217	10-235	12
1/4 x 1-1/2	11-218	10-236	12
1/4 x 2"	11-219	10-237	12
1/4 x 2-1/2	11-220	10-238	12
1/4 x 3"	11-221	10-239	12
1/4 x 3-1/2	11-222	10-240	6
1/4 x 4"	11-223	10-241	6
1/4 x 4-1/2	11-224	10-242	6
1/4 x 5"	11-225	10-243	6
1/4 x 5-1/2	11-226	10-244	6
1/4 x 6"	11-227	10-245	6
3/8 x Clo.	11-228	10-247	12
3/8 x 1-1/2	11-229	10-248	12
3/8 x 2"	11-230	10-249	12
3/8 x 2-1/2	11-231	10-250	12
3/8 x 3"	11-232	10-251	12
3/8 x 3-1/2	11-233	10-252	6
3/8 x 4"	11-234	10-253	6
3/8 x 4-1/2	11-235	10-254	6
3/8 x 5"	11-236	10-255	6
3/8 x 5-1/2	11-237	10-256	6
3/8 x 6"	11-238	10-257	6

*Continued*

# Schedule 40 Welded Steel Pipe Nipples (Cont'd.)



Black fittings are ideal for gas service. Galvanized fittings are ideal for air, water and fluids. 150 psi, lightweight class 150. NPT male both ends, chamfered threads. Meets ASTM A73, MIL- WW-P-521F, ANSI B-2.1, B-16.3. Made in U.S.A..

Pipe Size	PART NUMBER		Pkg Qty
	Black	Galvanized	
1/2 x Clo.	11-241	10-258	12
1/2 x 1-1/2	11-242	10-259	12
1/2 x 2"	11-243	10-260	12
1/2 x 2-1/2	11-244	10-261	12
1/2 x 3"	11-245	10-262	12
1/4 x 3-1/2	11-246	10-263	6
1/2 x 4"	11-247	10-264	6
1/2 x 4-1/2	11-248	10-265	6
1/2 x 5"	11-249	10-266	6
1/2 x 5-1/2	11-250	10-267	6
1/2 x 6"	11-251	10-268	6
3/4 x Clo.	11-255	10-271	12
3/4 x 1-1/2	11-256	10-272	12
3/4 x 2"	11-257	10-273	12
3/4 x 2-1/2	11-258	10-274	12
3/4 x 3"	11-259	10-275	12
3/4 x 3-1/2	11-260	10-276	6
3/4 x 4"	11-261	10-277	6
3/4 x 4-1/2	11-262	10-278	6
3/4 x 5"	11-263	10-279	6
3/4 x 5-1/2	11-264	10-280	6
3/4 x 6"	11-265	10-281	6
1" x Clo.	11-266	10-284	6
1" x 2"	11-267	10-285	6
1" x 2-1/2	11-268	10-286	6
1" x 3"	11-269	10-287	6
1" x 3-1/2	11-270	10-288	3
1" x 4"	11-271	10-289	3
1" x 4-1/2	11-272	10-290	3
1" x 5"	11-273	10-291	3
1" x 5-1/2	11-274	10-292	3
1" x 6"	11-275	10-293	3

Pipe Size	PART NUMBER		Pkg Qty
	Black	Galvanized	
1-1/4 x Clo.	11-276	10-294	1
1-1/4 x 2"	11-277	10-295	1
1-1/4 x 2-1/2	11-278	10-296	1
1-1/4 x 3"	11-279	10-297	1
1-1/4 x 3-1/2	11-280	10-298	1
1-1/4 x 4"	11-281	10-299	1
1-1/4 x 4-1/2	11-282	10-300	1
1-1/4 x 5"	11-283	10-301	1
1-1/4 x 5-1/2	11-284	10-302	1
1-1/4 x 6"	11-285	10-303	1
1-1/2 x Clo.	11-287	10-304	1
1-1/2 x 2"	11-288	10-305	1
1-1/2 x 2-1/2	11-289	10-306	1
1-1/2 x 3"	11-290	10-307	1
1-1/2 x 3-1/2	11-291	10-308	1
1-1/2 x 4"	11-292	10-309	1
1-1/2 x 4-1/2	11-293	10-310	1
1-1/2 x 5"	11-294	10-311	1
1-1/2 x 5-1/2	11-295	10-312	1
1-1/2 x 6"	11-296	10-313	1
2" x Clo.	11-297	10-314	1
2" x 2-1/2	11-298	10-315	1
2" x 3"	11-299	10-316	1
2" x 3-1/2	11-300	10-317	1
2" x 4"	11-301	10-318	1
2" x 4-1/2	11-302	10-319	1
2" x 5"	11-303	10-320	1
2" x 5-1/2	11-304	10-321	1
2" x 6"	11-305	10-322	1
3" x Clo.	11-163	10-181	1
3" x 4"	11-166	10-184	1
3" x 5"	11-168	10-186	1
3" x 6"	11-170	10-188	1

## Teflon® Pipe Tape



Part No.	Size	Pkg Qty
17-081	1/4" x 520"	50 RL
17-082	1/2" x 520"	50 RL
17-013	1/2" x 1296"	50 RL
17-083	3/4" x 520"	50 RL



Manufactured in the U.S.A.



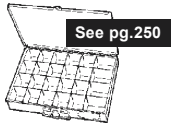

# 150# Malleable Iron Pipe Fittings



## 90° Elbows

MIL- WW-P-521F, A.N.S.I B-2.1 (threads), B-16.3

Pipe Size	PART NUMBER		Pkg Qty
	Black	Galvanized	
1/8	11-000	10-000	12
1/4	11-001	10-001	12
3/8	11-002	10-002	12
1/2	11-003	10-003	12
3/4	11-004	10-004	6
1"	11-005	10-005	6
1-1/4	11-006	10-006	1
1-1/2	11-007	10-007	1
2"	11-008	10-008	1
2-1/2	11-009	10-009	1
3"	11-010	10-010	1



## 90° Street Elbow

MIL- WW-P-521F, A.N.S.I B-2.1 (threads), B-16.3

Pipe Size	PART NUMBER		Pkg Qty
	Black	Galvanized	
1/8	11-020	10-020	6
1/4	11-021	10-021	6
3/8	11-022	10-022	6
1/2	11-023	10-023	6
3/4	11-024	10-024	6
1"	11-025	10-025	3
1-1/4	11-026	10-026	1
1-1/2	11-027	10-027	1
2"	11-028	10-028	1
2-1/2	11-029	10-029	1
3"	11-030	10-030	1



## 45° Elbow

MIL- WW-P-521F, A.N.S.I B-2.1 (threads), B-16.3

Pipe Size	PART NUMBER		Pkg Qty
	Black	Galvanized	
1/8	11-011	10-011	12
1/4	11-012	10-012	12
3/8	11-013	10-013	12
1/2	11-014	10-014	12
3/4	11-015	10-015	6
1"	11-016	10-016	6
1-1/4	11-017	10-017	6
1-1/2	11-018	10-018	1
2"	11-019	10-019	1
2-1/2	11-339	10-325	1
3"	11-340	10-326	1



## 45° Street Elbows

MIL- WW-P-521F, A.N.S.I B-2.1 (threads), B-16.3

Pipe Size	PART NUMBER		Pkg Qty
	Black	Galvanized	
1/8	11-031	10-031	6
1/4	11-032	10-032	6
3/8	11-033	10-033	6
1/2	11-034	10-034	6
3/4	11-035	10-035	6
1"	11-036	10-036	3
1-1/4	11-037	10-037	1
1-1/2	11-038	10-038	1
2"	11-039	10-039	1

**SAVE WHEN YOU  
BUY IN QUANTITY!**



Manufactured in the U.S.A.

# 150# Malleable Iron Pipe Fittings

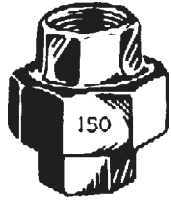

## Unions

MIL- WW-U-531C

Pipe Size	PART NUMBER		Pkg Qty
	Black	Galvanized	
1/8	11-048	10-049	6
1/4	11-049	10-050	6
3/8	11-050	10-051	6
1/2	11-051	10-052	6
3/4	11-052	10-053	6
1"	11-053	10-054	3
1-1/4	11-054	10-055	1
1-1/2	11-055	10-056	1
2"	11-056	10-057	1



## Pipe Couplings\*

MIL- WW-P471B

Pipe Size	PART NUMBER		Pkg Qty
	Black	Galvanized	
1/8	11-065	10-061	12
1/4	11-066	10-062	12
3/8	11-067	10-063	12
1/2	11-068	10-064	12
3/4	11-069	10-065	6
1"	11-070	10-066	6
1-1/4	11-071	10-067	2
1-1/2	11-072	10-068	2
2"	11-073	10-069	2
2-1/2	11-074	10-070	1
3"	11-075	10-071	1

\*Furnished in steel.

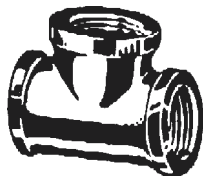

## Pipe Tees

MIL- WW-P-521F, A.N.S.I B-2.1 (threads), B-16.3

Pipe Size	PART NUMBER		Pkg Qty
	Black	Galvanized	
1/8	11-077	10-072	6
1/4	11-078	10-073	6
3/8	11-079	10-074	6
1/2	11-080	10-075	6
3/4	11-081	10-076	6
1"	11-082	10-077	3
1-1/4	11-083	10-078	1
1-1/2	11-084	10-079	1
2"	11-085	10-080	1
2-1/2	11-086	10-081	1
3"	11-087	10-082	1

## The Sun

This yellow dwarf star provides the Earth with 126,000,000,000,000 horsepower of energy each day. 54,000 horsepower for every man, woman and child every 24 hours.

A person weighing 150 pounds on Earth would weigh 2 tons on the sun because of the sun's gravity.

As the sun shines it loses mass at a rate of about 4 million tons per second, but the volume of the sun is so enormous that it is not expected to expand into a red giant for at least another 8 billion years.



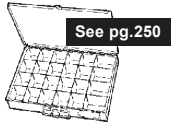

# 150# Malleable Iron Pipe Fittings



## Reducers

MIL- WW-P-521F, A.N.S.I B-2.1 (threads), B-16.3

Pipe Size	PART NUMBER		Pkg Qty
	Black	Galvanized	
1/4 x 1/8	11-171	10-189	12
3/8 x 1/8	11-172	10-190	12
3/8 x 1/4	11-173	10-191	12
1/2 x 1/8	11-174	10-192	12
1/2 x 1/4	11-175	10-193	12
1/2 x 3/8	11-176	10-194	12
3/4 x 1/8	11-177	10-195	6
3/4 x 1/4	11-178	10-196	6
3/4 x 3/8	11-179	10-197	6
3/4 x 1/2	11-180	10-198	6
1" x 1/2	11-184	10-202	6
1" x 3/4	11-185	10-203	6
1-1/4 x 1/2	11-188	10-206	1
1-1/4 x 3/4	11-189	10-207	1
1-1/4 x 1"	11-190	10-208	1
1-1/2 x 1-1/4	11-195	10-213	1
2" x 1-1/2	11-200	10-218	1

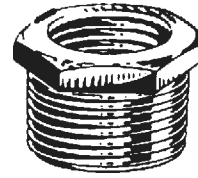

## Machined Steel Hex Bushings

MIL- WW-P471B

Pipe Size	PART NUMBER		Pkg Qty
	Black	Zinc Plated	
1/4 x 1/8	11-125*	10-140*	12
3/8 x 1/8	11-126*	10-141*	12
3/8 x 1/4	11-127*	10-142*	12
1/2 x 1/8	11-128*	10-143*	12
1/2 x 1/4	11-129*	10-144*	12
1/2 x 3/8	11-130*	10-145*	12
3/4 x 1/8	11-131*	10-146*	12
3/4 x 1/4	11-132*	10-147*	12
3/4 x 3/8	11-133*	10-148*	12
3/4 x 1/2	11-134*	10-149*	12
1" x 3/8	11-137*	10-152*	6
1" x 1/2	11-138*	10-153*	6
1" x 3/4	11-139*	10-154*	6
1-1/4 x 1/2	See below	10-157*	1
1-1/4 x 3/4	See below	10-158*	1
1-1/4 x 1"	See below	10-159*	1

## Cast Iron Hex Bushings

MIL- WW-P471B

Pipe Size	PART NUMBER		Pkg Qty
	Black	Galvanized	
1-1/4 x 1/2	11-142	See above	1
1-1/4 x 3/4	11-143	See above	1
1-1/4 x 1"	11-144	See above	1
1-1/2 x 1/2	11-147	10-162	1
1-1/2 x 3/4	11-148	10-163	1
1-1/2 x 1"	11-149	10-164	1
1-1/2 x 1-1/4	11-150	10-165	1
2" x 1/2	11-152	10-167	1
2" x 3/4	11-153	10-168	1
2" x 1"	11-154	10-169	1
2" x 1-1/4	11-155	10-170	1
2" x 1-1/2	11-156	10-171	1
2-1/2 x 2"	11-159	10-344	1
3" x 2"	11-160	10-350	1

\*Furnished in steel.



## Machined Steel Pipe Caps

MIL- WW-P471B

Pipe Size	PART NUMBER		Pkg Qty
	Black	Zinc Plated	
1/8	11-088*	10-090*	12
1/4	11-089*	10-091*	12
3/8	11-090*	10-092*	12
1/2	11-091*	10-093*	12
3/4	11-092*	10-094*	6
1"	11-093*	10-095*	6

## Cast Iron Pipe Caps

MIL- WW-P471B

Pipe Size	PART NUMBER		Pkg Qty
	Black	Galvanized	
1-1/4	11-094	10-096	1
1-1/2	11-095	10-097	1
2"	11-096	10-098	1
2-1/2	11-097	10-099	1
3"	11-098	10-100	1

VISIT OUR WEBSITE  
**mpi-online.com**  
 FAX ANYTIME!  
**219-696-6413**



# 150# Malleable Iron Pipe Fittings



## Machined Steel Square Head Plugs

MIL- WW-P471B

Pipe Size	PART NUMBER		Pkg Qty
	Black	Zinc Plated	
1/8	11-099*	10-101*	12
1/4	11-100*	10-102*	12
3/8	11-101*	10-103*	12
1/2	11-102*	10-104*	12
3/4	11-103*	10-105*	12

## Cast Iron Square Head Plugs

MIL- WW-P471B

Pipe Size	PART NUMBER		Pkg Qty
	Black	Galvanized	
1"	11-104	10-106	6
1-1/4	11-105	10-107	6
1-1/2	11-106	10-108	6
2"	11-107	10-109	3
2-1/2	11-325	10-110	1
3"	11-326	10-111	1

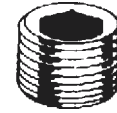

## Machined Steel Countersunk Plugs

Pipe Size	Style	PART NUMBER		Pkg Qty
		Black	Galv.	
1/8	Hex	11-113*	10-121*	12
1/4	Hex	11-114*	10-122*	12
3/8	Hex	11-115*	10-123*	12
1/2	Hex	11-116*	10-124*	12
3/4	Hex	11-117*	10-125*	6



## Cast Iron Countersunk Plugs

MIL- WW-P471B

Pipe Size	Style	PART NUMBER		Pkg Qty
		Black	Galv.	
1"	Square	11-118	10-363	6
1-1/4	Square	11-327	10-364	2
1-1/2	Square	11-328	10-365	2
2"	Square	11-329	10-366	2



## Steel Hex Head Plugs

MIL- WW-P471B

Pipe Size	PART NUMBER		Pkg Qty
	Black	Zinc Plated	
1/8	11-108	10-112	12
1/4	11-109	10-113	12
3/8	11-110	10-114	12
1/2	11-111	10-115	12
3/4	11-112	10-116	6
1"	11-356	10-117	6



## Dry-Seal Socket Pressure Plugs

Precision machined 7/8" taper keeps plug flush with surface and creates a leakproof seal without using sealing tape or compound. Made from heat treated alloy steel. Deep hex countersink. Pressure rating is 5,000 PSI. Plain finish. ASTM A574, ANSI B1.20.3.

Pipe Size	Part No.	Pkg Qty
1/16	12-299	12
1/8	12-300	12
1/4	12-301	12
3/8	12-302	12
1/2	12-303	12
3/4	12-304	6
1"	12-305	6



Manufactured in the U.S.A.



# 150# Malleable Iron Pipe Fittings Assortments

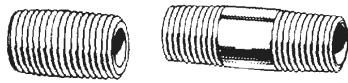

## Pipe Nipple Assortments



### BLACK PIPE NIPPLE ASSORTMENT

20 SIZES, 1/8" TO 1/2" PIPE IN A LARGE STEEL DRAWER.  
PART NO. 16-5624

### GALVANIZED PIPE NIPPLE ASSORTMENT

20 SIZES, 1/8" TO 1/2" PIPE IN A LARGE STEEL DRAWER.  
PART NO. 16-5724

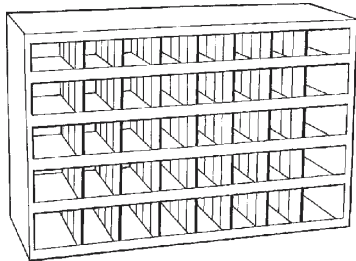

### BLACK PIPE NIPPLE ASSORTMENT

35 SIZES, 1/8" TO 3/4" PIPE IN A 40-HOLE BIN.  
PART NO. 40-109

### BLACK PIPE NIPPLE ASSORTMENT

(LARGE SIZES) 24 SIZES, 1" TO 2" PIPE IN  
A 40-HOLE BIN. PART NO. 40-119

### GALVANIZED PIPE NIPPLE ASSORTMENT

35 SIZES, 1/8" TO 3/4" PIPE IN A 40-HOLE BIN.  
PART NO. 40-110

### GALVANIZED PIPE NIPPLE ASSORTMENT

(LARGE SIZES) 24 SIZES, 1" TO 2" PIPE IN  
A 40-HOLE BIN. PART NO. 40-120



## Pipe Fitting Assortments



### BLACK PIPE FITTING ASSORTMENT

28 SIZES, 1/8" TO 1/2" PIPE IN A LARGE STEEL DRAWER.  
PART NO. 16-5632

### GALVANIZED PIPE FITTING ASSORTMENT

28 SIZES, 1/8" TO 1/2" PIPE IN A LARGE STEEL DRAWER.  
PART NO. 16-5732

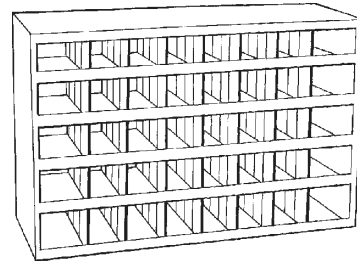

### BLACK PIPE FITTING ASSORTMENT

34 SIZES, 1/8" TO 3/4" PIPE IN A 40-HOLE BIN.  
PART NO. 40-108

### BLACK PIPE FITTING ASSORTMENT

(LARGE SIZES) 28 SIZES, 1" TO 2" PIPE IN  
A 40-HOLE BIN. PART NO. 40-117

### GALVANIZED PIPE FITTING ASSORTMENT

34 SIZES, 1/8" TO 3/4" PIPE IN A 40-HOLE BIN.  
PART NO. 40-107

### GALVANIZED PIPE FITTING ASSORTMENT

(LARGE SIZES) 28 SIZES, 1" TO 2" PIPE IN  
A 40-HOLE BIN. PART NO. 40-118

# Air Brake Hose Fittings

Reusable hose ends. For use with 3/8" Rubber Air Brake Hose.

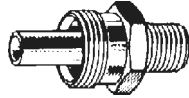

## Connector Body (Insert)

Part No.	Pipe Thread	Pkg
5510 .....	1/4 .....	5
5511 .....	3/8 .....	5
5512 .....	1/2 .....	5



## Union

Part No.	Pkg
5509 .....	2



## Hose Connector

Part No.	Pipe Thread	Pkg
5503 .....	1/4 .....	5
5504 .....	3/8 .....	5
5505 .....	1/2 .....	5



## Sleeve

Part No.	Pkg
5508 .....	10

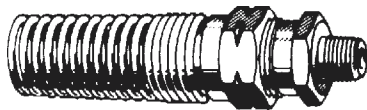

## Hose Connector with Spring Guard

Part No.	Pipe Thread	Pkg
5500 .....	1/4 .....	5
5501 .....	3/8 .....	5
5502 .....	1/2 .....	5



## Hose Nut

Part No.	Pkg
5506 .....	10

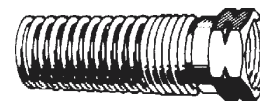

## Nut with Spring Guard

Part No.	Pkg
5507 .....	5

VISIT OUR WEBSITE  
[mpi-online.com](http://mpi-online.com)  
 FAX ANYTIME!  
**219-696-6413**



# Airbrake Replacement Parts

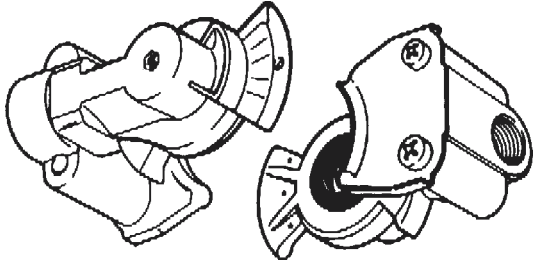

## Glad Hands

(Air Brake Hose Couplings)

Connects to 1/2" pipe. Universal glad hands will connect to all three styles.

### CAST IRON

Part No.	Application	Pkg
5513	Universal, Heavy Duty	1

### ALUMINUM

Part No.	Application	Pkg
5514	Emergency	1
5515	Service	1
5516	Universal	1



## Air Brake Diaphragms

Pancakes. Clamp type.

Part No.	Chamber Type	Dia.	Pkg Qty
03-302	12	5 1/2"	6
03-303	16	6"	6
03-304	24	7"	6
03-305	30	8"	6

## Glad Hand Seals

(Rubbers)

### DOUBLE LIP

Part No.	Pkg
5518	25

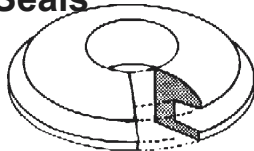

### STANDARD

Part No.	Pkg
5517	25

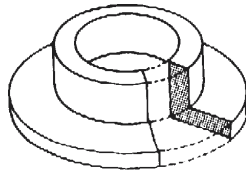

## Air Brake Hose Assemblies

One male fixed end and one female swivel end with male adapter (brass). Meets S.A.E. J1402 Type B specifications.

Part No.	Hose I.D.	Length	Thrd. Size	Pkg Qty
4826	3/8	24"	1/4 npt	1
4827	3/8	30"	1/4 npt	1
4828	3/8	36"	1/4 npt	1
4829	3/8	48"	1/4 npt	1

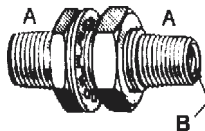

## Clamping Studs

Steel Bulkhead Unions

Part No.	Pipe Thread A	Pipe Thread B	Pkg Qty
5519	1/2	1/4	6



# Industrial 1/4" Series Quick Disconnect Couplers & Nipples

*Couplers are valved to avoid pressure loss when disconnected.  
Couplers and Nipples are made of steel, except where marked.  
To connect; pull back sleeve, insert nipple and release sleeve.  
300 psi max. working pressure.*

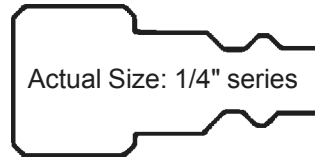

**1/4" Series  
MALE PIPE COUPLERS**

Part No.	Pipe Size	Pkg Qty
5556 .....	1/4 .....	6
5557 .....	3/8 .....	6

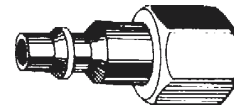

**1/4 Series  
FEMALE PIPE THREAD NIPPLES**

Part No.	Pipe Size	Pkg Qty
5575 .....	1/4 .....	6
5576 .....	3/8 .....	6

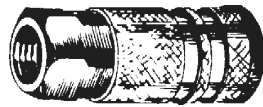

**1/4" Series  
FEMALE PIPE COUPLERS**

Part No.	Pipe Size	Pkg Qty
5550* .....	1/4 .....	6
5551* .....	3/8 .....	6

*\* Brass body & sleeve*

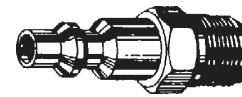

**1/4 Series  
MALE PIPE THREAD NIPPLES**

Part No.	Pipe Size	Pkg Qty
5581 .....	1/4 .....	6
5582 .....	3/8 .....	6



**INDUSTRIAL COUPLER/NIPPLE SET**  
ONE 5550 COUPLER AND  
ONE 5581NIPPLE. PKG: 1 SET  
**PART NO. 5550-2**



**1/4" Series  
HOSE BARB COUPLERS**

Part No.	Hose I.D. Size	Pkg Qty
5562 .....	1/4 .....	6
5563 .....	3/8 .....	6



**1/4" Series  
HOSE BARB NIPPLES**

Part No.	Hose I.D. Size	Pkg Qty
5587 .....	1/4 .....	6
5588 .....	3/8 .....	6



# Industrial 3/8" Series Quick Disconnect Couplers & Nipples

*Couplers are valved to avoid pressure loss when disconnected.  
Couplers and Nipples are made of steel.  
To connect; pull back sleeve, insert nipple and release sleeve.  
300 psi max. working pressure.*

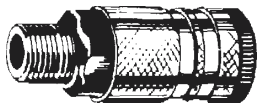
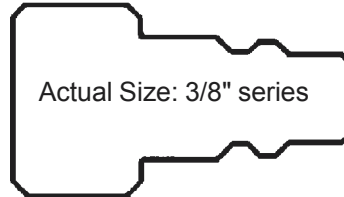

**3/8 Series  
MALE PIPE COUPLERS**

Part No.	Pipe Size	Pkg Qty
5558	1/4	2
5559	3/8	2

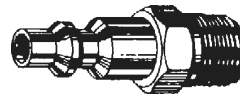

**3/8 Series  
MALE PIPE THREAD NIPPLES**

Part No.	Pipe Size	Pkg Qty
5583	1/4	2
5584	3/8	2

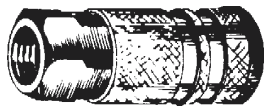

**3/8 Series  
FEMALE PIPE COUPLERS**

Part No.	Pipe Size	Pkg Qty
5552	1/4	2
5553	3/8	2

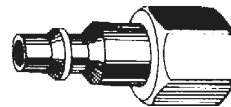

**3/8 Series  
FEMALE PIPE THREAD NIPPLES**

Part No.	Pipe Size	Pkg Qty
5577	1/4	2
5578	3/8	2



**3/8 Series  
HOSE BARB COUPLERS**

Part No.	Hose I.D. Size	Pkg Qty
5564	3/8	2



**3/8" Series  
HOSE BARB NIPPLES**

Part No.	Hose I.D. Size	Pkg Qty
5590	3/8	2

# Industrial 1/2" Series Quick Disconnect Couplers & Nipples

*Couplers are valved to avoid pressure loss when disconnected.  
Couplers and Nipples are made of steel.  
To connect; pull back sleeve, insert nipple and release sleeve.  
300 psi max. working pressure.*

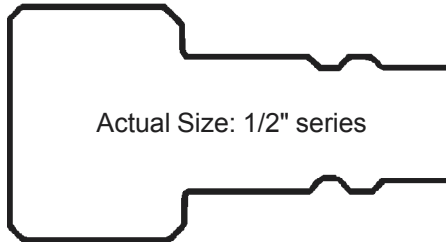

**1/2" Series  
MALE PIPE COUPLERS**

Part No.	Pipe Size	Pkg Qty
5560 .....	1/2 .....	2

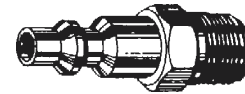

**1/2" Series  
MALE PIPE THREAD NIPPLES**

Part No.	Pipe Size	Pkg Qty
5585 .....	1/2 .....	2

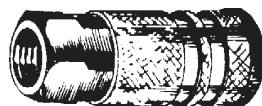

**1/2" Series  
FEMALE PIPE COUPLERS**

Part No.	Pipe Size	Pkg Qty
5554 .....	1/2 .....	2

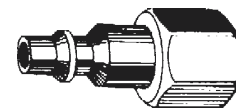

**1/2" Series  
FEMALE PIPE THREAD NIPPLES**

Part No.	Pipe Size	Pkg Qty
5579 .....	1/2 .....	2

A lie can travel halfway around the world  
while the truth is putting on its shoes.

-Mark Twain



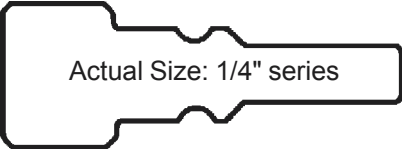

# Lincoln 1/4" Series

## Quick Disconnect Couplers & Nipples

*Couplers are valved to avoid pressure loss when disconnected. Couplers have brass sleeves and bodies. Nipples are made of steel. To connect; pull back sleeve, insert nipple and release sleeve. 300 psi max. working pressure.*



**1/4 series  
MALE PIPE COUPLER**

Part No.	Pipe Size	Pkg Qty
5613	1/4	6



**1/4 series  
MALE PIPE NIPPLE**

Part No.	Pipe Size	Pkg Qty
5615	1/4	6



**1/4 series  
FEMALE PIPE COUPLER**

Part No.	Pipe Size	Pkg Qty
5612	1/4	6

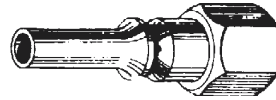

**1/4 series  
FEMALE PIPE NIPPLE**

Part No.	Pipe Size	Pkg Qty
5614	1/4	6

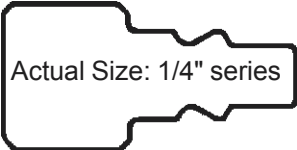

# Aro 210 1/4" Series

## Quick Disconnect Couplers & Nipples

*Made of steel. 300 psi max. working pressure.*



**1/4 series  
FEMALE PIPE COUPLER**

Part No.	Pipe Size	Pkg Qty
5616	1/4	6

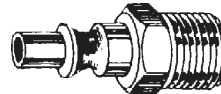

**1/4 series  
MALE PIPE NIPPLE**

Part No.	Pipe Size	Pkg Qty
5619	1/4	6



**1/4 series  
MALE PIPE COUPLER**

Part No.	Pipe Size	Pkg Qty
5617	1/4	6

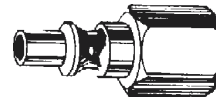

**1/4 series  
FEMALE PIPE NIPPLE**

Part No.	Pipe Size	Pkg Qty
5618	1/4	6



# Tru-flate

## Quick Disconnects & Nipples

Couplers are valved to avoid pressure loss when disconnected. Couplers have brass sleeves and bodies, except where marked. Nipples are made of steel. To connect; pull back sleeve, insert nipple and release sleeve. 300 psi max. working pressure.

Actual size:

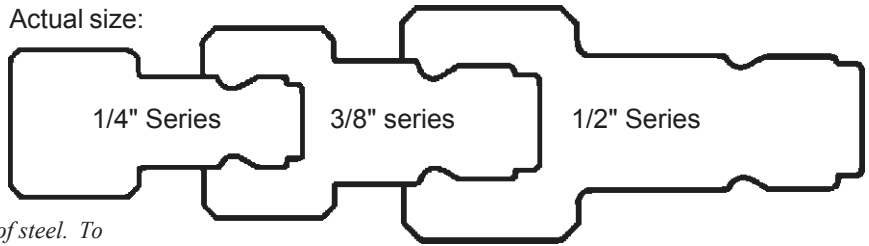

### MALE PIPE COUPLERS

Part No.	Pipe Size	Pkg Qty
5603	1/4	6



### FEMALE PIPE COUPLERS

Part No.	Pipe Size	Pkg Qty
5600	1/4	6



### MALE PIPE THREAD NIPPLES

Part No.	Pipe Size	Pkg Qty
5609	1/4	6



### FEMALE PIPE THREAD NIPPLES

Part No.	Pipe Size	Pkg Qty
5606	1/4	6

## 3/8" SERIES



### MALE PIPE COUPLERS

Part No.	Pipe Size	Pkg Qty
5604	3/8	2



### FEMALE PIPE COUPLERS

Part No.	Pipe Size	Pkg Qty
5601	3/8	2



### MALE PIPE THREAD NIPPLES

Part No.	Pipe Size	Pkg Qty
5610	3/8	2



### FEMALE PIPE THREAD NIPPLES

Part No.	Pipe Size	Pkg Qty
5607	3/8	2

## 1/2" SERIES



### MALE PIPE COUPLERS

Part No.	Pipe Size	Pkg Qty
5560*	1/2	2

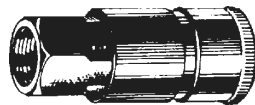

### FEMALE PIPE COUPLERS

Part No.	Pipe Size	Pkg Qty
5554*	1/2	2



### MALE PIPE THREAD NIPPLES

Part No.	Pipe Size	Pkg Qty
5611	1/2	2



### FEMALE PIPE THREAD NIPPLES

Part No.	Pipe Size	Pkg Qty
5608	1/2	2

\* Steel sleeve and body.



# Push To Connect Air Couplers

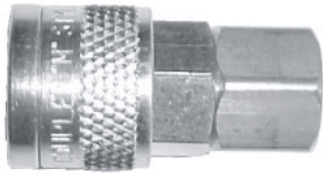

Automatically connected by pushing the nipple into the coupler. When the outer sleeve moves forward, the coupler is automatically locked into place and is ready for use. To disconnect, just pull the sleeve back and remove nipple. Air flow stops when plug is removed. Unique slim design prevents accidental disconnect when used on end of flexible air lines. Made of brass. Conforms to MIL-4109 specifications. 300 psi max. working pressure.

## FEMALE PIPE COUPLERS

Part No.	Pipe Size	Pkg Qty
11-313 .....	1/4 .....	2

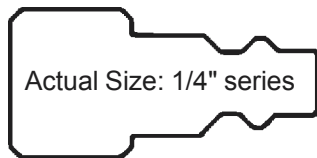

# Nylon Coil Air Hose

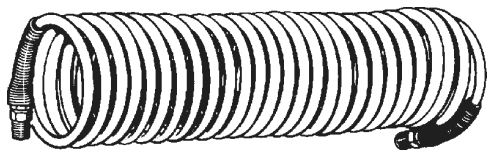

Withstands working pressure up to 200 PSI Recoils to a fraction of its full length to return tool to safe location. 1/4" swivel male NPT both ends.

Part No.	Hose Size	Pkg
4830 .....	1/4 I.D. x 17' .....	1
4831 .....	1/4 I.D. x 25' .....	1
4832 .....	1/4 I.D. x 50' .....	1
4833 .....	3/8 I.D. x 17' .....	1
4834 .....	3/8 I.D. x 25' .....	1
4835 .....	3/8 I.D. x 50' .....	1

# Straight-Thru Couplers & Nipples



## NO VALVES

Smooth, straight thru bore gives maximum flow with minimum pressure drop. Applications: pressure washers, steam washers, carpet cleaners, air lines, mold coolant lines, fluid transfer lines. Open bore allows complete clean-ability. *Warning: Do not disconnect with pressure in the line.*

## STRAIGHT THRU COUPLERS

*Brass with stainless steel balls and springs.*

Part No.	Series	Pipe Size	Operating PSI	Pkg Qty
11-311 .....	1/4" .....	1/4 Female .....	4500 .....	6
11-371 .....	3/8" .....	3/8 Female .....	3500 .....	6
11-372 .....	3/8" .....	3/8 Male .....	3500 .....	6

## STRAIGHT THRU NIPPLES

*Zinc plated hardened steel.*

Part No.	Series	Pipe Size	Operating PSI	Pkg Qty
11-312 .....	1/4" .....	1/4 Male .....	4500 .....	6
11-373 .....	3/8" .....	3/8 Female .....	3500 .....	6
11-374 .....	3/8" .....	3/8 Male .....	3500 .....	6

Actual size:

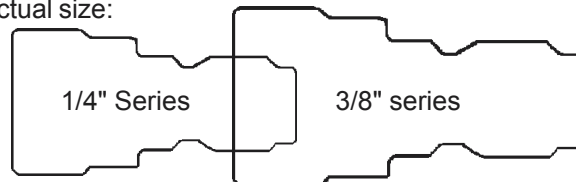

# 60 Series Hydraulic Couplers

The 60 series industrial interchange couplers incorporate valves in both the body and nipple halves to minimize fluid loss when the coupling is disconnected. These couplings are normally referred to as “hydraulic couplings”, but they are used extensively with other media where fluid loss on disconnect is objectionable. The 60 Series couplers are dimensionally and operationally interchangeable with most major brands of the same size, such as Parker (60 series), Aeroquip (FD45 series), Hansen (HK series), Foster and others.

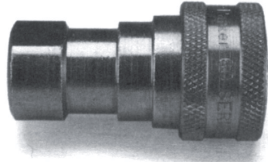

## 60 SERIES COUPLERS

Pkg. Qty. 1 each

Part No.	Body Size	Pipe Size	Material	Pressure Rating
5620	1/4	1/4 NPTF	Steel	5000 psi
5621	3/8	3/8 NPTF	Steel	4000 psi
5622	1/2	1/2 NPTF	Steel	4000 psi
5623	3/4	3/4 NPTF	Steel	2500 psi

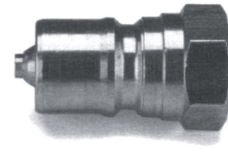

## 60 SERIES NIPPLES

Pkg. Qty. 1 each

Part No.	Body Size	Pipe Size	Material	Pressure Rating
5628	1/4	1/4 NPTF	Steel	5000 psi
5629	3/8	3/8 NPTF	Steel	4000 psi
5630	1/2	1/2 NPTF	Steel	4000 psi
5631	3/4	3/4 NPTF	Steel	2500 psi

### ACTUAL SIZE PROFILE

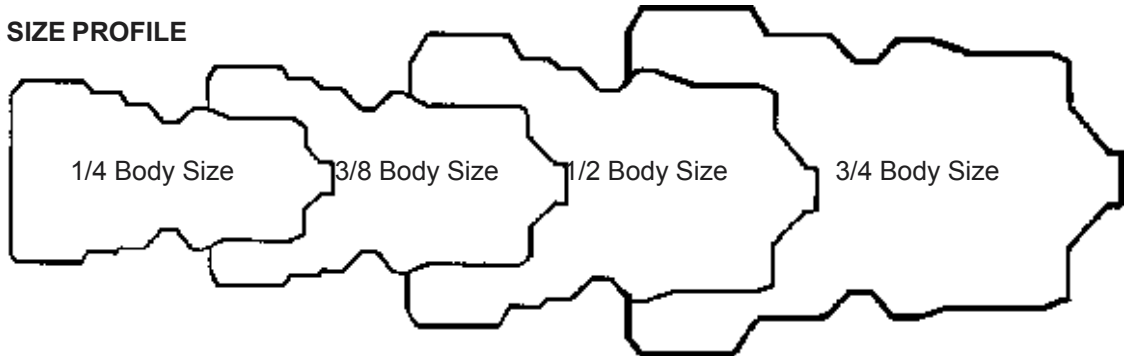

## Dust Plugs

Part No.	Series	Body Size	Material	Pkg Qty
11-314	60	1/4	Polyurethane	1
11-315	60	3/8	Polyurethane	1
11-316	60	1/2	Polyurethane	1
11-365	60	3/4	Polyurethane	1



## Dust Caps

Part No.	Series	Body Size	Material	Pkg Qty
11-317	60	1/4	Polyurethane	1
11-318	60	3/8	Polyurethane	1
11-319	60	1/2	Polyurethane	1
11-364	60	3/4	Polyurethane	1



# Pioneer 4000 Series Hydraulic Couplers

The 4000 Series (standard to agricultural industry) features precision steel balls and machining to insure a tight metal to metal seal. Critical parts are induction hardened for long life. Buna N body seal. Exceptional dependability for demanding hydraulic applications. The Pioneer 4000 series is interchangeable with most Safeway models. Available in a wide range of sizes from 1/4" to 1".

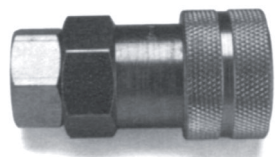

## 4000 SERIES COUPLERS

Pkg. Qty. 1 each

Part No.	Body Size	Pipe Size	Material	Pressure Rating
5636	1/4	1/4 NPTF	Steel	2000 psi
5638	3/8	3/8 NPTF	Steel	2500 psi
5640	1/2	1/2 NPTF	Steel	2500 psi

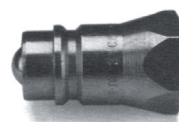

## 4000 SERIES NIPPLES

Pkg. Qty. 1 each

Part No.	Body Size	Pipe Size	Material	Pressure Rating
5637	1/4	1/4 NPTF	Steel	2000 psi
5639	3/8	3/8 NPTF	Steel	2500 psi
5641	1/2	1/2 NPTF	Steel	2500 psi

# Pioneer 5000 Series Hydraulic Couplers

Connect or disconnect under pressure. Rated pressure 2200 psi. 5000 Series is an economical coupling for applications where uncoupling or recoupling under trapped pressure is a requirement. This is simply accomplished with ordinary wrenches. No remote valve required.

## 5000 SERIES COUPLERS

Pkg. Qty. 1 each

Part No.	Body Size	Pipe Size	Material	Pressure Rating
5642	1/2	1/2 NPTF	Steel	2200 psi

## 5000 SERIES NIPPLES

Pkg. Qty. 1 each

Part No.	Body Size	Pipe Size	Material	Pressure Rating
5641	1/2	1/2 NPTF	Steel	2200 psi

4000 & 5000 SERIES  
ACTUAL SIZE PROFILE

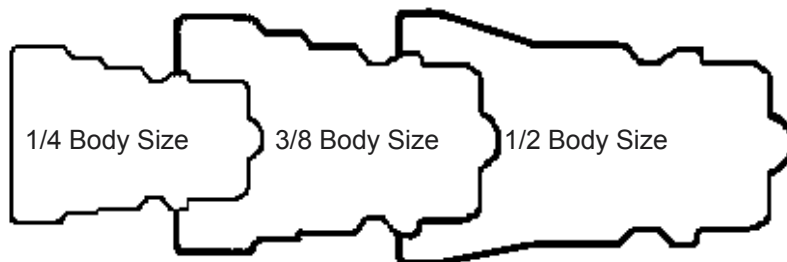

## Dust Plugs

Part No.	Series	Body Size	Material	Pkg Qty
11-320	4000	1/4	Rubber	1
11-321	4000	3/8	Rubber	1
11-322	4000, 5000	1/2	Rubber	1



## Dust Caps

Part No.	Series	Body Size	Material	Pkg Qty
11-323	4000	1/4	Rubber	1
11-324	4000	3/8	Rubber	1
11-330	4000, 5000	1/2	Rubber	1

# 6600 Series Hydraulic Couplers

Double shutoff design for use where frequent connections and disconnections are made. Two-way check valves in both coupler and nipple provides instant shut-off when disconnected. Positive valve stop maintains valve alignment and flow checking. Used on dump trucks, snow plows, mining, refuse hauling, truck-trailer connections. The 6600 series is interchangeable Parker 6600, Aeroquip FD56/5600, and ISO series A interchangeable couplers.

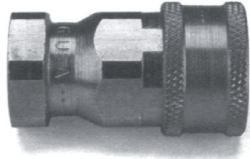

## 6600 SERIES COUPLERS

Pkg. Qty. 1 each

Part No.	Body Size	Pipe Size	Material	Pressure Rating
5649	1/4	1/4 NPTF	Steel	5000 psi
11-331	3/8	3/8 NPTF	Steel	4000 psi
5650	1/2	1/2 NPTF	Steel	4000 psi

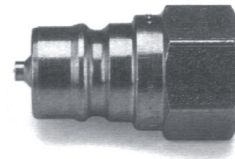

## 6600 SERIES NIPPLES

Pkg. Qty. 1 each

Part No.	Body Size	Pipe Size	Material	Pressure Rating
5646	1/4	1/4 NPTF	Steel	5000 psi
11-332	3/8	3/8 NPTF	Steel	4000 psi
5648	1/2	1/2 NPTF	Steel	4000 psi

### ACTUAL SIZE PROFILE

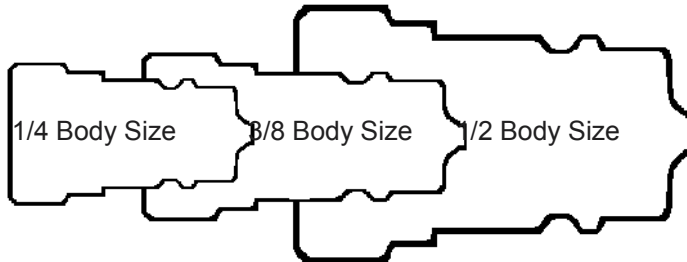

## Dust Plugs

Part No.	Series	Body Size	Material	Pkg Qty
11-333	6600	1/4	Rubber	1
11-334	6600	3/8	Rubber	1
11-335	6600	1/2	Rubber	1



## Dust Caps

Part No.	Series	Body Size	Material	Pkg Qty
11-336	6600	1/4	Rubber	1
11-337	6600	3/8	Rubber	1
11-338	6600	1/2	Rubber	1



# 3000 Series High Pressure Hydraulic Couplers

The thread-together locking system and precision ball type check valves are designed for the high pressures encountered on hydraulic pumps used for equipment such as hydraulic jacks, bearing presses, hose crimp machines. Coupling is accomplished by manually threading together the coupler and nipple halves. The 3000 series interchanges with Parker 3000, Bruning PI 370 and Enerpac C604. Material: steel body, polyurethane seals.

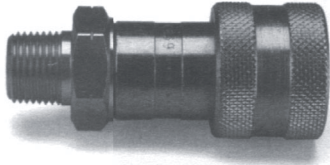

## 3000 Series Couplers

Male Pipe Thread. Pkg. Qty. 1 each

Part No.	Body Size	Pipe Size	Rated Pressure
11-341	3/8	3/8-18 MPT	10,000 psi

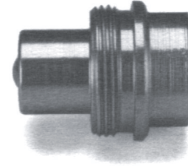

## 3000 Series Nipples

Female Pipe Thread. Pkg. Qty. 1 each

Part No.	Body Size	Pipe Size	Rated Pressure
11-342	3/8	3/8-18 FPT	10,000 psi



## Dust Plugs

Part No.	Series	Body Size	Material	Pkg Qty
11-343	3000	3/8	Steel	1



## Dust Caps

Part No.	Series	Body Size	Material	Pkg Qty
11-344	3000	3/8	Steel	1

Frank Perdue's chicken slogan, "It takes a strong man to make a tender chicken" was translated into Spanish as "I takes a special man to make a chicken affectionate."

# 6100 Series

## "Connect Under Pressure" Couplings

*("Thread-to-Connect" Fittings, "Wet-Line" Hydraulic Couplers)*

Designed for applications where a heavy duty coupling is required that can be connected under pressure with little or no spillage; reducing environmental and worker safety hazard. Low air inclusion during connection maintains system performance. Widely used on dump trailer wet-line hydraulic systems and oil field equipment. Brass construction with steel valving components and Buna N (nitrile) O-ring seal. The 6100 series interchanges with Aeroquip 5100 series.

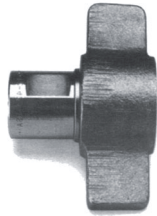

### 6100 Series Couplers

Female Pipe Thread. Pkg. Qty. 1 each

Part No.	Parker No.	Body Size	Pipe Size	Maximum Operating Pressure*
11-345	6125-12	3/4	3/4 FPT	1750 psi
11-346	6125-16	1"	1" FPT	2750 psi
11-347	6125-20	1 1/4	1 1/4 FPT	2750 psi

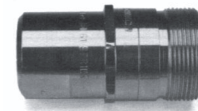

### 6100 Series Nipples

Female Pipe Thread. Pkg. Qty. 1 each

Part No.	Parker No.	Body Size	Pipe Size	Maximum Operating Pressure*
11-348	6105-12	3/4	3/4 FPT	1750 psi
11-349	6105-16	1"	1" FPT	2750 psi
11-350	6105-20	1 1/4	1 1/4 FPT	2750 psi



### 6100 Series Brass Dust Plugs

Pkg. Qty. 1 each

Part No.	Body Size
11-354	3/4
11-357	1"
11-358	1 1/4



### 6100 Series Brass Dust Caps

Pkg. Qty. 1 each

Part No.	Body Size
11-351	3/4
11-352	1"
11-353	1 1/4

### Bulkhead Mounting Flange



For rigid mounting 6100 series couplers.  
Six 3/16" bolt holes. Pkg: 1 each

Part No.	Body Size
11-359	3/4
11-360	1"
11-361	1 1/4



## Red Hot Deals!

Check out our current specials  
and new items on our website at  
<http://www.mpi-online.com>





# Modular FRL Assemblies

Installation, maintenance and repair is a snap with modular clamping system! Each assembly includes air line filter, regulator, lubricator, modular clamps and wall mount brackets. Made in U.S.A.

Basic NPT Size*	Part No.	Scfm Rating
1/4"	E72-2M-MB	36
3/8"	E73-3M-MB	70
1/2"	E74-4M-MB	140

\*Modular female pipe thread inlet and outlet supplied. Larger and smaller FRL combinations available. \*\*SCFM ratings listed at 100 PSI inlet pressure. Check ID tags on compressor for proper SCFM information.

Replacement parts, clamps, shut-off valves, filter elements and accessories available.

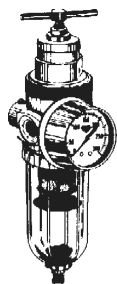
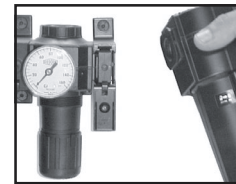
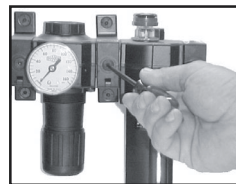
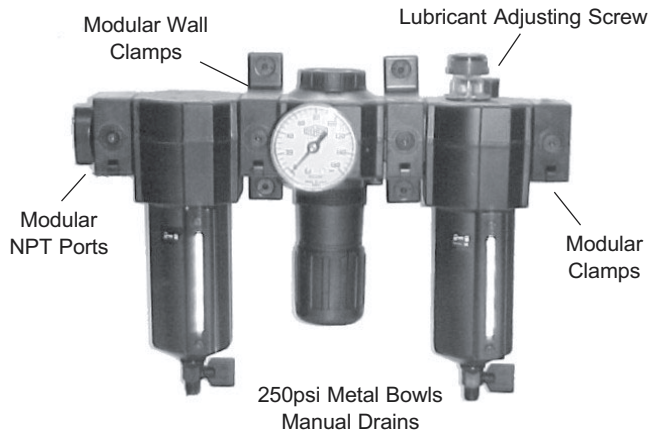

## Combination Filter-Regulator

T-handle adjustment. Includes 0-160 psi gauge. Clear, polycarbonate bowl. Manual "Push-N-Drain". Max. operating pressure: 150 psi @125°F.

Part No.	Size	Style	Flow SCFM*
12-24201	1/4 NPT	Compact	35
12-24211	3/8 NPT	Compact	45
12-24221	1/2 NPT	Standard	80
12-24231	3/4 NPT	Standard	110

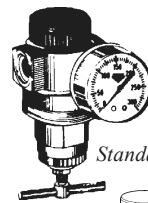

Standard

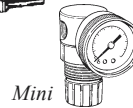

Mini

## Air Line Regulators

Standard has quick response T-handle adjustment. Mini has non-rising locking knob. Includes 0-160 psi gauge. Max. operating pressure: 250 psi. Operating temperature range: -10°F to 175°F.

Part No.	Size	Style	Flow SCFM*
12-24444	1/4 NPT	Mini	13
12-24404	1/4 NPT	Compact	50
12-24414	3/8 NPT	Compact	65
12-24424	1/2 NPT	Standard	110
12-24434	3/4 NPT	Standard	130

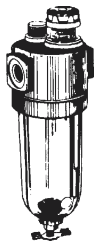

## Air Line Lubricators

Automatically lubricates air tools for longer life. Can be filled while under pressure. Clear, polycarbonate bowl. Maximum operating pressure: 150 psi @125°F. Operating temperature range: -10°F to 175°F.

Part No.	Size	Style	Flow SCFM*
12-24501	1/4 NPT	Compact	20
12-24511	3/8 NPT	Compact	35
12-24521	1/2 NPT	Standard	85
12-24531	3/4 NPT	Standard	90

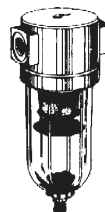

## Air Line Filters

Protects air tools from contamination. 40 micron filter element. Clear polycarbonate bowl. Manual "push-n-drain". Max. operating pressure: 150 psi @125°F. Operating temperature range: -10°F to 175°F.

Part No.	Size	Style	Flow SCFM*
12-24301	1/4 NPT	Compact	50
12-24311	3/8 NPT	Compact	75
12-24321	1/2 NPT	Standard	110
12-24331	3/4 NPT	Standard	125

Also available: Automatic Drain Kits, Replacement Bowls, and Filters. \*Standard Cubic Feet Per Minute.



# Pressure Gauges

## General Service Pressure Gauges



For general use wherever stem mounting is desirable and the pressure medium is non-corrosive to brass, phosphor bronze or beryllium copper. Air, oil, gas and water services are the most common applications.

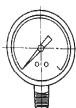

### 2" FACE 1/4" NPT LOWER MOUNT

Steel case

Part No.	Range (PSI)	Pkg Qty
70-004	0-30	1
70-006	0-60	1
70-008	0-100	1
70-010	0-160	1
70-012	0-200	1
70-014	0-300	1

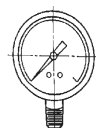

### 2-1/2" Face 1/4" NPT LOWER MOUNT

Steel case

Part No.	Range (PSI)	Pkg Qty
70-020	0-30	1
70-022	0-60	1
70-024	0-100	1
70-026	0-160	1
70-028	0-200	1
70-030	0-300	1
70-032	0-600	1



### 2" FACE 1/4" NPT BACK MOUNT

Steel case

Part No.	Range (PSI)	Pkg Qty
70-058	0-160	1

## Liquid Filled Pressure Gauges



### Long Service Life • Stainless Steel

Glycerin filled gauges dampen vibration and shock, protects components from pressure pulsations, and lubricates components increasing wear life. For use in moderate temperatures. Not for use with oxygen, chlorine, nitric acid, and hydrogen peroxide.

### 2-1/2" FACE 1/4" NPT LOWER MOUNT

Corrosion resistant stainless steel case  
Temperature range: 30°F - 150°F

Part No.	Range (PSI)	Pkg Qty
70-090	0-30	1
70-091	0-60	1
70-092	0-100	1
70-093	0-160	1
70-094	0-200	1
70-095	0-300	1
70-096	0-600	1
70-081	0-1000	1
70-082	0-2000	1
70-083	0-3000	1
70-084	0-5000	1
70-085	0-10,000	1

*NOTE - liquid filled gauges have an air bubble to allow for liquid expansion where extreme temperature changes may exist.*



# Safety Pop-Off Valve

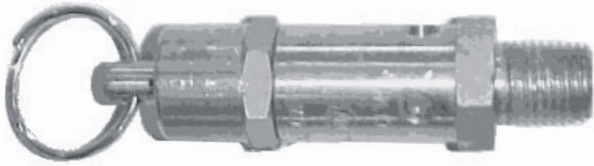

Designed to protect air tanks from over-pressure. Maximum operating temperature is 250°F. All brass construction with chrome steel ball. All 1/4" NPT male threads.

Part No.	Pre-Set Pressure	Pkg Qty
11-366	100 psi	1
11-367	125 psi	1
11-368	150 psi	1
11-369	175 psi	1
11-370	200 psi	1

# Brass In-Line Swivels

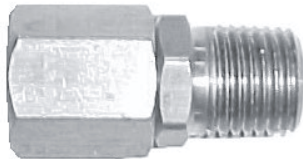

For fast and efficient service that avoids hose kinking. For use with air only. Rated to 150 psi.

Part No.	Male NPT	Female NPT	Pkg Qty
11-363	1/4	1/4	1



# 3 in 1 Air Manifold

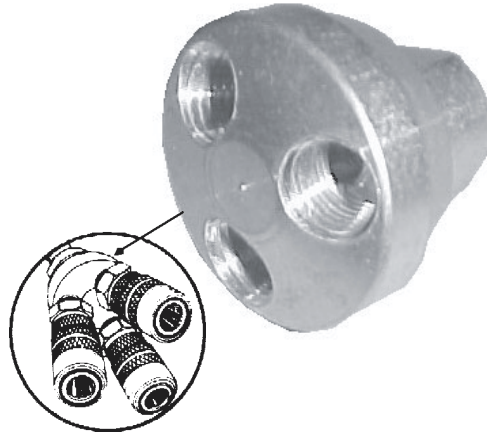

Accepts three air hoses or quick disconnect couplers. Machined aluminum construction. Supply three air operated tools from a single supply hose. Mount to pipe at workbench or overhead to permit use of air supply by more than one worker. Using different couplers types? Mount three different coupler styles on one manifold!

Part No.	Inlet/Outlet Size	Pkg
11-362	1/4 Female NPT	1



## The Doctor is in!

See page 338

# Quick Release Hose Clamps

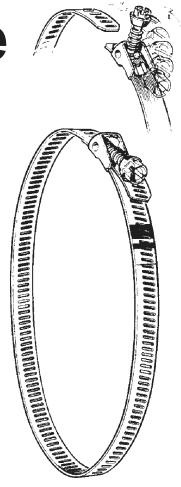
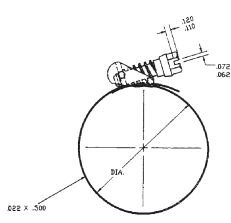

Unique swivel action screw opens for easy installations where clamp must be opened to be applied. Ideal where repeated removal of clamps are necessary. Wide diameter range makes this the perfect hose clamp for service vehicles and emergencies in the field. Housing and band are 301 stainless steel, hardened steel screw is zinc plated. Maximum suggested torque is 30 in/lbs.

1. LOOP DISENGAGED CLAMP AROUND OBJECT.
2. SLIP BAND THROUGH HOUSING.
3. SNAP SCREW DOWN AND TIGHTEN.

Part No.	SAE Size	Dia. Range	Pkg Qty
2422	152	2" to 10"	10
2421	188	2" to 12"	10

# Welding Hose



Abrasion, weather and ozone resistant grade R1 rubber hose for oxygen and acetylene service. Meets CGA and RMA requirements. Bonded twin-line. Color-coded oxygen (green) and acetylene (red) lines. Assembled with B-size 9/16-18 swivel fittings each end. Made in U.S.A.

Part No.	Size	Pkg Qty
21-299	1/4 I.D. x 50'	1 RL

# Welding Hose Fittings



## Swivel Nut Welding Connector *Oxy-Acetylene Hose Coupling*

Part No.	1 Hose I.D.	2 Thread Size	Pkg Qty
RIGHT-HAND THREAD			
13-416	3/16"	9/16-18 RH	6
13-417	1/4"	9/16-18 RH	6
13-418	5/16"	9/16-18 RH	6
13-419	3/8"	9/16-18 RH	6
LEFT-HAND THREAD			
13-420	3/16"	9/16-18 LH	6
13-421	1/4"	9/16-18 LH	6
13-422	5/16"	9/16-18 LH	6
13-423	3/8"	9/16-18 LH	6



## Welding Unions

*Use to join oxy-acetylene hoses for longer assemblies.*

Part No.	Size/Thread	Pkg Qty
13-424	9/16-18 / Right Hand	6
13-425	9/16-18 / Left Hand	6



**We stock a  
complete line of  
Welding Supplies!**

See pages 403-413



# Multi-Barb Brass Fittings

For use with low pressure air and water hose.  
Hose clamp or ferrule required.

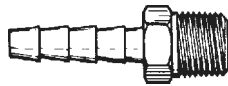

**Hose Barb**  
Tube to Male Pipe

Part No.	Hose I.D.	Pipe Size	Pkg
27-710	3/16	1/8	10
27-711	1/4	1/8	10
27-712	1/4	1/4	10
27-713	1/4	3/8	10
27-714	5/16	1/8	10
27-715	5/16	1/4	10
27-716	3/8	1/8	5
27-717	3/8	1/4	5
27-718	3/8	3/8	5
27-719	3/8	1/2	5
27-720	1/2	1/4	5
27-721	1/2	3/8	5
27-722	1/2	1/2	5
27-723	5/8	1/2	5
27-724	3/4	1/2	5
27-725	3/4	3/4	5



**Hose Mender**

Part No.	Hose I.D.	Pkg
27-726	3/16	10
27-727	1/4	10
27-728	5/16	10
27-729	3/8	5
27-730	1/2	5

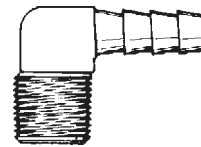

**90° Hose Barb Elbow**  
Tube to Male Pipe

Part No.	Hose I.D.	Pipe Size	Pkg
27-735	1/4	1/8	10
27-736	1/4	1/4	10
27-737	3/8	1/4	5

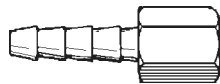

**Hose Barb**  
Tube to Female Pipe

Part No.	Hose I.D.	Pipe Size	Pkg
27-731	1/4	1/8	10
27-732	1/4	1/4	10
27-733	3/8	1/4	5
27-734	1/2	1/2	5

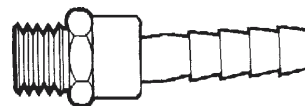

**360° Ball Swivels**  
Prevents kinks in hose. Tube to Male Pipe

Part No.	Hose I.D.	Pipe Size	Pkg
27-840	1/4	1/4	1
27-841	3/8	1/4	1

*A woman who has  
never seen her husband fishing  
doesn't know what a patient  
man she has married.*

- Ed Howe



# Reusable Air Hose Fittings

Large inside diameter gives greater volume of air, hose stays in nut when assembling. Fitting grips hose tighter than crimped fittings. Pkg. Qty. 2 each.

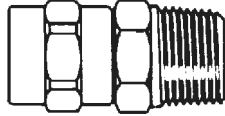

## Reusable Male Connector

Part No.	Hose O.D.	Hose I.D.	Thread Size	Fits Hoses
27-821	1/2	1/4	1/4	4730 4772
27-822	9/16	1/4	1/4	Misc.
27-823	5/8	1/4	1/4	Misc.
27-824	5/8	5/16	1/4	Misc.
27-825	5/8	3/8	1/4	4731
27-826	11/16	3/8	1/4	4773

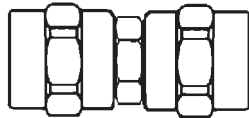

## Reusable Hose Splicer

(Hose Mender)

Part No.	Hose O.D.	Hose I.D.	Fits Hoses
27-829	1/2	1/4	4730 4772
27-830	9/16	1/4	Misc.
27-831	5/8	1/4	Misc.
27-832	5/8	5/16	Misc.
27-833	5/8	3/8	4731
27-834	11/16	3/8	4773

NOTE: Check Hose O.D. accurately before ordering.

# Universal Beaded Brass Fittings

For fuel lines and heater hoses



## Male Pipe

Part No.	Hose I.D.	Pipe Size	Pkg
27-780	3/16	1/8	10
27-781	1/4	1/8	10
27-782	1/4	1/4	10
27-783	5/16	1/8	10
27-784	5/16	1/4	10
27-785	3/8	1/8	10
27-786	3/8	1/4	10
27-787	3/8	3/8	10
27-800	1/2	3/8	5
27-801	5/8	3/8	5
27-802	5/8	1/2	5
27-803	3/4	1/2	5



## Male Pipe 90° Elbow

Part No.	Hose I.D.	Pipe Size	Pkg
27-788	1/4	1/8	10
27-789	5/16	1/8	10
27-790	5/16	1/4	10
27-791	3/8	1/8	10
27-792	3/8	1/4	10
27-804	5/8	3/8	5
27-805	5/8	1/2	5
27-806	3/4	1/2	5

BE CAREFUL OF A PERSON WHO ASKS YOU TO KEEP A SECRET  
FOR IT IS EVIDENT THEY CANNOT DO SO.



# Water Hose and Nozzles



## Contractors Water Hose

EPDM rubber tube and cover. Spiral reinforced. Heavy duty crushproof solid brass couplings with wrench grips. Working press. 150PSI. Temp. range: -20°F to 180°F

Part No.	Size	Pkg
17-144	3/4"ID x 50'	1



## Insulated Water Nozzle

Industrial strength, insulated handle. All brass valve stem and adjusting nut. Dial open valve stays adjusts to any pressure. Adjustable spray pattern. Withstands temperatures to 180°F. **Part No. 30-274**



## Economy Water Nozzle

All zinc metalized body for cold water use. All brass valve stem and adjusting nut. Hold open clip locks to any spray pattern. **Part No. 13-433**

# Garden Hose Fittings

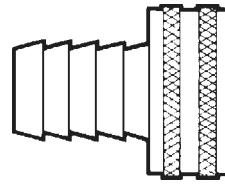

## Female Garden Hose Swivel Connector

*Hose Barb to Female Garden Hose Swivel. Brass.*

Part No.	Size	Pkg Qty
13-426	1/2ID x 3/4GHT	6
13-427	5/8ID x 3/4GHT	6
13-428	3/4ID x 3/4GHT	6

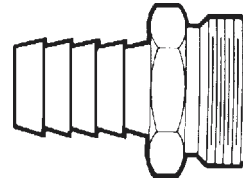

## Male Garden Hose Connector

*Hose Barb to Rigid Male Garden Hose. Brass.*

Part No.	Size	Pkg Qty
13-429	1/2ID x 3/4GHT	6
13-430	5/8ID x 3/4GHT	6
13-431	3/4ID x 3/4GHT	6



## Garden Hose Repair Fittings

*Clinch style installs easily with a hammer. Fits 5/8 ID Garden Hose. Brass. Pkg. Qty. 10 each*

Part No.	Type	Size
13-435	Female Swivel	5/8ID x 3/4GHT
13-436	Male	5/8ID x 3/4GHT
13-437	Hose Mender	5/8ID x 5/8ID

## Vinyl Garden Hose Washers

Fits standard 3/4" female garden hose fittings. Pkg: 100 each. **Part No. 13-434**



# Garden Hose Fittings (Cont'd)

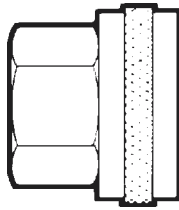

## Swivel Female Garden Hose Adapter

*Rigid Female Pipe to Female Garden Hose. Brass.*

Part No.	Size	Pkg Qty
13-438	1/2NPT x 3/4GHT	6
13-439	3/4NPT x 3/4GHT	6

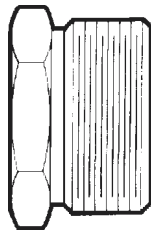

## Male Garden Hose Adapter

*Rigid Female Pipe to Male Garden Hose. Brass.*

Part No.	Size	Pkg Qty
13-440	1/2NPT x 3/4GHT	6
13-441	3/4NPT x 3/4GHT	6

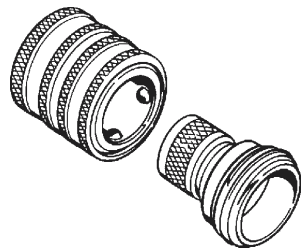

## Brass Garden Hose Quick Coupler

Constructed of corrosion resistant brass and stainless steel. Durable 3-ball locking mechanism and nitrile seats for a secure, leak-free connection. Use anywhere hoses are connected frequently. Max. operating pressure: 200 PSI.

#13-442	Complete Set
#13-442A	Coupler Only
#13-442B	Nipple Only

# Air Hose Crimper

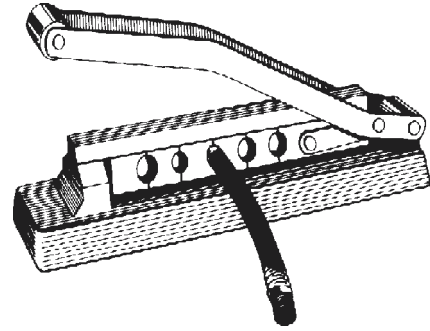

For low pressure applications. Has 5 dies for 1/4" 1-braid through 3/8" 2 braid low pressure hoses. Dies are self-contained....No separate dies to lose or misplace. Easy one-hand operation gives tremendous leverage by positive camming action at end of lever stroke. **Part No. 21-369**

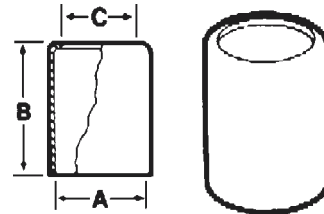

## Brass Hose Ferrules

Lightweight for low pressure air applications. Pkg. 50 ea.

Part No.	A I.D.	B O.L.	C End Hole	Thick-ness
27-807*	.450	.688	.360	.016
13-443	.478	.688	.328	.024
27-808*	.525	.500	.425	.016
27-809*	.562	1.00	.438	.024
13-444	.593	1.00	.438	.024
13-445	.625	1.00	.438	.024
27-810*	.650	.500	.550	.019
13-446	.687	1.00	.500	.024
27-811*	.718	1.00	.500	.024
27-813	.750	1.00	.625	.024
27-812*	.850	.568	.688	.019

\* Items included in hose ferrule kit below



**HOSE FERRULE MAINTENANCE KIT**  
6 SIZES IN A CLEAR STYRENE BOX.  
**PART NO. 540MK**



# Vacuum & Windshield Washer Tubing Connectors



## Polyethylene Hose Tee Connectors

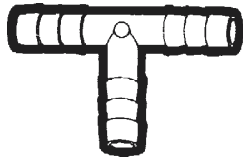

Part No.	Tubing I.D.	Pkg Qty
27-740	1/8	10
27-741	5/32	10
27-742	3/16	10
27-743	1/4	10
27-744	5/16	10
27-745	3/8	10

## Polyethylene Hose Connectors



Part No.	Tubing I.D.	Pkg Qty
27-746	1/8	10
27-747	3/16	10
27-748	1/4	10
27-749	5/16	10
27-750	3/8	10
<b>REDUCERS</b>		
27-751	1/4 x 3/16	10
27-752	3/8 x 1/4	10

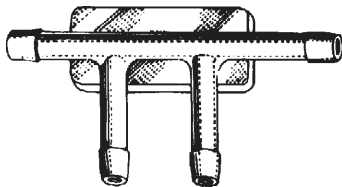

## 4-Way Nylon Connectors

Part No.	Tubing I.D.	Pkg Qty
27-773	3/16 ALL ENDS	10



## Polyethylene Universal Connector

Part No.	Tubing I.D.	Pkg Qty
27-771	1/8-1/4-3/8	10



## Vacuum Caps

Special heat resistant rubber compound

Part No.	Tube Size	Pkg Qty
27-753	1/8	25
27-754	3/16	25
27-755	1/4	25
27-756	5/16	25
27-757	3/8	25
27-758	1/2	10

## Polyethylene Universal Tee

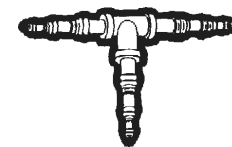

Part No.	Tubing I.D.	Pkg Qty
27-772	1/8-1/4-3/8	10





# Universal Air Couplings

*"Quarter-turn" or "Chicago" type fittings*

For air service only. Self-mating head design allows each coupling listed to mate with each other. Two lug, malleable iron. Rated to 110 PSI. Rubber Seal included. Use of Safety Clip (included) assures proper connection and prevents accidental disconnection.

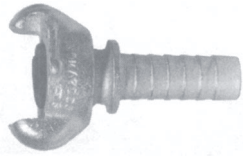

## Hose Ends

Part No.	Size	Pkg Qty
6500	1/2 Hose I.D.	5
6501	3/4 Hose I.D.	5
6502	1" Hose I.D.	5

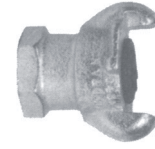

## Female Pipe Thread Ends

Part No.	Size	Pkg Qty
6503	1/2 NPT Female	5
6504	3/4 NPT Female	5
6505	1" NPT Female	5



## Double Bolt Clamps

Part No.	Size	For Hose O.D.'s		Torque*	Pkg Qty
		From:	To:		
5476	3/8	11/16	7/8	6	5
5477	1/2	1"	1-3/16	6	5
5478	3/4	1-1/8	1-5/16	12	5
5479	7/8	1-5/16	1-1/2	12	5
5480	1"	1-1/2	1-13/16	21	5

*\*Recommended torque rated in FT. LBS.*



## Male Pipe Thread Ends

Part No.	Size	Pkg Qty
6506	1/2 NPT Male	5
6507	3/4 NPT Male	5
6508	1" NPT Male	5

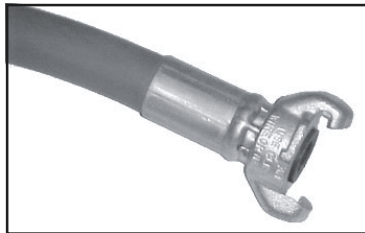

## Contractor Grade Air Hose

*Assembled with 2-lug air couplings.*

Part No.	Item	Qty
4790-2	3/4 ID x 50 ft Assembly	1 roll
4790	Bulk Hose (uncoupled)	350'



## Two-Lug Hose Ends

For 3/4" id air hose. Can be crimped or swaged-on contractors air hose above. Pkg: 1 each  
**Part No. 8300**



## Replacement Seals

Fits all 2 lug air couplings.  
Pkg: 25 each **Part No. 6510**



## Safety Clips

Fits all 2 lug air couplings.  
Pkg: 25 each **Part No. 5481**



## Safety Pins

.091" diam. for all 2 lug air couplings. Pkg: 10 each  
**Part No. 7-2120**

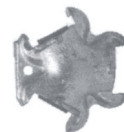

## Triple Connection

Fits all 2 lug air couplings.  
Pkg: 1 each **Part No. 6509**



# Steel Hose Barbs

(Combination Nipples , King Nipples)



## Hose Nipples

Machined steel, zinc plated. Male N.P.T.

Part No.	Hose I.D.	Pipe Thread	Pkg Qty
6511	1/4	1/8 NPT	10
6512	1/4	1/4 NPT	10
6513	3/8	1/4 NPT	10
6514	3/8	3/8 NPT	10
6515	1/2	3/8 NPT	5
6516	1/2	1/2 NPT	5
6517	3/4	1/2 NPT	5
6518	3/4	3/4 NPT	5



## Hose Nipples

Forged steel. Zinc plated. Male NPT

Part No.	Hose I.D.	Pipe Thread	Pkg Qty
6519	1"	1"	2
6520	1-1/4	1-1/4	2
6521	1-1/2	1-1/2	2
6522	2"	2"	2
6523	2-1/2	2-1/2	2
6524	3"	3"	2



## Hose Menders

Forged steel. Zinc plated

Part No.	Hose I.D.	Pkg Qty
6525	1/4	10
6526	3/8	10
6527	1/2	5
6528	3/4	5
6529	1"	2
6530	1-1/4	2
6531	1-1/2	2
6532	2"	2
6533	2-1/2	2
6534	3"	2

# Push-On Hose



300 psi max. working pressure. Also available in bulk.

Part No.	Hose I.D.	Hose O.D.	Working PSI	Burst PSI	Pkg Qty
4700	1/4	.50	300	1200	50'
4701	3/8	.62	300	1200	50'
4702	1/2	.75	300	1200	50'
4703	5/8	.91	300	1200	50'
4704	3/4	1.03	300	1200	50'

# Push-On Couplings

Reusable brass couplings for use with "push-on" hose. No clamps required.

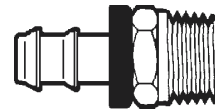

## Rigid Male NPTF

Part No.	Hose I.D.	Pipe Thread	Pkg Qty
4900•	1/4	1/8-27	5
4901•	1/4	1/4-18	5
13-447	3/8	1/8-27	5
4902•	3/8	1/4-18	5
4903•	3/8	3/8-18	5
4904•	1/2	3/8-18	5
4905•	1/2	1/2-14	5
4906•	5/8	1/2-14	5
4907•	3/4	3/4-14	5

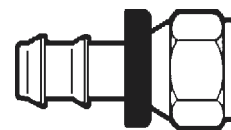

## Female Swivel

Part No.	Hose I.D.	Tube O.D.	Thread Size	Pkg Qty
DUAL SEAT - 37° & 45° FLARE				
4908•	1/4	1/4	7/16-20	5
4909	1/4	5/16	1/2-20	5
4910	3/8	1/2	3/4-16	5
4911•	1/2	1/2	3/4-16	5
4912	1/2	5/8	7/8-14	5
4913•	5/8	5/8	7/8-14	5
45° FLARE				
4914•	3/8	3/8	5/8-18	5
37° FLARE				
4916•	3/8	3/8	9/16-18	5

Part Numbers with bullet(•) included in assortment #16-0420

# Push-On Couplings

(Cont'd)

Reusable brass couplings for use with "push-on" hose. No clamps required.

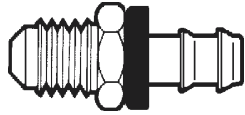

## SAE 45° Male Flare (Rigid)

Part No.	Hose I.D.	Tube O.D.	Thread Size	Pkg Qty
4918•	1/4	1/4	7/16-20	5
4920	1/4	5/16	1/2-20	5
4922	3/8	3/8	5/8-18	5
4923	1/2	1/2	3/4-16	5

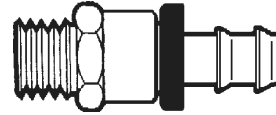

## 360° Ball Swivel - Male NPTF

Part No.	Hose I.D.	Male Pipe	Pkg Qty
4942	1/4"	1/4"	1
4943	3/8"	1/4"	1

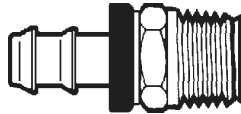

## Swivel Male Inverted Flare

Part No.	Hose I.D.	Tube O.D.	Thread Size	Pkg Qty
4924	1/4	3/16	3/8-24	5
4925•	1/4	1/4	7/16-24	5
4926•	1/4	5/16	1/2-20	5
4927•	3/8	3/8	5/8-18	5
4928	1/2	1/2	3/4-18	5



**BRASS PUSH-ON COUPLING ASSORTMENT**  
20 SIZES, 1/4" - 5/8" ID COUPLINGS IN A  
LARGE STEEL DRAWER. **PART NO. 16-0420**



## Hose Mender (Union)

Part No.	Hose I.D.	Pkg Qty
4938•	1/4	10
4939•	3/8	10
4940•	1/2	5
4941	5/8	5

## Kink-resistant Polyurethane Self-Store Hose

See page 204



**ORDER BY THE  
PACKAGE AND SAVE!**



Part Numbers with bullet(•) included in assortment #16-0420





# SAE 100R5 Medium Pressure Hose

("Aeroquip" Style)

**Pkg Qty: 25 ft**

Part No.	Hose I.D.	Hose O.D.	Working PSI	Burst PSI
4710	3/16 <sup>(-4)</sup>	.52	3,000	12,000
4711	1/4 <sup>(-5)</sup>	.58	3,000	12,000
4712	5/16 <sup>(-6)</sup>	.67	2,250	9,000
4713	13/32 <sup>(-8)</sup>	.77	2,000	8,000
4714	1/2 <sup>(-10)</sup>	.92	1,750	7,000
4715	5/8 <sup>(-12)</sup>	1.08	1,500	6,000

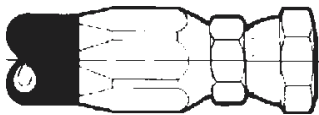

## Female SAE 45° Swivel Reusable Coupling

Part No.	Hose I.D.	Tube O.D.	Thread Size	Pkg Qty
4985	3/16 <sup>(-4)</sup>	1/4 <sup>(-4)</sup>	7/16-20	5
4986	1/4 <sup>(-5)</sup>	5/16 <sup>(-5)</sup>	1/2-20	5
4987	5/16 <sup>(-6)</sup>	3/8 <sup>(-6)</sup>	5/8-18	5
4988	13/32 <sup>(-8)</sup>	1/2 <sup>(-8)</sup>	3/4-16	5
4989	1/2 <sup>(-10)</sup>	5/8 <sup>(-10)</sup>	7/8-14	5
4990	5/8 <sup>(-12)</sup>	3/4 <sup>(-12)</sup>	1-1/16-14	3

*Weeping may endure  
for a night, but joy  
cometh in the morning.*

-Psalms 30:5

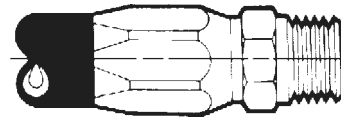

## Rigid Male NPTF Reusable Couplings

Part No.	Hose I.D.	Pipe Thread	Pkg Qty
4960	3/16 <sup>(-4)</sup>	1/8-27 <sup>(-2)</sup>	5
4961	3/16 <sup>(-4)</sup>	1/4-18 <sup>(-4)</sup>	5
4962	1/4 <sup>(-5)</sup>	1/4-18 <sup>(-4)</sup>	5
4963	5/16 <sup>(-6)</sup>	1/4-18 <sup>(-4)</sup>	5
4964	5/16 <sup>(-6)</sup>	3/8-18 <sup>(-6)</sup>	5
4965	13/32 <sup>(-8)</sup>	3/8-18 <sup>(-6)</sup>	5
4966	13/32 <sup>(-8)</sup>	1/2-14 <sup>(-8)</sup>	5
4967	1/2 <sup>(-10)</sup>	1/2-14 <sup>(-8)</sup>	5
4970	5/8 <sup>(-12)</sup>	3/4-14 <sup>(-12)</sup>	3

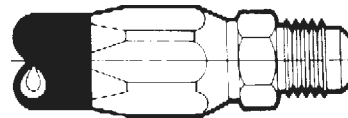

## Rigid Male 37° Flare Reusable Couplings

Part No.	Hose I.D.	Tube O.D.	Thread Size	Pkg Qty
4991	3/16 <sup>(-4)</sup>	1/4 <sup>(-4)</sup>	7/16-20	5
4992	1/4 <sup>(-5)</sup>	5/16 <sup>(-5)</sup>	1/2-20	5
4993	5/16 <sup>(-6)</sup>	3/8 <sup>(-6)</sup>	9/16-18	3
4994	13/32 <sup>(-8)</sup>	1/2 <sup>(-8)</sup>	3/4-16	3
4995	1/2 <sup>(-10)</sup>	5/8 <sup>(-10)</sup>	7/8-14	2
4997	5/8 <sup>(-12)</sup>	3/4 <sup>(-12)</sup>	1-1/16-12	2

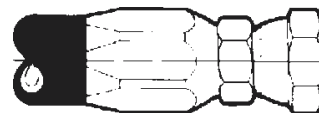

## Female JIC 37° Swivel Reusable Couplings

Part No.	Hose I.D.	Tube O.D.	Thread Size	Pkg Qty
4975	3/16 <sup>(-4)</sup>	1/4 <sup>(-4)</sup>	7/16-20	5
4976	1/4 <sup>(-5)</sup>	5/16 <sup>(-5)</sup>	1/2-20	5
4977	5/16 <sup>(-6)</sup>	3/8 <sup>(-6)</sup>	9/16-18	5
4978	13/32 <sup>(-8)</sup>	1/2 <sup>(-8)</sup>	3/4-16	5
4979	1/2 <sup>(-10)</sup>	5/8 <sup>(-10)</sup>	7/8-14	5
4981	5/8 <sup>(-12)</sup>	3/4 <sup>(-12)</sup>	1-1/16-12	3

All fittings on this page for use with SAE 100R5 Medium Pressure Hose.

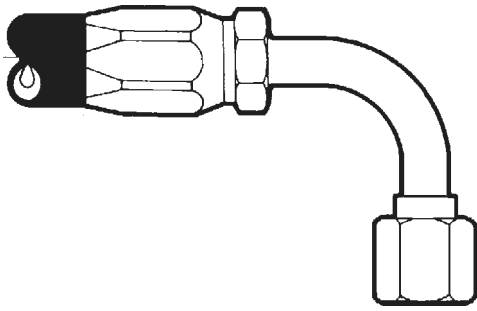

### 90° Bent Tube Female Swivel Reusable Couplings

*37° Flare*

Part No.	Hose I.D.	Tube O.D.	Thread Size	Pkg Qty
5009	3/16	1/4	7/16-20	5
5010	1/4	5/16	1/2-20	5
5011	5/16	3/8	5/8-18*	5
5012	5/16	3/8	9/16-18	5
5013	13/32	1/2	3/4-16	3
5014	1/2	5/8	7/8-14	3
5015	5/8	3/4	1-1/16-14*	2
5016	5/8	3/4	1-1/16-12	2

*\*SAE 45° Flare*

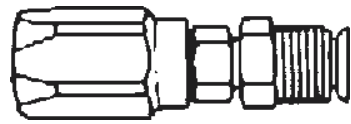

### SAE Inverted Male Swivel Reusable Couplings

Part No.	Hose I.D.	Tube O.D.	Thread Size	Pkg Qty
5028	3/16	1/4	7/16-24	4
5029	1/4	5/16	1/2-20	2
5030	5/16	3/8	5/8-18	2
5031	13/32	1/2	3/4-18	2

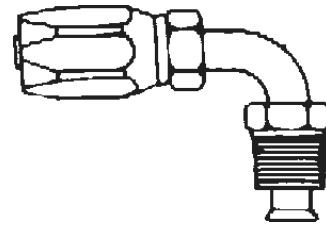

### SAE Inverted Male Swivel 90° Elbow Reusable Couplings

Part No.	Hose I.D.	Tube O.D.	Thread Size	Pkg Qty
5034	1/4	5/16	1/2-20	2
5035	5/16	3/8	5/8-18	2
5037	13/32	3/8	5/8-18	2

## NEED AN ASSORTMENT?

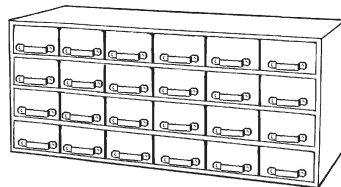

Let MPI assemble the assortment that fits your needs!

See assortments on page 463



**Red Hot Deals!**

Check out our current specials and new items on our website at <http://www.mpi-online.com>

*All fittings on this page for use with SAE 100R5 Medium Pressure Hose.*



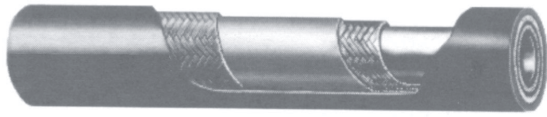

## SAE 100R2 AT High Pressure Hose

Part No.	Hose I.D.	Hose O.D.	Working PSI	Burst PSI	Pkg Qty
4741	1/4 <sup>(-4)</sup>	.59	5,000	20,000	50'
4742	3/8 <sup>(-6)</sup>	.75	4,000	16,000	50'
4743	1/2 <sup>(-8)</sup>	.87	3,500	14,000	50'
4749	5/8 <sup>(-10)</sup>	.95	2,750	11,000	25'
4744	3/4 <sup>(-12)</sup>	1.17	2,250	9,000	25'
4745	1" <sup>(-16)</sup>	1.50	2,000	8,000	25'



**DAYCO  
EASTMAN**

## HYDRAULIC HOSES MADE HERE!

Custom hydraulic, air and  
oil lines crimped to your  
specifications at MPI!

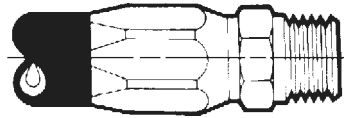

## Rigid Male NPTF Reusable Couplings

Part No.	Hose I.D.	Pipe Thread	Pkg Qty
5102	1/4 <sup>(-4)</sup>	1/8-27 <sup>(-2)</sup>	5
5103	1/4 <sup>(-4)</sup>	1/4-18 <sup>(-4)</sup>	5
5105	3/8 <sup>(-6)</sup>	1/4-18 <sup>(-4)</sup>	5
5106	3/8 <sup>(-6)</sup>	3/8-18 <sup>(-6)</sup>	5
5108	1/2 <sup>(-8)</sup>	3/8-18 <sup>(-6)</sup>	5
5109	1/2 <sup>(-8)</sup>	1/2-14 <sup>(-8)</sup>	5
5110	1/2 <sup>(-8)</sup>	3/4-14 <sup>(-12)</sup>	3
5111	3/4 <sup>(-12)</sup>	3/4-14 <sup>(-12)</sup>	3
5112	1" <sup>(-16)</sup>	3/4-14 <sup>(-12)</sup>	2
5113	1" <sup>(-16)</sup>	1-11½ <sup>(-16)</sup>	2

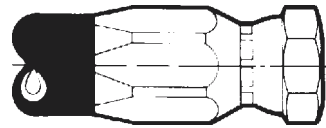

## Female Swivel 37° Flare Reusable Couplings

Part No.	Hose I.D.	Tube O.D.	Thread Size	Pkg Qty
5118	1/4 <sup>(-4)</sup>	1/4 <sup>(-4)</sup>	7/16-20	5
5119	1/4 <sup>(-4)</sup>	5/16 <sup>(-5)</sup>	1/2-20	5
5120	1/4 <sup>(-4)</sup>	3/8 <sup>(-6)</sup>	9/16-18	5
5121	3/8 <sup>(-6)</sup>	3/8 <sup>(-6)</sup>	9/16-18	5
5122	3/8 <sup>(-6)</sup>	1/2 <sup>(-8)</sup>	3/4-16	5
5123	1/2 <sup>(-8)</sup>	1/2 <sup>(-8)</sup>	3/4-16	5
5124	1/2 <sup>(-8)</sup>	5/8 <sup>(-10)</sup>	7/8-14	5
5125	1/2 <sup>(-8)</sup>	3/4 <sup>(-12)</sup>	1-1/16-12	5
5126	3/4 <sup>(-12)</sup>	5/8 <sup>(-10)</sup>	7/8-14	3
5127	3/4 <sup>(-12)</sup>	3/4 <sup>(-12)</sup>	1-1/16-12	3
5128	1"	1"	1-5/16-12	2

The human tongue,  
though light in weight,  
is difficult to hold.

*All fittings on this page for use with SAE 100R2 Type AT Thin Cover High Pressure Hose.*



## SAE 100R1 AT Medium Pressure Hose

Part No.	Hose I.D.	Hose O.D.	Working PSI	Burst PSI	Pkg Qty
4705	1/4 <sup>(-4)</sup>	.53	2,750	11,000	50'
4706	3/8 <sup>(-6)</sup>	.69	2,250	9,000	50'
4707	1/2 <sup>(-8)</sup>	.81	2,000	8,000	50'
4708	3/4 <sup>(-12)</sup>	1.09	1,250	5,000	25'
4709	1" <sup>(-16)</sup>	1.41	1,000	4,000	25'

*Reusable fittings for this hose are available on request.*

## SPECIAL FITTINGS? YOU BETCHA!



Weld fittings, tank fittings, strainers, fire hose fittings, nozzles, cam & groove couplings, shank fittings, swivel joints, boss fittings & more!

**Call MPI for your  
free Dixon catalog today!**

## Dayco HY Series Crimp Fittings

Swage-Crimp field attachable hose ends. For use with these hose styles;

SAE 100R1 Type AT  
SAE 100R2 Type AT  
SAE 30R1  
SAE 30R2, Type 1, 2, or 3  
SAE 30R4, Type 2

**All Pkg. Qty. 1 each**

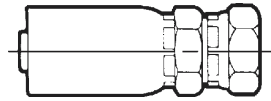

### JIC 37° Flare Female Swivel Hose End

Part No.	Dayco No.	Hose I.D.	Thread Size
6535•	HY04-04FJ	1/4 <sup>(-4)</sup>	7/16-20 <sup>(-4)</sup>
6536•	HY04-05FJ	1/4 <sup>(-4)</sup>	1/2-20 <sup>(-5)</sup>
6537	HY04-06FJ	1/4 <sup>(-4)</sup>	9/16-18 <sup>(-6)</sup>
6546	HY06-06FJ	3/8 <sup>(-6)</sup>	9/16-18 <sup>(-6)</sup>
6547•	HY06-08FJ	3/8 <sup>(-6)</sup>	3/4-16 <sup>(-8)</sup>
6563•	HY08-08FJ	1/2 <sup>(-8)</sup>	3/4-16 <sup>(-8)</sup>
6564•	HY08-10FJ	1/2 <sup>(-8)</sup>	7/8-14 <sup>(-10)</sup>
6565	HY08-12FJ	1/2 <sup>(-8)</sup>	1-1/16-12 <sup>(-12)</sup>
6579	HY10-12FJ	5/8 <sup>(-10)</sup>	1-1/16-12 <sup>(-12)</sup>
6582•	HY12-10FJ	3/4 <sup>(-12)</sup>	7/8-14 <sup>(-10)</sup>
6583	HY12-12FJ	3/4 <sup>(-12)</sup>	1-1/16-12 <sup>(-12)</sup>
6584	HY12-14FJ	3/4 <sup>(-12)</sup>	1-3/16-12 <sup>(14)</sup>
6585	HY12-16FJ	3/4 <sup>(-12)</sup>	1-5/16-12 <sup>(-16)</sup>
6592	HY16-16FJ	1" <sup>(-16)</sup>	1-5/16-12 <sup>(-16)</sup>

• Swivel nuts will connect to either 37° (JIC) or 45° (SAE) flared male fittings

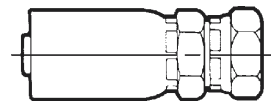

### SAE 45° Flare Female Swivel Hose End

Part No.	Dayco No.	Hose I.D.	Thread Size
6544	HY06-06FA	3/8 <sup>(-6)</sup>	5/8-18 <sup>(-6)</sup>
6581	HY12-12FA	3/4 <sup>(-12)</sup>	1-1/16-14 <sup>(-12)</sup>



# Dayco HY Series Crimp Fittings

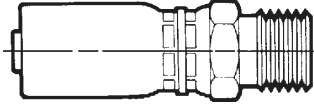

## Male Swivel NPTF Hose End

*Hose End swivels for the ease of installation and allows for very minor movement under pressure. NOT FOR EXTENSIVE SWIVELING.*

Part No.	Dayco No.	Hose I.D.	Pipe Size
6539	HY04-04SP	1/4 <sup>(-4)</sup>	1/4-18 <sup>(-4)</sup>
6549	HY06-04SP	3/8 <sup>(-6)</sup>	1/4-18 <sup>(-4)</sup>
6550	HY06-06SP	3/8 <sup>(-6)</sup>	3/8-18 <sup>(-6)</sup>
6568	HY08-08SP	1/2 <sup>(-8)</sup>	1/2-14 <sup>(-8)</sup>
6587	HY12-12SP	3/4 <sup>(-12)</sup>	3/4-14 <sup>(-12)</sup>
6593	HY16-16SP	1" <sup>(-16)</sup>	1-11½ <sup>(-16)</sup>

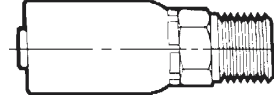

## Rigid Male NPTF Hose End

*Hose End does not swivel*

Part No.	Dayco No.	Hose I.D.	Pipe Size
6540	HY04-02MP	1/4 <sup>(-4)</sup>	1/8-27 <sup>(-2)</sup>
6541	HY04-04MP	1/4 <sup>(-4)</sup>	1/4-18 <sup>(-4)</sup>
6552	HY06-04MP	3/8 <sup>(-6)</sup>	1/4-18 <sup>(-4)</sup>
6553	HY06-06MP	3/8 <sup>(-6)</sup>	3/8-18 <sup>(-6)</sup>
6595	HY06-08MP	3/8 <sup>(-6)</sup>	1/2 <sup>(-8)</sup>
6571	HY08-06MP	1/2 <sup>(-8)</sup>	3/8-18 <sup>(-6)</sup>
6572	HY08-08MP	1/2 <sup>(-8)</sup>	1/2-14 <sup>(-8)</sup>
6573	HY08-12MP	1/2 <sup>(-8)</sup>	3/4-14 <sup>(-12)</sup>
6588	HY12-08MP	3/4 <sup>(-12)</sup>	1/2-14 <sup>(-8)</sup>
6589	HY12-12MP	3/4 <sup>(-12)</sup>	3/4-14 <sup>(-12)</sup>
6594	HY16-16MP	1" <sup>(-16)</sup>	1-11½ <sup>(-16)</sup>

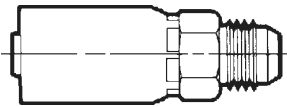

## Rigid Male JIC 37° Flare Hose End

Part No.	Dayco No.	Hose I.D.	Thread Size
6551	HY06-06MJ	3/8 <sup>(-6)</sup>	9/16-18 <sup>(-6)</sup>
6569	HY08-08MJ	1/2 <sup>(-8)</sup>	3/4-16 <sup>(-8)</sup>
6570	HY08-10MJ	1/2 <sup>(-8)</sup>	7/8-14 <sup>(-10)</sup>
6580	HY10-10MJ	5/8 <sup>(-10)</sup>	7/8-14 <sup>(-10)</sup>

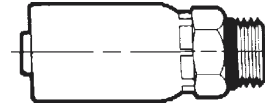

## Rigid Male O-Ring Boss Hose End

Part No.	Dayco No.	Hose I.D.	Thread Size
6554	HY06-06RA	3/8 <sup>(-6)</sup>	9/16-18 <sup>(-6)</sup>
6574	HY08-08RA	1/2 <sup>(-8)</sup>	3/4-16 <sup>(-8)</sup>
6575	HY08-10RA	1/2 <sup>(-8)</sup>	7/8-14 <sup>(-10)</sup>

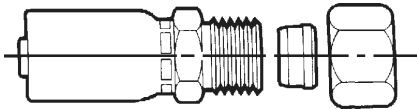

## Flareless Compression Hose End

*Repair straight or bent tubing on hose assemblies or power steering lines*

Part No.	Dayco No.	Hose I.D.	Tubing Size
6538	HY04-04MV	1/4 <sup>(-4)</sup>	1/4 <sup>(-4)</sup>
8301	HY04-06MV	1/4 <sup>(-4)</sup>	3/8 <sup>(-6)</sup>
8302	HY06-05MV	3/8 <sup>(-6)</sup>	5/16 <sup>(-5)</sup>
6548	HY06-06MV	3/8 <sup>(-6)</sup>	3/8 <sup>(-6)</sup>
8303	HY06-08MV	3/8 <sup>(-6)</sup>	1/2 <sup>(-8)</sup>
6566	HY08-08MV	1/2 <sup>(-8)</sup>	1/2 <sup>(-8)</sup>
6567	HY08-10MV	1/2 <sup>(-8)</sup>	5/8 <sup>(-10)</sup>
6586	HY12-12MV	3/4 <sup>(-12)</sup>	3/4 <sup>(-12)</sup>

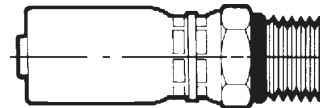

## Male Swivel O-Ring Boss Hose End

*Swivel fitting allows for very minor movement under pressure. NOT FOR EXTENSIVE SWIVELING.*

Part No.	Dayco No.	Hose I.D.	Thread Size
6576	HY08-08RC	1/2 <sup>(-8)</sup>	3/4-16 <sup>(-8)</sup>



# Dayco HY Series Crimp Fittings

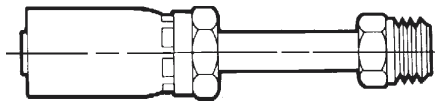

**Straight Tube Male Swivel 45°  
Inverted Flare Hose End**

Part No.	Dayco No.	Hose I.D.	Thread Size
6542	HY04-04MF	1/4 <sup>(-4)</sup>	7/16-24 <sup>(-4)</sup>
6557	HY06-06MF	3/8 <sup>(-6)</sup>	5/8-18 <sup>(-6)</sup>

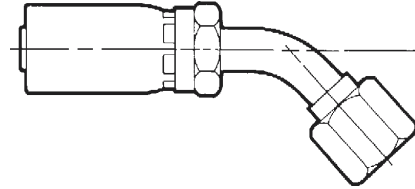

**45° Bent Tube Female Swivel 37°  
Flare Hose End**

Part No.	Dayco No.	Hose I.D.	Thread Size
6543	HY04-04FJ45T	1/4 <sup>(-4)</sup>	7/16-20 <sup>(-4)</sup>
6558	HY06-06FJ45T	3/8 <sup>(-6)</sup>	9/16-18 <sup>(-6)</sup>
6560	HY06-08FJ45T	3/8 <sup>(-6)</sup>	3/4-16 <sup>(-8)</sup>
6577	HY08-08FJ45T	1/2 <sup>(-8)</sup>	3/4-16 <sup>(-8)</sup>
6590	HY12-12FJ45T	3/4 <sup>(-12)</sup>	1-1/16-12 <sup>(-12)</sup>

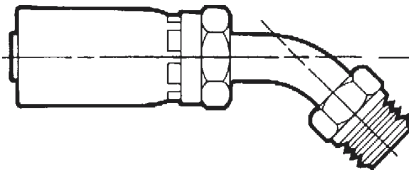

**45° Bent Tube Male Swivel 45°  
Inverted Flare Hose End**

Part No.	Dayco No.	Hose I.D.	Thread Size
6555	HY06-MF45T	3/8 <sup>(-6)</sup>	5/8-18 <sup>(-6)</sup>

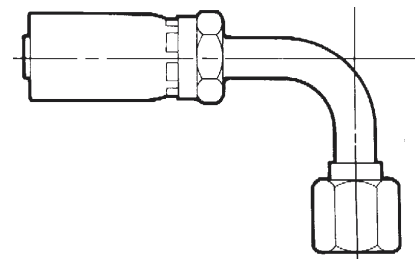

**90° Bent Tube Female Swivel 37°  
Flare Hose End**

Part No.	Dayco No.	Hose I.D.	Thread Size
6559	6RJ9-6SB	3/8 <sup>(-6)</sup>	9/16-18 <sup>(-6)</sup>
6561	8RJ9-6SB	3/8 <sup>(-6)</sup>	3/4-16 <sup>(-8)</sup>
6578	8RJ9-8SB	1/2 <sup>(-8)</sup>	3/4-16 <sup>(-8)</sup>
6591	12RJ9-12SB	3/4 <sup>(-12)</sup>	1-1/16-12 <sup>(-12)</sup>

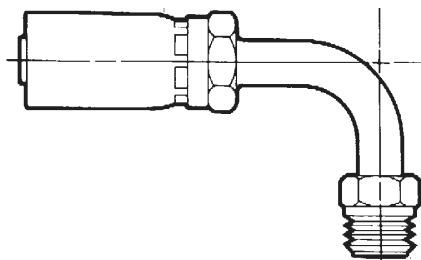

**90° Bent Tube Male Swivel 45°  
Inverted Flare Hose End**

Part No.	Dayco No.	Hose I.D.	Thread Size
6556	HY06-06MF90T	3/8 <sup>(-6)</sup>	5/8-18 <sup>(-6)</sup>



**Red Hot Deals!**

Check out our current specials  
and new items on our website at  
<http://www.mpi-online.com>

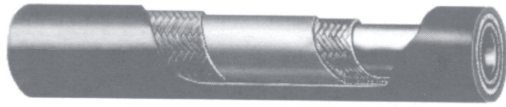

## Parker 301 Series High Pressure Hose

**SAE100R2 Type AT  
2-Wire Braid  
No-Skive Thin Cover**

Part No.	Hose I.D.	Hose O.D.	Working PSI	Burst PSI	Pkg Qty
8241	1/4 <sup>(-4)</sup>	.59	5,000	20,000	50FT
8242	3/8 <sup>(-6)</sup>	.75	4,000	16,000	50FT
8243	1/2 <sup>(-8)</sup>	.87	3,500	14,000	50FT
8244	3/4 <sup>(-12)</sup>	1.17	2,250	9,000	50FT
8245	1" <sup>(-16)</sup>	1.50	2,000	8,000	50FT
8246	1-1/4" <sup>(-20)</sup>	1.89	1,625	4,500	25FT

*\*For air & gas applications above 250 psi cover should be pin pricked.*

*Order unit is per foot*

Ask MPI about the



**You can make hydraulic hose assemblies anywhere, anytime!**

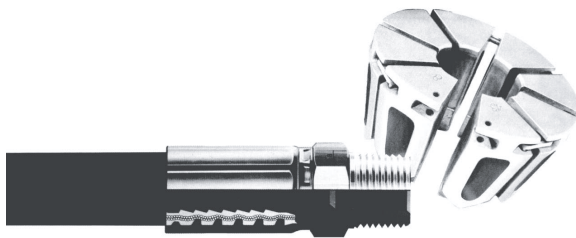

*"Put the Bite on the Braid."*

## Parker 43 Series Crimp Fittings

Swage-Crimp field attachable hose ends.  
For use with these hose styles;  
SAE 100R1 Type AT, SAE 100R2 Type AT, SAE 100R3,  
SAE 100R4, SAE 100R9 Type AT  
*All Pkg. Qty. 1 each*

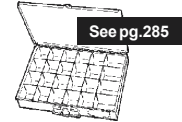
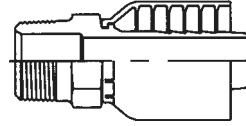

### Male NPTF Pipe - Rigid Hose Ends

Part No.	Parker No.	Pipe Size	Hose Size	Pkg Qty
8216	10143-2-4	1/8-27 <sup>(-2)</sup>	1/4 <sup>(-4)</sup>	5
8200	10143-4-4	1/4-18 <sup>(-4)</sup>	1/4 <sup>(-4)</sup>	5
8217	10143-4-6	1/4-18 <sup>(-4)</sup>	3/8 <sup>(-6)</sup>	5
8201	10143-6-6	3/8-18 <sup>(-6)</sup>	3/8 <sup>(-6)</sup>	5
8218	10143-6-8	3/8-18 <sup>(-6)</sup>	1/2 <sup>(-8)</sup>	5
8202	10143-8-8	1/2-14 <sup>(-8)</sup>	1/2 <sup>(-8)</sup>	5
8219	10143-12-8	3/4-14 <sup>(-12)</sup>	1/2 <sup>(-8)</sup>	5
8220	10143-6-10	3/8-18 <sup>(-6)</sup>	5/8 <sup>(-10)</sup>	3
8221	10143-12-10	3/4-14 <sup>(-12)</sup>	5/8 <sup>(-10)</sup>	3
8203	10143-12-12	3/4-14 <sup>(-12)</sup>	3/4 <sup>(-12)</sup>	3
8222	10143-12-16	3/4-14 <sup>(-12)</sup>	1" <sup>(-16)</sup>	2
8204	10143-16-16	1-11 1/2 <sup>(-16)</sup>	1" <sup>(-16)</sup>	2
8214	10143-20-20	1-1/4-11 1/2 <sup>(-20)</sup>	1-1/4 <sup>(-20)</sup>	2

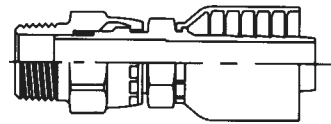

### Male NPTF Pipe Swivel\* Hose Ends

*\*swivel fitting allows minor movement under pressure but is not for extensive swiveling.*

Part No.	Parker No.	Pipe Size	Hose Size	Pkg Qty
8223	11343-4-4	1/4-18 <sup>(-4)</sup>	1/4 <sup>(-4)</sup>	3
8224	11343-4-6	1/4-18 <sup>(-4)</sup>	3/8 <sup>(-6)</sup>	3
8225	11343-6-6	3/8-18 <sup>(-6)</sup>	3/8 <sup>(-6)</sup>	3
8226	11343-8-8	1/2-14 <sup>(-8)</sup>	1/2 <sup>(-8)</sup>	3
8227	11343-12-12	3/4-14 <sup>(-12)</sup>	3/4 <sup>(-12)</sup>	2
8228	11343-16-16	1-11 1/2 <sup>(-16)</sup>	1" <sup>(-16)</sup>	2

# Parker 43 Series Crimp Fittings

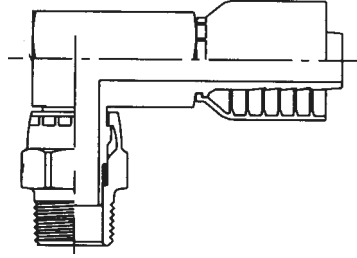

## Male NPTF Pipe 90° Elbow - Swivel Hose End

*Swivel fitting allows minor movement under pressure but is not for extensive swiveling.*

Part No.	Parker No.	Pipe Size	Hose Size	Pkg Qty
8229	11L43-4-4	1/4-18 <sup>(-4)</sup>	1/4 <sup>(-4)</sup>	3
8230	11L43-6-6	3/8-18 <sup>(-6)</sup>	3/8 <sup>(-6)</sup>	3
8231	11L43-8-8	1/2-14 <sup>(-8)</sup>	1/2 <sup>(-8)</sup>	3

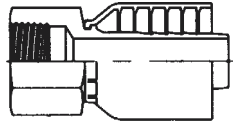

## Female NPTF Pipe Rigid Hose End

Part No.	Parker No.	Pipe Size	Hose Size	Pkg Qty
8232	10243-4-4	1/4-18 <sup>(-4)</sup>	1/4 <sup>(-4)</sup>	5
8233	10243-6-6	3/8-18 <sup>(-6)</sup>	3/8 <sup>(-6)</sup>	5
8234	10243-8-8	1/2-14 <sup>(-8)</sup>	1/2 <sup>(-8)</sup>	5
8235	10243-12-12	3/4-14 <sup>(-12)</sup>	3/4 <sup>(-12)</sup>	3

Have you ever noticed anybody going slower than you is an idiot, and anyone going faster than you is a maniac?

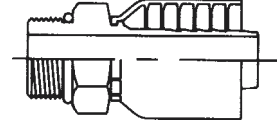

## Straight SAE Thread O-Ring Rigid Hose End

Part No.	Parker No.	Thread Size	Hose Size	Pkg Qty
8236	10543-6-4	9/16-18 <sup>(-6)</sup>	1/4 <sup>(-4)</sup>	5
8210	10543-6-6	9/16-18 <sup>(-6)</sup>	3/8 <sup>(-6)</sup>	5
8237	10543-8-6	3/4-16 <sup>(-8)</sup>	3/8 <sup>(-6)</sup>	5
8211	10543-8-8	3/4-16 <sup>(-12)</sup>	1/2 <sup>(-8)</sup>	5
8212	10543-10-8	7/8-14 <sup>(-10)</sup>	1/2 <sup>(-8)</sup>	5

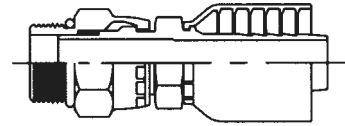

## Straight SAE Thread O-Ring Swivel\* Hose End

Part No.	Parker No.	Thread Size	Hose Size	Pkg Qty
8238	10G43-6-6	9/16-18 <sup>(-6)</sup>	3/8 <sup>(-6)</sup>	3
8239	10G43-8-6	3/4-16 <sup>(-8)</sup>	3/8 <sup>(-6)</sup>	3
8240	10G43-8-8	3/4-16 <sup>(-8)</sup>	1/2 <sup>(-8)</sup>	3

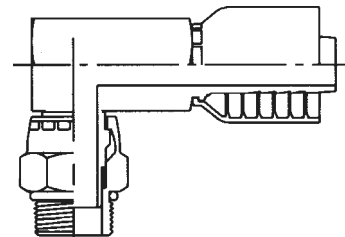

## Straight SAE Thread O-Ring 90° Elbow Swivel\* Hose End

Part No.	Parker No.	Thread Size	Hose Size	Pkg Qty
8286	10L43-8-6	3/4-16 <sup>(-8)</sup>	3/8 <sup>(-6)</sup>	3
8287	10L43-8-8	3/4-16 <sup>(-8)</sup>	1/2 <sup>(-8)</sup>	3

*\*Swivel fitting allows minor movement under pressure but is not for extensive swiveling.*

# Parker 43 Series Crimp Fittings

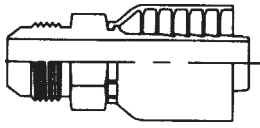

## Male JIC 37° Hose End

Part No.	Parker No.	Tube Size	Thread Size	Hose Size	Pkg Qty
8248	10343-4-4	1/4 <sup>(-4)</sup>	7/16-20	1/4 <sup>(-4)</sup>	5
8249	10343-6-4	3/8 <sup>(-6)</sup>	9/16-18	1/4 <sup>(-4)</sup>	5
8250	10343-6-6	3/8 <sup>(-6)</sup>	9/16-18	3/8 <sup>(-6)</sup>	5
8251	10343-8-8	1/2 <sup>(-8)</sup>	3/4-16	1/2 <sup>(-8)</sup>	5
8252	10343-10-8	5/8 <sup>(-10)</sup>	7/8-14	1/2 <sup>(-8)</sup>	5
8253	10343-10-10	5/8 <sup>(-10)</sup>	7/8-14	5/8 <sup>(-10)</sup>	5
8254	10343-12-12	3/4 <sup>(-12)</sup>	1-1/16-12	3/4 <sup>(-12)</sup>	5
8288	10343-16-16	1" <sup>(-16)</sup>	1-5/16-12	1" <sup>(-16)</sup>	2
8289	10343-20-20	1-1/4 <sup>(-20)</sup>	1-5/8-12	1-1/4 <sup>(-20)</sup>	2

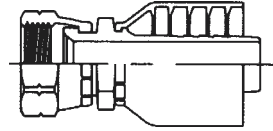

## Female SAE 45° Swivel Hose End

Part No.	Parker No.	Tube Size	Thread Size	Hose Size	Pkg Qty
8213	10843-6-6	3/8 <sup>(-6)</sup>	5/8-18	3/8 <sup>(-6)</sup>	5
8263	10843-12-12	3/4 <sup>(-12)</sup>	1-1/16-14	3/4 <sup>(-12)</sup>	3

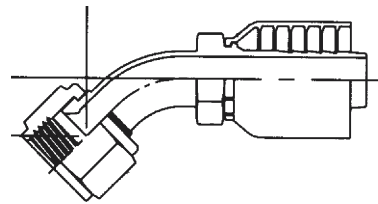

## Female JIC 37° Swivel 45° Elbow Hose End

Part No.	Parker No.	Tube Size	Thread Size	Hose Size	Pkg Qty
8264	13743-4-4	1/4 <sup>(-4)</sup>	7/16-20	1/4 <sup>(-4)</sup>	3
8265	13743-6-6	3/8 <sup>(-6)</sup>	9/16-18	3/8 <sup>(-6)</sup>	3
8266	13743-8-6	1/2 <sup>(-8)</sup>	3/4-16	3/8 <sup>(-6)</sup>	2
8267	13743-8-8	1/2 <sup>(-8)</sup>	3/4-16	1/2 <sup>(-8)</sup>	2

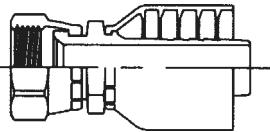

## Female JIC 37° Swivel Hose End

Part No.	Parker No.	Tube Size	Thread Size	Hose Size	Pkg Qty
8205	10643-4-4	1/4 <sup>(-4)</sup>	7/16-20	1/4 <sup>(-4)</sup>	5
8255	10643-5-4	5/16 <sup>(-5)</sup>	1/2-20	1/4 <sup>(-4)</sup>	5
8256	10643-6-4	3/8 <sup>(-6)</sup>	9/16-18	1/4 <sup>(-4)</sup>	5
8206	10643-6-6	3/8 <sup>(-6)</sup>	9/16-18	3/8 <sup>(-6)</sup>	5
8257	10643-8-6	1/2 <sup>(-8)</sup>	3/4-16	3/8 <sup>(-6)</sup>	5
8207	10643-8-8	1/2 <sup>(-8)</sup>	3/4-16	1/2 <sup>(-8)</sup>	5
8258	10643-10-8	5/8 <sup>(-10)</sup>	7/8-14	1/2 <sup>(-8)</sup>	5
8259	10643-12-10	3/4 <sup>(-12)</sup>	1-1/16-12	5/8 <sup>(-10)</sup>	5
8260	10643-10-12	5/8 <sup>(-10)</sup>	7/8-14	3/4 <sup>(-12)</sup>	3
8208	10643-12-12	3/4 <sup>(-12)</sup>	1-1/16-12	3/4 <sup>(-12)</sup>	3
8261	10643-14-12	7/8 <sup>(-14)</sup>	1-3/16-12	3/4 <sup>(-12)</sup>	3
8262	10643-16-12	1" <sup>(-16)</sup>	1-5/16-12	3/4 <sup>(-12)</sup>	3
8209	10643-16-16	1" <sup>(-16)</sup>	1-5/16-12	1" <sup>(-16)</sup>	2
8215	10643-20-20	1-1/4 <sup>(-20)</sup>	1-5/8-12	1-1/4 <sup>(-20)</sup>	2

\* Swivel nuts will connect to either 37° (JIC) or 45° (SAE) flared male fittings

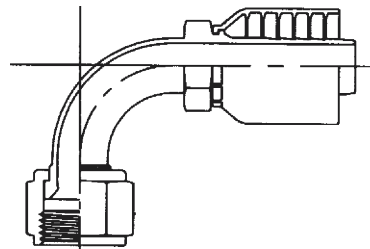

## Female JIC 37° Swivel 90° Elbow Hose End

Part No.	Parker No.	Tube Size	Thread Size	Hose Size	Pkg Qty
8269	13943-4-4	1/4 <sup>(-4)</sup>	7/16-20	1/4 <sup>(-4)</sup>	3
8270	13943-6-6	3/8 <sup>(-6)</sup>	9/16-18	3/8 <sup>(-6)</sup>	3
8271	13943-8-6	1/2 <sup>(-8)</sup>	3/4-16	3/8 <sup>(-6)</sup>	2
8272	13943-8-8	1/2 <sup>(-8)</sup>	3/4-16	1/2 <sup>(-8)</sup>	2
8273	13943-12-12	3/4 <sup>(-12)</sup>	1-1/16-12	3/4 <sup>(-12)</sup>	2
8274	13943-16-16	1" <sup>(-16)</sup>	1-5/16-12	1" <sup>(-16)</sup>	2

# Parker 43 Series Crimp Fittings

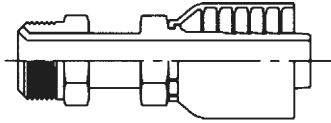

## Straight Tube Male Swivel 45° Inverted Flare Hose End

Part No.	Parker No.	Tube Size	Thread Size	Hose Size	Pkg Qty
8275	12843-4-4	1/4 <sup>(-4)</sup>	7/16-24	1/4 <sup>(-4)</sup>	3
8276	12843-6-6	3/8 <sup>(-6)</sup>	5/8-18	3/8 <sup>(-6)</sup>	3

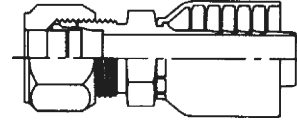

## Ferrule Fix SAE Flareless Hose End

*Fast Repair For Ruptured "Straight of Bent Tube" Hose Assemblies & Power Steering Lines.*

Part No.	Parker No.	Tube Size	Hose Size	Pkg Qty
8281	11143-4-4	1/4 <sup>(-4)</sup>	1/4 <sup>(-6)</sup>	3
8282	11143-6-6	3/8 <sup>(-6)</sup>	3/8 <sup>(-6)</sup>	3
8283	11143-8-8	1/2 <sup>(-8)</sup>	1/2 <sup>(-8)</sup>	3
8284	11143-10-8	5/8 <sup>(-10)</sup>	1/2 <sup>(-8)</sup>	2
8285	11143-12-12	3/4 <sup>(-12)</sup>	3/4 <sup>(-12)</sup>	2

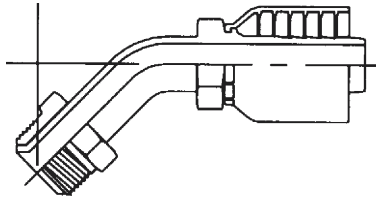

## 45° Bent Tube Male Swivel 45° Inverted Flare Hose End

Part No.	Parker No.	Tube Size	Thread Size	Hose Size	Pkg Qty
8277	16743-4-4	1/4 <sup>(-4)</sup>	7/16-24	1/4 <sup>(-4)</sup>	3
8278	16743-6-6	3/8 <sup>(-6)</sup>	5/8-18	3/8 <sup>(-6)</sup>	3

## Parker Hose Fitting Assortments

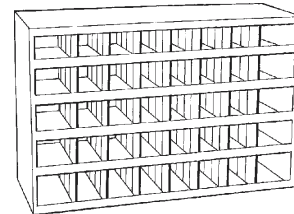

### COMPLETE ASSORTMENT

27 SIZES, 1/4", 3/8", 1/2", 3/4" AND 1" O.D. HOSE ENDS  
ELBOWS AND SWIVEL ADAPTERS IN  
A STEEL 40-HOLE BIN. **PART NO. 40-105**

### ECONOMY ASSORTMENT

20 SIZES, 1/4", 3/8" AND 1/2" O.D. HOSE ENDS  
ELBOWS AND SWIVEL ADAPTERS IN  
A STEEL 40-HOLE BIN. **PART NO. 40-106**

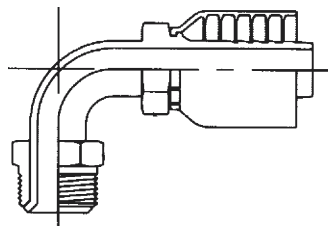

## 90° Bent Tube Male Swivel 45° Inverted Flare Hose End

Part No.	Parker No.	Tube Size	Thread Size	Hose Size	Pkg Qty
8279	16943-4-4	1/4 <sup>(-4)</sup>	7/16-24	1/4 <sup>(-4)</sup>	3
8280	16943-6-6	3/8 <sup>(-6)</sup>	5/8-18	3/8 <sup>(-6)</sup>	3

**When I die, I want to go peacefully,  
like my grandfather did...in his sleep.  
Not screaming like the other  
passengers in his car.**



# Parker 43 Series Crimp Fittings

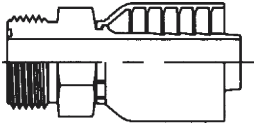

## Male "Seal Lok" - Straight Hose End

O-Ring Face Seal

Part No.	Parker No.	Tube Size	Thread Size	Hose Size	Pkg Qty
8290	1JM43-6-6	3/8 <sup>(-6)</sup>	11/16-16	3/8 <sup>(-6)</sup>	5
8291	1JM43-8-8	1/2 <sup>(-8)</sup>	13/16-16	1/2 <sup>(-8)</sup>	5

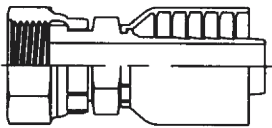

## Female "Seal-Lok" Swivel\* Straight Hose End

Part No.	Parker No.	Tube Size	Thread Size	Hose Size	Pkg Qty
8292	1JC43-6-6	3/8 <sup>(-6)</sup>	11/16-16	3/8 <sup>(-6)</sup>	5
8293	1JC43-8-8	1/2 <sup>(-8)</sup>	13/16-16	1/2 <sup>(-8)</sup>	5

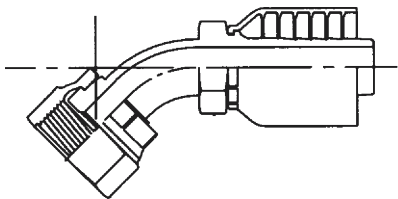

## Female "Seal-Lok" Swivel\* 45° Elbow Hose End

Part No.	Parker No.	Tube Size	Thread Size	Hose Size	Pkg Qty
8294	1J743-6-6	3/8 <sup>(-6)</sup>	11/16-16	3/8 <sup>(-6)</sup>	5
8295	1J743-8-8	1/2 <sup>(-8)</sup>	13/16-16	1/2 <sup>(-8)</sup>	5

\*FEMALE SWIVEL NUT TORQUE (non-lubricated) 3/8 tube size; 24-30 ft lbs., 1/2 tube size; 34-42 ft lbs.

# Quarter Turn Crimp Fittings



Two-Lug Quarter Turn Hose Ends designed for use with 3/4" i.d. contractor air hose (#4790). Also called "Crowfoot" fittings.

Part No.	Dixon No.	Hose I.D.	Pkg Qty
8300	AM6WF	3/4" <sup>(-12)</sup>	1

\*NOTE - this is not a Parker item. Parker Parkrimp system users should contact our hose crimping department for more information on crimping this fitting with a Parker hose crimp machine.

# Adapters

Material: Zinc Plated Steel



## Male "Seal-Lok" to Male Pipe Straight Adapter

O-Ring Face Seal

Part No.	Parker No.	Tube Size	Thread Size	Pipe Size	Pkg Qty
8296	6-6FLO-S	3/8 <sup>(-6)</sup>	11/16-16	3/8-18 <sup>(-6)</sup>	5
8297	8-8FLO-S	1/2 <sup>(-8)</sup>	13/16-16	1/2-14 <sup>(-8)</sup>	5

*I'm not into working out.  
My philosophy: No pain, no pain.*

# Adapters

Material: Zinc Plated Steel

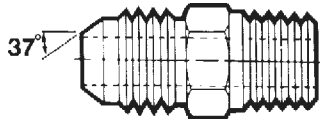

## Straight Adapter JIC 37° Male Flare to Male Pipe

Part No.	Pipe Thread	Tube O.D.	Thread Size	Pkg Qty
5200	1/8-27 <sup>(-2)</sup>	1/4 <sup>(-4)</sup>	7/16-20	5
5201	1/8-27 <sup>(-2)</sup>	5/16 <sup>(-5)</sup>	1/2-20	5
5202	1/8-27 <sup>(-2)</sup>	3/8 <sup>(-6)</sup>	9/16-18	5
5203	1/4-18 <sup>(-4)</sup>	1/4 <sup>(-4)</sup>	7/16-20	5
5204	1/4-18 <sup>(-4)</sup>	5/16 <sup>(-5)</sup>	1/2-20	5
5205	1/4-18 <sup>(-4)</sup>	3/8 <sup>(-6)</sup>	9/16-18	5
5206	3/8-18 <sup>(-6)</sup>	1/4 <sup>(-4)</sup>	7/16-20	5
5207	3/8-18 <sup>(-6)</sup>	5/16 <sup>(-5)</sup>	1/2-20	5
5208	3/8-18 <sup>(-6)</sup>	3/8 <sup>(-6)</sup>	9/16-18	5
5209	3/8-18 <sup>(-6)</sup>	1/2 <sup>(-8)</sup>	3/4-16	5
5210	1/2-14 <sup>(-8)</sup>	3/8 <sup>(-6)</sup>	9/16-18	5
5211	1/2-14 <sup>(-8)</sup>	1/2 <sup>(-8)</sup>	3/4-16	5
5212	1/2-14 <sup>(-8)</sup>	5/8 <sup>(-10)</sup>	7/8-12	5
5213	1/2-14 <sup>(-8)</sup>	3/4 <sup>(-12)</sup>	1-1/16-12	2
5214	3/4-14 <sup>(-12)</sup>	1/2 <sup>(-8)</sup>	3/4-16	2
5215	3/4-14 <sup>(-12)</sup>	5/8 <sup>(-10)</sup>	7/8-14	2
5216	3/4-14 <sup>(-12)</sup>	3/4 <sup>(-12)</sup>	1-1/16-12	2
5217	3/4-14 <sup>(-12)</sup>	1 <sup>(-16)</sup>	1-5/16-12	2
5218	1-11/2 <sup>(-16)</sup>	3/4 <sup>(-12)</sup>	1-1/16-12	2
5219	1-11/2 <sup>(-16)</sup>	1 <sup>(-16)</sup>	1-5/16-12	2
5220	1-1/4-11 1/2 <sup>(-20)</sup>	1-1/4 <sup>(-20)</sup>	1-5/8-12	1
5221	1-1/2-11 1/2 <sup>(-20)</sup>	1-1/2 <sup>(-24)</sup>	1-7/8-12	1
5222	2-11/2 <sup>(-32)</sup>	2 <sup>(-32)</sup>	2-1/2-12	1

WEATHERHEAD SERIES C5205  
DAYCO SERIES 2404

**If you need it  
and don't see it  
ASK US!**

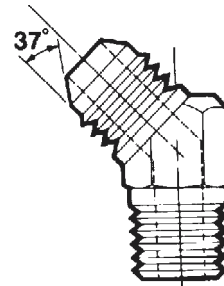

## 45° Elbow JIC 37° Male Flare to Male Pipe

Part No.	Pipe Thread	Tube O.D.	Thread Size	Pkg Qty
5236	1/8-27 <sup>(-2)</sup>	1/4 <sup>(-4)</sup>	7/16-20	5
5237	1/4-18 <sup>(-4)</sup>	1/4 <sup>(-4)</sup>	7/16-20	5
5238	1/4-18 <sup>(-4)</sup>	3/8 <sup>(-6)</sup>	9/16-18	5
5239	3/8-18 <sup>(-6)</sup>	3/8 <sup>(-6)</sup>	9/16-18	5
5240	3/8-18 <sup>(-6)</sup>	1/2 <sup>(-8)</sup>	3/4-16	2
5241	1/2-14 <sup>(-8)</sup>	3/8 <sup>(-6)</sup>	9/16-18	2
5242	1/2-14 <sup>(-8)</sup>	1/2 <sup>(-8)</sup>	3/4-16	2
5243	1/2-14 <sup>(-8)</sup>	5/8 <sup>(-10)</sup>	7/8-14	2
5244	3/4-14 <sup>(-12)</sup>	5/8 <sup>(-10)</sup>	7/8-14	2
5245	3/4-14 <sup>(-12)</sup>	3/4 <sup>(-12)</sup>	1-1/16-12	2
5246	1-11 1/2 <sup>(-16)</sup>	1 <sup>(-16)</sup>	1-5/16-12	2

WEATHERHEAD SERIES C5355  
DAYCO SERIES 2503

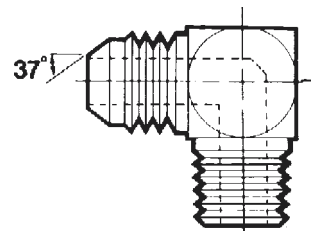

## 90° Elbow JIC 37° Male Flare to Male Pipe

Part No.	Pipe Thread	Tube O.D.	Thread Size	Pkg Qty
5247	1/8-27 <sup>(-2)</sup>	1/4 <sup>(-4)</sup>	7/16-20	5
5248	1/4-18 <sup>(-4)</sup>	1/4 <sup>(-4)</sup>	7/16-20	5
5249	1/4-18 <sup>(-4)</sup>	3/8 <sup>(-6)</sup>	9/16-18	5
5250	3/8-18 <sup>(-6)</sup>	3/8 <sup>(-6)</sup>	9/16-18	5
5251	3/8-18 <sup>(-6)</sup>	1/2 <sup>(-8)</sup>	3/4-16	2
5252	1/2-14 <sup>(-8)</sup>	3/8 <sup>(-6)</sup>	9/16-18	2
5253	1/2-14 <sup>(-8)</sup>	1/2 <sup>(-8)</sup>	3/4-16	2
5254	1/2-14 <sup>(-8)</sup>	5/8 <sup>(-10)</sup>	7/8-14	2
5255	3/4-14 <sup>(-12)</sup>	5/8 <sup>(-10)</sup>	7/8-14	2
5256	3/4-14 <sup>(-12)</sup>	3/4 <sup>(-12)</sup>	1-1/16-12	2
5257	1-11 1/2 <sup>(-16)</sup>	1 <sup>(-16)</sup>	1-5/16-12	2

WEATHERHEAD SERIES C5405  
DAYCO SERIES 2501



# Adapters

Material: Zinc Plated Steel

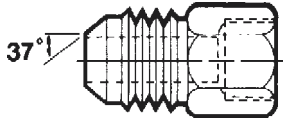

## Straight Adapter JIC 37° Male Flare to Female Pipe

Part No.	Pipe Thread	Tube O.D.	Thread Size	Pkg Qty
5223	1/8-27 <sup>(-2)</sup>	1/4 <sup>(-4)</sup>	7/16-20	5
5224	1/4-18 <sup>(-4)</sup>	1/4 <sup>(-4)</sup>	7/16-20	5
5225	1/4-18 <sup>(-4)</sup>	3/8 <sup>(-6)</sup>	9/16-18	5
5226	3/8-18 <sup>(-6)</sup>	3/8 <sup>(-6)</sup>	9/16-18	5
5227	3/8-18 <sup>(-6)</sup>	1/2 <sup>(-8)</sup>	3/4-16	5
5228	1/2-14 <sup>(-8)</sup>	3/8 <sup>(-6)</sup>	9/16-18	2
5229	1/2-14 <sup>(-8)</sup>	1/2 <sup>(-8)</sup>	3/4-16	2
5230	1/2-14 <sup>(-8)</sup>	5/8 <sup>(-10)</sup>	7/8-14	2
5231	1/2-14 <sup>(-8)</sup>	3/4 <sup>(-12)</sup>	1-1/16-12	2
5232	3/4-14 <sup>(-12)</sup>	1/2 <sup>(-8)</sup>	3/4-16	2
5233	3/4-14 <sup>(-12)</sup>	5/8 <sup>(-10)</sup>	7/8-14	2
5234	3/4-14 <sup>(-12)</sup>	3/4 <sup>(-12)</sup>	1-1/16-12	2
5235	1-11 1/2 <sup>(-16)</sup>	1" <sup>(-16)</sup>	1-5/16-12	2

WEATHERHEAD SERIES C5255  
DAYCO SERIES 2405

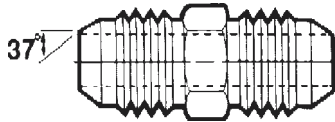

## JIC 37° Male Flare Union

Part No.	Tube O.D.	Thread Size	Pkg Qty
5258	1/4 <sup>(-4)</sup>	7/16-20	10
5259	3/8 <sup>(-6)</sup>	9/16-18	10
5260	1/2 <sup>(-8)</sup>	3/4-16	5
5261	5/8 <sup>(-10)</sup>	7/8-14	5
5262	3/4 <sup>(-12)</sup>	1-1/16-12	2
5263	1" <sup>(-16)</sup>	1-5/16-12	2

WEATHERHEAD SERIES C5305  
DAYCO SERIES 2403

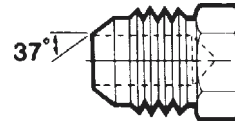

## JIC 37° Male Flare Plug

Part No.	Tube O.D.	Thread Size	Pkg Qty
5356	1/4 <sup>(-8)</sup>	7/16-20	5
5357	5/16 <sup>(-5)</sup>	1/2-20	5
5358	3/8 <sup>(-6)</sup>	9/16-18	5
5359	1/2 <sup>(-8)</sup>	3/4-16	5
5360	5/8 <sup>(-10)</sup>	7/8-14	5
5361	3/4 <sup>(-12)</sup>	1-1/16-12	5
5362	7/8 <sup>(-14)</sup>	1-3/16-12	2
5363	1" <sup>(-16)</sup>	1-5/16-12	2

WEATHERHEAD SERIES C5229  
DAYCO SERIES 2408

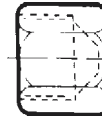

## JIC 37° Flare Cap

Part No.	Tube O.D.	Thread Size	Pkg Qty
5364	1/4 <sup>(-4)</sup>	7/16-20	5
5365	5/16 <sup>(-5)</sup>	1/2-20	5
5366	3/8 <sup>(-6)</sup>	9/16-18	5
5367	1/2 <sup>(-8)</sup>	3/4-16	5
5368	5/8 <sup>(-10)</sup>	7/8-14	5
5369	3/4 <sup>(-12)</sup>	1-1/16-12	5
5370	7/8 <sup>(-14)</sup>	1-3/16-12	2
5371	1" <sup>(-16)</sup>	1-5/16-12	2

WEATHERHEAD SERIES C5129  
DAYCO SERIES 304C

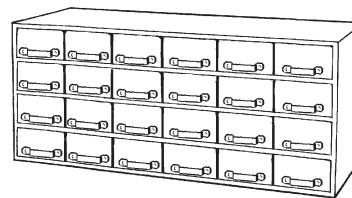

*Let MPI "customize" an assortment  
that fits your needs!*



# Adapters

Material: Zinc Plated Steel

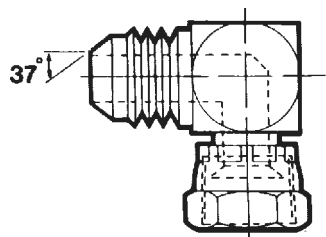

## JIC 37° Flare - Male to Female Swivel 90° Elbow

Part No.	Tube O.D.	Thread Size	Pkg Qty
5386	1/4 <sup>(-4)</sup>	7/16-20	5
5387	3/8 <sup>(-6)</sup>	9/16-18	5
5388	1/2 <sup>(-8)</sup>	3/4-16	2
5389	5/8 <sup>(-10)</sup>	7/8-14	2
5390	3/4 <sup>(-12)</sup>	1-1/16-12	2

WEATHERHEAD SERIES C5506  
DAYCO SERIES 6500

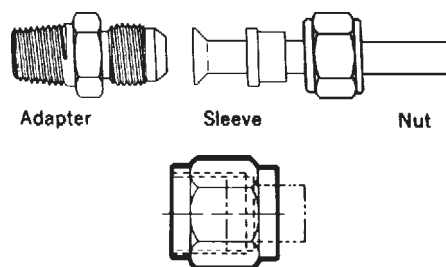

## Tubing Nut

Part No.	Tube O.D.	Thread Size	Pkg Qty
5372	1/4 <sup>(-4)</sup>	7/16-20	10
5373	5/16 <sup>(-6)</sup>	1/2-20	10
5374	3/8 <sup>(-6)</sup>	9/16-18	10
5375	1/2 <sup>(-8)</sup>	3/4-16	10
5376	5/8 <sup>(-10)</sup>	7/8-14	5
5377	3/4 <sup>(-12)</sup>	1-1/16-12	5
5378	1 <sup>(-16)</sup>	1-5/16-12	5

WEATHERHEAD SERIES C5105  
DAYCO SERIES 302

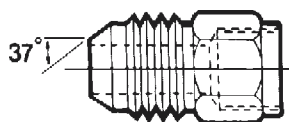

## JIC 37° Flare - Male to Female Rigid Flare Reducer

Part No.	MALE		FEMALE		Pkg Qty
	Thrd. Size	Tube O.D.	Thread Size	Tube O.D.	
13-449	9/16-18	3/8 <sup>(-6)</sup>	7/16-20	1/4 <sup>(-4)</sup>	5
13-450	3/4-16	1/2 <sup>(-8)</sup>	7/16-20	1/4 <sup>(-4)</sup>	5
13-451	3/4-16	1/2 <sup>(-8)</sup>	9/16-18	3/8 <sup>(-6)</sup>	5
13-452	7/8-14	5/8 <sup>(-10)</sup>	9/16-18	3/8 <sup>(-6)</sup>	2
13-453	7/8-14	5/8 <sup>(-10)</sup>	3/4-16	1/2 <sup>(-8)</sup>	2
13-454	1-1/16-12	3/4 <sup>(-12)</sup>	3/4-16	1/2 <sup>(-8)</sup>	2

DAYCO SERIES 2406

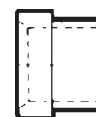

## Tubing Sleeve

Part No.	Tube O.D.	Pkg Qty
5379	1/4 <sup>(-4)</sup>	10
5380	5/16 <sup>(-5)</sup>	10
5381	3/8 <sup>(-6)</sup>	10
5382	1/2 <sup>(-8)</sup>	10
5383	5/8 <sup>(-10)</sup>	5
5384	3/4 <sup>(-12)</sup>	5
5385	1 <sup>(-16)</sup>	5

WEATHERHEAD SERIES C5165  
DAYCO SERIES 319

*I have six locks on my door all in a row. When I go out, I lock every other one. I figure no matter how long somebody stands there picking the locks, they are always locking three.*



# Adapters

Material: Zinc Plated Steel

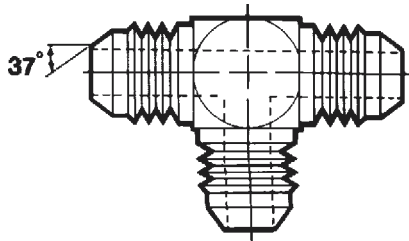

**Union Tee**  
**JIC 37° Male Flare**

Part No.	Tube O.D.	Thread Size	Pkg Qty
13-455	1/4 <sup>(-4)</sup>	7/16-20	2
13-456	5/16 <sup>(-5)</sup>	1/2-20	2
13-457	3/8 <sup>(-6)</sup>	9/16-18	2
13-458	1/2 <sup>(-8)</sup>	3/4-16	2

DAYCO SERIES 2603

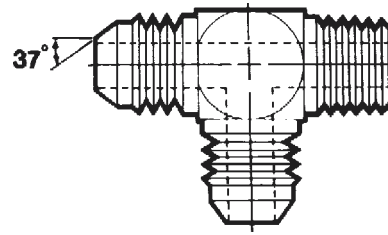

**Male Run Tee**  
**JIC 37° Male Flare to Male Pipe**

Part No.	Tube O.D.	Straight O-Ring	Female Pipe	Pkg Qty
13-467	1/4 <sup>(-4)</sup>	7/16-20	1/8-27 <sup>(-2)</sup>	2
13-468	1/4 <sup>(-4)</sup>	7/16-20	1/4-18 <sup>(-4)</sup>	2
13-469	5/16 <sup>(-5)</sup>	1/2-20	1/8-27 <sup>(-2)</sup>	2
13-470	3/8 <sup>(-6)</sup>	9/16-18	1/4-18 <sup>(-4)</sup>	2
13-471	3/8 <sup>(-6)</sup>	9/16-18	3/8-18 <sup>(-6)</sup>	2
13-472	1/2 <sup>(-8)</sup>	3/4-16	3/8-18 <sup>(-6)</sup>	2
13-473	1/2 <sup>(-8)</sup>	3/4-16	1/2-14 <sup>(-8)</sup>	2

DAYCO SERIES 2605

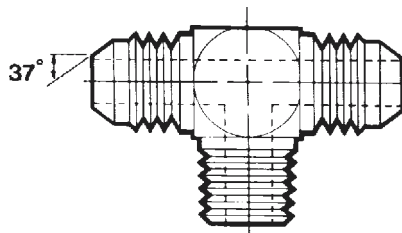

**Branch Tee**  
**JIC 37° Male Flare to Male Pipe**

Part No.	Tube O.D.	Straight O-Ring	Female Pipe	Pkg Qty
13-459	1/4 <sup>(-4)</sup>	7/16-20	1/8-27 <sup>(-2)</sup>	2
13-460	1/4 <sup>(-4)</sup>	7/16-20	1/4-18 <sup>(-4)</sup>	2
13-461	5/16 <sup>(-5)</sup>	1/2-20	1/8-27 <sup>(-2)</sup>	2
13-462	5/16 <sup>(-5)</sup>	1/2-20	1/4-18 <sup>(-4)</sup>	2
13-463	3/8 <sup>(-6)</sup>	9/16-18	1/4-18 <sup>(-4)</sup>	2
13-464	3/8 <sup>(-6)</sup>	9/16-18	3/8-18 <sup>(-6)</sup>	2
13-465	1/2 <sup>(-8)</sup>	3/4-16	3/8-18 <sup>(-6)</sup>	2
13-466	1/2 <sup>(-8)</sup>	3/4-16	1/2-14 <sup>(-8)</sup>	2

DAYCO SERIES 2601



**ASK FOR YOUR  
FREE WRIGHT TOOL  
CATALOG!**

# Adapters

Material: Zinc Plated Steel

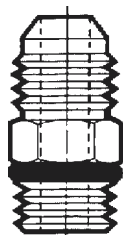

## Male ORB\* Connector to 37° Flare

Part No.	Tube O.D.	Thread Size	O-Ring Thread	Pkg Qty
4840	1/4 <sup>(-4)</sup>	7/16-20	7/16-20 <sup>(-4)</sup>	5
4841	1/4 <sup>(-4)</sup>	7/16-20	1/2-20 <sup>(-5)</sup>	5
4842	5/16 <sup>(-5)</sup>	1/2-20	1/2-20 <sup>(-5)</sup>	5
4843	3/8 <sup>(-6)</sup>	9/16-18	9/16-18 <sup>(-6)</sup>	5
4844	3/8 <sup>(-6)</sup>	9/16-18	3/4-16 <sup>(-8)</sup>	5
4845	1/2 <sup>(-8)</sup>	3/4-16	3/4-16 <sup>(-8)</sup>	5
4846	1/2 <sup>(-8)</sup>	3/4-16	9/16-18 <sup>(-6)</sup>	5
4847	1/2 <sup>(-8)</sup>	3/4-16	7/8-14 <sup>(-10)</sup>	5
4848	1/2 <sup>(-8)</sup>	3/4-16	1-1/16-12 <sup>(-12)</sup>	5
4849	5/8 <sup>(-10)</sup>	7/8-14	7/8-14 <sup>(-10)</sup>	5
4850	5/8 <sup>(-10)</sup>	7/8-14	3/4-16 <sup>(-8)</sup>	5
4851	5/8 <sup>(-10)</sup>	7/8-14	1-1/16-12 <sup>(-12)</sup>	5
4852	3/4 <sup>(-12)</sup>	1-1/16-12	1-1/16-12 <sup>(-12)</sup>	2
4853	3/4 <sup>(-12)</sup>	1-1/16-12	3/4-16 <sup>(-8)</sup>	2
4854	7/8 <sup>(-14)</sup>	1-3/16-12	1-3/16-12 <sup>(-14)</sup>	2
4855	1" <sup>(-16)</sup>	1-5/16-12	1-5/16-12 <sup>(-16)</sup>	2
4856	1" <sup>(-16)</sup>	1-5/16-12	1-1/16-12 <sup>(-12)</sup>	2

WEATHERHEAD SERIES 5315  
DAYCO SERIES 6400

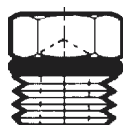

## Plug ORB\*

Part No.	O-Ring Thread	Pkg Qty
4863	7/16-20 <sup>(-4)</sup>	5
4864	1/2-20 <sup>(-5)</sup>	5
4865	9/16-18 <sup>(-6)</sup>	5
4866	3/4-16 <sup>(-8)</sup>	5
4867	7/8-14 <sup>(-10)</sup>	2
4868	1-1/16-12 <sup>(-12)</sup>	2
4869	1-5/16-12 <sup>(-16)</sup>	2

WEATHERHEAD SERIES 7237  
DAYCO SERIES 6408

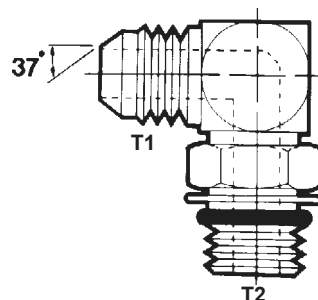

## 90° Adjustable Elbow ORB\* to 37° Flare

Part No.	Tube O.D.	Tube Thread T1	O-Ring Thread T2	Pkg Qty
4857	1/4	7/16-20 <sup>(-4)</sup>	7/16-20 <sup>(-4)</sup>	5
13-474	1/4	7/16-20 <sup>(-4)</sup>	1/2-20 <sup>(-5)</sup>	5
13-475	1/4	7/16-20 <sup>(-4)</sup>	9/16-18 <sup>(-6)</sup>	5
13-476	1/4	7/16-20 <sup>(-4)</sup>	3/4-16 <sup>(-8)</sup>	5
13-477	5/16	1/2-20 <sup>(-5)</sup>	7/16-20 <sup>(-4)</sup>	5
13-478	5/16	1/2-20 <sup>(-5)</sup>	1/2-20 <sup>(-5)</sup>	5
13-479	5/16	1/2-20 <sup>(-5)</sup>	9/16-18 <sup>(-6)</sup>	5
13-480	3/8	9/16-18 <sup>(-6)</sup>	7/16-20 <sup>(-4)</sup>	5
13-481	3/8	9/16-18 <sup>(-6)</sup>	1/2-20 <sup>(-5)</sup>	2
4858	3/8	9/16-18 <sup>(-6)</sup>	9/16-18 <sup>(-6)</sup>	2
13-482	3/8	9/16-18 <sup>(-6)</sup>	3/4-16 <sup>(-8)</sup>	2
13-483	3/8	9/16-18 <sup>(-6)</sup>	7/8-14 <sup>(-10)</sup>	2
13-484	1/2	3/4-16 <sup>(-8)</sup>	9/16-18 <sup>(-6)</sup>	2
4859	1/2	3/4-16 <sup>(-8)</sup>	3/4-16 <sup>(-8)</sup>	2
13-485	1/2	3/4-16 <sup>(-8)</sup>	7/8-14 <sup>(-10)</sup>	2
13-486	1/2	3/4-16 <sup>(-8)</sup>	1-1/16-12 <sup>(-12)</sup>	2
13-487	5/8	7/8-14 <sup>(-10)</sup>	3/4-16 <sup>(-8)</sup>	2
4860	5/8	7/8-14 <sup>(-10)</sup>	7/8-14 <sup>(-10)</sup>	2
13-488	5/8	7/8-14 <sup>(-10)</sup>	1-1/16-12 <sup>(-12)</sup>	2
13-489	3/4	1-1/16-12 <sup>(-12)</sup>	7/8-14 <sup>(-10)</sup>	1
4861	3/4	1-1/16-12 <sup>(-12)</sup>	1-1/16-12 <sup>(-12)</sup>	1
4862	1"	1-5/16-12 <sup>(-16)</sup>	1-5/16-12 <sup>(-16)</sup>	1

WEATHERHEAD SERIES 5515  
DAYCO SERIES 6801

Did you ever notice when you blow in a dog's face he gets mad at you? But when you take him in a car he sticks his head out the window?

\*O-Ring Boss Thread



# Adapters

Material: Zinc Plated Steel

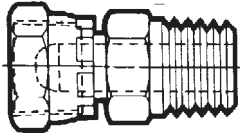

## Pipe Adapter - Straight NPTF Male to NPSM Swivel Female

Part No.	Female Pipe Thread	Male Pipe Thread	Pkg Qty
5264	1/8-27 <sup>(-2)</sup>	1/8-27 <sup>(-2)</sup>	5
5265	1/8-27 <sup>(-2)</sup>	1/4-18 <sup>(-4)</sup>	5
5336	1/4-18 <sup>(-4)</sup>	1/8-27 <sup>(-2)</sup>	5
5266	1/4-18 <sup>(-4)</sup>	1/4-18 <sup>(-4)</sup>	5
5337	3/8-18 <sup>(-6)</sup>	1/4-18 <sup>(-4)</sup>	5
5267	3/8-18 <sup>(-6)</sup>	3/8-18 <sup>(-6)</sup>	5
5268	3/8-18 <sup>(-6)</sup>	1/2-14 <sup>(-8)</sup>	5
5269	1/2-14 <sup>(-8)</sup>	3/8-18 <sup>(-6)</sup>	5
5270	1/2-14 <sup>(-8)</sup>	1/2-14 <sup>(-8)</sup>	5
5338	1/2-14 <sup>(-8)</sup>	3/4-14 <sup>(-12)</sup>	5
5339	3/4-14 <sup>(-12)</sup>	1/2-14 <sup>(-8)</sup>	2
5271	3/4-14 <sup>(-12)</sup>	3/4-14 <sup>(-12)</sup>	2
5272	1-11 1/2 <sup>(-16)</sup>	1-11 1/2 <sup>(-16)</sup>	2
5340	1-1/4-11 1/2 <sup>(-20)</sup>	1-1/4-11 1/2 <sup>(-24)</sup>	2
5341	1-1/2-11 1/2 <sup>(-24)</sup>	1-1/2-11 1/2 <sup>(-24)</sup>	2
5342	2-11 1/2 <sup>(-32)</sup>	2-11 1/2 <sup>(-32)</sup>	2

WEATHERHEAD SERIES 9205  
DAYCO SERIES 1404

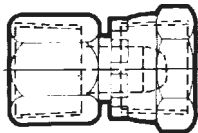

## Pipe Adapter - Straight NPTF Female to NPSM Swivel Female

Part No.	Rigid Pipe Thread	Swivel Pipe Thread	Pkg Qty
5287	1/4-18 <sup>(-4)</sup>	1/4-18 <sup>(-4)</sup>	5
5288	3/8-18 <sup>(-6)</sup>	3/8-18 <sup>(-6)</sup>	5
5289	1/2-14 <sup>(-8)</sup>	3/8-18 <sup>(-6)</sup>	5
5290	1/2-14 <sup>(-8)</sup>	1/2-14 <sup>(-8)</sup>	2
5291	3/4-14 <sup>(-12)</sup>	3/4-14 <sup>(-12)</sup>	2
5292	1-11 1/2 <sup>(-16)</sup>	1-11 1/2 <sup>(-16)</sup>	2

WEATHERHEAD SERIES 9255  
DAYCO SERIES 1405

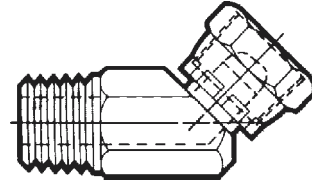

## 45° Pipe Elbow NPTF Male to NPSM Swivel Female

Part No.	Female Pipe Thread	Male Pipe Thread	Pkg Qty
5343	1/8-27 <sup>(-2)</sup>	1/8-27 <sup>(-2)</sup>	2
5273	1/4-18 <sup>(-4)</sup>	1/4-18 <sup>(-4)</sup>	2
5274	3/8-18 <sup>(-6)</sup>	3/8-18 <sup>(-6)</sup>	2
5275	3/8-18 <sup>(-6)</sup>	1/2-14 <sup>(-8)</sup>	2
5276	1/2-14 <sup>(-8)</sup>	3/8-18 <sup>(-6)</sup>	2
5277	1/2-14 <sup>(-8)</sup>	1/2-14 <sup>(-8)</sup>	2
5278	3/4-14 <sup>(-12)</sup>	3/4-14 <sup>(-12)</sup>	2
5279	1-11 1/2 <sup>(-16)</sup>	1-11 1/2 <sup>(-16)</sup>	2
5344	1-1/4-11 1/2 <sup>(-20)</sup>	1-1/4-11 1/2 <sup>(-20)</sup>	2
5345	1-1/2-11 1/2 <sup>(-24)</sup>	1-1/2-11 1/2 <sup>(-24)</sup>	2

WEATHERHEAD SERIES 9355  
DAYCO SERIES 1503

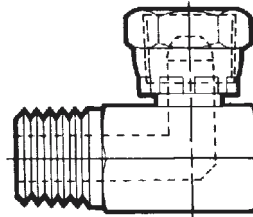

## 90° Pipe Elbow NPTF Male to NPSM Swivel Female

Part No.	Female Pipe Thread	Male Pipe Thread	Pkg Qty
5346	1/8-27 <sup>(-2)</sup>	1/8-27 <sup>(-2)</sup>	2
5280	1/4-18 <sup>(-4)</sup>	1/4-18 <sup>(-4)</sup>	2
5281	3/8-18 <sup>(-6)</sup>	3/8-18 <sup>(-6)</sup>	2
5282	3/8-18 <sup>(-6)</sup>	1/2-14 <sup>(-8)</sup>	2
5283	1/2-14 <sup>(-8)</sup>	3/8-18 <sup>(-6)</sup>	2
5284	1/2-14 <sup>(-8)</sup>	1/2-14 <sup>(-8)</sup>	2
5285	3/4-14 <sup>(12)</sup>	3/4-14 <sup>(-12)</sup>	2
5286	1-11 1/2 <sup>(-16)</sup>	1-11 1/2 <sup>(-16)</sup>	2
5347	1-1/4-11 1/2 <sup>(-20)</sup>	1-1/4-11 1/2 <sup>(-20)</sup>	1
5348	1-1/2-11 1/2 <sup>(-24)</sup>	1-1/2-11 1/2 <sup>(-24)</sup>	1
5349	2-11 1/2 <sup>(-32)</sup>	2-11 1/2 <sup>(-32)</sup>	1

WEATHERHEAD SERIES 9405  
DAYCO SERIES 1501

# Adapters

Material: Zinc Plated Steel

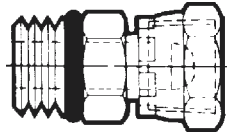

## ORB\* to NPSM Female Swivel

Part No.	Tube O.D.	Straight O-Ring	Female Pipe	Pkg Qty
5297	1/4 <sup>(-4)</sup>	7/16-20	1/4-18 <sup>(-4)</sup>	5
5298	3/8 <sup>(-6)</sup>	9/16-18	1/4-18 <sup>(-4)</sup>	5
5299	3/8 <sup>(-6)</sup>	9/16-18	3/8-18 <sup>(-6)</sup>	5
5391	3/8 <sup>(-6)</sup>	9/16-18	1/2-14 <sup>(-8)</sup>	5
5300	1/2 <sup>(-8)</sup>	3/4-16	3/8-18 <sup>(-6)</sup>	5
5301	1/2 <sup>(-8)</sup>	3/4-16	1/2-14 <sup>(-8)</sup>	5
5302	5/8 <sup>(-10)</sup>	7/8-14	1/2-14 <sup>(-8)</sup>	2
5303	1/2 <sup>(-8)</sup>	3/4-16	3/4-14 <sup>(-12)</sup>	2
5304	5/8 <sup>(-10)</sup>	7/8-14	1/2-14 <sup>(-8)</sup>	2
5305	3/4 <sup>(-12)</sup>	1-1/16-12	3/4-14 <sup>(-12)</sup>	2
5306	1 <sup>(-16)</sup>	1-5/16-12	1-11/2 <sup>(-16)</sup>	2

WEATHERHEAD SERIES 9315  
DAYCO SERIES 6900

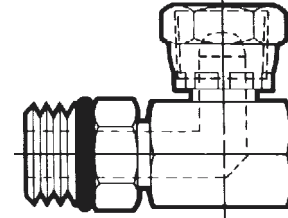

## ORB\* to 90° NPSM Swivel Female

Part No.	Tube O.D.	Straight O-Ring	Female Pipe	Pkg Qty
5313	1/4 <sup>(-4)</sup>	7/16-20	1/4-18 <sup>(-4)</sup>	2
5314	3/8 <sup>(-6)</sup>	9/16-18	3/8-18 <sup>(-6)</sup>	2
5315	1/2 <sup>(-8)</sup>	3/4-16	3/8-18 <sup>(-6)</sup>	2
5316	1/2 <sup>(-8)</sup>	3/4-16	1/2-14 <sup>(-8)</sup>	2
5317	5/8 <sup>(-10)</sup>	7/8-14	1/2-14 <sup>(-8)</sup>	2
5318	1/2 <sup>(-8)</sup>	3/4-16	3/4-14 <sup>(-12)</sup>	1
5319	5/8 <sup>(-10)</sup>	7/8-14	3/4-14 <sup>(-12)</sup>	2
5320	3/4 <sup>(-12)</sup>	1-1/16-12	3/4-14 <sup>(-12)</sup>	2
5321	1 <sup>(-16)</sup>	1-5/16-12	1-11/2 <sup>(-16)</sup>	1

WEATHERHEAD SERIES 9515  
DAYCO SERIES 6901

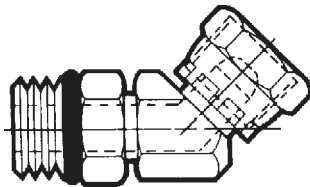

## ORB\* to 45° NPSM Female Elbow

Part No.	Tube O.D.	Straight O-Ring	Female Pipe	Pkg Qty
5307	1/2 <sup>(-8)</sup>	3/4-16	3/8-18 <sup>(-6)</sup>	2
5308	1/2 <sup>(-8)</sup>	3/4-16	1/2-14 <sup>(-8)</sup>	2
5309	5/8 <sup>(-10)</sup>	7/8-14	1/2-14 <sup>(-8)</sup>	2
5310	1/2 <sup>(-8)</sup>	3/4-16	3/4-14 <sup>(-12)</sup>	1
5311	3/4 <sup>(-12)</sup>	1-1/16-12	3/4-14 <sup>(-12)</sup>	2
5312	1 <sup>(-16)</sup>	1-5/16-12	1-11/2 <sup>(-16)</sup>	1

WEATHERHEAD SERIES 9365  
DAYCO SERIES 6902

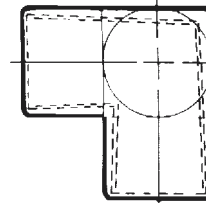

## NPTF Female Pipe 90° Elbow

Part No.	Pipe Thread	Pkg Qty
6433	1/8	2
6434	1/4	2
6435	3/8	2
6436	1/2	2
6437	3/4	2
6438	1"	2

WEATHERHEAD SERIES C3509  
DAYCO SERIES 2202

\*O-Ring Boss Thread



# Adapters

Material: Zinc Plated Steel

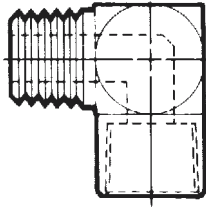

## NPTF 90° Street Elbow

WEATHERHEAD SERIES C3409 • DAYCO SERIES 2102

Part No.	Pipe Thread	Pkg Qty
6439	1/8	2
6440	1/4	2
6441	3/8	2
6442	1/2	2
6443	3/4	2
6444	1"	2

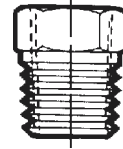

## Hex Bushing NPTF Male to NPTF Female

WEATHERHEAD SERIES C3109 • DAYCO SERIES 0102

Part No.	Pipe Size (Male x Female)	Pkg Qty
6416	1/4 x 1/8	5
6417	3/8 x 1/8	5
6418	3/8 x 1/4	5
6419	1/2 x 1/4	5
6420	1/2 x 3/8	5
6421	3/4 x 3/8	2
6422	3/4 x 1/2	2
6423	1 x 1/2	2
6424	1 x 3/4	2
6425	1 1/4 x 1	2
6426	1 1/2 x 1 1/4	2

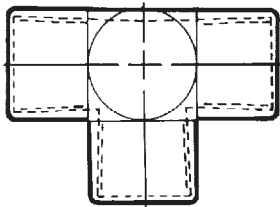

## NPTF Female Pipe Tee

WEATHERHEAD SERIES C3709 • DAYCO SERIES 022T

Part No.	Pipe Thread	Pkg Qty
6445	1/8	2
6446	1/4	2
6447	3/8	2
6448	1/2	2
6449	3/4	2
6450	1"	2

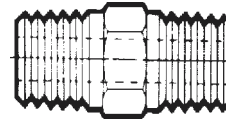

## NPTF Male Hex Nipple

WEATHERHEAD SERIES C3069 • DAYCO SERIES 0101

Part No.	Pipe Thread	Pkg Qty
6406	1/8	5
6407	1/4	5
6408	3/8	5
6409	3/8 x 1/4	5
6410	1/2	2
6411	1/2 x 1/4	2
6412	1/2 x 3/8	2
6413	3/4	2
6414	3/4 x 1/2	2
6415	1"	2

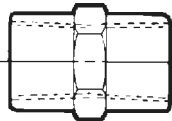

## NPTF Female Coupling

Part No.	Pipe Thread	Pkg Qty
6400	1/8	5
6401	1/4	5
6402	3/8	5
6403	1/2	2
6404	3/4	2
6405	1"	2

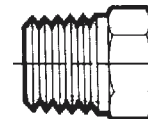

## NPTF Male Hex Plug

Part No.	Pipe Thread	Pkg Qty
6427	1/8	5
6428	1/4	5
6429	3/8	5
6430	1/2	2
6431	3/4	2
6432	1"	2

# Hydraulic Grease Fittings

High pressure ball check in head. Case hardened steel, zinc plated. Meets S.A.E. J-534C specifications.



## 1/4\"/>

Popular on automotive, light truck, and machinery applications due to small thread size.

Part No.	Description	Overall Length	Pkg Qty
3069	Straight Short	35/64	50
3070	Straight Long threads	11/16	25
3071	Straight Long	31/32	25
3072	45° Angle	7/8	25
3073	45° Angle Long thread	1-1/16	25
3074	90° Angle	11/16	25

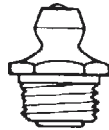

## 1/8\"/>

Thick-wall construction for unequalled strength.

Part No.	Description	Overall Length	Pkg Qty
3050	Straight Short	5/8	50
3051	Straight Long	1-5/16	25
3052	Straight Extra-Long	1-3/4	25
3054	30° Angle	15/16	25
3055	45° Angle	7/8	25
3056	65° Angle	7/8	25
3057	90° Angle	13/16	25

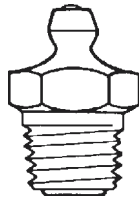

## 1/4\"/>

Widely used for larger bearings on farm machinery and heavy equipment. Recommended for heavy lubricants in cold weather.

Part No.	Description	Overall Length	Pkg Qty
3066	Straight	7/8	25
3067	67½° Angle	1-1/16	25



3/16"



1/4"



5/16"

## DRIVE TYPE

Saves time and simplifies replacement of damaged fittings. For low to medium pressures only.

Part No.	Approx. Drill Size*	Overall Length	Pkg Qty
3080	3/16	1/2	50
3081	1/4	1/2	50
3082	5/16	9/16	50
3105	Drive Fitting Tool, 4" ..... 1		

\*Note: Drill size is approximate. Hole tolerance will vary with material being drilled. A test drilling is highly recommended.



6mm



8mm



10mm

## METRIC SIZES

Part No.	Description	Overall Length	Pkg Qty
STRAIGHT			
3110	M6 x 1.0 pitch	14mm	50
3114	M8 x 1.0 pitch	16mm	50
3117	M10 x 1.0 pitch	19mm	50
45° ANGLE			
3112	M6 x 1.0 pitch	25mm	25
3115	M8 x 1.0 pitch	25mm	25
3118	M10 x 1.0 pitch	25mm	25
90° ANGLE			
3113	M6 x 1.0 pitch	19mm	25
3116	M8 x 1.0 pitch	19mm	25
3119	M10 x 1.0 pitch	19mm	25



## Vinyl Grease Fitting Caps

Keeps grease fittings clean and easy to find. Bright yellow. Pkg: 100 each. **Part No. 3053**



# Hydraulic Grease Fittings

High pressure ball check in head. Case hardened steel, zinc plated. Meets S.A.E. J-534C specifications.

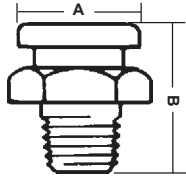

## STANDARD BUTTON HEAD

Industrial applications requiring fast coupling action and full lubricant flow without restriction. Used on conveyors and heavy machinery. Low profile reduces possibility of damage. For pressures to 6,000 psi.

Part No.	Size	"A" Head Dia.	"B" Length	Pkg Qty
3064	1/8 PT	5/8	3/4	10
3083	1/4 PT	5/8	53/64	10
3084	3/8 PT	5/8	61/64	10

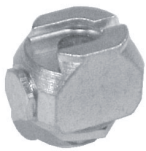

## Standard Button Head Couplers

For use with standard 5/8" diameter button head fittings.

Part No.	Thread Size	Pkg
3135-1	7/16-27 Female	1

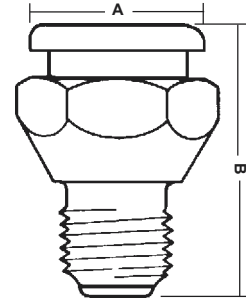

## GIANT BUTTON HEAD

Similar to Standard Button Head, except larger to withstand the roughest usage. Withstands extreme pressures to 15,000 psi. Head diameter: 7/8"

Part No.	Size	"A" Head Dia.	"B" Length	Pkg Qty
3086	1/4 PT	7/8	1-1/4	10
3087	3/8 PT	7/8	1-1/4	10

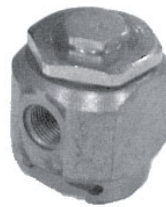

## Giant Button Head Couplers

For use with large 7/8" diameter button head fittings.

Part No.	Thread Size	Pkg
3136-1	7/16-27 Female	1

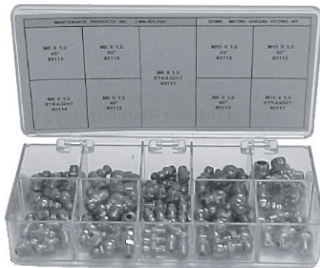

**SMALL GREASE FITTING MAINTENANCE KIT**  
6 SIZES, 1/4-28 AND 1/8 PT IN A PLASTIC BOX  
**PART NO. 521MK**

**LARGE GREASE FITTING MAINTENANCE KIT**  
8 SIZES, 1/4-28 AND 1/8 PT IN A PLASTIC BOX  
**PART NO. 520MK**

**METRIC GREASE FITTING MAINTENANCE KIT**  
9 SIZES, M 6, M8 AND M10 IN A PLASTIC BOX  
**PART NO. 522MK**



## Button Head Coupler Adapter

For adapting standard or larger button head couplers to hose with 1/8" NPT connections.

Part No.	Thread Size	Pkg
3101	7/16-27 male x 1/8 NPT female	1



**GREASE FITTING ASSORTMENT**  
18 SIZES, INCLUDES MOST COMMON 1/4-28 & 1/8 PT FITTINGS, 3/16, 1/4 & 5/16 DRIVE TYPE FITTINGS, M6, M8 & M10 METRIC FITTINGS, & VINYL DUST CAPS IN A LARGE STEEL DRAWER.  
**PART NO. 16-6524**



# Grease Gun Accessories

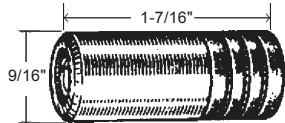

## Standard Grease Gun Couplers

Jaw-type coupler features hardened jaws, Buna-N synthetic rubber seal, and spring loaded check valve. Fits all 1/8" NPT thread. Recommended working pressure: 3000PSI. **Part No. 3103**

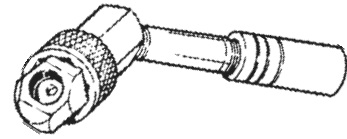

## Swivel Extension with Coupler

Locks in any of eight 45° positions from rigid to right angle. 1/8" NPT. For hard to reach fittings. Standard coupler included. Max. working pressure: 3000PSI. **Part No. 3137**

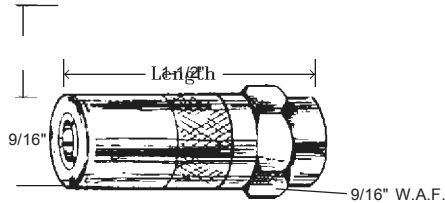

## LINCOLN® Brand

### Standard Grease Gun Coupler

Jaw-type coupler features hardened jaws, Buna-N synthetic rubber seal, and spring loaded check valve. Fits all 1/8" NPT thread. Maximum operating pressure: 6,000PSI. (*Lincoln no. 5852*) **Part No. 3120**

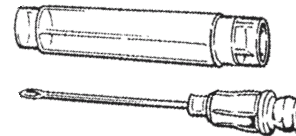

## Grease Injector Needle

Lubricates in very tight places like universal joints and sealed bearings. Tempered stainless steel needle. Equipped with standard grease fitting and protective plastic holder. Length: 2-1/4". **Part No. 3108**

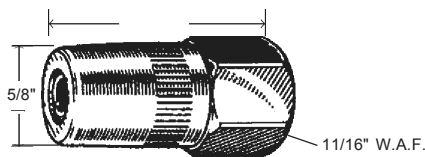

## Heavy Duty Grease Gun Coupler

For heavy duty applications. 1/8 NPT. Recommended working pressure: 4000PSI. **Part No. 3104**



## 4" Needle Nose Adapter

For converting jaw-type lube couplers to steel needle points. Dispenses fine line of grease. Fits all standard couplers with both small and large sleeves. For hand grease guns only. 7-3/4" O.A. Length. **Part No. 3138**

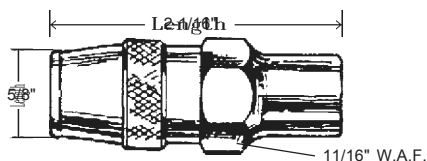

## LINCOLN® Brand

### Heavy Duty Grease Gun Coupler

For heavy duty applications. 1/8 NPT. Maximum operating pressure: 7,500PSI. (*Lincoln no. 5845*) **Part No. 3121**

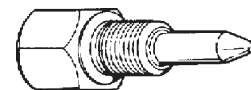

## Needle Nose Dispenser

Dispenses a fine line of grease through the needle nose. 3/4" adapter with 1/8" male and female npt. Use with extension or hose. 1-5/8" O.A. Length. **Part No. 3102**

# Grease Gun Accessories



## Grease Gun Extension

Angle pipe, 6" length, replacement for most hand operated grease guns. **Part No. 3109**



## Standard Grease Hoses

High quality grease hoses with 1/8" npt male fittings at each end. Fits all standard hand grease guns. 1/8" NPT male connection. Working pressure 3,000 psi. Meets us government specification MIL-L-4387C.

*Not for power operated lube equipment*

Part No.	Length	Pkg
3097 .....	12" .....	1
3098 .....	18" .....	1

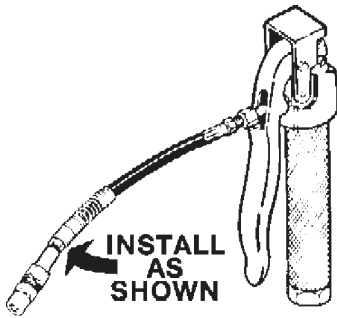

## Lincoln Flex-O-Grip Grease Hoses

Coil spring reinforced for power and hand-operated grease guns. Provides a non-slip, push-pull grip yet prevents accidental "kinking" which can cause ruptures. 1/8" NPT male connection. Working pressure 4500psi.

*Note: install with coil spring near hydraulic coupler*

Part No.	Length	Pkg
3133 .....	12" .....	1
3134 .....	18" .....	1

**WARNING! DO NOT HOLD GREASE HOSE WHILE PUMPING THE GREASE GUN. REPLACE DAMAGED HOSES AT ONCE.**

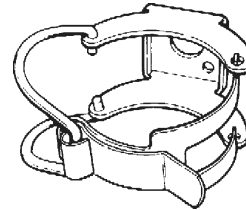

## Grease Gun Holder

Keep your grease guns close at hand. Mounts to walls, vehicles and other machinery. Holds any standard 2-1/4" diameter grease gun. **Part No. 3124**



## Filler Nipples

Enables hand grease guns to be loaded using filler pump method. Includes ball check. 1/8" NPT Male.

Part No.	Thread Size	Nose Dia.	O.A. Length	Hex Size	Style
3122 .....	1/8NPT	11/32	1-1/4	7/16	Small
3123 .....	1/8NPT	9/16	1-3/16	5/8	Large

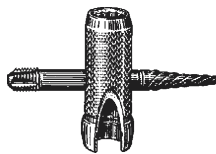

## 4-Way Grease Fitting Tool

Part No.	For Fitting Size	Pkg
3106 .....	1/8 PT	1
3107 .....	1/4-28 SAE	1



# LINCOLN Grease Guns "The Brand the Pros Demand"

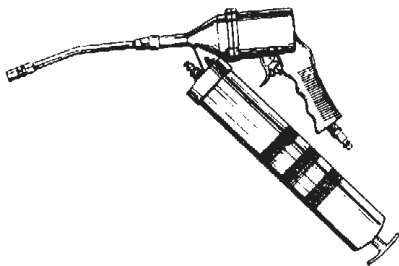

**Air-Powered Grease Gun**  
(Lincoln model 1160)

**6" Rigid Extension**  
**Hydraulic Coupler** with ball check

The 3092 offers one-hand operation made easy with the squeeze of a trigger. Pistol type air operated with rigid and flexible extensions. 50:1 ratio with air input range of 30-150 psi. All metal construction. Length: 15-1/2". Lube capacity: 14-1/2 oz. cartridge or 16 oz. bulk. *One year limited warranty. "Flip-Over" follower is set for cartridge use.* **Part No. 3092**

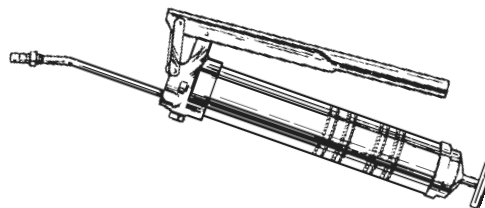

**Heavy Duty Lever Type**  
(Lincoln model 1142)

**Handy Three-Way Loading\*** - by cartridge, suction, or filler pump. Bulk filler plug quickly adapts to bulk fillers

**Rugged Cast Iron Pump Head** adds to durability and provides protection for plunger & check valve.

**Extra Heavy Follower Spring** for positive priming and uninterrupted pumping action.

**6" Rigid Extension**  
**Heavy Duty Hydraulic Coupler** with ball check

The 3090 is the first choice of users everywhere. Gun head, toggle and handle assembly are zinc plated, barrel is finished in high gloss blue poly urethane paint. Length: 21-3/4". Lube capacity: 14-1/2 oz. cartridge or 16 oz. bulk. *One year limited warranty. "Flip-Over" follower is set for cartridge use.* **Part No. 3090**

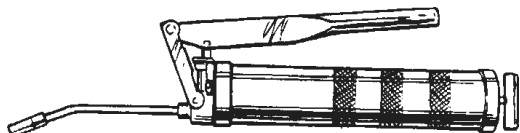

**Economy Lever Type**  
(Lincoln model 1121)

**Handy Three-Way Loading** - by cartridge, suction, or filler pump. Bulk filler plug quickly adapts to bulk fillers

**6" Rigid Extension**  
**Hydraulic Coupler** with ball check  
**One Year Limited Warranty**

The 3089 is a rugged yet economy priced lever action grease gun. All steel construction. Gun head, toggle, handle assembly and barrel finished in high gloss red polyurethane paint. Length: 21-3/4". Lube capacity: 14-1/2 oz. cartridge or 16 oz. bulk. *One year limited warranty. "Flip-Over" follower is set for cartridge use.* **Part No. 3089**

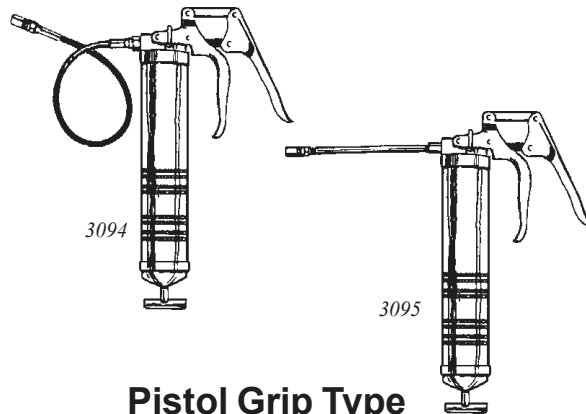

**Pistol Grip Type**  
**Heavy Duty Grease Guns**

Choose the Pistol-Grip for fast, one-handed operation. Similar features of the 3090. Gun head, toggle and handle assembly are zinc plated, barrel is finished in high gloss blue poly urethane paint. Length: 15-1/2". Lube capacity: 14-1/2 oz. cartridge or 16 oz. bulk. *One year limited warranty. "Flip-Over" follower is set for cartridge use.*

Part No.	Description	Lincoln Model
3094	Grease Gun w/18" Hose	1133
3095	Grease Gun w/6" Extension	1132

# Grease Control Valve, Grease

**LINCOLN**

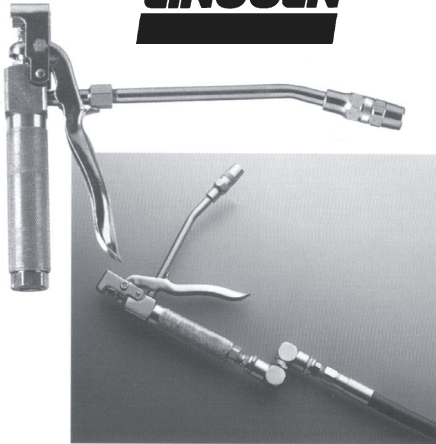

## High Pressure Control Valve

Handy trigger guard prevents pinching. 7,500 psi maximum operating pressure. Precision-machined all steel handle, body and guard. Knurled handle for positive grip. Rigid extension and coupler included. Inlet: 1/4" NPT female. Outlet: 1/8" NPT female. *Lincoln model 740.* Pkg: 1 each. **Part No. 3125**

## High Pressure Universal

1/4" NPT male both ends. For use with lubricants only. Not for corrosive or abrasive materials. *Lincoln model 83594.* Pkg: 1 each. **Part No. 3126**



## Multi-Purpose Lithium Grease

For general purpose industrial and automotive applications. Excellent water resistance, mechanical stability and protection against rust. *NLGI No. 2 density. Color: black.*

Part Number	Size	Pkg Qty
MS-GL-14 .....	Net 14 oz. Cartridge .....	10
PW-30-127 .....	3 oz. Cartridge, 3/pkg .....	1 PKG



## Lubriplate® No. 630-2 High Temperature Grease

The ideal multi-purpose high temperature, extreme pressure, water repellent, protective lubricant. Use for general lubrication of industrial, automotive, marine, construction and farm equipment. *NLGI No. 2 density. Temperature range: 0°F to 350°F. Color: Tan.*

Part Number	Size	Pkg Qty
LP-L0072-098 .....	Net wt. 14.5 oz. Cartridge .....	10

*Permatex Industrial*

**Super Lube®**

Long-lasting, high temperature synthetic grease with Teflon® held in suspension. Lasts 4 times longer than traditional petroleum based grease. Nontoxic, non-flammable and biodegradable. *Temperature range: -65°F to 500°F. USDA category H-1 for use in federally inspected meat and poultry plants. Color: Clear.*

Part Number	Size	Pkg Qty
LT-82328 .....	14.1 oz. Cartridge .....	12



## Super Impact Grease

Withstands the heavy impact and pounding pressure common to heavy equipment. Resists spatter and pounding out through the bearing or fitting. Resistant to high temperatures and water wash-out from pressure washers. *NLGI No. 2.5 density. Temperature range: 0°F to 550°F. Timken load: 65. Color: Green.*

Part Number	Size	Pkg Qty
30-999 .....	Net wt. 14 oz. Cartridge .....	10

# Proof Coil Chain

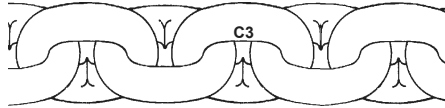

General purpose welded chain for ordinary applications not requiring high strength-to-weight ratios. Uses: tow chains, pipe hanger, guard rail, and logging chains. *Not for lifting.* Elongation minimum 15%. Proof tested. Low carbon steel. Packaged in pails. Zinc finish.

Trade Size	Inside Length	Inside Width	Working Load Limit	Part No.	Pkg Qty
3/16	.95	.40	750	38-308	250'
1/4	1.00	.50	1250	38-309	141'
5/16	1.10	.50	1900	38-310	92'
3/8	1.23	.62	2650	38-311	63'
1/2	1.54	.79	4500	38-312	40'

*\*DO NOT USE FOR OVERHEAD LIFTING.*

*Do not exceed working load limit.*

# High Test Chain

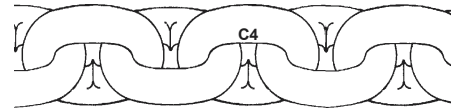

Used for truck load binding, towing, logging and other applications requiring higher strength chain. *Not for lifting.* Elongation minimum 15%. Proof tested. High carbon steel. Self colored finish. Packaged in pails.

Trade Size	Inside Length	Inside Width	Working Load Limit	Part No.	Pkg Qty
1/4	0.79"	0.40"	2,600	38-315	150'
5/16	1.01"	0.48"	3,900	38-316	100'
3/8	1.15"	0.58"	5,400	38-317	75'
1/2	1.43"	0.76"	9,200	38-318	40'

*\*DO NOT USE FOR OVERHEAD LIFTING.*

*Do not exceed working load limit.*

# Machine Chain



Welded twist links are shorter and narrower permitting chain to lie flat. Uses: utility; farm, animal leads, etc. *Not for lifting.* Low carbon steel. Plain finish. Pkg: 100 ft.

Trade Size	Material Size	Inside Length	Inside Width	Working Load Limit*/lb	Part No.
2/0	0.192"	0.730"	0.280"	520	1800

*\*DO NOT USE FOR OVERHEAD LIFTING.*

*Do not exceed working load limit.*

# Alloy Welded Chain

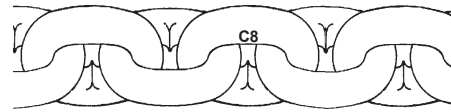

USED FOR OVERHEAD LIFTING and applications demanding a combination of minimum weights and high working load limits. Elongates in excess of the 15% minimum requirement. Proof tested. Alloy steel, heat treated. Shot-peened finish. Packaged in pails.

Trade Size	Inside Length	Inside Width	Working Load Limit	Part No.	Pkg Qty
7/32	.69	.30	2,500	38-320	150'
9/32	.86	.45	4,100	38-321	150'
3/8	1.10	.55	7,300	38-322	75'
1/2	1.55	.72	13,000	38-323	40'

*\*Do not exceed working load limit*

# Coil Chain



This long-linked utility chain is less likely to kink. *Not for lifting.* Low carbon steel. Pkg: 100 ft.

Trade Size	Material Size	Inside Length	Inside Width	Working Load Limit*/lb	Part No.
2/0	0.192"	1.260"	0.340"	520	1813

*\*DO NOT USE FOR OVERHEAD LIFTING.*

*Do not exceed working load limit.*

## Our Freight Policy for Chain

*Our standard freight allowance does not apply. Freight will only be paid if your chain order is accompanied by a \$300 order in packaged merchandise.*

*Note: Any chain that is cut-to-order is not returnable.*





## Single Loop Chain

("Lock Link" Chain)

Uses: Ideal for sprocket wheel or valve wheel chains, overhead door chains, ventilator chains and machinery chains. Low carbon steel. Zinc finish.  
Pkg. Qty. - 100 ft.

Trade Size	Material Diameter	Inside Length	Working Load Limit*/lb	Part No.
2	.091	1.08	155	5800
1/0	.120	1.29	265	5801
2/0	.135	1.48	340	5802
3/0	.148	1.63	405	5803
4/0	.162	1.80	485	5804



**Do not use for overhead lifting.**  
\*Warning: Do not exceed working load limit

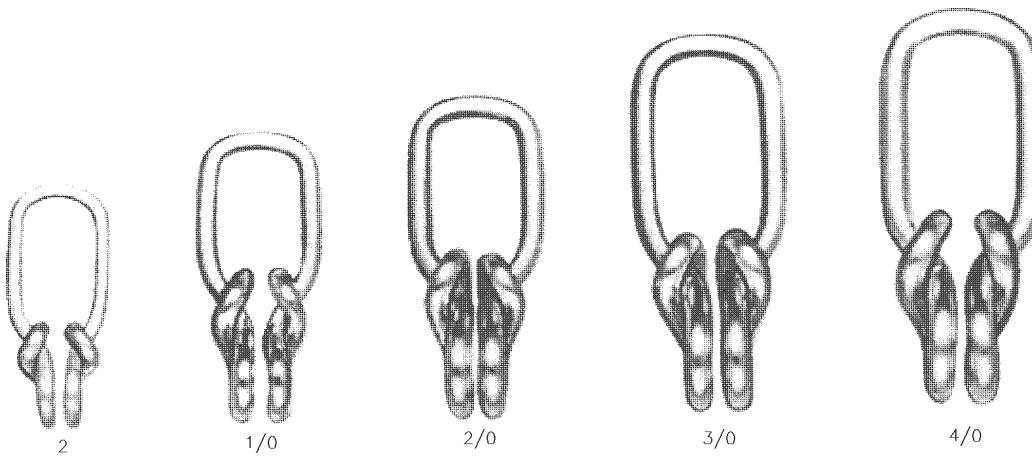

(Actual Size)



## Double Loop Chain

Uses: playground and gymnasium equipment, farm, and animal chains, fixture, swing suspension chains, boat chains, gate chains. Low carbon steel. Zinc finish.  
Pkg. Qty. - 100 ft.

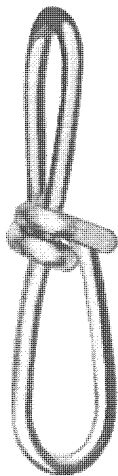

(Actual Size)

Trade Size	Material Diameter	Inside Length	Working Load Limit*/lb	Part No.
2/0	.135	2.17	255	5808



**Do not use for overhead lifting.**  
\*Warning: Do not exceed working load limit

## Load Binders

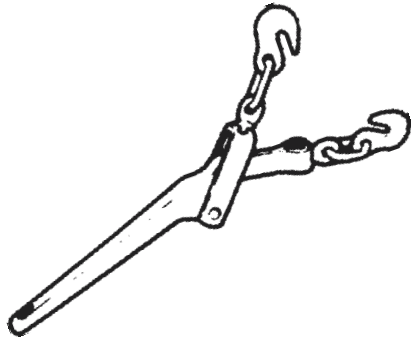

Lever type for Transport (System 7) or High Test (System 4) Chain.

Part No.	Transport Chain Size	High Test Chain Size	Working Load Limit*	Take Up
10-381	-	1/4	2600#	2-3/4"
10-380	5/16	3/8	5400#	4-1/2"

\*Warning: never use above working load limits.

## Utility Chain Tightener

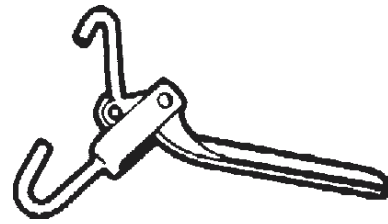

Steel handle and formed swivel J-hooks for tying down equipment. Tie-down equipment and bind light loads. Use with 3/16" proof coil chain (System 3). Use at least 1 strap for every 375 lbs. of load. Made in U.S.A.

Part No.	Size	W.L.L.*	Take Up
10-384	3/16"	375#	3"

\*Warning: never use above working load limits.

## Rope Ratchet™



### Compact Ratchet Tie-Down System

Tie-down loads and tarps. Secure aircraft and boats. Straighten wind-blown trees or hang game. Attach two hooks supplied and pull the loose end of rope tight. Rope Ratchet may be pulled as tightly as needed. Once pulled, it stays put. Release tension by taking up slack and pushing the convenient thumb release lever. 8 feet of solid braid rope included. Made in U.S.A.



Part No.	Load Limit	Description	Pkg Qty
10-745	150 LBS	1/4" Rope (2-Pack)	1 Pkg
10-746	150 LBS	1/4" Rope (6-Pack)	1 Pkg
10-747	250 LBS	3/8" Rope (1-Pack)	1 Pkg
10-748	250 LBS	3/8" Rope (6-Pack)	1 Pkg

## Ratchet Straps

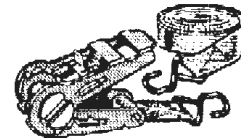

### LIGHT DUTY STRAP W/ S-HOOKS

1" WIDE for small loads. S-hooks are heat-treated and vinyl coated. 1" wide webbing X 15 ft. Working load limit: 400 pounds. Use at least 1 strap for every 400 lbs. of load. Breaking strength: 1,200 pounds. Size: 1" x 15" Made in U.S.A. Pkg: 1 each. Part no. 10-720B

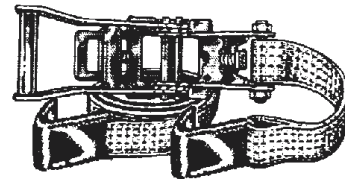

### HEAVY DUTY STRAP W/ FLAT HOOKS

Designed to handle most types of flatbed tie-down requirements. Extra long & wide handle. Meets CVSA guidelines. Made in U.S.A.

**2" WIDE WEBBING** Overall length: 27ft. Fixed end length: 18". Working load limit: 3,335 lbs. Breaking strength: 10,000 lbs. D.O.T. requirement: 1 strap for every 3,335 lbs. of load. Pkg: 1 each. Part No. 10-713

**3" WIDE WEBBING** Overall length: 27ft. Fixed end length: 18". Working load limit: 5,000 lbs. Breaking strength: 15,000 lbs. 5,000 lb. working load limit, 15,000 lb. breaking strength. D.O.T. requirement: 1 strap for every 5,000 lbs. of load.

Pkg: 1 each. Part No. 10-712



# Wire Rope

(Aircraft Cable)



Cross Section  
Flexible 7 x 7



Cross Section  
Extra Flexible 7 x 19

Galvanized cable in 7 x 7 or extra flexible 7 x 19 construction, as illustrated. It is high-strength, aircraft quality. Vinyl coated is more resistant to abrasion and weathering; it can also be cleaned easily. A quality import.

Size	Type	Safe Working Load Limit <sup>1</sup> /lb	Part No.	Feet /Reel
<b>UNCOATED</b>				
1/16	7 x 7	96	5834	500
3/32	7 x 7	184	5835	500
1/8	7 x 19	340	5836	500
3/16	7 x 19	840	5837	250
1/4	7 x 19	1400	5838	250
3/8	7 x 19	2880	5839	100 <sup>2</sup>
<b>VINYL COATED</b> Size does not include vinyl coating.				
3/32	7 x 7	184	5830	250
1/8	7 x 7	340	5831	250
3/16	7 x 19	840	5832	250
1/4	7 x 7	1400	5833	200

<sup>1</sup>Warning: Do not exceed safe working load limit.

<sup>2</sup>Bulk packaged, not shipped on reel.

Note: Operating wire ropes should be lubricated well.

## ATTACHING WIRE ROPE CLIPS



THERE IS ONLY ONE CORRECT METHOD FOR ATTACHING WIRE ROPE CLIPS TO CABLE. A.) THE BASE OF THE CLIP BEARS ON THE LIVE END OF THE ROPE. B.) THE U-BOLT BEARS ON THE DEAD END OF THE ROPE. INSTALL AS FOLLOWS;

1. Snuggly attach first clip with U-Bolt against "dead-end" (not the load-bearing end) - do not fully tighten.
2. Attach second clip in same manner- at base of thimble.
3. Attach all other clips in the same manner, if required. Note: if a greater number of clips are used than shown on the table below, rope turnback should be increased proportionately.
4. With rope under tension, the nuts should be tightened equally and retightened again after first period of use.

CABLE SIZE	MINIMUM NO. CLIPS	TURN-BACK CABLE LENGTH	TORQUE LBS. FT.*
1/16-1/8	2	3.25"	4.5
3/16	2	3.75"	7.5
1/4	2	4.75"	15
5/16	2	5.25"	30
3/8	2	6.50"	45

\*Estimated torque for drop forged style wire rope clips.

# Wire Rope Clips

(Cable Clamps)

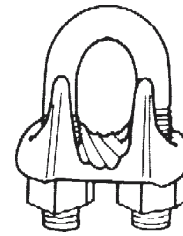

## Malleable Wire Rope Clips

Standard clip for light duty applications.

Part No.	Cable Size	Pkg Qty
1684	1/16	25
1685	1/8	25
1686	3/16	25
1687	1/4	10
1688	5/16	10
1689	3/8	10
1691	1/2	10
1693	5/8	10
1694	3/4	10
1695	7/8	5
1696	1"	5

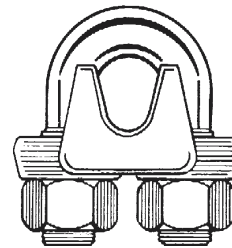

## Drop Forged Wire Rope Clips

Drop forged steel for heavy duty applications.

Part No.	Cable Size	Pkg Qty
1985	1/8	10
1986	3/16	10
1987	1/4	10
1988	5/16	10
1989	3/8	10
1991	1/2	10
1993	5/8	10
1994	3/4	10
1995	7/8	5
1996	1"	5
1998	1-1/4	2



## Aluminum Cable Ferrules

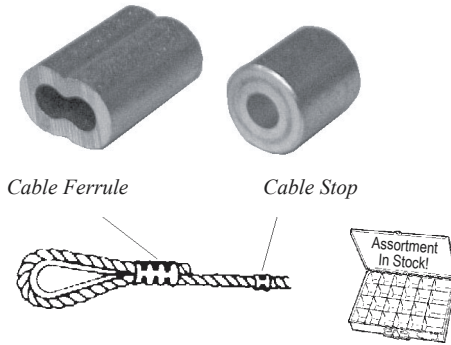

### Aluminum Ferrules

Part No.	Size	Pkg
10-538	1/16"	50
10-539	3/32"	50
10-540	1/8"	50
10-541	5/32"	50
10-542	3/16"	50
10-543	1/4"	50

### Aluminum Stops

Part No.	Size	Pkg
10-544	1/16"	50
10-545	3/32"	50
10-546	1/8"	50
10-547	5/32"	50
10-548	3/16"	50
10-549	1/4"	50

## Wire Rope Swaging Tool



This powerful tool crimps ferrule and stops in sizes 1/16, 3/32, 1/8, 5/32 and 3/16". Overall length: 25". **Part No. 10-396**

## Wire Rope Thimbles



Cable Size	Regular Duty (Zinc)	Heavy Duty (Galv)	Pkg Qty
1/8	1700	-	10
3/16	1701	-	10
1/4	1702	2002	10
5/16	1703	2003	10
3/8	1704	2004	10
1/2	1705	2005	10



## Wire Rope Cutter

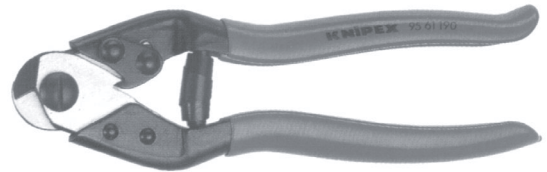

Cuts steel and stainless steel wire rope, aircraft cable, copper and aluminum wire, and small iron rod. Sharp hardened (60 HRC) precision ground cutting edges are factory tested. Angular blades designed for clean cutting of wire, ropes, and steel cables without crushing or fraying ends. Material: special tool steel, oil-hardened. Ergonomic design. Overall length: 7 1/2". Plastic coated handles. Made in Germany. *Cutting capacity: wire and cable to 1/4", steel rod to 3/16". Limited lifetime warranty.* **Part No. 10-395**

VISIT OUR WEBSITE  
**mpi-online.com**  
 FAX ANYTIME!  
**219-696-6413**

# Safety Swivel Hooks

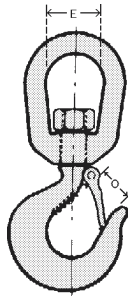

Drop Forged. Hot galvanized. Pkg. 1 each

Part No.	Throat Opening (O)	Eye I.D. (E)	W.L.L.*
7-112	7/8	1-1/4	3/4 ton
7-113	31/32	1-1/2	1 ton

# Safety Hooks

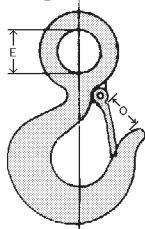

Drop Forged. Hot galvanized. Pkg. 1 each

Part No.	Trade Size	Throat Opening(O)	Eye I.D.(E)	W.L.L.*
7-114	1/4	3/4	1/2	1/2 ton
7-115	5/16	1"	3/4	1 ton
7-116	3/8	1-1/4	7/16	2-1/2 ton

*\*WARNING: do not exceed working load limit*

# Twisted Fiber Rope

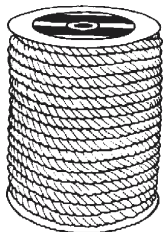

**TWISTED POLYPROPYLENE ROPE** is lightweight and resistant to rot and some chemicals. Nearly twice as strong as manila rope. Uses: tying line, loads, pulling larger rope or wire cable. Color: yellow. Pkg: 1 Roll

**MANILA ROPE** is easy to handle and resistant to internal and external wear. Color: brown. Pkg: 1 Roll

Part No.	Roll Size	Type	WLL /LBS
17-136	1/4 x 50'	Polypropylene	125
17-137	3/8 x 50'	Polypropylene	270
17-138	1/2 x 50'	Polypropylene	467
17-139	1/4 x 100'	Manila	54
17-140	3/8 x 50'	Manila	122
17-141	1/2 x 50'	Manila	264

*Strength based on 10% to 12% of new rope breaking strength.*

# Swivels



## Eye to Eye

Part No.	Trade Size	Eye I.D.	W.L.L. /Lb*.
7-100	1/4	3/4	850
7-101	5/16	1"	1,250
7-102	3/8	1-1/4	2,250
7-103	1/2	1-1/2	3,600
7-104	5/8	1-3/4	5,200
7-105	3/4	2"	7,200

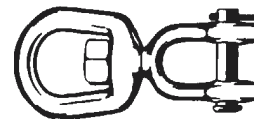

## Eye to Jaw

Part No.	Trade Size	Eye I.D.	W.L.L. /Lb.*
7-106	1/4	3/4	850
7-107	5/16	1"	1,250
7-108	3/8	1-1/4	2,250
7-109	1/2	1-1/2	3,600
7-110	5/8	1-3/4	5,200
7-111	3/4	2"	7,200

*\*WARNING: do not exceed working load limit*

# Safety Hook Latch Repair Kits

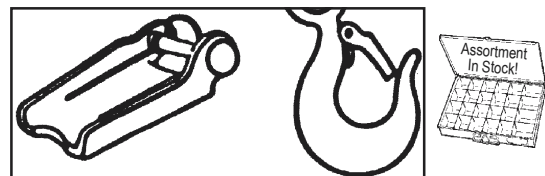

Drop Forged. Hot galvanized. Pkg. 1 each

Part No.	Hook Size		Hook Opening**
	Trade #	Tons	
5840	2, 22	3/4	29/32"
5841	3, 23	1	31/32"
5842	4, 24	1 1/2	1-1/32"
5843	5, 25	2	1-1/8"
5844	6, 26	2 1/2	1-7/32"
5845	7, 27	3	1-5/16"
5846	8, 28	4	1-1/2"
5847	9, 29	5	1-21/32"
5848	10, 30	6	1-7/8"
5849	11, 31	7	2"
5850	12, 32	10	2-5/16"
5852	34	15	3-5/32"

*\*\*Hook opening size is with latch installed.*

# Aluminum Turnbuckles



Eye & Eye

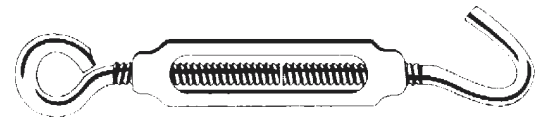

Hook & Eye

Aluminum body. Zinc finished steel eyebolts & hooks.

Eye & Eye	Hook & Eye	O.A. L. Closed	O.A. L. Open	Take Up	Body O.A. Length	Thread Diameter	Pkg Qty
5777	5783	3-1/4	4-1/2	1-1/4	1-3/4	5/32	10
5778	5784	4"	5-5/8	1-5/8	2-1/8	3/16	10
5779	5785	4-3/4	6-5/8	1-7/8	2-1/2	7/32	10
5780	5786	5-1/4	7-3/8	2-1/8	2-7/8	1/4	10
5781	5787	6-1/2	9-1/8	2-5/8	3-1/2	5/16	10
5782	5788	7-3/4	10-3/4	3"	4-1/8	3/8	10

## Drop Forged Steel Turnbuckles



Eye & Eye  
C-1035 high carbon steel  
Self-colored finish • Pkg. 1 each

Part No.	Size	Take Up
5735	3/8-16	6"
5736	1/2-13	6"
5737	1/2-13	9"
5738	1/2-13	12"
5739	5/8-11	6"
5740	5/8-11	12"
5741	3/4-10	6"
5742	3/4-10	9"
5743	3/4-10	12"

\*Note: galvanized available upon special request



## Master® Laminated Pad Locks

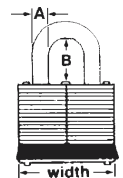

Note: Keyed-alike locks sold only in packages of six.

Part No.	Tumbler Keyed	Pkg Qty	SHACKLE		
			A	B	Width
<b>Light Duty - (Master 3D, 3KA)</b>					
10-604	Different	1	9/32	3/4	1-1/2
10-605	Alike	6	9/32	3/4	1-1/2
<b>Medium Duty - (Master 1D, 1KA)</b>					
10-602	Different	1	5/16	15/16	1-3/4
10-603	Alike	6	5/16	15/16	1-3/4
<b>Heavy Duty - (Master 17D, 17KA)</b>					
10-600	Different	1	7/16	1"	2"
10-601	Alike	6	7/16	1"	2"
<b>Extra Heavy Duty - (Master 15D, 15KA)</b>					
10-598	Different	1	7/16	1"	2-1/2
10-599	Alike	6	7/16	1"	2-1/2



# High-Test Chain Hooks

Drop forged & heat treated. Use with Proof Coil or High Test chain. Self-colored finish. *Not recommended for overhead use.*

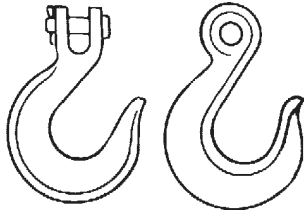

## High-Test Slip Hooks



Trade Size	Working Load	Part Number		Pkg Qty
	Limit*/lb	Clevis Type	Eye Type	
1/4	2,600	1748	1762	5
5/16	3,900	1749	1763	5
3/8	5,400	1750	1764	5
7/16	7,200	1751	1765	5
1/2	9,200	1752	1766	5

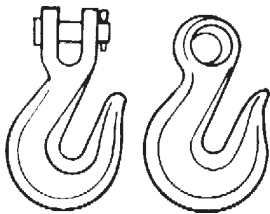

## High-Test Grab Hooks



Trade Size	Working Load	Part Number		Pkg Qty
	Limit*/lb	Clevis Type	Eye Type	
1/4	2,600	1741A	1755	5
5/16	3,900	1742	1756	5
3/8	5,400	1743	1757	5
7/16	7,200	1744	1758	5
1/2	9,200	1745	1759	5
5/8	11,500	1746	1760	1

# Alloy Chain Hooks

Forged from alloy steel. Heat treated. Self-colored finish. Rated for overhead use.

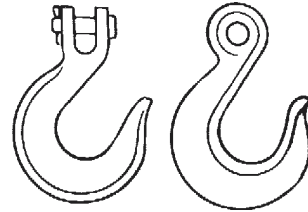

## Alloy Slip Hooks

Trade Size	Working Load	Part Number		Pkg Qty
	Limit*/lb	Clevis Type	Eye Type	
1/4	3,250	5661	1898	5
5/16	5,000	5662	5669	5
3/8	6,600	5663	1898A	5
7/16	8,750	5664	5670	5
1/2	11,250	5665	1899	5
5/8	16,500	5666	-	1

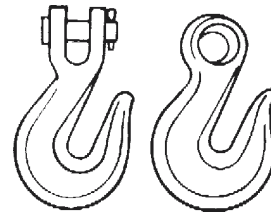

## Alloy Grab Hooks

Trade Size	Working Load	Part Number		Pkg Qty
	Limit*/lb	Clevis Type	Eye Type	
1/4	3,250	5655	1890	5
5/16	5,000	5656	5667	5
3/8	6,600	5657	1891	5
7/16	8,750	5658	5668	5
1/2	11,250	5659	1892	5
5/8	16,500	5660	1893	1

*\*WARNING: do not exceed working load limit*

**SAVE TIME BY LETTING US LOCATE  
THOSE HARD-TO-FIND ITEMS FOR YOU!**

# Connecting Links

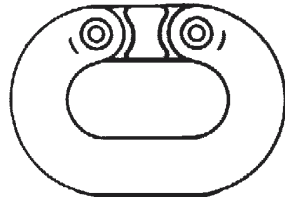

The standard link for temporary or permanent chain repairs or coupling attachments. For use with proof coil chain only. Drop forged & heat treated. Self-colored finish.

Part No.	Trade Size	W.L.L.*	Pkg
1712	3/16	800	10
1713	1/4	1,400	10
1714	5/16	2,000	10
1715	3/8	2,800	10
1716	7/16	3,625	10
1717	1/2	4,750	10
1718	5/8	7,250	5
1719	3/4	10,250	5

# Cold Shuts

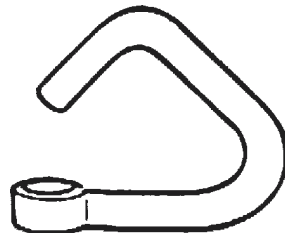

An inexpensive method of repairing or connecting chains quickly. Use next size larger than chain size for additional safety factor. For use with proof coil chain only. May be welded closed. Plain finish.

Part No.	Trade Size	W.L.L.*	Pkg
1723	3/16	750	25
1724	1/4	1250	25
1725	5/16	1900	25
1726	3/8	2650	25
1727	7/16	3500	10
1728	1/2	4500	10
1729	5/8	6900	10
1730	3/4	9750	10



# Repair Links

(Lap links)



For chain repair and coupling of attachments. Low carbon steel. May be welded closed. Plain finish.

Part No.	Trade Size	W.L.L.*	Pkg
1731	3/16 x 1	240	25
1732	7/32 x 1-1/4	250	25
1733	1/4 x 1-1/4	400	25
1736	1/4 x 2	400	25
1734	9/32 x 1-1/4	525	25
1737	5/16 x 1-1/2	950	25
1738	5/16 x 2	1000	25
1739	3/8 x 1-5/8	1250	25
1740	3/8 x 2	1250	25
1741	1/2 x 2-1/2	2125	10
1754	5/8 x 2-1/2	1000	5

# Quick Links

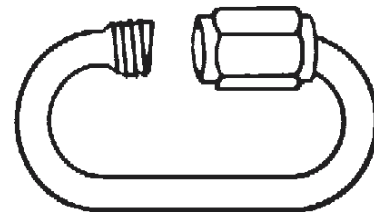

Fast easy connections for permanent or temporary applications with low carbon chain. Should be tightened with a wrench. Zinc finish.

Part No.	Trade Size	W.L.L.*	Pkg
5684	1/8	220	10
5685	3/16	660	10
5686	1/4	880	10
5687	5/16	1760	10
5688	3/8	2220	10
5689	1/2	3300	5

\*Safe Working Load Limit - Lbs.



## Bent Pull Pins

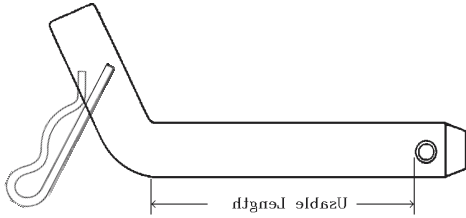

**WITH HAIRPIN COTTER**



A low cost pin with handle and pin bent in a one piece configuration. Commonly found on trailer hitch receivers. Machined from AISI 1018 - 12L14 carbon steel\*. Zinc finish.

Part Number	Diameter	Usable Length	Pkg Qty
7-2123	1/2"	3"	5
7-2124	5/8"	3"	5

*\*Also available: 1045 or 1144 high strength alloy steel, subject to minimum order.*

## "Big-Orange" Forged Hitch Pins

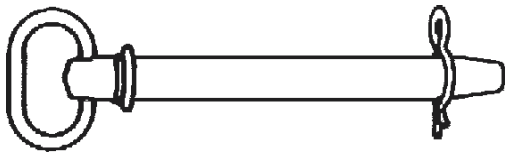

Drop-forged steel. D-Ring type handle swivels freely. Orange enamel finish. Hairpin Cotter provided. Pkg. 1 each

Part No.	Diameter	Usable Length
5789	7/16	3-1/2
5790	1/2	3-1/2
5791	5/8	3-3/4
5792	5/8	6"
5793	3/4	4"
5794	3/4	6-1/4
5795	7/8	4-1/4
5796	7/8	6-1/2
5797	1"	4-3/4
5798	1"	6-3/4
5799	1-1/8	7"
5809	1-1/4	7"

## D-Ring Hitch Pins

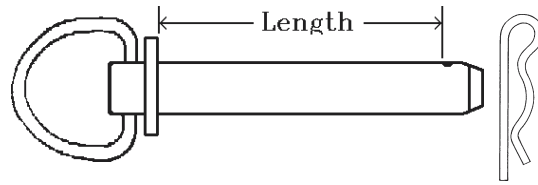

Machined 1035 steel. D-Ring type handle swivels freely to stay out of the way. Hairpin cotter provided. Zinc finish. Pkg. 1 each

Part No.	Diameter	Usable Length
5693	1/2	3-1/2
5694	5/8	4-1/2
5695	5/8	6"
5696	3/4	4-1/2
5697	3/4	6"
5698	7/8	4-1/2
5699	7/8	6"
5700	1"	4-1/2
5701	1"	6"
5702	1-1/8	7"
5703	1-1/4	7"

## Welded Grip Pins

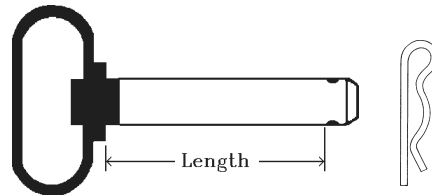

Precision machined steel. Large one-piece handle is welded on and vinyl coated for positive grip. Zinc finish. Hairpin cotter provided. Pkg. 1 each

Part No.	Diameter	Usable Length
5810	1/2	4"
5811	5/8	4-1/2
5812	5/8	6"
5813	3/4	4-1/2
5814	3/4	6-1/2
5815	7/8	4-1/2
5816	7/8	6-1/2
5817	1"	4-1/2
5818	1"	6-1/2
5819	1-1/8	7"
5820	1-1/4	7"

## Safety Pins

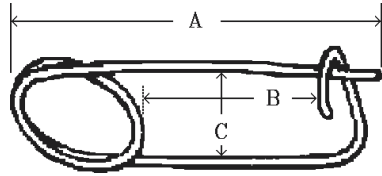

Positive locking pin for retaining clevis pins. Made from hard-drawn plated spring wire. Pkg. 10 each

Part No.	O.A. Length (A)	Inside (B)	Width (C)	Wire Dia.
7-2120	2-3/4"	1-11/16"	5/8"	.091"
7-2121	4-3/8"	2-13/16"	13/16"	.120"
7-2122	5-3/4"	3-3/4"	1-1/8"	.148"

## Snap Lock Pins

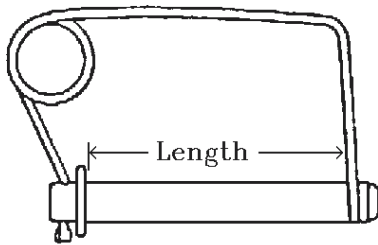

Tempered spring-steel snap stays locked. One-piece component. Zinc plated steel. Pkg. 1 each

Part No.	Diameter	Usable Length
5744	1/2"	3-1/2"
5745	5/8"	4"
5746	3/4"	4"
5747	3/4"	6"
5748	7/8"	5-1/2"
5749	1"	5-1/2"

## NEW LOCKING COTTERS!



SEE PAGE 129.

## Clevises

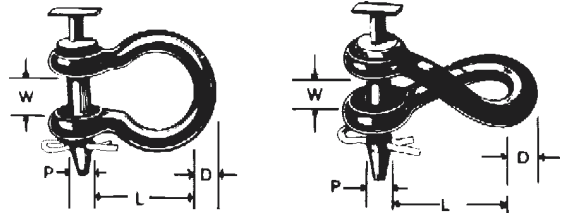

Painted - with zinc plated, heat treated pins and cotters. For farm use only. Pkg. 1 each

Part No.	Type	P Pin Size	D Body Size	W Between Eyes	L Usable Length	WLL* (lbs)
5711	Straight	5/8	3/4	1-5/16	3-3/4	12,000
5716	Twist	5/8	3/4	1-5/16	3-1/2	12,000
5712	Straight	3/4	7/8	1-5/16	3-1/4	16,000
5717	Twist	3/4	7/8	1-5/16	3"	16,000
5718	Twist	3/4	7/8	1-5/16	3-7/8	16,000
5714	Straight	7/8	15/16	1-3/8	4-5/8	20,000
5715	Straight	1"	1"	2-1/8	5-5/16	25,000
5720	Twist	1"	1"	2-1/8	5"	25,000

*\*Warning: do not exceed working load limit. Not to be used for lifting.*

## Tee Handle Clevis Pins

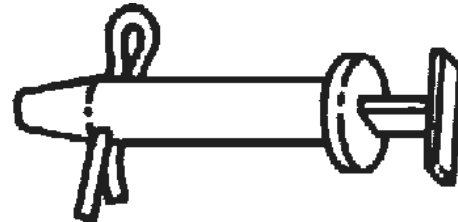

For use with Clevises shown above. Pkg. 1 each

Part No.	Diameter	Usable Length
5704	5/8"	3-1/8"
5705	3/4"	3-1/4"
5706	7/8"	3-3/4"
5707	1"	4-1/2"



# Wire Lock Pins

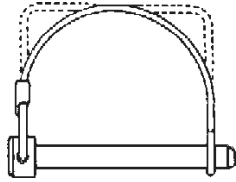

1010 steel pin, spring steel wire. Zinc finish.

Part No.	Wire		Usable Length	Pkg Qty
	Loop Shape	Pin Diameter		
5729	Round	1/4	1-3/4	5
5730	Round	3/8	1-1/2	5
5731	Square	5/16	2-1/2	5
5732	Square	3/8	2-1/4	5

# Lynch Pins

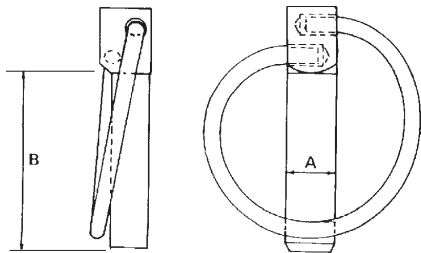

1010 carbon steel. Zinc Dichromate finish.

Part No.	Diameter (A)	Usable Length (B)	Pkg Qty
5722	3/16	1-9/16	10
5723•	3/16	1-9/16	10
5724	1/4	1-3/4	10
5725•	1/4	1-3/4	10
5726	5/16	1-3/4	10
5727	7/16	1-3/4	10
5728	7/16	1-15/16	10

• With chain & cotter pin attached.

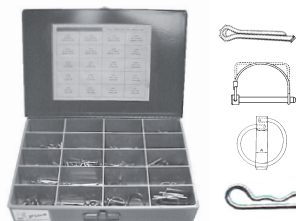

**VARIETY PIN ASSORTMENT**  
20 SIZES, WIRE LOCK PINS, LYNCH PINS, COTTER PINS, & HAIRPIN COTTERS, IN A LARGE STEEL DRAWER.  
**PART NO. 16-0320**

# Bolt Snaps



## Swivel Eye Bolt Snap

Part No.	A	B	C
5751	1/2	3-1/8	3/8
5752	5/8	3-1/4	3/8
5754	7/8	3-1/2	3/8

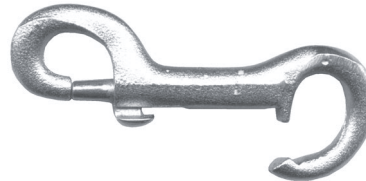

## Open End Bolt Snap

If metal is cold, heat with match or lighter, then tap lightly to shut. *Do not attempt to close by squeezing.*

Part No.	A	B	C
5757	1/4	2-3/8	7/32
5758	3/8	3-1/8	3/8
5759	1/5	4"	3/8
5760	5/8	6"	1/2



## Double End Bolt Snap

Part No.	B	C
5761	3-3/8	1/4
5762	4"	3/8
5763	4-3/4	3/8

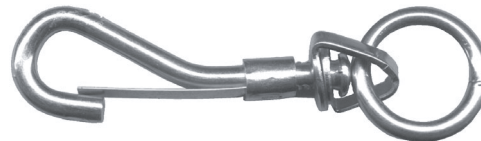

## Swivel Rope Snap

Part No.	A	B	C
5772	1"	4-1/8	1/4

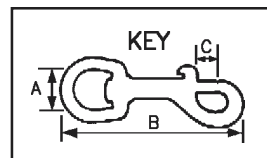

*\*All snaps supplied with zinc or nickle plated - stainless steel springs.*



## Double Clevis Links

(Mid-Links)

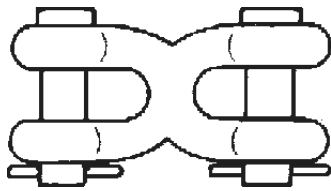

Forged, heat treated and tempered for permanent or temporary use to connect high-test and proof coil chain. Zinc finish. *Not for overhead lifting.* **Truckers: On-The-Job repairs possible for your tie-down chains. Handy in the tool box to lengthen chains for special jobs.**

Part No.	Size	W.L.L.*/lb	Pkg Qty
5680	1/4 or 5/16	3900	5
5681	3/8	5400	5
5682	7/16 or 1/2	9200	2

*Warning: Not to be used for lifting.*

## Alloy Coupling Links

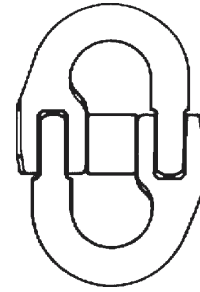

*Approved for overhead use.* Used in field for assembling chain slings. Links have rotating load pins that resist bending and offer shear values in excess of the chain. Can be disassembled by driving locking pin out with a hammer. Plain finish. Pkg. 1 each.

Part No.	Trade Size	W.L.L.* (Lbs.)
1881	7/32	2,500
1882	9/32	4,100
1883	3/8	7,300
1884	1/2	13,000
1885	5/8	20,300
1886	3/4	29,300

## Anchor Shackles

Drop forged, heat treated and tempered. Alloy pins are used in all shackles for extra strength. All shackles are marked with size and working load limits in tons. *Not for overhead lifting.* Plain finish. Pkg. 1 each

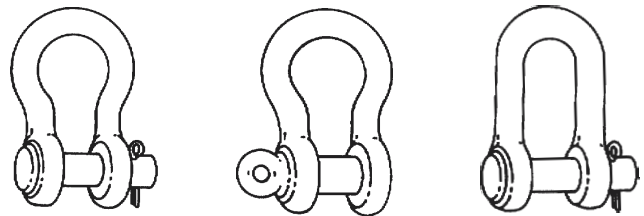

Nominal Shackle Dia.	Pin Dia.	Width Between Eyes	W.L.L.* Tons	PART NUMBER		
				Round Pin	Screw Pin	Round Pin
1/4	5/16	1/2	1/2	2050	2063	2076
5/16	3/8	17/32	3/4	2051	2064	2077
3/8	7/16	21/32	1	2052	2065	2078
7/16	1/2	23/32	1-1/2	2053	2066	2079
1/2	5/8	13/16	2	2054	2067	2080
5/8	3/4	1-1/16	3-1/4	2055	2068	2081
3/4	7/8	1-1/4	4-3/4	2056	2069	2082
7/8	1"	1-7/16	6-1/2	2057	2070	2083
1"	1-1/8	1-11/16	8-1/2	2058	2071	2084

*\*Safe Working Load Limit.*

**WARNING: Do not exceed working load limits.**



# Roller Chain

(Sprocket Chain)

Hardened steel with solid rollers. Choose from riveted or cottered type.  
One connecting link included on each roll. Imported. Pkg: 1 ROLL (10 feet per roll)

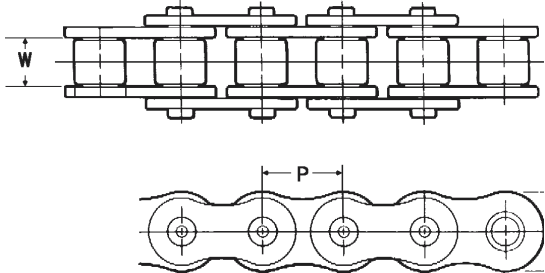

## Single Strand Chain

Hardened Steel • ANSI Standard Series

ANSI No.	Pitch (P)	Width (W)	PART NUMBER	
			Riveted	Cottered
35	3/8	3/16	12-361	-
40	1/2	5/16	12-362	-
41	1/2	1/4	12-363	-
50	5/8	3/8	12-364	-
60	3/4	1/2	12-365	12-400
80	1"	5/8	12-366	12-401
100	1-1/4	3/4	12-367	12-402
120	1-1/2	1"	12-390	12-403
140	1-3/4	1"	12-391	12-404
160	2"	1-1/4	12-392	12-405
200	2-1/2	1-1/2	-	12-406

## 304 Series Stainless Steel

Single Strand Chain

MFR.* No.	Pitch (P)	Width (W)	PART NUMBER	
			Riveted	Cottered
40SS	1/2	5/16	12-497	-
50SS	5/8	3/8	12-498	-
60SS	3/4	1/2	12-499	-

\*Trade reference number - not ANSI number

## ANSI Heavy Series

Hardened Steel • Heavy Duty Single Strand Chain

ANSI No.	Pitch (P)	Width (W)	PART NUMBER
			Riveted
60-H	3/4	1/2	12-394
80-H	1"	5/8	12-395

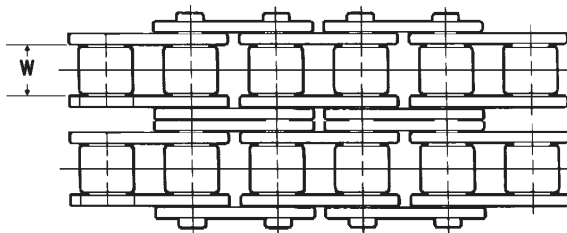

## Double Strand Chain

Hardened Steel • ANSI Standard Series

ANSI No.	Pitch (P)	Width (W)	PART NUMBER	
			Riveted	Cottered
35-2	3/8	3/16	12-409	-
40-2	1/2	5/16	12-410	-
50-2	5/8	3/8	12-411	-
60-2	3/4	1/2	12-412	12-420
80-2	1"	5/8	-	12-421
100-2	1-1/4	3/4	-	12-422
120-2	1-1/2	1"	-	12-423
140-2	1-3/4	1"	-	12-424
160-2	2"	1-1/4	-	12-425
200-2	2-1/2	1-1/2	-	12-426

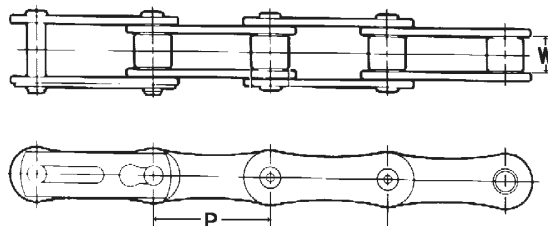

## Drive Type Chain

(Double Pitch, Extended Pitch)

Hardened Steel

ANSI No.	Pitch (P)	Width (W)	PART NUMBER	
			Riveted	Cottered
A-2040	1"	5/16	12-396	-
A-2050	1-1/4	3/8	12-397	-
A-2060	1-1/2	1/2	12-398	-

# Roller Chain Links

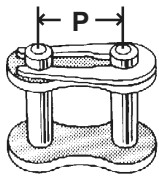

Spring Clip

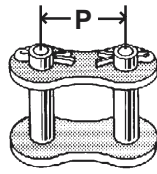

Cottered

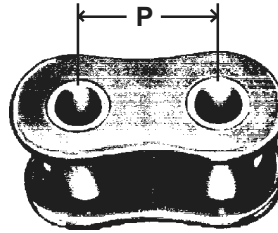

Roller Links

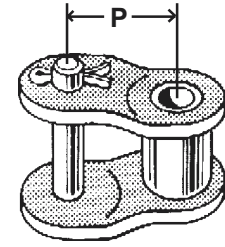

Offset Links

## Connecting Links

(Master Links)

Consists of 3 component parts. One link plate with pins, one detachable link plate that is slip fitted to the pins and either a spring clip or two cotter pins to retain the assembly. Hardened steel.

A one-piece assembly used to lengthen or repair roller chain. Hardened steel.

Used to adjust lengths of chain. Hardened steel.

ANSI No.	Pitch "P"	CONNECTING LINKS		ROLLER LINKS	OFFSET LINKS		Pkg Qty
		Spring Clip	Cottered		Cottered		
35	3/8	12-368	-	12-506	12-379	10	
40	1/2	12-369	-	12-507	12-380	10	
41	1/2	12-370	-	12-508	12-381	10	
50	5/8	12-371	-	12-509	12-382	10	
60	3/4	12-372	-	12-510	12-383	10	
80	1"	12-373	12-474	12-511	12-384	5	
100	1-1/4	-	12-475	12-512	12-385	5	
120	1-1/2	-	12-476	12-513	12-447	5	
140	1-3/4	-	12-477	-	12-448	1	
160	2"	-	12-478	-	12-449	1	
200	2-1/2	-	12-479	-	12-450	1	
35-2	3/8	-	12-480	-	12-451	10	
40-2	1/2	12-481	-	-	12-452	10	
50-2	5/8	12-435	12-482	-	12-453	10	
60-2	3/4	12-436	12-483	-	12-454	10	
80-2	1"	-	12-484	-	12-455	5	
100-2	1-1/4	-	12-485	-	12-456	5	
120-2	1-1/2	-	12-486	-	12-457	5	
140-2	1-3/4	-	12-487	-	12-458	1	
160-2	2"	-	12-488	-	12-459	1	
200-2	2-1/2	-	12-489	-	12-460	1	
60-H	3/4	12-443	12-490	-	12-461	10	
80-H	1"	12-444	12-491	-	12-462	5	
A-2040	1"	12-375	-	-	12-465	10	
A-2050	1-1/4	12-376	-	-	12-466	10	
A-2060	1-1/2	12-377	12-496	-	12-467	10	

## 304 Series Stainless Steel

40SS*	1/2	12-500	-	-	12-503	10
50SS*	5/8	12-501	-	-	12-504	10
60SS*	3/4	12-502	-	-	12-505	10

\*Trade reference number - not ANSI number

Note: Use no more than two repair links in any length of chain.



# Roller Chain Tools

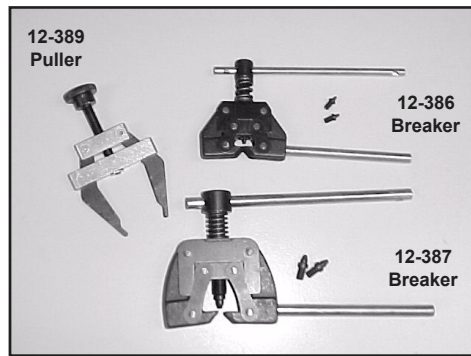

## Roller Chain Breakers

Takes roller chain apart easily without hammers or grinders. All parts are hardened for long life. Tool comes with two replaceable punch points. Import.

Tool Part No.	Replacement Punch Points*	For Chain Size
12-386 .....	12-386RP .....	35 thru 50
12-387 .....	12-387RP .....	60 thru 100

## Roller Chain Puller

Works like a third hand to help you insert and remove connecting links. Allows roller chain to be pulled or released without dropping parts in the dirt or readjusting sprockets. Knurled adjustment screw. Import.

Part No.	Jaw Spread	Chain Size
12-389 .....	2" .....	35 thru 60

*Larger roller chain tools available on request.*



**NOW IN STOCK. See page 327.**



## WORDS OF WISDOM FROM CHILDREN...

1. Never trust a dog to watch your food. - Patrick, age 10
2. When your dad is mad and asks you, "Do I look stupid?" don't answer him. - Michael, 14
3. Never tell your mom her diet's not working. - Michael, 14
4. Stay away from prunes. - Randy, 9
5. Never pee on an electric fence. - Robert, 13
6. Don't squat with your spurs on. - Noronha, 13
7. Don't pull dad's finger when he tells you to. - Emily, 10
8. When your mom is mad at your dad, don't let her brush your hair. - Taylia, 11
9. Never allow your three-year old brother in the same room as your school assignment. - Traci, 14
10. Don't sneeze in front of mom when you 're eating crackers. - Mitchell, 12
11. Puppies still have bad breath even after eating a tic tac. - Andrew, 9
12. Never hold a dust buster and a cat at the same time. -Kyoyo, 9
13. You can't hide a piece of broccoli in a glass of milk. - Armir, 9
14. Don't wear polka-dot underwear under white shorts. - Kellie, 11
15. If you want a kitten, start out by asking for a horse. - Naomi, 15
16. Felt markers are not good to use as lipstick. - Lauren, 9
17. Don't pick on your sister when she's holding a baseball bat. - Joel, 10
18. When you get a bad grade in school, show it to your mom when she's on the phone. - Alyesha, 13
19. Never try to baptize a cat. - Eileen, 8

**Red Hot Deals!**

**Check out our current specials and new items on our website at <http://www.mpi-online.com>**

# Aircraft Type B Jobbers Length Drills



## Type B, Straight Shank Drills High Speed Steel, 135° Split Point

*Meets NAS 907 Type B specifications*

Designed specifically for the aircraft industry. Features the self-centering 135° split point which requires less torque and breaks up chips in deep hole drilling. A heavy duty web geometry provides added rigidity to minimize drill breakage. A special black oxide surface treatment promotes cooler cutting. Use in fixed and portable applications.

### Material Applications

- Medium and high strength steels
- High tensile martensitic stainless steels
- Titanium alloys

*135° split point (1/16-1/2").  
No center-punching required.*



Part No.	Diameter	Flute Length	Overall Length	Pkg Qty
1274•	1/64	3/16	3/4	12
1275•	1/32	1/2	1-3/8	12
1276•	3/64	3/4	1-3/4	12
1277	1/16	7/8	1-7/8	12
1278	5/64	1"	2"	12
1279	3/32	1-1/4	2-1/4	12
1280	7/64	1-1/2	2-5/8	12
1281	1/8	1-5/8	2-3/4	12
1282	9/64	1-3/4	2-7/8	12
1283	5/32	2"	3-1/8	12
1284	11/64	2-1/8	3-1/4	12
1285	3/16	2-5/16	3-1/2	12
1286	13/64	2-7/16	3-5/8	12
1287	7/32	2-1/2	3-3/4	12
1288	15/64	2-5/8	3-7/8	12
1289	1/4	2-3/4	4"	12
1290	17/64	2-7/8	4-1/8	12
1291	9/32	2-15/16	4-1/4	12
1292	19/64	3-1/16	4-3/8	6
1293	5/16	3-3/16	4-1/2	6
1294	21/64	3-5/16	4-5/8	6
1295	11/32	3-7/16	4-3/4	6
1296	23/64	3-1/2	4-7/8	6
1297	3/8	3-5/8	5"	6
1298	25/64	3-3/4	5-1/8	6
1299	13/32	3-7/8	5-1/4	6
1300	27/64	3-15/16	5-3/8	6
1301	7/16	4-1/16	5-1/2	6
1302	29/64	4-3/16	5-5/8	6
1303	15/32	4-5/16	5-3/4	6
1304	31/64	4-3/8	5-7/8	6
1305	1/2	4-1/2	6"	6

• Sizes up to 3/64" have 118° standard point, not split point.

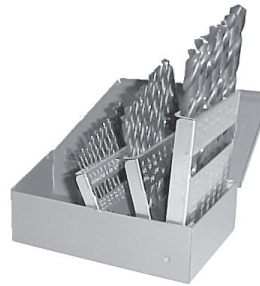

**29 PC. AIRCRAFT DRILL SET**  
1/16 TO 1/2 BY 64THS, STRAIGHT SHANK  
**PART NO. 1496 (INDEX #6003)**

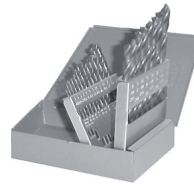

**21 PC. AIRCRAFT DRILL SET (NOT SHOWN)**  
1/16 TO 3/8 BY 64THS, STRAIGHT SHANK  
**PART NO. 5999 (INDEX #5971)**

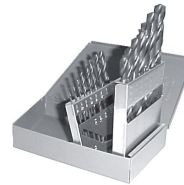

**15 PC. AIRCRAFT DRILL SET**  
1/16 TO 1/2 BY 32THS, STRAIGHT SHANK  
**PART NO. 6006 (INDEX #5970)**

## Cutting Fluid



Nonflammable formula with active sulfur and an extreme pressure additives keeps cutting tools sharper under higher loads when cutting high alloy steels. Clinging foam will not run or overspray. *Not for aluminum cutting.*

Part Number	Size	Pkg Qty
16-0018B	Net wt. 14 oz. Aerosol	12



# Heavy Duty Brute™ Platinum Drills



## Heavy Duty Straight Shank Drills

**M-7 Molybdenum High Speed Steel,  
Special Surface Treatment, 135° Split Point**

*Meets NAS 907 Type J specifications*

Brute Platinum twist drills are engineered for high performance drilling. With an exclusive combination of premium steel, superior geometry, and the unique NOMO® treatment, the Brute reduces drilling cycles and maximizes the number of holes per drill. NOMO® (*Nitride On Margin Only*) a unique nitride surface treatment of the cutting edge which reduces corner breakdown. With NOMO®, nitrogen penetrates the surface of the Brute, increasing hardness without increasing brittleness. The benefit is superior wear resistance and longer tool life. Special M-7 molybdenum high speed steel provides strength and resistance to abrasion and heat. Brute's precision ground self-centering split point bites right in. The split point requires less torque and breaks up chips in deep hole drilling. The Brute features *tapered web geometry*; thin at the point for easy penetration and thick at the base of the flute for added strength. Flutes are oxide and chrome finished to promote cooler drilling. The versatile Brute Drill can be used in applications which require tough, high performance drilling in portable or fixed applications.

### Material Applications

- Martensitic, Austenitic, Precipitation Hardening Stainless Steels • Alloy Steels • Low Alloy and Die Steels
- Titanium Alloys • Aluminum and Magnesium Alloys
- Carbon Steels • Copper and Copper Alloys

*135° split point (1/16-1/2").  
No center-punching required.*



Part No.	Diameter	Flute Length	Overall Length	Pkg Qty
1245	1/16	7/8	1-7/8	12
1246	5/64	1"	2"	12
1247	3/32	1-1/4	2-1/4	12
1248	7/64	1-1/2	2-5/8	12
1249	1/8	1-1/2	2-3/4	12
1250	9/64	1-3/4	2-7/8	12
1251	5/32	2"	3-1/8	12
1252	11/64	2-1/8	3-1/4	12
1253	3/16	2-5/16	3-1/2	12
1254	13/64	2-7/16	3-5/8	12
1255	7/32	2-1/2	3-3/4	12
1256	15/64	2-5/8	3-7/8	12
1257	1/4	2-3/4	4"	12
1258	17/64	2-7/8	4-1/8	12
1259	9/32	2-15/16	4-1/4	12
1260	19/64	3-1/16	4-3/8	6
1261	5/16	3-3/16	4-1/2	6
1262	21/64	3-5/16	4-5/8	6
1263	11/32	3-7/16	4-3/4	6
1264	23/64	3-1/2	4-7/8	6
1265	3/8	3-5/8	5"	6
1266	25/64	3-3/4	5-1/8	6
1267	13/32	3-7/8	5-1/4	6
1268	27/64	3-3/4	5-3/8	6
1269	7/16	4-1/16	5-1/2	6
1270	29/64	4-3/16	5-5/8	6
1271	15/32	4-5/16	5-3/4	6
1272	31/64	4-3/8	5-7/8	6
1273	1/2	4-1/2	6"	6

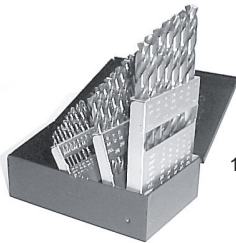

**29 PC. BRUTE DRILL SET**  
1/16 TO 1/2 BY 64THS, STRAIGHT SHANK  
**PART NO. 1499 (INDEX #6003)**



**128 PC. BRUTE DRILL ASSORTMENT**  
1/16 TO 1/2 BY 32THS, STRAIGHT SHANK  
IN 3-DRAWER DRILL DISPENSER  
**PART NO. 5900 (DISPENSER #6000)**

**21 PC. BRUTE DRILL SET**  
1/16 TO 3/8 BY 64THS, STRAIGHT SHANK  
**PART NO. 5994 (INDEX #5971)**

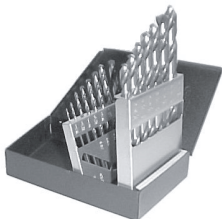
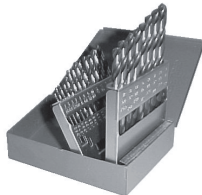

**15 PC. BRUTE DRILL SET**  
1/16 TO 1/2 BY 32THS, STRAIGHT SHANK  
**PART NO. 5995 (INDEX #5970)**



**7 PC. BRUTE DRILL SET**  
1/16 TO 1/4 BY 32THS, STRAIGHT SHANK  
IN PLASTIC POUCH. **PART NO. 5996**

# Cobalt Drills



## Straight Shank, Jobbers Length

Meets NAS 907 Type J specifications. 135° split point

Designed for drilling high tensile alloys, high nickel stainless steels, and other "hard to machine" metals. Manufactured from M42 cobalt steel, these drills withstand the heat generated when drilling high tensile materials. Extra heavy web geometry gives this drill extreme rigidity, requiring greater feed pressure to penetrate. Special gold-oxide chrome surface treatment reduces friction and temperature extremes. Recommended for use in fixed applications (drill presses) only.

135° split point.

No center-punching required.



Part No.	Diameter	Flute Length	Overall Length	Pkg Qty
6011	1/16	7/8	1-7/8	12
6012	5/64	1"	2"	12
6013	3/32	1-1/4	2-1/4	12
6014	7/64	1-1/2	2-5/8	12
6015	1/8	1-5/8	2-3/4	12
6016	9/64	1-3/4	2-7/8	12
6017	5/32	2"	3-1/8	12
6018	11/64	2-1/8	3-1/4	12
6019	3/16	2-5/16	3-1/2	12
6020	13/64	2-7/16	3-5/8	12
6021	7/32	2-1/2	3-3/4	12
6022	15/64	2-5/8	3-7/8	12
6023	1/4	2-3/4	4"	12
6024	17/64	2-7/8	4-1/8	12
6025	9/32	2-15/16	4-1/4	12
6026	19/64	3-1/16	4-3/8	6
6027	5/16	3-3/16	4-1/2	6
6028	21/64	3-5/16	4-5/8	6
6029	11/32	3-7/16	4-3/4	6
6030	23/64	3-1/2	4-7/8	6
6031	3/8	3-5/8	5"	6
6032	25/64	3-3/4	5-1/8	6
6033	13/32	3-7/8	5-1/4	6
6034	27/64	3-15/16	5-3/8	6
6035	7/16	4-1/16	5-1/2	6
6036	29/64	4-3/16	5-5/8	6
6037	15/32	4-5/16	5-3/4	6
6038	31/64	4-3/8	5-7/8	6
6039	1/2	4-1/2	6"	6



**29 PC. COBALT DRILL SET**  
1/16 TO 1/2 BY 64THS, STRAIGHT SHANK  
**PART NO. 6010 (INDEX #6003)**

Sizes not shown may be available on special request.

# Drill Gauge Plates

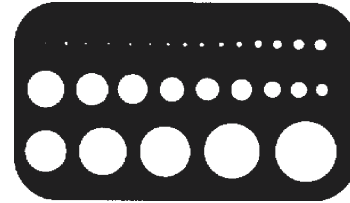

Hardened steel, satin chrome finish. Offers a quick and accurate method of checking drill and rod sizes.

Part No.	Size Range	Pkg
10-550	#1 - #60	1
10-551	1/16" - 1/2" by 64ths	1
10-552	A - Z	1
10-553	1.0 - 5.9 mm	1
10-554	1.5 - 12.5 mm	1

# Multi-Step Drills

(Pictures not actual size)

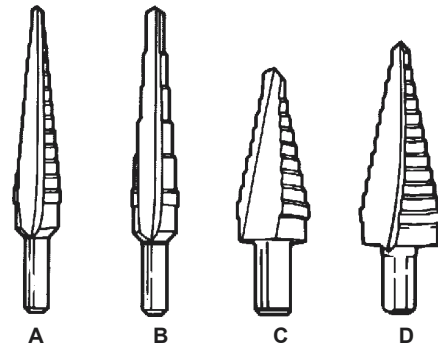

Self-starting points. Made from M-2 high speed steel. Drills and reams multiple size holes in steel, copper, aluminum, plastic, wood and drywall. Does the job of up to 13 individual drill bits. Perfect for enlarging existing holes. Pkg: 1 each.

To drill the desired hole size use a washer as a stop or count the steps as the drill penetrates the work. To double the cutting depth drill from both sides of the material.

Part No.	Max. Hole Size	Min. Hole Size	Incr-ment	No. of Sizes	Shank Size	Step Thick.	Fig.
1521	1/2"	1/8"	1/32"	13	1/4"	1/8"	A
1522	1/2"	3/16"	1/16"	6	1/4"	3/8"	B
1523	3/4"	1/4"	1/16"	9	3/8"	1/8"	C
1096	7/8"	3/16"	1/16"	12	3/8"	1/8"	D
1097	1-1/8"	7/16"	1/16"	12	3/8"	1/8"	-
1098	1-3/8"	3/4"	1/16"	11	1/2"	1/8"	-
1099	1-1/2"	1/4"	1/8"	11	1/2"	1/8"	-



# Letter Gauge Brute™ Aircraft Drills



Brute™ Platinum with *NOMO*® surface treatment. Straight shank, jobbers length. 135° split points - no center punching required.

Part No.	Diameter Letter	Diameter Decimal	Flute Length	Overall Length	Pkg Qty
1017	A	.2340	2-5/8	3-7/8	12
1018	B	.2380	2-3/4	4"	12
1019	C	.2420	2-3/4	4"	12
1020	D	.2460	2-3/4	4"	12
1021	E	.2500	2-3/4	4"	12
1022	F	.2570	2-7/8	4-1/8	12
1023	G	.2610	2-7/8	4-1/8	12
1024	H	.2660	2-7/8	4-1/8	12
1025	I	.2720	2-7/8	4-1/8	12
1026	J	.2770	2-7/8	4-1/8	12
1027	K	.2810	2-15/16	4-1/4	12
1028	L	.2900	2-15/16	4-1/4	12
1029	M	.2950	3-1/16	4-3/8	6
1030	N	.3020	3-1/16	4-3/8	6
1031	O	.3160	3-3/16	4-1/2	6
1032	P	.3230	3-5/16	4-5/8	6
1033	Q	.3320	3-7/16	4-3/4	6
1034	R	.3390	3-7/16	4-3/4	6
1035	S	.3480	3-1/2	4-7/8	6
1036	T	.3580	3-1/2	4-7/8	6
1037	U	.3680	3-5/8	5"	6
1038	V	.3770	3-5/8	5"	6
1039	W	.3860	3-3/4	5-1/8	6
1040	X	.3970	3-3/4	5-1/8	6
1041	Y	.4040	3-7/8	5-1/4	6
1042	Z	.4130	3-7/8	5-1/4	6



**26 PC. BRUTE LETTER GAUGE DRILL SET**  
SIZES A TO Z, STRAIGHT SHANKS  
PART NO. 5997 (INDEX #6005)

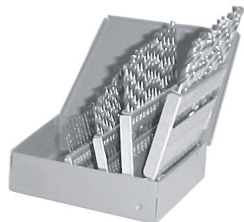

**60 PC. BRUTE WIRE GAUGE DRILL SET**  
SIZES 1 TO 60, STRAIGHT SHANKS  
PART NO. 5998 (INDEX #6004)

# Wire Gauge Brute™ Aircraft Drills



Brute™ Platinum with *NOMO*® surface treatment. Straight shank, jobbers length. 135° split points. Pkg: 12 each

Part No.	Wire Size	Decimal Size	Flute Length	Overall Length
1043	1	.2280	2-5/8	3-7/8
1044	2	.2210	2-5/8	3-7/8
1045	3	.2130	2-1/2	3-3/4
1046	4	.2090	2-1/2	3-3/4
1047	5	.2055	2-1/2	3-3/4
1048	6	.2040	2-1/2	3-3/4
1049	7	.2010	2-7/16	3-5/8
1050	8	.1990	2-7/16	3-5/8
1051	9	.1960	2-7/16	3-5/8
1052	10	.1935	2-7/16	3-5/8
1053	11	.1910	2-5/16	3-1/2
1054	12	.1890	2-5/16	3-1/2
1055	13	.1850	2-5/16	3-1/2
1056	14	.1820	2-3/16	3-3/8
1057	15	.1800	2-3/16	3-3/8
1058	16	.1770	2-3/16	3-3/8
1059	17	.1730	2-3/16	3-3/8
1060	18	.1695	2-1/8	3-1/4
1061	19	.1660	2-1/8	3-1/4
1062	20	.1610	2-1/8	3-1/4
1063	21	.1590	2-1/8	3-1/4
1064	22	.1570	2"	3-1/8
1065	23	.1540	2"	3-1/8
1066	24	.1520	2"	3-1/8
1067	25	.1495	1-7/8	3"
1068	26	.1470	1-7/8	3"
1069	27	.1440	1-7/8	3"
1070	28	.1405	1-3/4	2-7/8
1071	29	.1360	1-3/4	2-7/8
1072	30	.1285	1-5/8	2-3/4
1073	31	.1200	1-5/8	2-3/4
1074	32	.1160	1-5/8	2-3/4
1075	33	.1130	1-1/2	2-5/8
1076	34	.1110	1-1/2	2-5/8
1077	35	.1100	1-1/2	2-5/8
1078	36	.1065	1-7/16	2-1/2
1079	37	.1040	1-7/16	2-1/2
976	38	.1015	1-7/16	2-1/2
1081	39	.0995	1-3/8	2-3/8
1082	40	.0980	1-3/8	2-3/8
1083	41	.0960	1-3/8	2-3/8
1084	42	.0935	1-1/4	2-1/4
1085	43	.0890	1-1/4	2-1/4
1086	44	.0860	1-1/8	2-1/8
1087	45	.0820	1-1/8	2-1/8
1088	46	.0810	1-1/8	2-1/8
1089	47	.0785	1"	2"
977	48	.0760	1"	2"
1091	49	.0730	1"	2"
1092	50	.0700	1"	2"
1093	51	.0670	1"	2"
1094	52	.0635	7/8	1-7/8



# Wire Gauge Size Jobbers Length Drills



Straight shanks. High speed steel. Black oxide surface treatment. 135° or 118° standard points. Pkg: 12 each

Part No.	Wire	Decimal	Flute Length	Overall Length
1427•	53	.0595	7/8	1-7/8
1428•	54	.0550	7/8	1-7/8
1429•	55	.0520	7/8	1-7/8
1430•	56	.0465	3/4	1-3/4
1431•	57	.0430	3/4	1-3/4
1432•	58	.0420	11/16	1-5/8
1433•	59	.0410	11/16	1-5/8
1434•	60	.0400	11/16	1-5/8
50-139	61	.0390	11/16	1-5/8
50-140	62	.0380	5/8	1-1/2
50-141	63	.0370	5/8	1-1/2
50-142	64	.0360	5/8	1-1/2
50-143	65	.0350	5/8	1-1/2
50-144	66	.0330	1/2	1-3/8
50-145	67	.0320	1/2	1-3/8
50-146	68	.0310	1/2	1-3/8
50-147	69	.0292	1/2	1-3/8
50-148	70	.0280	3/8	1-1/4
50-149	71	.0260	3/8	1-1/4
50-150	72	.0250	5/16	1-1/8
50-151	73	.0240	5/16	1-1/8
50-152	74	.0225	1/4	1"
50-153	75	.0210	1/4	1"
50-154	76	.0200	3/16	7/8
50-155	77	.0180	3/16	7/8
50-156	78	.0160	3/16	7/8
50-157	79	.0145	1/8	3/4
50-158	80	.0135	1/8	3/4

• Sizes 53 to 60 have 135° standard point, all others are 118° standard point (no split points).

**SAVE WHEN YOU  
BUY IN QUANTITY!**

VISIT OUR WEBSITE  
[mpi-online.com](http://mpi-online.com)

FAX ANYTIME!  
**219-696-6413**

# Three-Flute 82° Countersinks

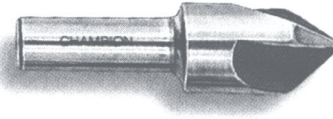

Three-flute countersinks are a good choice for fixed and portable operations. Chatter-free performance with less chipping than single-flute countersinks. Used for countersinking, deburring and chamfering operations. High speed steel.



Part No.	Body Size	Shank Diam.
6084	3/8" (.3750)	1/4
6085	1/2" (.5000)	3/8
6086	5/8" (.6250)	3/8
6087	3/4" (.7500)	1/2
6088	1" (1.0000)	1/2

## FLAT HEAD SCREW (COUNTERSUNK) HEAD DIAMETERS

SCREW DIAMETER	MAXIMUM HEAD DIA. (INCHES)
INCH SIZES	
6	.307"
8	.359"
10	.411"
1/4	.531"
5/16	.656"
3/8	.781"
7/16	.844"
1/2	.938"
5/8	1.180"
3/4	1.438"
METRIC SIZES	
M3	.265"
M4	.353"
M5	.441"
M6	.529"
M8	.706"
M10	.882"
M12	1.058"
M14	1.191"
M16	1.323"
M20	1.587"



# Large Straight Shank Twist Drills

(Taper Length Drills)



High speed steel, straight shank.  
118° standard point, surface treated. Pkg: 1 each

Part No.	Diameter	Flute Length	Overall Length
1307	17/32	4-3/4	8"
1309	9/16	4-7/8	8-1/4
1311	19/32	4-7/8	8-3/4
1313	5/8	4-7/8	8-3/4
1315	21/32	5-1/8	9"
1317	11/16	5-3/8	9-1/4
1319	23/32	5-5/8	9-1/2
1321	3/4	5-7/8	9-3/4
1323	25/32	6"	9-7/8
1325	13/16	6-1/8	10"
1327	27/32	6-1/8	10"
1329	7/8	6-1/8	10"
1331	29/32	6-1/8	10"
1333	15/16	6-1/8	10-3/4
1335	31/32	6-3/8	11"
1337	1"	6-3/8	11"

# Aircraft Extension Drills



High Speed Steel. 135° split point. No center punching required. Bright finish.

Part No.	Dia.	Length	Flute Length	Pkg Qty
1225	3/16	12"	2-5/16	1
1226	1/4	12"	2-3/4	1
1227	5/16	12"	3-3/16	1
1228	3/8	12"	3-5/8	1
1229	7/16	12"	4-1/16	1
1230	1/2	12"	4-1/2	1

Other lengths and diameters available upon request.

# Reduced Shank Twist Drills



## 1/4" Reduced Shank

118° standard point, high speed steel.

Part No.	Diameter	Flute Length	Overall Length	Pkg Qty
1338	17/64	2-1/8	3-1/2	6
1339	9/32	2-3/16	3-9/16	6
1340	19/64	2-5/16	3-11/16	6
1341	5/16	2-7/16	3-13/16	6
1342	21/64	2-1/2	3-15/16	6
1343	11/32	2-9/16	4"	6
1344	23/64	2-11/16	4-1/8	6
1345	3/8	2-13/16	4-1/4	6
1346	25/64	3-3/4	5-1/8	6
1347	13/32	3-7/8	5-1/4	6
1348	27/64	3-15/16	5-3/8	6
1349	7/16	4-1/16	5-1/2	6
1350	29/64	4-3/16	5-5/8	6
1351	15/32	4-5/16	5-3/4	6
1352	31/64	4-3/8	5-4/8	6
1353	1/2	4-1/2	6"	6



## 3/8" Reduced Shank

118° Standard Point, High Speed Steel

Part No.	Diameter	Flute Length	Overall Length	Pkg Qty
1100	25/64	3-1/4	5-1/8	6
1101	13/32	3-7/8	5-1/4	6
1102	27/64	3-15/16	5-3/8	6
1103	7/16	4-1/16	5-5/8	6
1104	29/64	4-3/16	5-5/8	6
1105	15/32	4-5/16	5-3/4	6
1106	31/64	4-3/8	5-7/8	6
1107	1/2	4-1/2	6"	6

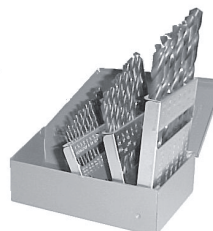

**29 PC. BRUTE 3/8" SHANK DRILL SET**  
1/16 TO 1/2 BY 64THS  
1/16" TO 3/8" ARE STRAIGHT SHANK,  
5/64" TO 1/2" ARE 3/8" REDUCED SHANK  
**PART NO. 5989 (INDEX #6003)**

# 1/2" Shank Silver & Deming Drills

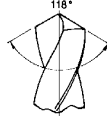
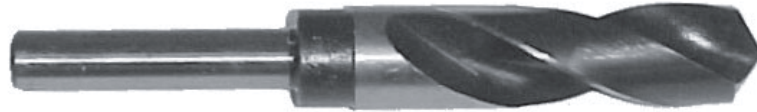

High Speed Steel  
Black & Bright Finish  
118° Standard Point

Part No.	Diameter	Flute Length	Overall Length	Pkg Qty	Part No.	Diameter	Flute Length	Overall Length	Pkg Qty
1500	33/64	3-1/8	6"	1	1370	1"	3"	6"	1
1355	17/32	3-1/8	6"	1	1516	1-1/64	3"	6"	1
1501	35/64	3-1/8	6"	1	1517	1-1/32	3"	6"	1
1356	9/16	3-1/8	6"	1	1371	1-1/16	3"	6"	1
1502	37/64	3-1/8	6"	1	1518	1-3/32	3"	6"	1
1357	19/32	3-1/8	6"	1	1372	1-1/8	3"	6"	1
1503	39/64	3-1/8	6"	1	1575	1-5/32	3"	6"	1
1358	5/8	3-1/8	6"	1	1373	1-3/16	3"	6"	1
1504	41/64	3-1/8	6"	1	1576	1-7/32	3"	6"	1
1359	21/32	3-1/8	6"	1	1374	1-1/4	3"	6"	1
1505	43/64	3-1/8	6"	1	1519	1-9/32	3"	6"	1
1360	11/16	3-1/8	6"	1	1108	1-19/64	3"	6"	1
1506	45/64	3-1/8	6"	1	1109	1-5/16	3"	6"	1
1361	23/32	3-1/8	6"	1	1110	1-21/64	3"	6"	1
1507	47/64	3-1/8	6"	1	1111	1-11/32	3"	6"	1
1362	3/4	3-1/8	6"	1	1112	1-23/64	3"	6"	1
1508	49/64	3"	6"	1	1113	1-3/8	3"	6"	1
1363	25/32	3"	6"	1	1114	1-25/64	3"	6"	1
1509	51/64	3"	6"	1	1115	1-13/32	3"	6"	1
1364	13/16	3"	6"	1	1116	1-27/64	3"	6"	1
1510	53/64	3"	6"	1	1117	1-7/16	3"	6"	1
1365	27/32	3"	6"	1	1118	1-29/64	3"	6"	1
1511	55/64	3"	6"	1	1119	1-15/32	3"	6"	1
1366	7/8	3"	6"	1	1120	1-31/64	3"	6"	1
1512	57/64	3"	6"	1	1121	1-1/2	3"	6"	1
1367	29/32	3"	6"	1					
1513	59/64	3"	6"	1					
1368	15/16	3"	6"	1					
1514	61/64	3"	6"	1					
1369	31/32	3"	6"	1					
1515	63/64	3"	6"	1					

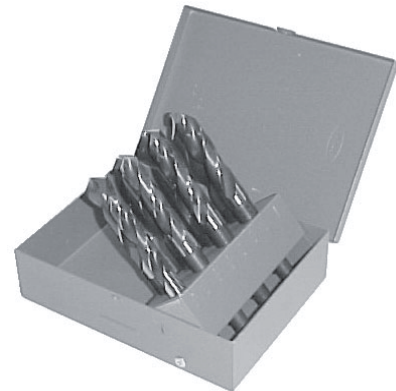

8 PC. SILVER & DEMING DRILL SET  
9/16 TO 1" BY 16THS, 1/2" SHANK  
PART NO. 5987 (INDEX #5967)

(LARGER SETS ALSO AVAILABLE)



For Brute™ Heavy Duty S&D Drills with split points, see page 324.



# Brute™ Silver & Deming Drills

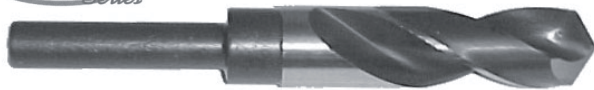

1/2" reduced shanks. Abrasion and heat resistant M-7 molybdenum high speed steel. Short rigid design. Drills tough, hard-to-cut materials. Special black and chrome finish extends life. 118° split point - no center punching required. Made in U.S.A.

Part No.	Diameter	Flute Length	Overall Length	Pkg Qty
1525	33/64	3-1/8	6"	1
1526	17/32	3-1/8	6"	1
1527	35/64	3-1/8	6"	1
1528	9/16	3-1/8	6"	1
1529	37/64	3-1/8	6"	1
1530	19/32	3-1/8	6"	1
1531	39/64	3-1/8	6"	1
1532	5/8	3-1/8	6"	1
1533	41/64	3-1/8	6"	1
1534	21/32	3-1/8	6"	1
1535	43/64	3-1/8	6"	1
1536	11/16	3-1/8	6"	1
1537	45/64	3-1/8	6"	1
1538	23/32	3-1/8	6"	1
1539	47/64	3-1/8	6"	1
1540	3/4	3-1/8	6"	1
1541	49/64	3"	6"	1
1542	25/32	3"	6"	1
1543	51/64	3"	6"	1
1544	13/16	3"	6"	1
1545	53/64	3"	6"	1
1546	27/32	3"	6"	1
1547	55/64	3"	6"	1
1548	7/8	3"	6"	1
1549	57/64	3"	6"	1
1550	29/32	3"	6"	1
1551	59/64	3"	6"	1
1552	15/16	3"	6"	1
1553	61/64	3"	6"	1
1554	31/32	3"	6"	1
1555	63/64	3"	6"	1
1556	1"	3"	6"	1
1557	1-1/16	3"	6"	1

# High Spiral Car Reamers



**CUTS FASTER THAN A DRILL BIT.  
LESS OPERATOR FATIGUE.  
SAFER, EASIER TO USE, AND LASTS LONGER  
THAN A DRILL BIT.**

**SAFETY STOP PREVENTS OVER-PENETRATION.  
NO HEAVY DRILLING EQUIPMENT REQUIRED.  
USE WITH ANY 1/2" DRILL.\***

1/2" Shank with Safety Collar, 5 Fluted Left Hand Spiral, Right Hand Cut, 8° Taper Lead, 30° Helix Angle, Premium M2 High Speed Steel

Specially designed for enlarging, aligning and deburring holes in automotive chassis, structural steel and thin free machining steels. The short length makes it very useful in cramped quarters. Designed for cutting various types of metals including mild and surface hardened steel, 4140 steel and cast iron. A safety collar stop prevents over penetration and injury to the operator.

*FOR BEST RESULTS...*

*Increase car reamer diameters in succession - starting with smaller sizes until the proper hole size is obtained. Use constant torque with even speed while applying cutting tool lubricant.*

Part No.	Size	Flute Length	Overall Length	Pilot Hole Size	Point Diam.
6801*	3/8	3-1/4	4-3/4	1/4	.230
6802*	7/16	3-1/4	4-3/4	9/32	.245
1219	1/2	3-3/8	5-3/4	5/16	.262
6803	9/16	3-3/8	5-3/4	11/32	.320
1220	5/8	3-7/8	6-3/16	3/8	.350
6804	11/16	3-7/8	6-3/16	7/16	.400
1221	3/4	4-1/4	6-3/4	1/2	.412
6805	13/16	4-1/4	6-3/4	9/16	.490
1222	7/8	4-7/8	7-1/8	5/8	.528
6806	15/16	4-7/8	7-1/8	5/8	.595
1223	1"	5"	7-3/16	3/4	.620

\* 3/8 reamers have a 3/8" shank. 7/16" reamers have a 7/16" shank. All other reamers have a 1/2" shank.

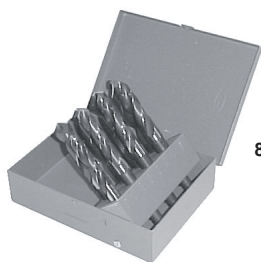

**8 PC. BRUTE™ SILVER & DEMING DRILL SET**  
9/16 TO 1" BY 16THS, 1/2" SHANK  
PART NO. 1558 (INDEX #5967)

(LARGER SETS ALSO AVAILABLE)

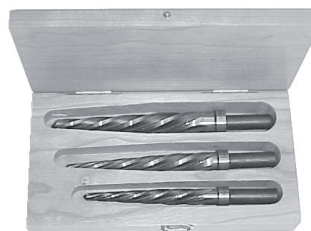

**3 PC. CAR REAMER SET**  
1/2", 5/8" AND 3/4" DIA., 1/2" SHANK  
IN WOOD BOX. PART NO. 1224

(MASTER SETS ALSO AVAILABLE)

# Sheeters Drills

(Stubby or Screw Machine drills)



Premium high speed steel, black oxide surface treatment, fast penetrating 135° split point. Rigid design for the automotive and metal building trade. Recommended for sheet metal, truck bodies and mobile home bodies. Also used in screw machine set-ups where spindle clearance is limited.

## FRACTIONAL SIZES

Part No.	Size	Flute Length	Overall Length	Pkg Qty
1122	3/64	1/2	1-3/8	12
1123	1/16	5/8	1-5/8	12
1124	5/64	11/16	1-11/16	12
1125	3/32	3/4	1-3/4	12
1200	7/64	13/16	1-13/16	12
1201	1/8	7/8	1-7/8	12
1202	9/64	15/16	1-15/16	12
1203	5/32	1"	2-1/16	12
1204	11/64	1-1/16	2-1/8	12
1205	3/16	1-1/8	2-3/16	12
1126	13/64	1-3/16	2-1/4	12
1206	7/32	1-1/4	2-3/8	12
1127	15/64	1-5/16	2-7/16	12
1207	1/4(E)	1-7/16	2-5/8	12
1128	17/64	1-7/16	2-5/8	12
1129	9/32	1-1/2	2-11/16	12
1130	19/64	1-9/16	2-3/4	6
1131	5/16	1-5/8	2-13/16	6
1132	21/64	1-11/16	2-15/16	6
1133	11/32	1-11/16	3"	6
1134	23/64	1-3/4	3-1/16	6
1135	3/8	1-13/16	3-1/8	6
1136	25/64	1-7/8	3-1/4	6
1137	13/32	1-15/16	3-5/16	6
1138	27/64	2"	3-3/8	6
1139	7/16	2-1/16	3-7/16	6
1140	29/64	2-1/8	3-9/16	6
1141	15/32	2-1/8	3-5/8	6
1142	31/64	2-3/16	3-11/16	6
1143	1/2	2-1/4	3-3/4	6

## SIZES FOR BLIND RIVETS

Part No.	Wire Size	For Rivet Dia.	Overall Length	Pkg Qty
1213	30	1/8	1-15/16	12
1144	20	5/32	2-1/4	12
1211	11	3/16	2-1/4	12
1145	F	1/4	2-5/8	12

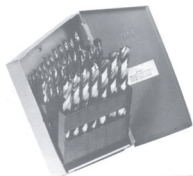

**29 PC. HSS SHEETERS DRILL SET**  
1/16 TO 1/2 BY 64THS, RIGHT HAND, STRAIGHT SHANKS. PART NO. 5986 (INDEX #6003)

# Double End Sheeters Drills



Premium high speed steel, black oxide surface treatment, fast penetrating 135° split point. Designed for maximum cost savings per hole.

Part No.	Size	Overall Length	Pkg Qty
1214	1/8	2"	12
1215	5/32	2-3/16	12
1216	3/16	2-1/4	12
1217	7/32	2-1/2	12
1218	1/4	2-1/2	12

# Left Hand Drills



Premium high speed steel, 118° standard point, jobbers length (unless marked otherwise). Use with any machinery with a left hand rotation. Commonly used as screw extractors for drilling out broken or frozen bolts and studs.

Part No.	Size	Overall Length	Pkg Qty
1146	5/64	2"	12
1231	3/32	2-1/4	12
1147	7/64	2-5/8	12
1232	1/8	2-3/4	12
1209	9/64	2-7/8"	12
1233	5/32	3-1/8	12
1234	3/16	3-1/2	12
1235	7/32	3-3/4	12
1242	15/64	3-7/8	12
1236	1/4	4"	12
1237	9/32	4-1/4	12
1148	19/64	4-3/8	6
1238	5/16	4-1/2	6
1238SM	5/16 (Sheeters)	2-13/16	6
1239	3/8	5"	6
1239SM	3/8 (Sheeters)	3-1/8	6
1240	7/16	5-1/2	6
1241	1/2	6"	6

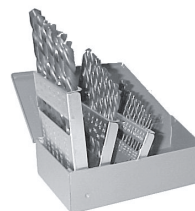

## NEW ITEM!

**29 PC. HSS LEFT HAND DRILL SET**  
1/16 TO 1/2 BY 64THS, RIGHT HAND, STRAIGHT SHANKS. PART NO. 5984 (INDEX #6003)



# Brute Mechanics Length Drills



## With Flatted Shanks\*

3/8 Reduced Shanks\*\*

Special High Speed Steel

135° split points, no centerpunching required



Designed specifically for small drills (3/8" and smaller drill chucks) for use in maintenance applications. Shorter than the jobbers length drill, the mechanics length drill provides better rigidity, yet it is longer than a screw machine length drill for extra depth. Three machined flats on the drill shank provide a positive chuck-grip to help eliminate slippage\*. Features self-centering 135° split points, heavy duty web geometry to minimize drill breakage, special black oxide surface treatment promotes cooler cutting. Applications: Medium and high strength steels, high tensile martensitic stainless steels and titanium alloys.

Part No.	Diameter	Flute Length	Overall Length	Pkg Qty
2100	1/16	7/8	1-7/8	12
2101	5/64	1"	2"	12
2102	3/32	1-1/4	2-1/4	12
2103	7/64	1-5/16	2-3/8	12
2104	1/8	1-7/16	2-1/2	12
2105	9/64	1-9/16	2-5/8	12
2106	5/32	1-11/16	2-3/4	12
2107	11/64	1-13/16	2-7/8	12
2108	3/16	1-7/8	3"	12
2109	13/64	1-15/16	3-1/8	12
2110	7/32	2"	3-1/4	12
2111	15/64	2-1/16	3-3/8	12
2112	1/4	2"	3-1/2	12
2113	17/64	2-1/8	3-5/8	12
2114	9/32	2-1/4	3-3/4	12
2115	19/64	2-3/8	3-7/8	6
2116	5/16	2-1/2	4"	6
2117	21/64	2-9/16	4-1/16	6
2118	11/32	2-5/8	4-1/8	6
2119	23/64	2-11/16	4-3/16	6
2120	3/8	2-11/16	4-1/4	6
2121	25/64	2-3/4	4-5/16	6
2122	13/32	2-13/16	4-3/8	6
2123	27/64	2-7/8	4-7/16	6
2124	7/16	2-15/16	4-1/2	6
2125	29/64	3"	4-5/8	6
2126	15/32	3-1/8	4-3/4	6
2127	31/64	3-1/4	4-7/8	6
2128	1/2	3-3/8	5"	6

\*Only 3/16" to 1/2" have flatted sides. \*\*3/8" to 1/2" have 3/8" shanks.

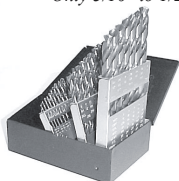

**29 PC. MECHANICS LENGTH DRILL SET**  
1/16 TO 1/2 BY 64THS, 3/8" REDUCED SHANKS\*\*  
**PART NO. 5901 (INDEX #6003)**

# Straight Flute Screw Extractors



Removes right or left hand threaded parts.

Part No.	Size	For Screw Size	Drill Required
50-262	1	1/4-5/16	1/8
50-263	2	3/8	3/16
50-264	3	7/16	15/64
50-265	4	1/2-9/16	5/16
50-266	5	5/8	3/8



**10 PC. STRAIGHT FLUTE SCREW EXTRACTOR KIT W/ L.H. DRILLS**  
#1 TO #5 EXTRACTORS WITH CORRESPONDING LEFT-HAND DRILLS IN A CLEAR BOX. **PART NO. 539MK**



**5 PIECE STRAIGHT FLUTE EXTRACTOR SET**  
# 1 TO #5 EXTRACTORS IN A VINYL POUCH. **PART NO. 50-267**

# Spiral Flute Screw Extractors



Part No.	Size	For Screw Size	For Pipe Size	Use Drill Size
50-252	1	3/32-5/32	-	5/64
50-253	2	5/32-7/32	-	7/64
50-254	3	7/32-9/32	-	5/32
50-255	4	9/32-3/8	-	1/4
50-256	5	3/8-5/8	1/8, 1/4	17/64
50-257	6	5/8-7/8	3/8	13/32
50-258	7	7/8 - 1-1/8	1/2	17/32
50-259	8	1-1/8-1-3/8	3/4	13/16
50-260	9	1-3/8-1-3/4	1"	1-1/16

Larger sizes available upon special request.



**10 PC SPIRAL EXTRACTOR SET W/ L.H. DRILLS** #1 TO #5 WITH CORRESPONDING LEFT HAND DRILLS IN A STURDY METAL INDEX. **PART NO. 5985**



**5PIECE SPIRAL EXTRACTOR SET** #1 TO #5 EXTRACTORS IN A VINYL POUCH. **PART NO. 50-261**

# DRILL-OUT® Power Extractors

Drill bit AND Extractor in one.

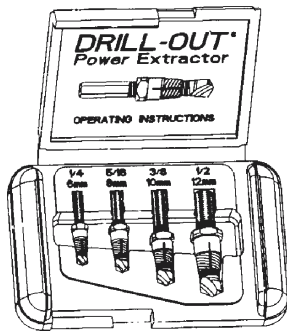

REGULAR SET

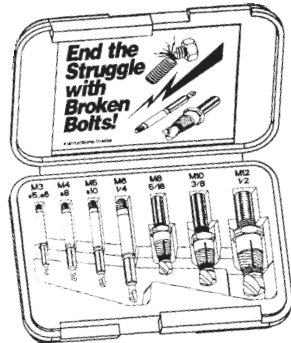

MICRO SET

## FINALLY AN EXTRACTOR THAT DOES THE JOB!

Drill bit AND extractor in one! Takes the frustration out of removing broken bolts. Use with your 3/8" reversible variable speed drill to remove broken bolts and studs in much less time than conventional extractors require. After drilling to 1/2" depth, screw the extractor down to top of the drill bit then extract bolt. Removes up to grade 8 alloy steel screws and studs. Precision ground 118°, left hand cutting drill with self-centering point. Will not walk or wander. Sturdy plastic carrying case and instructions included with each kit. The world's only power extractor! *Lifetime guarantee against breakage.* Made in the U.S.A.

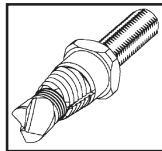

### REGULAR SIZES

5/16" to 1/2" or M8 to M12

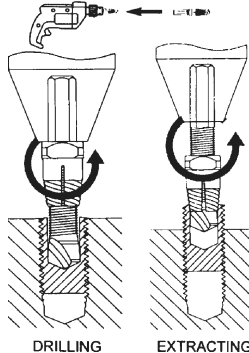

DRILLING EXTRACTING

### MICRO SIZES

1/8" to 1/4" or M3 to M6

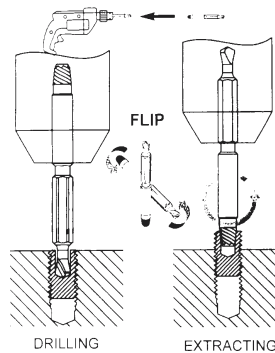

DRILLING EXTRACTING

### REGULAR DRILL-OUT® SET

Part No.	Description	Size Range
5964	4 piece kit	1/4" 5/16" 3/8" 1/2" M6, M8, M10, M12

### MICRO DRILL-OUT® SET

Part No.	Description	Size Range
5965	7 piece kit	6, 8, 10, 1/4", 5/16", 3/8", 1/2", M3, M4, M5, M6, M8, M10, M12

# Carbide Tipped Masonry Hammer Drills



Round Shank. Slow spiral flutes for fast dust removal. Heat treated alloy steel for shockproof rotary or percussion drilling. Quickly cuts hard and abrasive masonry materials. Pkg: 1 each

Part No.	Bit Dia.	Overall Length	Drilling Depth	Shank Dia.
1149	1/8	3"	1-1/2"	1/8
1150	5/32	3"	1-1/2"	5/32
1151	3/16	3"	1-1/2"	3/16
1152	1/4	4"	2-1/2"	1/4
1153	1/4	6"	4-1/2"	1/4
1154	1/4	13"	12"	1/4
1155	5/16	4"	2-1/2"	9/32
1156	5/16	6"	4-1/2"	9/32
1157	5/16	13"	12"	9/32
1158	3/8	4"	2-1/2"	11/32
1159	3/8	6"	4-1/2"	11/32
1160	3/8	13"	12"	11/32
1161	7/16	6"	4-1/2"	3/8
1162	1/2	6"	4-1/2"	3/8
1163	1/2	13"	12"	3/8
1164	5/8	6"	4-1/2"	1/2
1165	3/4	6"	4-1/2"	1/2
1166	7/8	6"	4-1/2"	1/2
1167	1"	6"	4-1/2"	1/2

# Concrete Screw Drills



The standard masonry drill supplied with concrete screws. Split shank configuration fits properly in the installation tool. High quality carbide tip. Black oxide finish. **Warning: Concrete screw drills have special dimensions, and a substitution may result in fastening failure.**

Part No.	Drill Size	For Screw Diameter
23-288	5/32 x 3-1/2"	3/16"
23-282	5/32 x 4-1/2"	3/16"
23-284	5/32 x 5-1/2"	3/16"
23-287	3/16 x 3-1/2"	1/4"
23-285	3/16 x 4-1/2"	1/4"
23-286	3/16 x 5-1/2"	1/4"



# "A" Taper Shank Masonry Hammer Drills

Designed for use in rotary hammer drills with standard A-Taper chucks, or use in combination with corresponding adapters. Patented flute design for faster dust removal. Cuts hard and abrasive masonry materials. Meets ANSI standards. Pkg: 1 each

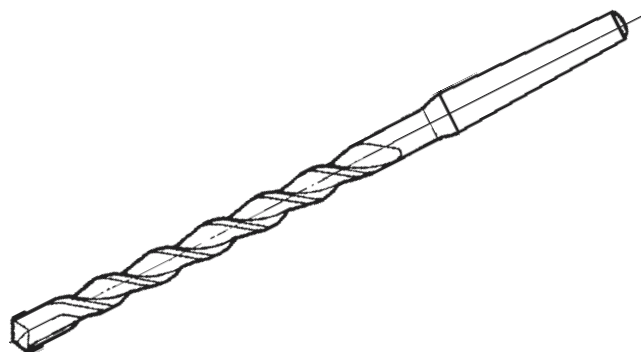

Part No.	Bit Dia.	Overall Length	Drilling Depth
1168	3/16	4"	2"
1169	3/16	6"	4"
1170	1/4	4"	2"
1171	1/4	8"	6"
1172	1/4	12"	10"
1173	5/16	4-1/2"	2-1/2"
1174	5/16	6"	4"
1175	3/8	6"	4"
1176	3/8	9"	7"
1177	3/8	12"	10"
1178	3/8	20"	18"
1179	7/16	6"	4"
1180	1/2	6"	4"
1181	1/2	9"	7"
1182	1/2	12"	10"
1183	1/2	20"	18"
1184	5/8	5"	3"
1185	5/8	9"	7"
1186	5/8	12"	10"
1187	5/8	18"	16"
1188	3/4	5-1/2"	3-1/2"
1189	3/4	9"	7"
1190	3/4	12"	10"
1191	3/4	18"	16"
1192	7/8	5"	3"
1193	7/8	9"	7"

*Hammer Drills available for "B" Taper Drills, SDS, Hilti, Skil, Milwaukee, Metabo, Phillips, B & D and many other machines.*

# "A" Taper Chuck Adapters With Drift Pin

Allows "A" Taper shank drills to be used in SDS, Spline, Hex and other types of drives from most power tool manufacturers. Made from heat treated alloy steel.



**Part No.** 1194 ..... **Description** SDS Adapter  
*For Hammer Drill Models; Hilti 17/ 12/ 22, Bosch 11207/ 11211, AEG PH210/ PHE16RL, B & D 5016-09, Hitachi YRT22A, Kango 327, Red Head 555/ 715, Ryobi ED211*

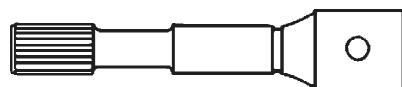

**Part No.** 1195 ..... **Description** Spline Adapter  
*For Hammer Drill Models; AEG PH38/PHD38/PH240/PH240D/PH350/PH350D, B & D 5041/42/43, Bosch 11202/3/4/5/9, Hitachi DH38VA, Metabo RH66/99/99X, Milwaukee 5343/47, Phillips 747-2, Ryobi ED382P*

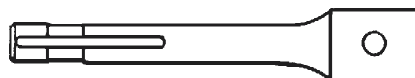

**Part No.** 1196 ..... **Description** Hilti Adapter  
*For Hammer Drill Models; Hilti TE 52/ 60/ 72/ 92*



**Part No.** 1197 ..... **Description** 7/16 Hex Shank Adapter  
*For Hammer Drill Models; Skil 726, Milwaukee 5300/05/10/15*

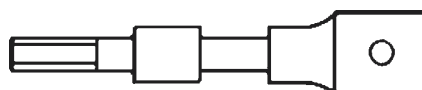

**Part No.** 1198 ..... **Description** 9/16 Hex Shank Adapter  
*For Hammer Drill Models; Milwaukee 5325/26, B & D 5048, Skil 728/731/732*



**Part No.** 1199 ..... **Description** Drift Pin

*Adapters for "B" Taper Chucks and other hammer drill brands available upon special request*



# Solid Carbide Burs

1/4" SHANKS. Made from C2 grade carbide for high performance metal removal. Features *DOUBLE CUT* flutes for rapid metal removal rates, smaller chips, and reduced pulling for better operator control. Made in U.S.A.

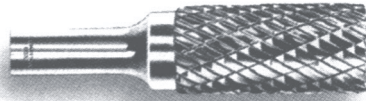

**CYLINDER SHAPE (SA)**

Part No.	Trade Ref. No.	Dia.	Lgth. of Cut	Max. R.P.M.*
1003	SA1	1/4	5/8	33,000
1004	SA3	3/8	3/4	27,000
1005	SA5	1/2	1"	24,000

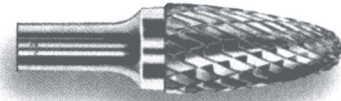

**TREE-RADIUS END (SF)**

Part No.	Trade Ref. No.	Dia.	Lgth. of Cut	Max. R.P.M.*
1010	SF1	1/4	5/8	22,000
1011	SF3	3/8	3/4	27,000
1012	SF5	1/2	1"	24,000

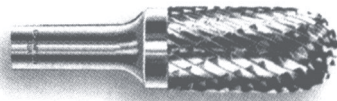

**CYLINDER-RADIUS END (SC)**

Part No.	Trade Ref. No.	Dia.	Lgth. of Cut	Max. R.P.M.*
1006	SC1	1/4	5/8	22,000
1007	SC3	3/8	3/4	27,000
1008	SC5	1/2	1"	24,000



**TREE-POINTED END (SG)**

Part No.	Trade Ref. No.	Dia.	Lgth. of Cut	Max. R.P.M.*
1013	SG1	1/4	5/8	22,000
1014	SG3	3/8	3/4	27,000
1015	SG5	1/2	1"	24,000

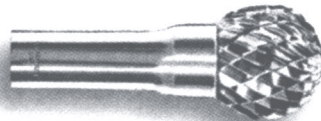

**BALL SHAPE (SD)**

Part No.	Trade Ref. No.	Dia.	Lgth. of Cut	Max. R.P.M.*
1009	SD5	1/2	7/16	24,000

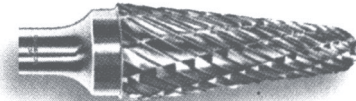

**14° TAPER-RADIUS END (SL)**

Part No.	Trade Ref. No.	Dia.	Lgth. of Cut	Max. R.P.M.*
1016	SL4	1/2	1-1/8	24,000

\* Maximum safe speed for all metal cutting.

Also available; Non-ferrous (N.F.) Burs for aluminum cutting, Miniature Burs, and Extra Long Burs.

## Carbide Bur Kit



8 Sizes - SA5, SC3, SC5, SD5, SF3, SF5, SG3, SL4 with double-cut flutes in hardwood case. Solid C2 carbide burs with 1/4" shanks. **Part No. 5983**

## Other Burs available on special request...



60° Cone Shape (SJ)



Cone Shape (SM)



Inverted Cone Shape (SN)



90° Cone Shape (SK)



1/8 Shank Mini Burs (SE51 shown)



NF Burs for Aluminum (SA/NF shown)



Cylinder-End Cut (SB)



Flame Shape (SH)



Oval Shape (SE)



# Drill Chuck Keys

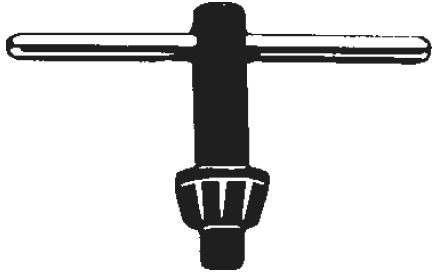

Genuine Jacobs brand chuck keys are made in U.S.A. Pkg. 1 each

Part No.	Jacobs Key No.	Chuck Size	Pilot Size
29-398	K1	1/4	5/32
<i>For Jacobs chuck no.s 1A, 1B3/8, 7BA3/8</i>			
29-399	KG	1/4, 3/8	1/4
<i>For Jacobs chuck no.s SM1G61, DC4G61-T1, SM4G61-T1</i>			
29-402	K30	3/8	15/64
<i>For Jacobs chuck no.s 31-01, 31-02, 31BA3/8, 31BA1/2</i>			
29-403	KK	3/8, 1/2	9/32
<i>For Jacobs chuck no.s DC8K61-T1, SM8K61, DC8K64-T1, SM8K64-T1, SM8K33-T1</i>			
29-404	K2	3/8	1/4
<i>For Jacobs chuck no.s 2A, 2BA3/8</i>			
29-405	K7	3/8	7/32
<i>Fits Jacobs chuck model 7BA3/8</i>			
29-406	K32	1/2	1/4
<i>For Jacobs chuck no.s 33, 3326A, 33BA3/8, 33BA1/2, 33BA5/8, 33KD</i>			
29-407	K3	1/2	5/16
<i>For Jacobs chuck no.s 34-02, 34-06, 34-33, 34-33C, 3A, 3B5/8, 3KD, 3PD</i>			

NOTE: Chuck Keys not listed available on special request. Include key number, brand, or model number of chuck when ordering. Drill Chucks also available.

# Combination Drill / Tap

High Speed Steel, 118° Point, GH-3 thread limits. Allows two operations in one set-up or may be used as a standard tap. Designed for thread cutting in *deep* or *through* holes.

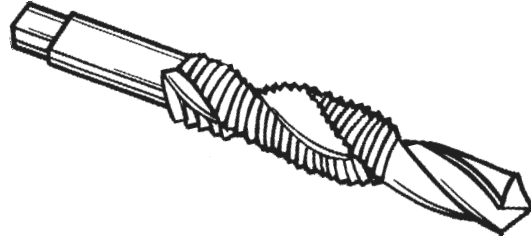

Part No.	Tap Size	Overall Lg.	Thread Lg.	Drill Lg.	Drill Dia.
6386	6-32 NC	2"	13/32	1/4	.112
6387	8-32 NC	2-1/8	15/32	9/32	.138
6388	10-24 NC	2-3/8	9/16	9/32	.155
6389	10-32 NF	2-3/8	1/2	9/32	.164
6390	1/4-20 NC	2-1/2	23/32	7/16	.208
6391	1/4-28 NF	2-1/2	23/32	7/16	.220
6392	5/16-18 NC	2-23/32	27/32	9/16	.266
6393	5/16-24 NF	2-23/32	13/16	9/16	.277
6394	3/8-16 NC	2-15/16	1"	21/32	.322
6395	3/8-24 NF	2-15/16	15/16	21/32	.340

## INSTRUCTIONS FOR USING COMBINATION DRILL-TAPS

Fix the work-piece securely to surface. Always use plenty of cutting lubricant such as BruteLube. Try to avoid any binding of the tool, especially with portable electric drills. DO NOT USE EXCESSIVE FORCE. Ease Drill-Tap into material carefully. Operate Combination Drill-Taps at *slow speed only*.

**WARNING:** Make certain the work-piece is *fixed securely to surface or drilling table*. Movement of work-piece or portable tools may cause tool breakage or serious bodily injury.

## Master Chuck Key

**DISCONTINUED ITEM**

Why keep a set of individual keys on hand when one key will get the job done? Made of carbon steel. Designed to fit 60 different drill chucks. Part No. 29-413

## Chuck Key Holder



Forget about lost or misplaced chuck keys. these holders attach to your power cord to securely hold your chuck key to power cord. **Part No. 29-408**

## The Drill Saw



Saws, reams and drills woods, plywood, plastics, brass and aluminum. Cross-milled cutting edges for rapid non-clog cutting. Works in both portable drills and drill presses. Use for speed cutting outlet holes in drywall, truck mudflap bolt holes and more.. Made in U.S.A.

Part No.	Diameter	Overall Length	Pkg Qty
975	1/4	3-3/4	1

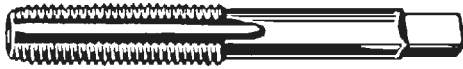

# High Speed Taps

High Speed Steel.  
Ground Threads.  
Standard "H" Limits.



## TAPER TAPS

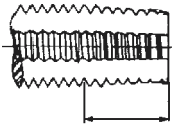

8-10 THREADS  
CHAMFER LENGTH

Tapered for easy starting of new threads. Also called Starter Taps.

## PLUG TAPS

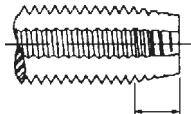

3-5 THREADS  
CHAMFER LENGTH

Can be used for threading new holes, or cleaning up damaged threads. Also called *Universal* Taps.

## BOTTOMING TAPS

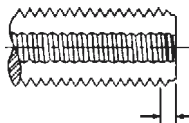

1/2-1-1/2 THREADS  
CHAMFER LENGTH

Use to put threads to the *bottom* of blind holes after using Taper or Plug Taps.

COARSE THREAD HAND TAPS (NC)						
TAP SIZE	TAPER (STARTER)	PLUG (UNIVERSAL)	BOTTOMING (FINISHING)	NO. OF FLUTES	THREAD LIMITS	PKG QTY
1-64	-	6151	-	2	H2	12
2-56	6155	6154	6156	3	H3	12
3-48	6161	6160	6162	3	H3	12
4-40	6167	6166	6168	3	H3	12
5-40	6173	6172	6174	3	H3	12
6-32	6179	6178	6180	3	H3	12
8-32	6185	6184	6186	4	H3	12
10-24	6191	6190	6192	4	H3	12
12-24	6197	6196	6198	4	H3	12
1/4-20	6206	6205	6207	4	H3	12
5/16-18	6209	6208	6210	4	H3	12
3/8-16	6212	6211	6213	4	H3	6
7/16-14	6215	6214	6216	4	H3	6
1/2-13	6218	6217	6219	4	H3	6
9/16-12	6221	6220	6222	4	H3	1
5/8-11	6224	6223	6225	4	H3	1
3/4-10	6227	6226	6228	4	H3	1
7/8-9	6230	6229	6231	4	H4	1
1-8	6233	6232	6234	4	H4	1
1-1/8-7	50-532	50-530	50-531	4	H4	1
1-1/4-7	6236	6235	6237	4	H4	1
1-3/8-6	50-538	50-536	50-537	4	H4	1
1-1/2-6	6239	6238	6240	4	H4	1

FINE THREAD HAND TAPS (NF)						
TAP SIZE	TAPER (STARTER)	PLUG (UNIVERSAL)	BOTTOMING (FINISHING)	NO. OF FLUTES	THREAD LIMITS	PKG QTY
0-80	-	6149	6150	2	H2	12
1-72	-	6152	6153	2	H2	12
2-64	6158	6157	6159	3	H2	12
3-56	6164	6163	6165	3	H2	12
4-48	6170	6169	6171	3	H2	12
5-44	6176	6175	6177	3	H2	12
6-40	6182	6181	6183	3	H3	12
8-36	6188	6187	6189	4	H3	12
10-32	6194	6193	6195	4	H3	12
12-28	6200	6199	6201	4	H3	12
1/4-28	6242	6241	6243	4	H3	12
5/16-24	6245	6244	6246	4	H3	12
3/8-24	6248	6247	6249	4	H3	6
7/16-20	6251	6250	6252	4	H3	6
1/2-20	6254	6253	6255	4	H3	6
9/16-18	6257	6256	6258	4	H3	1
5/8-18	6260	6259	6261	4	H3	1
3/4-16	6263	6262	6264	4	H3	1
7/8-14	6266	6265	6267	4	H4	1
1-14	6269	6268	6270	4	H4	1
1-1/8-12	50-574	50-572	50-573	4	H4	1
1-1/4-12	6272	6271	6273	6	H4	1
1-3/8-12	50-580	50-578	50-579	6	H4	1
1-1/2-12	6275	6274	6276	6	H4	1



# Hand Tap Sets

Consists of taper, plug, & bottoming style taps. High speed steel, ground threads, standard flute and H-limit.



UNC Part No.	Size	UNF Part No.	Size
6117	4-40	6118	4-48
6119	5-40	6120	5-44
6121	6-32	6122	6-40
6123	8-32	6124	8-36
6125	10-24	6126	10-32
6127	12-24	6128	12-28
6129	1/4-20	6130	1/4-28
6131	5/16-18	6132	5/16-24
6133	3/8-16	6134	3/8-24
6135	7/16-14	6136	7/16-20
6137	1/2-13	6138	1/2-20
6139	9/16-12	6140	9/16-18
6141	5/8-11	6142	5/8-18
6143	3/4-10	6144	3/4-16
6145	7/8-9	6146	7/8-14
6147	1-8	6148	1-14

# Taper Pipe Taps



National pipe threads. Use high speed steel for tough jobs requiring a quality finish. Use carbon steel taps for occasional use on mild steels. Pkg: 1 each

NPT Size	No. Flutes	Overall Length	High Speed	Carbon Steel
1/8-27	4	2-1/8	6277	6376
1/4-18	4	2-1/8	6278	6377
3/8-18	4	2-9/16	6279	6378
1/2-14	4	3-1/8	6280	6379
3/4-14	5	3-1/4	6281	6380
1-11-1/2	5	3-3/4	6282	6381
1-1/4-11-1/2	5	4-1/2	6283	6382
1-1/2-11-1/2	7	4-1/2	6284	6383
2-11-1/2	7	4-1/2	50-632	6384

# Brute™ Spiral Point Taps

(Gun Taps)

**GROUND THREAD - HIGH SPEED STEEL  
DESIGNED FOR DEEP OR THROUGH HOLES.**

Specially designed flute angle efficiently *pushes* chip material ahead and away from the cutting threads, to avoid clogging and breakage of tap. Brute Spiral Point Taps provide cleaner cuts, resulting in more precise thread tolerances. Brute Spiral Point Taps stay sharper longer than standard hand taps and require less effort to use. Universal plug style, 3-flutes. Special high speed steel. Surface treated for added lubricity. Ground threads to H3 limits.

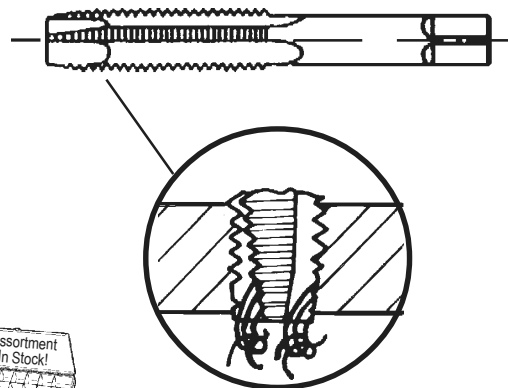

Part No.	Size	Thread Length	Overall Length	Pkg Qty
COARSE THREAD (UNC)				
6330	6-32	11/16	2"	12
6331	8-32	3/4	2-1/8	12
6332	10-24	7/8	2-3/8	12
6333	12-24	15/16	2-3/8	12
6334	1/4-20	1"	2-1/2	12
6335	5/16-18	1-1/8	2-23/32	12
6336	3/8-16	1-1/4	2-15/16	12
6337	7/16-14	1-7/16	3-5/32	12
6338	1/2-13	1-21/32	3-3/8	12
FINE THREAD (UNF)				
6374	6-40	11/16	2"	12
6375	8-36	3/4	2-1/8	12
6343	10-32	7/8	2-3/8	12
6344	12-28	15/16	2-3/8	12
6345	1/4-28	1"	2-1/2	12
6346	5/16-24	1-1/8	2-23/32	12
6347	3/8-24	1-1/4	2-15/16	12
6348	7/16-20	1-7/16	3-5/32	12
6349	1/2-20	1-21/32	3-3/8	12

# Metric Plug Taps

## Metric Tap-Drill Sizes

DIAMETER x PITCH	COARSE / FINE	RECOMMENDED TAP-DRILL SIZE	NEAREST EQUIVALENT TAP-DRILL SIZE
M2 x 0.4	C	1.6 mm (.0630")	1/16" (.0625")
M2.5 x 0.45	C	2.05 mm (.0807")	#46 (.0810")
M3 x 0.5	C	2.5 mm (.0984")	#40 (.0980")
M4 x 0.7	C	3.4 mm (.1339")	#30 (.1285")
M5 x 0.8	C	4.2 mm (.1654")	#20 (.1610")
M6 x 1.0	C	5 mm (.1969")	#9 (.1960")
M7 x 1.0	C	6 mm (.2362")	15/64" (.2344")
M8 x 1.25	C	6.9" (.2717")	Ltr. I (.2720")
M8 x 1.0	F	7.1 mm (.2795")	Ltr. J (.2770")
M10 x 1.5	C	8.5 mm (.3346")	Ltr. Q (.3320")
M10 x 1.25	F	8.9 mm (.3504")	Ltr. S (.3480")
M10 x 1.0	F	9.1 mm (.3583")	Ltr. T (.3580")
M12 x 1.75	C	10.2 mm (.4015")	Ltr. X (.3970")
M12 x 1.5	F	10.5 mm (.4134")	Ltr. Z (.4130")
M12 x 1.25	F	11 mm (.4331")	27/64" (.4219")
M14 x 2.0	C	12 mm (.4724")	15/32" (.4688")
M14 x 1.5	F	12.5 mm (.4921")	31/64" (.4844")
M14 x 1.25	F	12.8 mm (.5039")	1/2" (.5000")
M16 x 2.0	C	14 mm (.5512")	35/64" (.5469")
M16 x 1.5	F	14.7 mm (.5787")	37/64" (.5781")
M18 x 2.5	C	15.5 mm (.6102")	39/64" (.6094")
M18 x 1.5	F	16.8 mm (.6614")	21/32" (.6562")
M20 x 2.5	C	17.5 mm (.6890")	11/16" (.6875")
M22 x 2.5	C	19.5 mm (.7677")	49/64" (.7656")
M24 x 3.0	C	21 mm (.8268")	53/64" (.8281")
M24 x 2.0	F	22.3 mm (.8779")	7/8" (.8750")

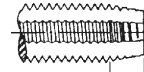

3-5 THREADS



Universal plug taps create new threads or clean up damaged threads. High speed steel, ground threads, standard flutes and D-limits. *Taper and bottoming available on request.*

PART NO.	TAP SIZE	THREAD PITCH	NO. OF FLUTES	THREAD D-LIMIT	DRILL SIZE	PKG QTY
50-800	M3	0.50 COARSE	3	3	#40	12
50-801	M4	0.70 COARSE	4	4	#30	12
50-802	M5	0.80 COARSE	4	4	#19	12
50-803	M6	1.00 COARSE	4	5	#9	12
50-804	M8	1.25 COARSE	4	5	H	6
50-811	M8	1.00 FINE	4	5	J	6
50-805	M10	1.50 COARSE	4	6	R	6
50-812	M10	1.25 FINE	4	5	S	6
50-806	M12	1.75 COARSE	4	6	13/32"	6
50-807	M14	2.00 COARSE	4	7	15/32"	1
50-808	M16	2.00 COARSE	4	7	35/64"	1
50-809	M18	2.50 COARSE	4	7	5/8"	1
50-810	M20	2.50 COARSE	4	7	11/16"	1



## Metric Bolt Gauge

Measures diameter, thread pitch and wrench size. Plastic. **Part No. 42-003**



## Metric Pitch Gage

Accurately measures 24 pitch sizes from .25mm - 6mm. Steel. **Part No. 7070**



**Red Hot Deals!**

Check out our current specials and new items on our website at <http://www.mpi-online.com>

## Tap Wrenches



Hardened steel jaws. Simply adjusts by turning knurled handle. *Can also be used with reamers.*

Part No.	Capacity
10-496 .....	#0 - 1/2"
10-494 .....	1/4 - 1"

## T-Handle Tap Wrenches

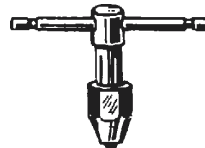

Sliding handle with spring tension stop. May be extended for more leverage.

Part No.	Capacity
6203 .....	#0 - 1/4"
6204 .....	1/4 - 1/2"

*Ratcheting tap wrenches available on request.*

# Brute Tap-Drill Sets



Unique dispenser quickly organizes taps with the correct twist drill size. Special heavy duty drills feature advanced metallurgy and sophisticated geometry which increase strength and durability. The 135° split point drills faster and requires less force to penetrate. Brute™ spiral point taps cut faster and require less torque than standard hand taps. Ideal for tapping steel and most any materials. Taps feature forward chip ejection for clean, accurate tapping. *Note: Spiral point taps are designed for through hole or deep hole threading only. Not for blind holes.*

Drills have 135° split points  
No center-punching required.

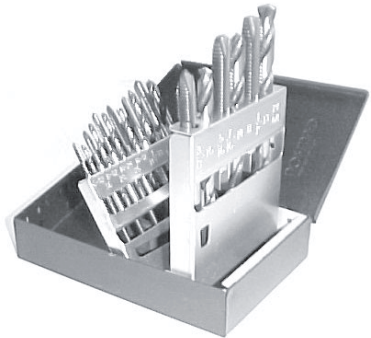

**18 PC. COARSE (UNC) THREAD TAP/DRILL SET**  
TAP SIZES - 6/32, 8/32, 10/24, 10/32, 1/4-20,  
5/16-18, 3/8-16, 7/16-14, 1/2-13  
DRILL SIZES - 36, 29, 25, 21, 7, F, 5/16, U, 27/64  
**PART NO. 5972 (INDEX #5966)**

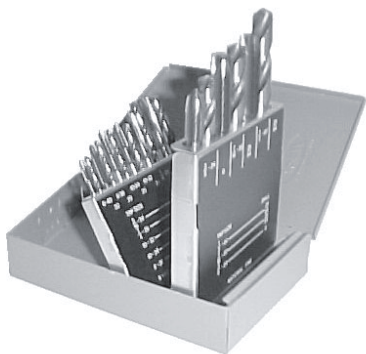

**18 PC. FINE (UNF) THREAD TAP/DRILL SET**  
TAP SIZES - 6/40, 8/36, 10/32, 12/28, 1/4-28,  
5/16-24, 3/8-24, 7/16-20, 1/2-20  
DRILL SIZES - 33, 29, 21, 15, 3, I, Q, 25/64, 29/64  
**PART NO. 5973 (INDEX #5969)**



# Tap & Die Sets

High carbon tool steel. Made in U.S.A.



## FRACTIONAL TAP & DIE SUPER SET

Made from the finest quality tool steel. Carbon steel plug taps, carbon steel hex dies, adjustable tap wrench, t-tap wrench, adjustable die stock, screwdriver, thread gauge, unbreakable plastic case.

### Tap & Die Sizes

Coarse: 4-40, 6-32, 8-32, 10-24, 12-24, 1/4-20, 5/16-18,  
3/8-16, 7/16-14, 1/2-13  
Fine: 10-32, 1/4-28, 5/16-24, 3/8-24, 7/16-20, 1/2-20  
Pipe: 1/8-27 NPT

Part No.	No. of Pcs.	Pkg
5958	39	1 set

## METRIC TAP & DIE SUPER SET

Made from the finest quality tool steel. Carbon steel plug taps, carbon steel hex dies, adjustable tap wrench, t-tap wrench, adjustable die stock, screwdriver, thread gauge, unbreakable plastic case.

### Tap & Die Sizes

Coarse: 3x.50, 4x.7, 5x.80, 6x1.0, 7x1.0, 8x1.25,  
10x1.5, 11x1.5, 12x1.75  
Fine: 4x.75, 5x.90, 8x1.0, 9x1.0, 10x1.25, 12x1.5  
BSP: 1/8x28

Part No.	No. of Pcs.	Pkg.
5959	41	1 set

*High speed steel sets and larger sets available on special request. Call for more information.*

# Hexagon Rethreading Dies

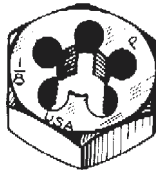

Great for repairing damaged, rusty or painted threads. No special die holder necessary. Almost any wrench can be used. Offered in unified coars (NF), fine (NF) and pipe thread (NPT). Made from carbon steel. Pkg: 1 each.

PART NO.		Size
NC	NF	
6291	-	#4
6292	-	#5
6293	-	#6
6294	-	#8
6295	6296	#10
6297	-	#12
6300	6301	1/4
6302	6303	5/16
6304	6305	3/8
6306	6307	7/16
6308	6309	1/2
6312	6313	9/16
6314	6315	5/8
6316	6317	3/4
6318	6319	7/8
6320	6322	1"
6323	6324	1-1/8
6325	6326	1-1/4
6327	6328	1-3/8
6329	6299	1-1/2

## NPT PIPE SIZES

Part No.	Size
6286	1/8-27 NPT
6287	1/4-18 NPT

*"How poor are they that have not patience! What wound did ever heal but by degrees."*

- William Shakespeare

# Round Adjustable Threading Dies

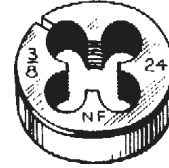

Cuts new threads. Repair damaged, rusty or painted threads. Must be used with special die holders (see next page). Offered in unified coarse (NF) and fine (NF) threads. Made from high speed steel. Pkg: 1 each.

PART NO.		Size	Outside Diameter
NC	NF		
<b>1" O.D.</b>			
50-702	-	#6	1"
50-703	-	#8	1"
50-704	50-719	#10	1"
50-705	-	#12	1"
50-706	50-720	1/4	1"
50-707	50-721	5/16	1"
50-708	50-722	3/8	1"
50-709	50-723	7/16	1"
<b>1-1/2" O.D.</b>			
50-710	50-724	1/4	1-1/2"
50-711	50-725	5/16	1-1/2"
50-712	50-726	3/8	1-1/2"
50-713	50-727	7/16	1-1/2"
50-714	50-728	1/2	1-1/2"
50-715	50-729	9/16	1-1/2"
<b>2" O.D.</b>			
50-716	50-730	5/8	2"
50-717	50-731	3/4	2"
50-718	50-732	7/8	2"

*Metric and pipe thread dies available on special request.*

## Die Stocks



For adjustable round dies only. Maintains positive alignment for accurate threading. Die locks in place with set screw. *For adjustable round dies only.*

Part No.	Die O.D.
10-495	1"
10-492	1-1/2"
10-493	2"



# Universal Rethreading Tools

## Repairs & Reconditions Threads

Puts the thread back onto damaged bolts. Removes dried-on locking agents and sealants. Serves you better than hundreds of dies! Imported.

## Universal Thread Restorers

Adjusts automatically to any thread diameter and pitch. No measuring of thread required! Can be used on right or left hand threads. Applicable to all kinds of threads - both inch and metric. Two hardened steel blades (58RC), guided by the existing thread, re-groove the damaged area. *For anyone who deals with nut and bolts in maintenance, garages, plumbing, construction, agriculture and engineering.*

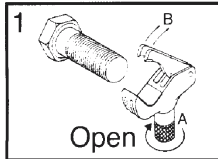

Turn handle (A) to raise blades (B). Place tool over bolt to be repaired.

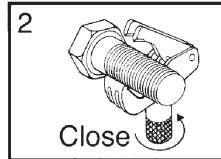

Turn handle (A) to lower blades into grooves of thread and tighten lightly.

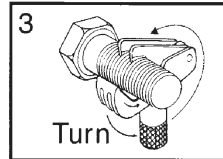

Turn tool in direction of the arrow.



### Small Thread Restorer

Inch O.D. Range: 1/4" - 3/4"

Metric O.D. Range: 6-19 mm

Pkg: 1 each **Part No. 10-555**

Replacement Blades for 10-555  
Part No. 10-555RB Pkg: 2 each



### Large Thread Restorer

Inch O.D. Range: 11/16" - 1-1/2"

Metric O.D. Range: 17 - 38 mm

Pkg: 1 each **Part No. 10-556**

Replacement Blades for 10-556  
Part No. 10-556RB Pkg: 2 each

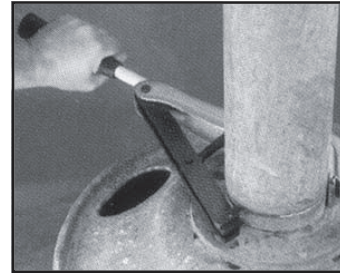

### Giant Thread Restorer

With special extension rod for greater torque.

Inch O.D. Range: 1-1/4" - 5"

Metric O.D. Range: 32 - 128 mm

Pkg: 1 each **Part No. 10-557**

Replacement Blades for 10-557  
Part No. 10-557RB Pkg: 2 each



### Complete Thread Restorer Set

Includes all three thread restorers shown above, plus internal thread cleaner, extension rod, replacement cutters, and case. Pkg: 1 Set

**Part No. 10-558**

## Internal Thread Cleaner

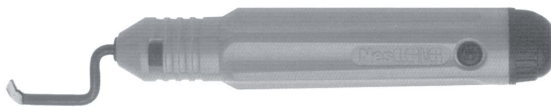

Cleans inch and metric series internal threads from 3/8" (9mm) to 2-11/16" (68mm). Length: 6-1/8. Pkg: 1 each **Part No. 10-559**

Replacement Blades for 10-559  
Part No. 10-559RB Pkg: 1 each

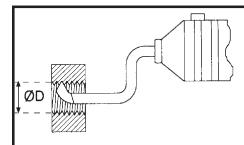



# Cutting Fluids & Coolants



## BruteLube™

Extends the life of cutting tools and provides a superior work-piece finish. Clings to cutting tools for a continuous shield against friction and heat. Excellent fluid for aluminum, stainless steel, and many exotic alloys. *Complies with O.S.H.A. regulations. Does not contain 1,1,1 Trichloroethane. U.S.D.A. authorized.*

Part No.	Size	Pkg
30-243	16 oz. spout-top bottle	12



## Dark Cutting Oil

Cools, speeds metal removal, and produces smooth, clean threads. Will not congeal at 20°F. Excellent for drilling, turning and other metal cutting operations. *Not recommended for lubricating parts.*

Part No.	Size	Pkg
16-301GL	1 gal. Bottle	4



## Metalworking Coolant

Concentrated synthetic coolant dissolves in water for recirculating mist or flood systems in machine shop production applications. Safe to use on all metals and alloys. Contains special corrosion inhibitors to protect finished work from flash rusting. Clear when diluted with water for unobstructed view of the work-piece. *Biodegradable.*

Part No.	Size	Pkg
16-303GL	1 gal. Bottle	4
16-303PL	5 gal. Pail	1



## Foaming Cutting Fluid

Nonflammable formula with active sulfur and an extreme pressure additives keeps cutting tools sharper under higher loads when cutting high alloy steels. Clinging foam will not run or overspray. *Not for aluminum cutting.*

Part Number	Size	Pkg Qty
16-0018B	Net wt. 14 oz. Aerosol	12

## Edge Lube™ Stick Lubricant



Cutting lube in a solid, white, waxy bar. Excellent for vertical or overhead applications. Use on drills, taps, reamers, grinding wheels, sanding belts, hole saws and band saws.

Part No.	Size	Pkg
30-248	Net wt. 13 oz. stick	10

## Tap Magic® Cutting Fluid



Use on Tap Magic on any metal cutting operation. Works on all metals... stainless steels, aluminum, titanium, inconel, brass, magnesium, cobalt, monel, copper, nickel, beryllium, bronze, cast irons, molybdenum and more.

Part No.	Size	Pkg
30-244	4 fl. oz. Spout-top Can	24
30-245	16 fl. oz. Spout-top Can	12
30-246	1 gal. Can	2

## Edge Creme™



Cutting lubricant in a convenient paste form. Use with drills, reamers, annular cutters, hole saws, taps and dies. Excellent for mag drills and vertical applications.

Part No.	Size	Pkg
30-247	Net wt. 11 oz. Tube	10



# Drill Index Cases and Dispensers

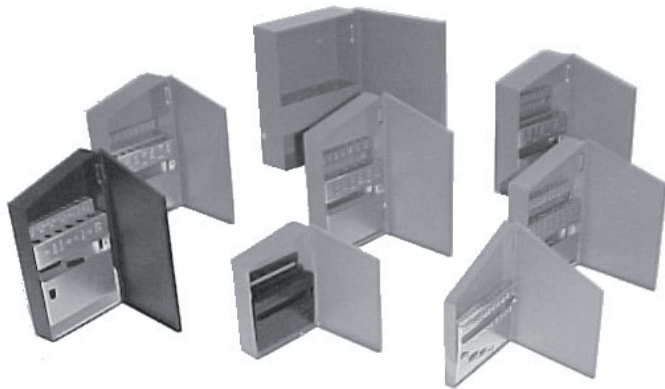

Part No.	Description
5968 ... 13 pc.	Fractional, 1/16-1/4 by 64 <sup>ths</sup>
5970 ... 15 pc.	Fractional, 1/16-1/2 by 32 <sup>nds</sup>
5971 ... 21 pc.	Fractional, 1/16-3/8 by 64 <sup>ths</sup>
6003 ... 29 pc.	Fractional, 1/16-1/2 by 64 <sup>ths</sup>
6004 ... 60 pc.	Wire Gauge, 1-60
6005 ... 26 pc.	Letter Gauge, A-Z
5967 ..... 8 pc.	Fractional S&D, 9/16-1 by 16 <sup>ths</sup>
5966 ... 18 pc.	NC Tap/Drill Index, #6 to 1/2" Taps
5969 ... 18 pc.	NF Tap/Drill Index, #6 to 1/2" Taps

## Drill Dispenser

holds 29 sizes, 1/16" to 1/2" by 64ths. Durable steel, gray enamel finish. Made in U.S.A.

**Part No. 6000**

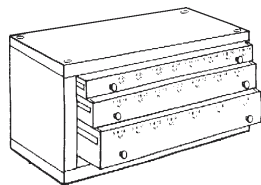

*Also available in metric, wire, letter gauge, and for taps.*

# Drill Grinding Attachment

An inexpensive, precision tool for accurately sharpening the following twist drills sizes:

### DRILL CAPACITY

Fractional ..... 1/8" to 3/4"

Wire gauge ..... 30 to 1

Letter gauge ..... A to Z

Metric ..... 3mm to 19mm

Use with most any type of drill bit. Retains cutting angle accuracy found on many drills. *Does not retain split points.* Must be securely mounted to a bench or surface at the side of a bench grinder with a fine grinding wheel. Instructions included. **Part No. 10-483**

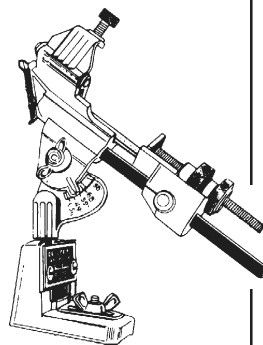

# Professional Drill Sharpener



Never hold up a project for want of a sharp drill! The Drill Doctor® drill sharpener sharpens as easy as you sharpen pencils from 3/32" to 3/4" in under a minute. Sharpens any drill including fractional, metric, number and letter. Sharpens high speed, cobalt and carbide drills. Change conventional standard points to fast-cutting split-point drills.

### DRILL CAPACITY

Fractional ..... 3/32" to 3/4"

Wire gauge ..... 42 to 1

Letter gauge ..... A to Z

Metric ..... 2.5mm to 19mm

The *point style control handle* allows you to sharpen a variety of styles....conventional, split point and masonry points. Change point angles to meet your needs (118° or 135°). Includes two chucks (3/32" to 1/2" and 1/2" to 3/4"). *One diamond cutting wheel included, lasts for approximately 300 sharpenings.* Six foot power cord. Instructions included. Made in U.S.A.

Part No.	Description
9-630 .....	Drill Doctor 750 Pro Sharpener
9-630W .....	Replacement Diamond Wheels
9-630SC .....	Molded Storage Case

# Thread Restoring Files

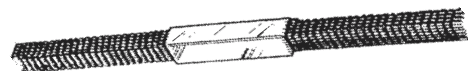

Restore battered, rusted and corroded threads quickly. Thread sizes marked on file. Size: 7/16 square x 8 1/2". Made in U.S.A.

Part No.	Threads Per Inch
21-427 .....	11, 12, 13, 14, 16, 18, 20, & 24
21-428 .....	9, 10, 12, 16, 20, 27, 28, & 32

# Hack Saw Frames & Blades

## High-Tension Heavy Duty Frame



**ERGONOMIC GRIP DESIGN** provides extra comfort and maximum finger protection.

**TENSIONING HANDLE** for extra torque, for maximum tension and superior cutting performance.

**ALLOY STEEL SUPPORT BEAM** increases frame strength and durability.

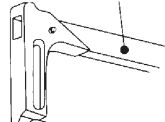
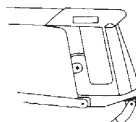
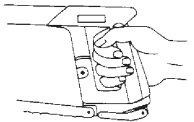

**LOCKING SCREW DESIGN** secures spare blades in tube or locks protruding blade for "jab" sawing.

**MULTIPLE PIN LOCATIONS** allows standard (90°) or angled (45°) blade mounting for standard or flush-cut applications.

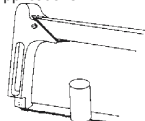
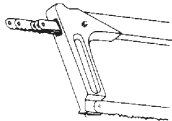

Withstands tension in excess of 60,000psi! Made in U.S.A. Accepts 12" long blades. 20/24 TPI variable tooth bimetal blade (1) included. **Part No. 1629**

## Light Weight High-Tension Frame

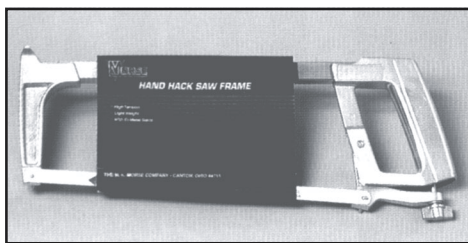

Lightweight, rigid frame design. Handle and end pieces are tough, die-cast aluminum. Blade can be set at 55° angle for flush cutting. Includes 12"-24TPI bimetal saw blade. Storage compartment for spare blades. Can be used as a "jab" saw. **Part No. 1640**

## Adjustable Frame



Standard duty, has an adjustable frame for both 10" and 12" blade lengths. Enclosed handle. Depth of cut is 3-3/4". Includes 24TPI blade. **Part No. 1635**

## Bimetal Hack Saw Blades

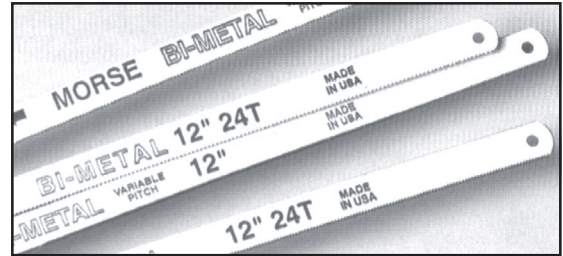

**SAFE TO USE • FLEXIBLE • WILL NOT SHATTER**  
Bimetal blades offer a super-sharp high-speed steel cutting edge, electron beam welded to a flexible alloy back. Allows straight cuts and long life in high tension frames and greatest possible user safety. To select proper tooth spacing, 3 teeth minimum (6 to 12 teeth optimum) must be in contact with the work at all times. Tooth hardness: Rc 65-67 for increased heat and wear resistance and long life. **NEW VARIABLE PITCH** option allows fast and efficient cutting in a wider range of materials than standard tooth blades. That lets you stock fewer blades and saves you time and money!

Size	TPI	Part No.	Pkg Qty
<b>STANDARD TOOTH</b>			
1/2 x 12"	18	1630	10 ea
'Case of 100'		1630C	1 cs
1/2 x 12"	24	1631	10 ea
'Case of 100'		1631C	1 cs
1/2 x 12"	32	1632	10 ea
'Case of 100'		1632C	1 cs
<b>VARIABLE TOOTH</b>			
1/2 x 12"	14/18	1627	10
'Case of 100'		1627C	1 cs
1/2 x 12"	20/24	1628	10
'Case of 100'		1628C	1 cs

## Power Hack Saw Blades

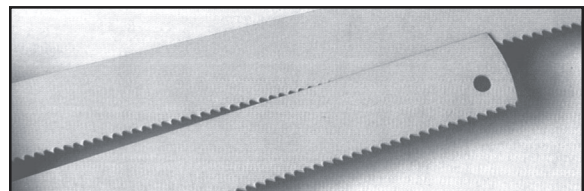

Bimetal power blades, consisting of a high-speed cutting edge welded to an alloy back. Built for long lasting service under average shop cutting conditions.

Size	TPI	Part No.	Pkg Qty
1" x 12"	14	1633	10
1" x 14"	14	1634	10



# Bimetal Reciprocating Saw Blades

(Saw-zall style blades)

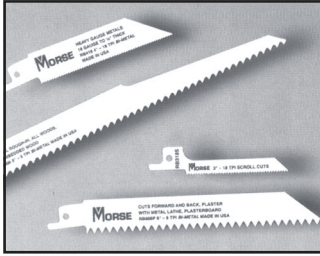

Designed to fit all popular reciprocating machines that take 1/2" shank blades. High speed steel cutting edge welded to a flexible alloy steel back. Faster cutting with sharper, harder teeth and extra strength shank. Bimetal steel reduces breakage and last longer than conventional carbon and high speed blades. Cuts steel, stainless steel, nail-embedded wood, hardwood flooring, reinforcing bar, conduit, cast iron, and pipe. Made in the U.S.A.



## METAL CUTTING 1/8" THICK & ABOVE

1/2" Shank Bimetal Blades for heavy gauge metals 1/8" thick and above. Barstock & Angles.  
Blade thickness: .035". **Sold in full packages only.**

Part No.	Length	Width	Teeth Per Inch	Pkg Qty
21-310•	4"	3/4"	14T	5
21-310B	4"	3/4"	14T	50
21-311•	6"	3/4"	14T	5
21-311B	6"	3/4"	14T	50



## NAIL EMBEDDED WOOD CUTTING / PLASTER

1/2" Shank Bimetal Blades for fast wood cutting & general roughing-in work. Blade thickness: .050". **Sold in full packages only.**

Part No.	Length	Width	Teeth Per Inch	Pkg Qty
21-316•	6"	3/4"	6T	5
21-316B	6"	3/4"	6T	50
21-317•	12"	3/4"	6T	5
21-317B	12"	3/4"	6T	50

## METAL CUTTING 18 GAUGE TO 1/8" THICK

1/2" Shank Bimetal Blades for heavy gauge metals of 18 gauge to 1/8" thick. Conduit, pipe, channels and tubing.  
Blade thickness: .035". **Sold in full packages only.**

Part No.	Length	Width	Teeth Per Inch	Pkg Qty
21-312•	4"	3/4"	18T	5
21-312B	4"	3/4"	18T	50
21-313•	6"	3/4"	18T	5
21-313B	6"	3/4"	18T	50

## "VARIABLE TOOTH"

### WOOD CUTTING / LIGHT METAL CUTTING

1/2" Shank Bimetal Blades for all wood, composition materials, plastics, nail embedded wood, cast aluminum, light gauge metals. Blade thickness: .035"  
**Sold in full packages only.**

Part No.	Length	Width	Teeth Per Inch	Pkg Qty
21-318•	8"	3/4"	10/14T	5
21-318B	8"	3/4"	10/14T	50

## METAL CUTTING 18 GAUGE\* & UNDER

1/2" Shank Bimetal Blades for light gauge tubing and sheet metal 18 gauge thick and under.  
Blade thickness: .035". **Sold in full packages only.**

Part No.	Length	Width	Teeth Per Inch	Pkg Qty
21-314•	4"	3/4"	24T	5
21-314B	4"	3/4"	24T	50
21-315•	6"	3/4"	24T	5
21-315B	6"	3/4"	24T	50



**RECIPROCATING SAW BLADE ASSORTMENT**  
6 SIZES IN A LARGE STEEL DRAWER.  
**PART NO. 16-5506**

Note: Part numbers marked with a bullet (•) included in assortment no. 16-5506.

# Sabre/Jig Saw Blades

1/4" universal shank. Extra tough, sharp teeth.  
Pkg: 5 each (no broken packages)



## BIMETAL

### METAL CUTTING 1/8" THICK & ABOVE

Bimetal Blades for light gauge metals, fiberglass, hard rubber, nail-embedded woods. *Blade thickness: .035"*

Part No.	Length	Width	Teeth Per Inch
21-319	3-5/8"	3/8"	14T

### METAL CUTTING 18 GAUGE\* & UNDER

Bimetal Blades for light gauge metals 18 gauge thick and under. Trim, tubing, etc. *Blade thickness: .035"*

Part No.	Length	Width	Teeth Per Inch
21-320	2-3/4"	3/8"	18T

### FERROUS & NON-FERROUS METAL CUTTING UP TO 1/8" THICK

Bimetal Blades for metals up to 1/8" thick. *Blade thickness: .035"*

Part No.	Length	Width	Teeth Per Inch
21-321	2-3/4"	3/8"	24T

## New! Step-Down Butt Connectors



In stock at MPI! See catalog page 153



## HIGH SPEED STEEL

### FERROUS METAL CUTTING 1/16" TO 3/16"

**THICK, NONFERROUS METALS TO 1/8" THICK**  
*Blade thickness: .032"*

Part No.	Length	Width	Teeth Per Inch
21-322	2-3/4"	5/16"	24T



## CARBON STEEL

### WOOD CUTTING 1/4" TO 1" THICK

Scroll cutting wood, plywood, plastics. Smooth cuts. *Blade thickness: .050"*

Part No.	Length	Width	Teeth Per Inch
21-323	2-3/4"	1/4"	12T

## Foaming Cutting Fluid



Nonflammable formula with active sulfur and an extreme pressure additives keeps cutting tools sharper under higher loads when cutting high alloy steels. Clinging foam will not run or overspray.

Part Number	Size	Pkg Qty
16-0018B	Net wt. 14 oz. Aerosol	12



# Band Saw Blades

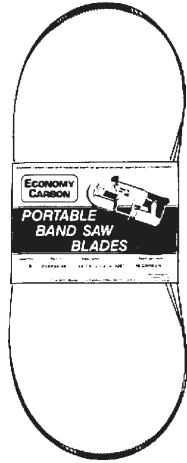

## Carbon Steel Band Saw Blades

Low Carbon Heat Treated Steel. Accepts heavy feed pressure and blade tension. Used in production for softer, easy feed materials such as plastics, wood, and machineable metals. Thickness: .025". Raker set\*.

Part No.	Length	Width	Teeth Per In.	Pkg Qty
6700	44-7/8"	1/2"	14T	3
6701	64-1/2"	1/2"	14T	2

## Bimetal Band Saw Blades

Fast cutting, high-speed steel edge welded to a flexible alloy back. Used for cutting hard metals. Resists heat and shock and can be operated at speeds up to ten times faster than regular carbon blades. The quality of Bimetal Band Saw Blades reduces blade costs per cut by increasing cutting rate and blade life.

Thickness: .035" • Raker set\* • Pkg: 2 each

Part No.	Length	Width	Teeth Per In.	Pkg Qty
6702	44-7/8"	1/2"	14T	3
6703	64-1/2"	1/2"	14T	2



\***RAKER SET** One tooth is set to the left, one tooth to the right, and one tooth (the Raker) is unset. This style is used on most production cutting jobs.



# Custom-Made Band Saw Blades

Cut-to-Length and welded to your specifications. Any length and material available. When ordering custom blades please specify the following information:

1. TYPE OF MATERIAL
2. BLADE WIDTH
3. BLADE LENGTH
4. TEETH PER INCH

### MATERIAL SELECTION

**Carbon-Hardback** - for economic production and general purpose cutting of low alloy and nonferrous steels.

**M42 Bimetal** - lasts up to ten times longer than carbon blades. Fast cutting. Use for a wider range of materials, tubing, solids and forms. Special cutting edge contains 8% cobalt.

**Wood Cutting** - flexible blade has hook teeth designed to quickly rip and crosscut wood of all types.

### WIDTH SELECTION

MATERIAL	WIDTH
Carbon hardback	1/8" to 2"
M42 Bimetal	1/4" to 1-1/2"
Wood Cutting	1/4, 3/8, 1/2, 3/4, 1"

### TEETH PER INCH SELECTION

MATERIAL	THREADS PER INCH
Carbon hardback (raker set)	6, 8, 10, 14, 18, 24, 32
M42 Bimetal (raker set)	6, 10, 14, 18
Wood cutting (hook tooth)	3, 4

### DETERMINING BLADE LENGTH

Just use one of the three following methods to determine the blade length. 1.) Cut an old blade and measure the length from end to end. 2.) Apply masking tape around a blade and overlap the ends. With a knife, cut tape across the overlapped area, then remove tape and measure length. 3.) Specify saw make and model number when ordering.

**Note:** Custom-made blades are not returnable unless an error was made on our part.

# Bimetal Hole Saws with "Built-in" Arbors



No more lost arbors! Permanently attached arbors in all sizes saves in tool costs and setup time. Variable pitch (4/6T positive rake) lasts up to 3 times longer than 6 pitch saws. Variable pitch design cuts up to 45% faster than standard 6 pitch saws. High-speed bimetal M3 tooth design cuts pipe, steel, cast iron, plastic and wood. Hex arbor size: 7/16". Cutting depth: 1-3/8".

Part No.	Diameter (Inch)	Diameter (MM)
6600	9/16	14
6601	5/8	16
6602	11/16	17
6603	3/4	19
6604	13/16	21
6605	7/8	22
6606	15/16	24
6607	1"	25
6608	1-1/16	27
6609	1-1/8	29
6610	1-3/16	30
6611	1-1/4	32
6612	1-5/16	33
6613	1-3/8	35
6614	1-7/16	37
6615	1-1/2	38
6616	1-9/16	40
6617	1-5/8	41
6618	1-11/16	43
6619	1-3/4	44
6620	1-13/16	46
6621	1-7/8	48
6622	2"	51
6623	2-1/16	52
6624	2-1/8	54
6625	2-1/4	57
6626	2-3/8	60
6627	2-1/2	64
6628	2-5/8	67
6629	2-3/4	70
6630	2-7/8	73
6631	3"	76
6632	3-1/8	79
6633	3-1/4	83
6634	3-1/2	89
6635	3-5/8	92
6636	3-3/4	95
6637	3-7/8	98
6638	4"	102
6639	4-1/8	105
6640	4-1/4	108
6641	4-3/8	111
6642	4-1/2	114
6643	4-3/4	121
6644	5"	127
6645	5-1/2	140
6646	6"	152

- Pilot Drill not included (see next page).

# Traditional Bimetal Hole Saws

(Separate Arbors)

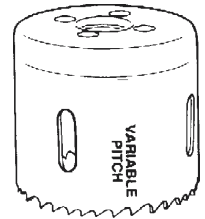

High-speed bimetal M3 tooth design. Variable pitch (4/6T positive rake) lasts up to 3 times longer than ordinary 6 pitch saws. Variable pitch design can reduce labor costs and tool costs in a wide range of applications. Cuts up to 45% faster than 6 pitch saws. Cuts pipe, steel, cast iron, plastic and wood. Arbor and Pilot Drill not included. Cutting depth: 1-3/8".

Part No.	Diameter (Inch)	Diameter (MM)
6650	9/16	14
6651	5/8	16
6652	11/16	17
6653	3/4	19
6654	13/16	21
6655	7/8	22
6656	15/16	24
6657	1"	25
6658	1-1/16	27
6659	1-1/8	29
6660	1-3/16	30
6661	1-1/4	32
6662	1-5/16	33
6663	1-3/8	35
6664	1-7/16	37
6665	1-1/2	38
6666	1-9/16	40
6667	1-5/8	41
6668	1-11/16	43
6669	1-3/4	44
6670	1-13/16	46
6671	1-7/8	48
6672	2"	51
6673	2-1/16	52
6674	2-1/8	54
6675	2-1/4	57
6676	2-3/8	60
6677	2-1/2	64
6678	2-5/8	67
6679	2-3/4	70
6680	2-7/8	73
6681	3"	76
6682	3-1/8	79
6683	3-1/4	83
6684	3-1/2	89
6685	3-5/8	92
6686	3-3/4	95
6687	3-7/8	98
6688	4"	102
6689	4-1/8	105
6690	4-1/4	108
6691	4-3/8	111
6692	4-1/2	114
6693	4-3/4	121
6694	5"	127
6695	5-1/2	140
6696	6"	152

9/16 to 1-3/16 diameter have 1/2-20 threaded arbor hole.

1-1/4 to 6" diameter have 5/8-18 threaded arbor hole.



# Hole Saw Sets

## Bimetal Hole Saw Set with Built-in Arbors

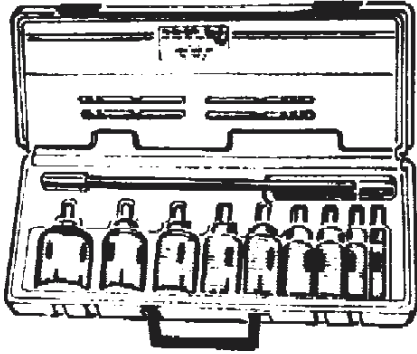

No more lost arbors! Permanently attached arbors saves in tool costs and set-up time. Variable pitch (4/6 tooth positive rake). Lasts up to 3 times longer than 6 pitch saws! Sizes: 3/4, 7/8, 1-1/8, 1-3/8, 1-1/2, 1-3/4, 2-1/4, 2-1/2 holes saws. 4 pilot drills. 1 screwdriver. 1 - 12" extension. Sturdy plastic carrying case. **Part no. 6647**

## Traditional Bimetal Hole Saw Set

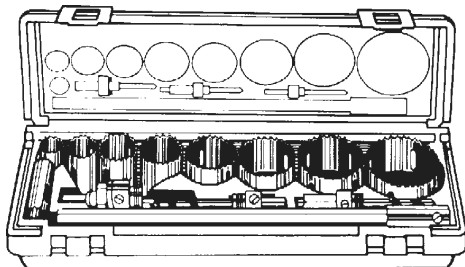

Variable pitch (4/6t positive rake). Lasts up to 3 times longer than 6 pitch saws. Sizes: 3/4, 7/8, 1-1/8, 1-3/8, 1-1/2, 1-3/4, 2-1/4, 2-1/2 holes saws. 3 arbors, 3 drills, 1 - 12" extension. Sturdy plastic carrying case. **Part no. 6648**

**Red Hot Deals!**

Check out our current specials and new items on our website at <http://www.mpi-online.com>

# Hole Saw Accessories



## Hole Saw Arbors

Arbor w/Drill Part No.	For Saws	Drill Part No.	Arbor Thread Size	Drill Chuck Size
<b>1/4" ROUND SHANK</b>				
6704	9/16 to 1-3/16	6709	1/2-20	1/4-1/2
<b>1/4" HEX SHANK</b>				
6705	9/16 to 1-3/16	6710	1/2-20	1/4-1/2
<b>7/16" HEX SHANK</b>				
6706	9/16 to 1-3/16	6709	1/2-20	1/2
<b>7/16" HEX SHANK</b>				
6707	1-1/4 to 6"	6710	5/8-18	1/2

## Hole Saw Pilot Drills

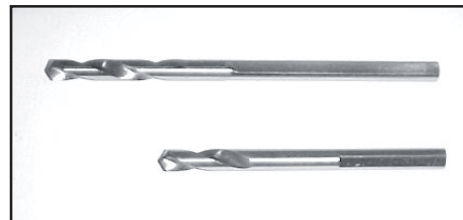

Fits both traditional and built-in style arbors.

Part No.	Size	Pkg Qty
6709	1/4 x 4-1/2, 3 flat sides	1
6710	1/4 x 3", 1 flat side	1

## 12" Hole Saw Extension



Fits 7/16" hex shank hole saw arbors.

Part No.	Length	Drill Chuck Size
6708	12"	1/2



# Depressed Center Grinding Wheels

## Aluminum Oxide Metal Grinding

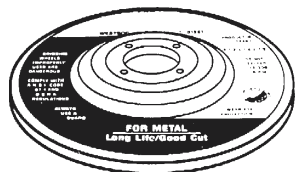

Fast-cutting aluminum oxide grain for use on mild & harder ferrous metals with high metal removal rate. Use 1/8" thick for cut-off, pipe notching and occasional grinding. Use 1/4" thick for heavy duty welds and surface grinding.

### Flat - Type 27 (without hub)

*Pkg. Qty. - 25 each*

Part No.	Dia.	Thick-ness	Arbor	Max. RPM*	Spec.
6-444	3"	1/8	3/8	19,000	A30
6-445	4"	1/8	3/8	15,000	A30
6-446	4"	1/8	5/8	15,000	A30
6-447	4½"	1/8	7/8	15,000	A30
6-470	7"	1/8	7/8	8,500	A24
<hr/>					
6-342	3"	1/4	3/8	20,000	A30
6-343	4"	1/4	3/8	15,000	A30
6-381	4"	1/4	5/8	15,000	A30
6-035	4½"	1/4	7/8	13,300	A30
6-038A	7"	1/4	7/8	8,500	A24
6-039A	9"	1/4	7/8	6,500	A24



### Flat - Type 27 (with 5/8-11 Hub)

*Pkg. Qty. - 10 each*

6-476	4½"	1/4	5/8-11	13,300	A30
6-344	7"	1/8	5/8-11	8,500	A24
6-038	7"	1/4	5/8-11	8,500	A24
6-039	9"	1/4	5/8-11	6,500	A24

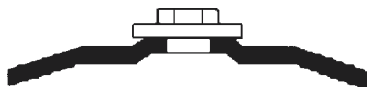

### Saucer - Type 28 (with 5/8-11 Hub)

*Pkg. Qty. - 10 each*

6-036	7"	1/4	5/8-11	8500	A20
6-037	9"	1/4	5/8-11	6500	A20

## Zirconia Metal Grinding

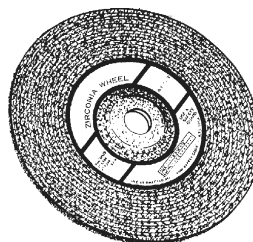

Use on titanium, mild steels, and most hardened metals. Excellent for grinding hard-surface welds on buckets and plows. Zirconium costs much less than natural diamonds and is one of the hardest man-made materials known. Out-lasts aluminum oxide wheels 5 to 1. Cuts costs, reduce expensive down-time changing wheels. Zirconia wheels stay sharp as new surfaces constantly replace worn edges, for faster and cleaner grinding.

### Flat - Type 27

Part No.	Dia.	Thick-ness	Arbor	Max. RPM*	Spec.	Pkg Qty
6-448	4½"	1/4	7/8	13,300	Z24T	25
6-355	7"	1/4	5/8-11	8,500	Z24T	25
6-356	9"	1/4	5/8-11	6,500	Z24T	20

*• with Hub*

## Silicone Carbide Masonry Grinding

Use on medium to soft non-metallic materials.

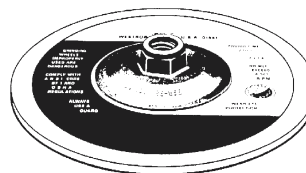

### Flat - Type 27 with Hub

*Pkg. Qty. - 10 each*

Part No.	Dia.	Thick-ness	Arbor	Max. RPM*	Spec.
6-040	7"	1/4	5/8-11	8,500	C16

**SAVE WHEN YOU  
BUY IN QUANTITY!**

*\*Complies with American National Standards Institute (ANSI) codes.*



# Depressed Center Grinding Wheels

## The Flex Wheel

Combines the advantages of depressed center grinding wheels and resin fibre discs.

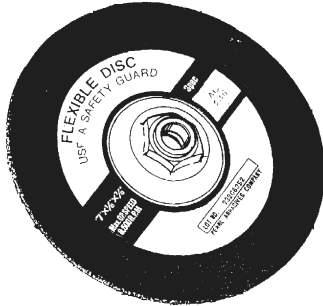

**Last Longer** - The flex wheel puts more grinding surface on the job, grinds faster, outwears five or six fibre discs, wears more evenly.

**Does Better Work** - Flexibility means a better fit between wheel and job, results in a smoother finish and faster work.

**Reduces Vibration** - Flexibility means less vibration, reduces operator fatigue, improves accuracy.

**Stronger** - The flex wheel is double reinforced with a top layer of non-woven fabric and an internal layer of reinforcing cloth.

**Reduces Dust** - Superior bonding in the flex wheel reduces wear and dust.

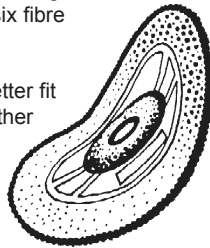

*AC36 Grit*

Part No.	Diam.	Thick -ness	Arbor	Max. RPM*	Pkg Qty	
6-454	4"	1/8	5/8	13,700	20	
6-455*	4"	Plastic Back-up Pad for 6-454				1
6-456	4½"	1/8	7/8	13,700	25	
6-457*	4½"	Plastic Back-up Pad for 6-452				1
6-345	7"	1/8	7/8	8500	10	
6-380*	7"	Plastic Back-up Pad for 6-345				1
6-350	7"	1/8	5/8-11	8500	25	

•One Plastic Back-up Pad free with each full package order of Flex Wheels.

**WARNING:** Do not use flex wheels on high speed air sanders.

## Flaring Cupstones

Aluminum oxide grain. Grinds welds fast. Use on mild or harder ferrous metals. Resin bonded with a full steel back.

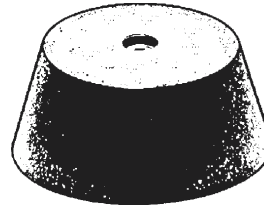

### For Steel

*Pkg. Qty. - 5 each*

Part No.	Large End Dia.	Thick -ness	Arbor	Max. RPM*	Spec.
6-215	5"	2"	5/8-11	7,258	A16
6-216	6"	2"	5/8-11	6,040	A16

## Silicone Carbide Aluminum Grinding

For grinding aluminum, aluminum alloys, & cupro nickel weldments. Extremely cool cutting and will not load due to special wax treatment that dissipates heats.

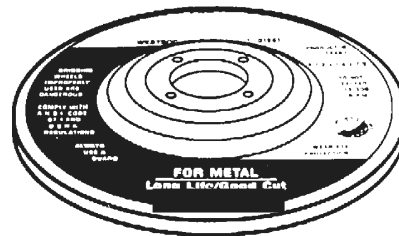

### Flat - Type 27

*Pkg. Qty. - 25 each*

Part No.	Dia.	Thick -ness	Arbor	Max. RPM*	Spec.	Pkg Qty
6-450	4"	1/4"	5/8"	15,000	A24	25
6-451	4½"	1/4"	7/8"	13,300	A36	10
6-452	7"	1/4"	5/8-11	8,500	A36	10
6-453	7"	1/4"	7/8"	8,500	A36	25

•With Hub

\*Complies with American National Standards Institute (ANSI) codes.

**SAVE WHEN YOU BUY IN QUANTITY!**

# Cut-Off Wheels

## For Circular Saws: 6-8"

Fast cutting with minimum burr. Works equally efficient on steel, iron, tubing, conduit, structural shapes, sheets.

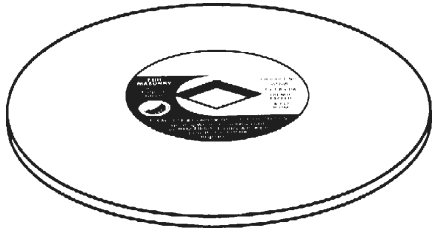

### Reinforced Type 1

Includes diamond arbor adapter with 5/8" hole

Part No.	Diam.	Thick-ness	Max. RPM*	Pkg Qty
<b>GENERAL PURPOSE METAL CUTTING</b>				
6-357	6"	1/8	10,186	10
6-358	7"	1/8	8,732	10
6-360	8"	1/8	7,640	10
<b>STAINLESS STEEL CUTTING</b>				
6-009	7"	3/32	8,732	10
<b>MASONRY CUTTING</b>				
6-359	7"	1/8	8,732	10
6-361	8"	1/8	7,640	10
<b>ALUMINUM CUTTING</b>				
6-458	7"	1/8	6,800	25



### DIAMOND ARBOR ADAPTERS

973	Diamond to 1/2" hole	10
974	Diamond to 5/8" hole	10

# Cut-Off Wheels

## For Die Grinders: 3-4"

Use on die grinders, small pencil grinders and some end grinders with straight or flexible shafts. For a variety of metal cutting, grinding, blending and smoothing operations on ferrous metals, cast iron, steel, stainless steel, alloys, tool steel, and exotics.

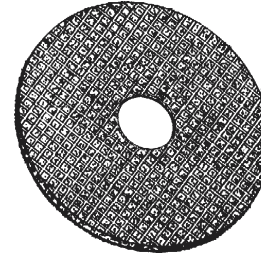

### Reinforced Type 1 - Metal Cutting

Part No.	Diam.	Thick-ness	Arbor	Max. RPM*	Spec.
<b>GENERAL PURPOSE METAL CUTTING Pkg: 50 each</b>					
6-459	3"	1/32	1/4	25,450	A60
6-007	3"	1/16	1/4	25,450	A36
6-008	3"	1/32	3/8	25,450	A60
6-480	3"	1/16	3/8	20,370	A36
6-375	3"	1/8	3/8	25,450	A36
6-460	4"	1/32	3/8	19,000	A60
6-377	4"	1/16	3/8	19,000	A36
6-378	4"	1/8	3/8	19,000	A36

### STAINLESS STEEL CUTTING Pkg: 50 each

6-481	3"	1/16	3/8	20,370	NZ30
-------	----	------	-----	--------	------

### ALUMINUM CUTTING Pkg: 25 each

6-482	3"	1/8	3/8	20,370	CA30
-------	----	-----	-----	--------	------



### Quick Change Drive Arbors

Quickly adapts small diameter Cut-Off Wheels and Wire Brushes without removing arbor from tool.

Part No.	Arbor Diam.	Stem Diam.	Max. RPM*
6-104	1/4"	1/4"	20,000
6-105	3/8"	1/4"	20,000
6-106	1/2"	1/4"	20,000



### Low Profile Drive Arbors

Inner locking nut. Low profile shank adapter for use with Cut-Off Wheels and Wire Brushes.

Part No.	Arbor Diam.	Stem Diam.	Max. RPM*
6-109	3/8"	1/4"	20,000
6-110	1/2"	1/4"	20,000

\*Complies with American National Standards Institute (ANSI) codes.

# Large Abrasive Cut-Off Wheels

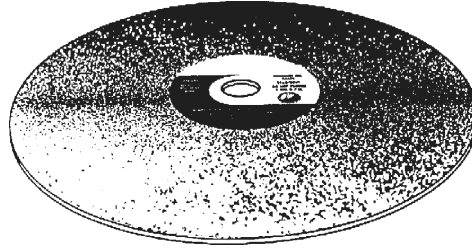

## Stationary and Chop Saws 12-14"

Use where material to be cut is securely held by vise or clamp fixture and the wheel is drawn through the material.

*Caution:*

*These wheels must never be used on a portable saw.*

### Type 1 - Metal Cutting

Part No.	Thick Dia.	Arbor	Max. RPM*	Spec.	Pkg Qty
6-363	12"	1/8"	5092	A36	10
6-364A	14"	3/32"	4366	A46T	10
6-364	14"	5/32"	4366	A24	10

•Use 3/32" thick on smaller, low horsepower chop saws.

## Portable Gas & Electric Saws 12-14"

These saws have spindle RPM's in excess of stationary saws. Used in steel building erection, construction and salvage.

### Reinforced - Type 1

Part No.	Thick Dia.	Arbor	Max. RPM*	Spec.	Pkg Qty
<b>FOR METAL</b>					
6-365	12"	1/8"	6,000	A20	10
6-367	14"	1/8"	5,400	A20	10
<b>FOR CONCRETE</b>					
6-366	12"	1/8"	6,000	C20	10
6-368	14"	1/8"	5,400	C20	10

## Walk-Behind Street Saws 12-14" 18 Horse Power and Under

### Type 1 - Cured Concrete/Asphalt

For long life with good cut on "cured concrete" (concrete cured over 48 hours) or asphalt.

ARBOR: 1" WPH (With Pin Hole)

Part No.	Thick Dia.	Arbor	Max. RPM*	Spec.	Pkg Qty
6-369	12"	3/16"	5092	C16	10
6-461	14"	3/16"	4366	C16	5

### Type 1 - Green Concrete

For long life with good cut on "green concrete" (concrete cured less than 48 hours)

ARBOR: 1" WPH (With Pin Hole)

Part No.	Thick Dia.	Arbor	Max. RPM*	Spec.	Pkg Qty
6-373	14"	3/16"	4366	C16	5

## Cut-Off Wheel Adapters



Plastic bushings for use on large cut-off wheels.

Part No.	Size	Pkg Qty
993	1" to 5/8"	10
994	1" to 7/8"	10
995	1" to 20 mm	10

\*Complies with American National Standards Institute (ANSI) codes.

# Mounted Points

Designed for use in high speed die grinders. These precision made mounted points are used for a variety of grinding jobs ranging from the fine tool and die work to weld grinding and blending. (Illustrations are not actual size)

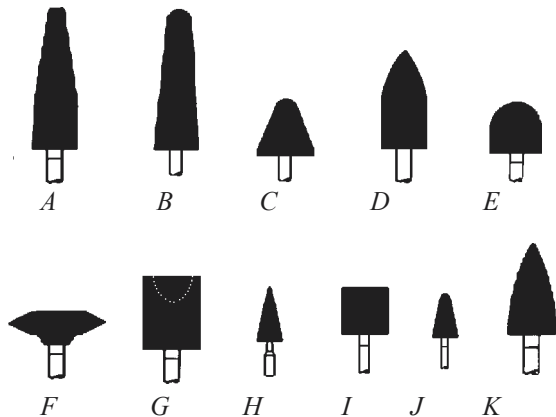

## 1/8" Shank

Part No.	Fig.	Trade No.	Dia.	Thick -ness	Max. RPM*
6-300	D	B42	1/2	3/4	33,750
6-301	J	B52	3/8	3/4	45,370
6-302	H	B53	1/4	5/8	60,000
6-303	G	B131	1/2	1/2	34,500
6-304	G	B132	3/8	1/2	45,370
6-305	I	W163	1/4	1/2	60,000
6-306	I	W164	1/4	3/4	45,900
6-307	I	W175	3/8	3/8	54,000
6-308	I	W176	3/8	1/2	45,370

## 1/4" Shank

Part No.	Fig.	Trade No.	Dia.	Thick -ness	Max. RPM*
6-309	A	A1	3/4	2-1/2	19,800
6-310	B	A3	7/8	2-3/4	16,100
6-311	C	A4	1-1/4	1-1/4	30,560
6-312	C	A5	1-1/4	1-1/8	45,000
6-313	D	A11	13/16	1-1/4	19,860
6-314	K	A12	11/16	1-1/4	48,000
6-315	E	A21	1"	1"	34,500
6-316	F	A36	1-5/8	3/8	23,520
6-317	G	A38	1"	1"	34,500
6-318	I	W185	1/2	1/2	61,500
6-319	I	W215	1"	1/8	38,200
6-320	I	W220	1"	1"	25,500



# Bench Grinding Wheels

Each and every wheel is trued, balanced and speed tested to insure fast cutting, long lasting performance on a variety of metals.



## Aluminum Oxide

For general purpose ferrous metal cutting.

Diam.	Thick -ness	Arbor	Max. RPM*	PART NUMBER		
				Coarse	Med.	Fine
6"	3/4	1" <sup>1</sup>	4100	6-017	6-016	6-015
6"	1"	1" <sup>1</sup>	4100	6-020	6-019	6-018
7"	1"	1" <sup>1</sup>	3600	6-023	6-022	6-021
8"	1"	1" <sup>2</sup>	3600	6-026	6-025	6-024
10"	1"	1 1/4" <sup>3</sup>	2400	6-202	6-201	6-200
10"	1 1/2"	1 1/4" <sup>3</sup>	2400	6-205	6-204	6-203
12"	1-1/2	1-1/2" <sup>4</sup>	2069	6-208	6-207	6-206
12"	2"	1-1/2" <sup>4</sup>	2069	6-211	6-210	6-209
14"	2"	1-1/2" <sup>4</sup>	1773	6-214	6-213	6-212

<sup>1</sup> ...1/2", 5/8", & 3/4" bushings supplied

<sup>2</sup> ...5/8" & 3/4" bushings supplied

<sup>3</sup> ...3/4" & 1" bushings supplied

<sup>4</sup> ...1" & 1 1/4" bushings supplied

## Silicon Carbide

For Carbide Materials, Glass, Fiberglass

Diam.	Thick -ness	Arbor	Max. RPM*	Gen. Purpose	
				80 Grit	Finishing 120 Grit
6"	1"	1"	4138	6-032	6-031
7"	1"	1"	3600	6-033	-
8"	1"	1"	3600	6-034	-

1/2, 5/8, & 3/4 bushings supplied with each wheel

## Plastic Grinding Wheel Bushings



Telescopic adapter fits 1" wide bench grinding wheels.

Part No.	Size	Pkg
971	1" to 3/4", 5/8", 1/2"	5

\*Complies with American National Standards Institute (ANSI) codes.



# Grinding Wheel Dressers



Dress all kinds of grinding wheels quickly, exposing sharp new grains. Gives wheels a fresh, unloaded surface. Features hardened, high carbon steel multipiece cutters. Hooded handle helps protect you from flying abrasive.

Part Size	For Wheel Size	Trade No.	Repl. Cutters
7077	UP TO 10"	#0	7078*
7079	10" - 16"	#1	7080*

\* Replacement Cutters are packaged 10 each

# Emery Cloth Sheets

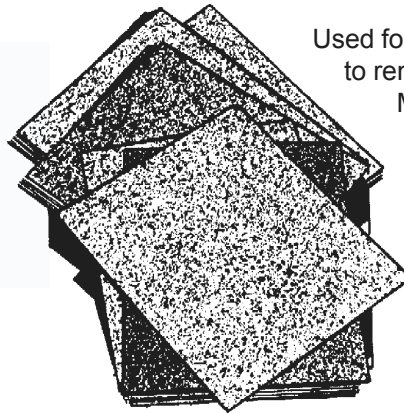

Used for light metal sanding to remove rust and scale. May be used dry or with oil.

**9" x 11" SHEETS**

Part No.	Grit	Pkg. Qty.
6-073	180 fine	50 sheets
6-074	120 medium	50 sheets
6-075	80 coarse	50 sheets

# Crocus Cloth

Fine 1500 grit cloth polishes metals and copper pipe. 9" x 11" sheets. Pkg: 50 sheets. **Part No. 6-077**

# Silicon Carbide Screen-Bak

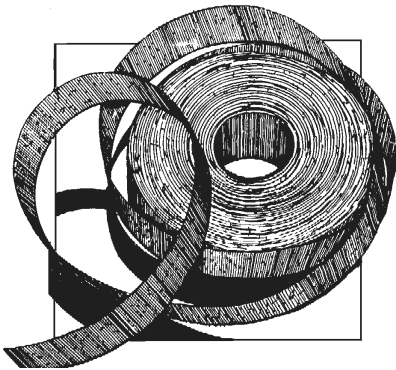

Screen-Bak woven fabric is **silicone carbide coated** on both sides. The special open mesh resists clogging even under the hardest use. Flexible and can easily be folded for use as a pad. Tears easily with clean straight edges. Won't disintegrate when wet. Can be used wet or dry. Uses: sanding painted surfaces, metal, wood, and plaster. **Roll size 1½" x 25 yards**

Part No.	Grit	Pkg
6-087SC	180 fine	1 Roll
6-088SC	120 medium	1 Roll
6-089SC	80 coarse	1 Roll

# Cloth Shop Rolls

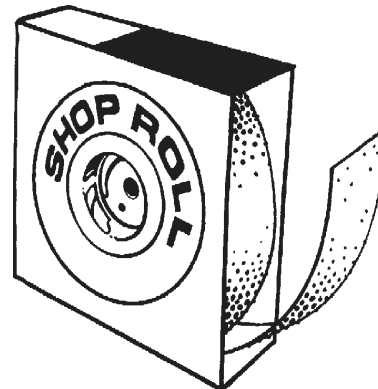

Aluminum oxide abrasive over flexible cloth backing. Ideal for light finishing of small parts and contoured surfaces. Easy to tear into convenient lengths yet will not shred. **Roll size: 1½" x 50 yards**

Part No.	Grit	Pkg
6-078	400	1 Roll
6-079	320	1 Roll
6-080	240	1 Roll
6-081	180	1 Roll
6-082	150	1 Roll
6-083	120	1 Roll
6-084	100	1 Roll
6-085	80	1 Roll
6-086	60	1 Roll

# TRIM-KUT® Discs

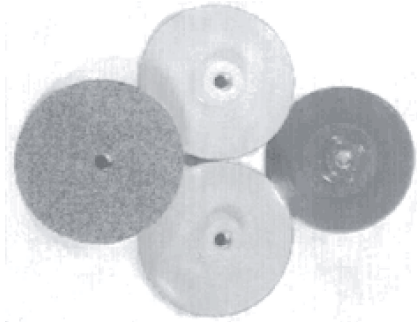

## RENEWABLE EDGE

Use for edge blending, chamfering, deburring, paint preparation, surface finishing, light weld and stock removal. Tough, trimmable nylon composite backer conforms to uneven surfaces, run cooler. Aluminum oxide abrasive grain fused to backer eliminates the need for back-up pad. Use on metal, wood, fiberglass. Excellent for autobody and boat repair shops.

**ARBOR SIZE: 5/16-18 • PKG: 25 EA**

Part No.	Diameter	Grit	Color	Max. RPM*
6-438	3"	36, coarse	Red	28,000
6-439	3"	60, medium	Orange	28,000
6-440	3"	120, fine	Green	28,000

**STORAGE;** If stored for extended periods of time, Trim-Kut Discs should be sealed in plastic at 50% (or more) relative humidity. Over time, nylon backing can dry out and lose its flexibility.

**IN COLD TEMPERATURES;** Nylon backing can crack or shatter. Do not use in temperatures lower than 48° F. Avoid freezing.

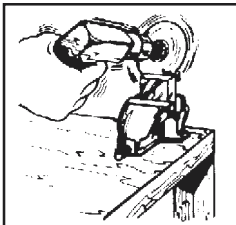

**TIP:** Extend disc life 2-3 times. Renew TRIM-KUT's sharp cutting edge by running the edge against a clamped piece of steel scrap.

# TRIM-KUT® Adapters

5/16-18 male thread. All Pkg: 1 each



Adapter

Mandrel

Part No.	Size	Description
996	1/4" Shank,	Mandrel
997	3/8"-24 UNF	Adapter
998	1/2"-13 UNC	Adapter

# QUICK-LOK™ Discs

(Abrasive Sanding Discs)



## ALUMINUM OXIDE CLOSED COAT • RESIN BONDED

Designed for fast finishing and stock removal on ferrous metals. Use for blending or finishing metal surfaces, light weld removal, removing surface imperfections and mill marks. Offers a better grip than adhesive-back discs. Features a plastic roll-on locking system that quickly secures them to a disc holder.

(Compatible with 3M Roloc backup pads)

Part No.	Diameter	Grit	Pkg Qty
6-484	1"	36, coarse	100
6-485	2"	36, coarse	100
6-486	2"	80, medium	100
6-487	2"	120, fine	100
6-488	3"	36, coarse	50

# Drive Holders

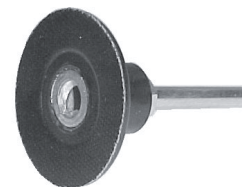

For all button style locking discs. 1/4" shank size. Compatible with Quick-Lok™, Roloc™ and Flex-Finish™ discs. Pkg: 1 each.

Part No.	Fits Disc Diameters	Max. RPM*
6-483	1"	30,000
6-433	1½"	30,000
6-434	2"	20,000
6-435	3"	15,000
6-436	4"	9,000

\*Complies with American National Standards Institute (ANSI) codes.



# Resin Fiber Discs

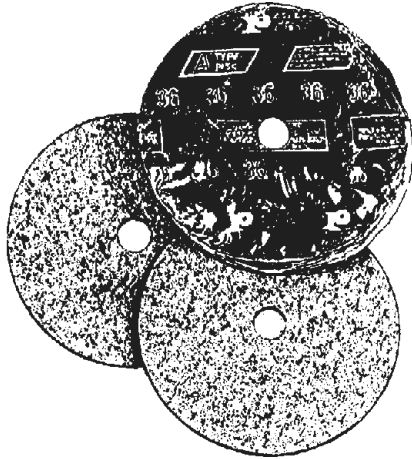

Water repellent, aluminum oxide, resin coated fibre discs for fast metal removal, grinding welds & rust, and metal finishing. Plastic shrink wrapped for longer shelf life. All have 7/8" arbor hole.

Part No.	Diameter	Grit	Pkg
6-041	4-1/2	24	50
6-042	4-1/2	36	50
6-043	4-1/2	80	50
6-044	5"	24	50
6-045	5"	36	50
6-046	5"	80	50
6-047	7"	24	50
6-048	7"	36	50
6-049	7"	80	50

**SAVE WHEN YOU BUY IN QUANTITY!**

# Abrasive Flap Wheels

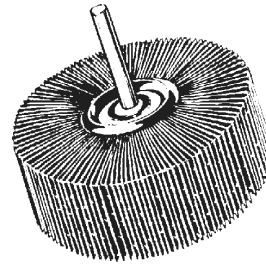

Mounted Flap Wheels - mounted on 1/4" steel shank.  
Aluminum oxide - resin bond cloth

**All 1" wide, 80 grit (medium)**

Part No.	Diameter	Max. RPM*	Pkg
17-52004	1"	30,000	10
17-52016	2"	25,000	10
17-52028	3"	23,000	10

# Rubber Back Up Pads

For Resin Fiber Discs

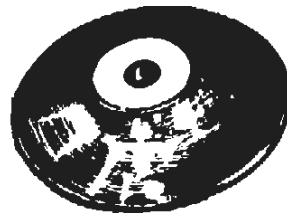

Part No.	Diameter	Center Nut Size
17-152	4"	M10 x 1.25
17-153	4-1/2	M14 x 2.0
17-154	4-1/2	5/8-11
17-155	5"	5/8-11
17-156	7"	5/8-11
17-157	9"	5/8-11

**Red Hot Deals!**

Check out our current specials and new items on our website at <http://www.mpi-online.com>

\*Complies with American National Standards Institute (ANSI) codes.



# Angled Abrasive Flap Discs



**Grinds And Finishes In One Easy Step.** No need to switch from a Type 27 to a resin fiber disc, this disc does it all! Downtime is decreased, saving you time and money.

**Self-sharpening.** New abrasive grain is continually exposed as the layered abrasive flaps slowly wear down providing rapid stock removal and consistent finishing.

**Lasts Longer Than Resin Fiber Discs.** Excellent for grinding metals like steel, aluminum, stainless steel.

**Sturdy Aluminum Backing Plate** takes use and abuse.



## Optimum Working Angle

Angled flaps give consistent finish. More abrasive makes contact with the work surface. Great for curved and rough surfaces.

**Aluminum Oxide Grit** provides the excellent stock removal on low and medium carbon steels.

Part No.	Dia.	Arbor	Grit Size	Max. RPM*	Pkg Qty
6-141	4"	5/8 hole	36	15,000	10
6-142	4-1/2"	7/8 hole	36	13,000	10
6-142A	4-1/2"	7/8 hole	80	13,000	10
6-142B	4-1/2"	7/8 hole	120	13,000	10
6-143	5"	7/8 hole	36	12,000	10
6-144	7"	7/8 hole	36	8,600	10
6-145	7"	5/8-11 hub	36	8,600	10

# Flat Abrasive Flap Discs



**Lightweight Phenolic Backing Plate** will not mar work surface.

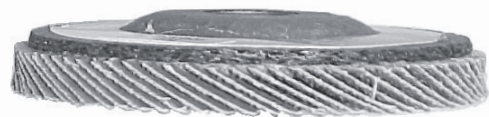

**Extra Long Flaps. Flat Working Angle.** Offers the same features as angled discs except for the flap angle and length. The flat profile produces a consistent finish on contoured, flat and irregular surfaces. Extra-long flaps increase disc life, saving valuable time and money.

**Zirconium Oxide Grit** provides the highest rate of stock removal. Excellent for stainless steels and high carbon steels.

Part No.	Dia.	Arbor	Grit Size	Max. RPM*	Pkg Qty
6-478	4-1/2"	7/8 hole	40	13,000	10

## Adapter Nut Kit

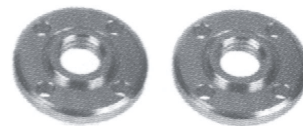

Adapts flap discs with 7/8" arbor holes to fit common 5/8-11 threaded spindles. **Part No. 6-146B**

*\*Complies with American National Standards Institute (ANSI) codes.*



# Surface Conditioning Discs

**ONE-TWIST BUTTON STYLE MOUNTING SYSTEM. TWO POPULAR BRANDS!**

Heavy non-woven nylon, impregnated with abrasive, with a tough reinforced backing. Use for scratch and rust removal, light deburring, gasket removal. Blends ground welds on steel, stainless and aluminum.

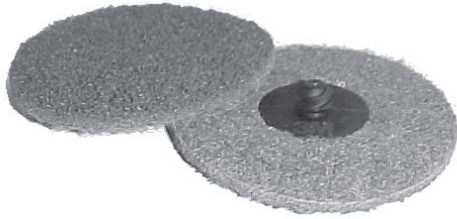

**3M**  
**ROLOC™**

## Surface Conditioning Discs

*Note: medium is maroon in color, coarse is tan in color.*

Part No.	Diam.	Grit†	Max. RPM*	Pkg Qty
6-000	1½	Medium	30,000	50
6-003	1½	Coarse	30,000	50
6-004	2"	Medium	20,000	50
6-005	2"	Coarse	20,000	50
6-010	3"	Medium	15,000	25
6-011	3"	Coarse	15,000	25
6-012	4"	Medium	9,000	10
6-013	4"	Coarse	9,000	10

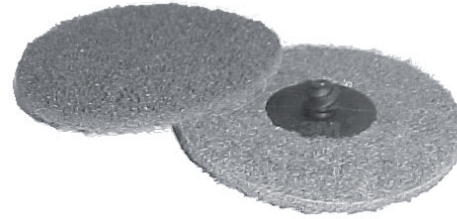

**Weiler**  
**FLEX-FINISH™**

## Surface Conditioning Discs

*Note: medium is maroon in color, coarse is tan in color.*

Part No.	Diam.	Grit†	Max. RPM*	Pkg Qty
6-425	1½	Medium	30,000	50
6-426	1½	Coarse	30,000	50
6-427	2"	Medium	20,000	50
6-428	2"	Coarse	20,000	50
6-429	3"	Medium	15,000	25
6-430	3"	Coarse	15,000	25
6-431	4"	Medium	9,000	10
6-432	4"	Coarse	9,000	10

## Abrasive Hand Pads



Heavy nonwoven nylon impregnated with abrasive particles. 6" x 9" pads for general purpose scuffing, cleaning, finishing and polishing operations on metal, wood and painted surfaces. Industrial grade.

Part No.	Grit†	Color	Brand	Pkg
6-072	Medium	Maroon	Scotch-Brite™	20
6-100	Medium	Maroon	Weiler®	20
6-489	Coarse	Tan	Weiler®	10

•Scotch-Brite is a trademark of the 3M Company

## Drive Holders

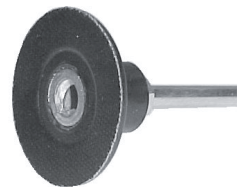

For all button style locking discs. ¼" shank size. Compatible with Quick-Lok™, Roloc™ and Flex-Finish™ discs. Pkg: 1 each.

Part No.	Fits Disc Diameters	Max. RPM*
6-483	1"	30,000
6-433	1½	30,000
6-434	2"	20,000
6-435	3"	15,000
6-436	4"	9,000

†Fine grit discs and pads available on special request, subject to minimum order quantity.

\*Complies with American National Standards Institute (ANSI) codes.

# Wire Wheel Brushes

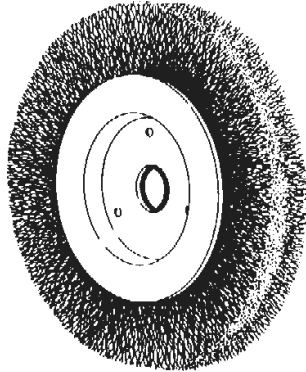

## Standard Duty

These brushes are heavily filled with high quality crimped tempered wire, accurately balanced to provide fine to medium brushing action. They can be used individually or in assemblies mounted on a shaft.

Part No.	Dia.	Wire Size	Face Width	Arbor Size	Max. RPM*
6-093	4"	.012	7/16	3/8-1/2	6,000
6-400	6"	.010	9/16	1/2-5/8	6,000
6-401	6"	.006	9/16	1/2-5/8	6,000
6-402	8"	.010	11/16	1/2-5/8	4,500

*Pkg: 1 each*

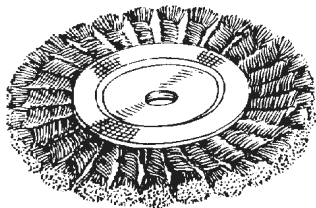

## Knotted - Heavy Duty

These brushes are designed for tough jobs. Highly suited for use in the welding and steel fabrication industries.

Part No.	Dia.	Wire Size	Face Width	Arbor Size	Max. RPM*
6-101	4"	.014	1/2	3/8-1/2	20,000
6-102	6"	.014	1/2	1/2-5/8	9,000
6-103	6"	.016	1"	1/2-5/8	9,000
6-406	8"	.016	5/8	1/2-5/8	6,000
6-407	8"	.016	1-1/8	5/8	6,000

*Pkg: 1 each*

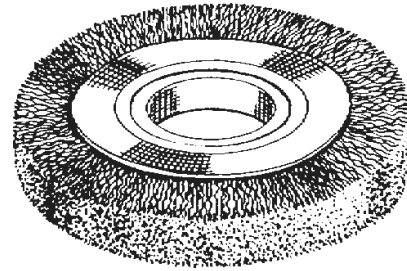

## Heavy Duty

These brushes are heavily filled with highest quality tempered wire. They are designed as general purpose brushing tools for medium to heavy brushing applications. Has 2 inch center hole.

Part No.	Dia.	Wire Size	Face Width	Max. RPM*
6-095	6"	.014	3/4	6,000
6-096	6"	.010	1"	6,000
6-097	6"	.014	1"	6,000
6-098	7"	.014	7/8	6,000
6-099	8"	.014	1-3/8	4,500
6-404	8"	.010	1-3/8	4,500
6-405	10"	.014	1-3/8	3,600

*Pkg: 1 each*

*Note: Arbors must be ordered separately. See below.*

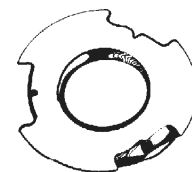

## Arbors

For use with heavy duty wire wheel brushes (above) with 2" center hole.

Part No.	Arbor Size	Pkg Qty
6-420	1/2"	1 Pair
6-421	5/8"	1 Pair
6-422	3/4"	1 Pair
6-423	7/8"	1 Pair
6-424	1"	1 Pair

*\*Complies with American National Standards Institute (ANSI) codes.*



# Small Wire Cup Brushes

## For Small Angle Grinders

Excellent for angle welds, tight operations, corners and curves. Industrial quality.

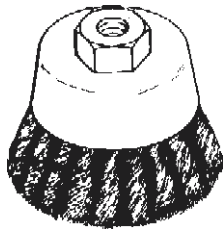

### Twisted Knot Cup Brush

Single Row • Wire size: .020"  
Trim length: 7/8" • Max. RPM\*: 14,000

Part No.	Dia.	Arbor	Pkg
6-384	2-3/4"	5/8-11 UNC	1
6-385	2-3/4"	1/2-13 UNC	1
6-386	2-3/4"	10 mm x 1.25	1
6-387	2-3/4"	10 mm x 1.50	1

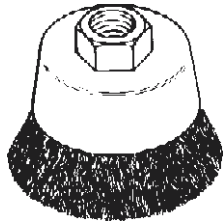

### Crimped Wire Cup Brush

Wire size: .014"  
Trim length: 7/8" • Max. RPM\*: 14,000

Part No.	Dia.	Arbor	Pkg
6-462	3"	5/8-11 UNC	1
6-463	3"	1/2-13 UNC	1
6-464	3"	10 mm x 1.25	1
6-465	3"	10 mm x 1.50	1

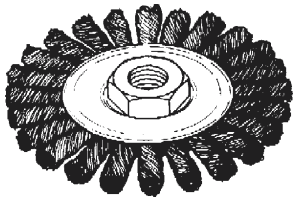

### Twisted Knot Wire Wheel Brush

Stringer Bead Type • Wire size: .020"  
Trim length: 7/8" • Face width: 3/16"  
Max. RPM\*: 20,000

Part No.	Dia.	Arbor	Pkg
6-471	4"	5/8-11 UNC	1

## Small Angle Grinder Reference Chart

Make	Model, Capacity	Arbor Size
AEG	WS601, 4½"	5/8-11
AEG	W750, 4½"	5/8-11
Black & Decker	4247/5580, 4½" 2750/5581, 4½" 4246-09 / 4½" 4252, 5" 6247, 4"	5/8-11 5/8-11 M10 x1.50 5/8-11 M10 x 1.50
Bosch	1347/1348/1348E, 4½" 1347A/1348AE, 5" 7352/111, 5"	M14 x 2.0 5/8-11 M14 x 2.0
Hitachi	G10SD, 4" G12S1, G12SA, 4½"	M10 x 1.50 5/8-11
Ingersoll Rand	8245	5/8-11
Jet	JEG-400, 4" JEG-450, 4½" JEG-500, 5"	3/8-16 5/8-11 5/8-11
Makita	9514B/9501BZ, 4" 9503BHZ, 4½" 9505BHZ/9005B, 5"	M10 x 1.25 5/8-11 5/8-11
Metabo	7115, 4½" AG650SL, 4½" 8125/9123, 5" 1115, 6"	M14 x 2.0 5/8-11 5/8-11 5/8-11
Milwaukee	6140, 6142, 4½" 6145, 4½" 6141, 5" 6146, 5"	5/8-11 1/2-13 5/8-11 1/2-13
Ryobi	SG-100K, 4" G-1155-C, 4½" G-1255-C, 5"	3/8-16 5/8-11 5/8-11
Sioux	1240, 4½" 1245, 5"	M10 x 1.50 5/8-11
Skil	9410/9410:02, 4½" 9611/9611:02, 4½"	M10 x 1.50 5/8-11

**Red Hot Deals!**

Check out our current specials  
and new items on our website at  
<http://www.mpi-online.com>

\*Complies with American National Standards Institute (ANSI) codes.

# Standard Wire Cup Brushes

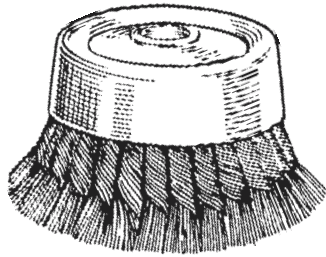

## Twist Tuff Knot Cup Brushes

Low flexibility and high impact action.  
Wire size: .023" • Trim length: 1-3/8"

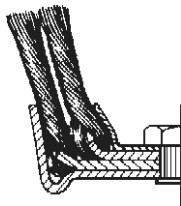

## Heavy Duty Double Row

Knots twisted to the end.

Part No.	Dia.	Arbor	Max. RPM*
6-410	4"	5/8-11	9,000
6-411	6"	5/8-11	6,600

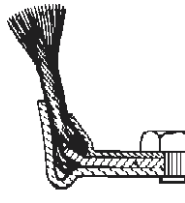

## Standard Twist - Single Row

Knots twisted over part of their length provide medium flexibility.

Part No.	Dia.	Arbor	Max. RPM*
6-412	4"	5/8-11	9,000
6-413	6"	5/8-11	6,600

Sometimes you need to look reality in the eye, and deny it.

-Garrison Keillor

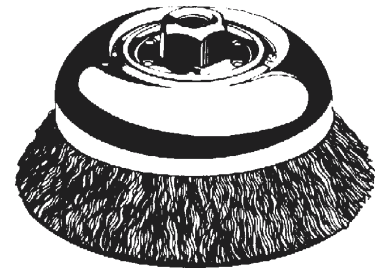

## Crimped Wire Cup Brushes

Wire size: .014" • Trim length: 1-1/8"

Part No.	Dia.	Arbor	Max. RPM*
6-119	4"	5/8-11	9,000
6-120	6"	5/8-11	6,600

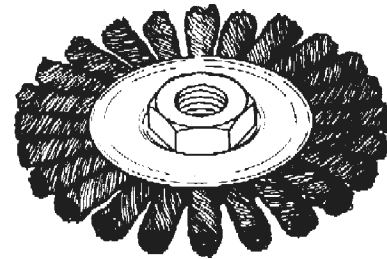

## Twisted Knot Wire Wheel Brush

Stringer Bead Type • Wire size: .020"  
Trim length: 7/8" • Face width: 3/16"  
Max. RPM\*: 9,000

Part No.	Dia.	Arbor	Pkg
6-472	6"	5/8-11 UNC	1

## Reducing Adapters

Fixed 5/8"-11 threaded arbor holes can be adapted to fit most tool arbors. Use with grinding wheels, wire wheel brushes, and wire cup brushes.

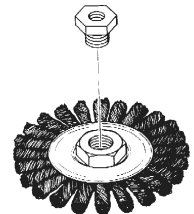

Part No.	Fixed Thread Size	Adapted Thread Size
6-473	5/8-11 UNC	M-10 x 1.25
6-474	5/8-11 UNC	M-10 x 1.50
6-475	5/8-11 UNC	3/8-16

\*Complies with American National Standards Institute (ANSI) codes.



# Wire End Brushes

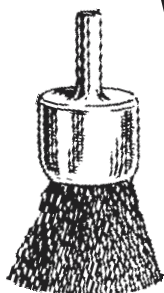

## Straight End Brushes

1/4" Shank.

Part No.	Outside Diameter	Wire Size	Max. RPM*
6-111	1/2"	.010	25,000
6-112	3/4"	.014	22,000
6-113	1"	.014	20,000

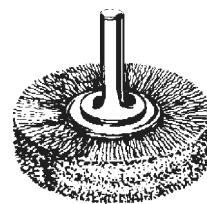

## Circular End Brushes

1/4" Shank.

Part No.	Outside Diameter	Wire Size	Max. RPM*
6-117	3"	.008	20,000
6-118	3"	.014	20,000

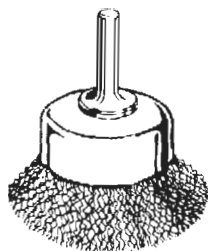

## Hollow Center End Brushes

1/4" Shank.

Part No.	Outside Diameter	Wire Size	Max. RPM*
6-114	1-3/4"	.012	13,000
6-115	2"	.012	13,000
6-116	2-1/2"	.012	13,000



## Low Profile Drive Arbors

Inner locking nut. Low profile shank adapter for use with Cut-Off Wheels and Wire Brushes.

Part No.	Arbor Diam.	Stem Diam.	Max. RPM*
6-109	3/8"	1/4"	20,000
6-110	1/2"	1/4"	20,000

## Tube Fitting Brushes



Internal type wire brush cleans and preparing copper tubing and sweat fittings. Plastic handle.

PART NO.	Tubing I.D.	PKG. QTY
6-136	1/4"	1
6-137	3/8"	1
6-138	1/2"	1
6-139	5/8"	1
6-140	3/4"	1



## Quick Change Drive Arbors

Quickly adapts small diameter Cut-Off Wheels and Wire Brushes without removing arbor from tool.

Part No.	Arbor Diam.	Stem Diam.	Max. RPM*
6-104	1/4"	1/4"	20,000
6-105	3/8"	1/4"	20,000
6-106	1/2"	1/4"	20,000

\*Complies with American National Standards Institute (ANSI) codes.

# Miscellaneous Brushes

## Disposable Chip & Oil Brushes



Excellent disposable brush for oiling, gluing, chip removal, and painting. White hog bristle, plated ferrule, wood handle. Imported.

PART NO.	BRUSH WIDTH	PKG. QTY
6-415	1"	30
6-416	1-1/2"	30
6-417	2"	20
6-418	3"	10
6-419	4"	10

## Truck Wash Brushes

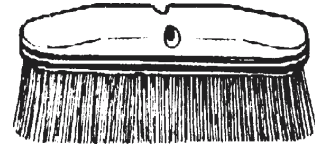

Great for windows too! Soft, flagged white polystyrene trim with protective plastic bumper, plastic block. Accepts fountain tube handle (below), threaded wood handles and tapered handles. *Order handles separately.* Block size: 9-1/2" x 2-3/4". Trim length: 3" Pkg: 12 each **Part No. 6-002**

## Can, Wheel & Fender Brushes

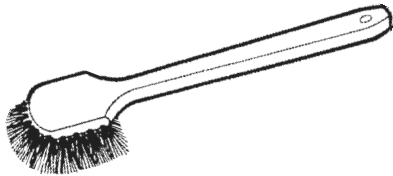

Synthetic fibre is resistant to gasoline and petroleum based substances. Dairy, automotive and industrial applications. Plastic block: 20" x 3". Face: 5-1/2" x 6-1/2". Pkg: 12 each. **Part No. 6-121**

## Fountain Tube Handle

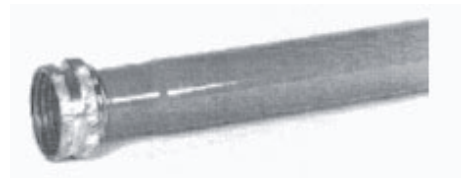

Metal handle attaches to water hoses or nozzles for convenient water flow when scrubbing vehicles. for use with truck wash brush above. Size: 7/8" dia. X 5 ft long. 12 per carton. **Part No. 6-001**

## Parts Brushes

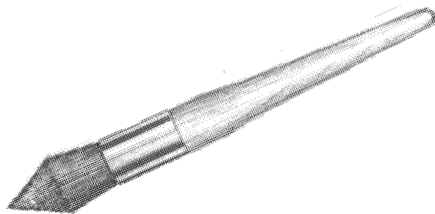

Plastic handles. Bright metal ferrules. Pkg: 12 each

PART NO.	TRIM DIAM.	TRIM LENGTH	BRUSH STYLE	TIP STYLE
6-122	1-3/16	2-5/8	Med. Tampico	Pointed
6-123	1-1/16	3"	Stiff Polypropylene	Pointed
6-124	1"	2-1/2	Soft Bristle	Round

## Acid Brushes



A handy brush for applying solder fluxes, oils, greases and glues. Tin handles. Horsehair filled.

PART NO.	BRUSH WIDTH	LENGTH	PKG. QTY
6-125	1/2"	6"	144
6-126	5/8"	6"	144



# Wire Scratch Brushes

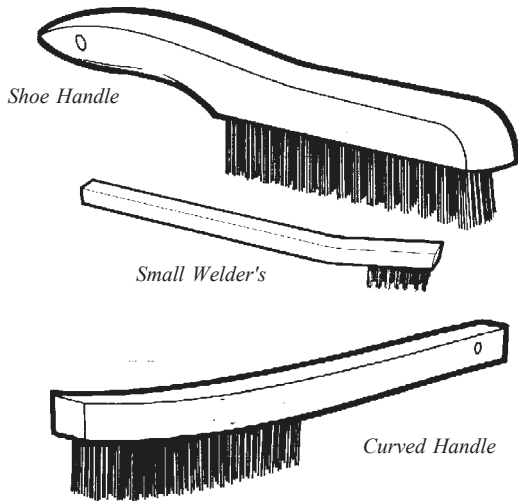

Choose from carbon steel or stainless steel wire.  
Solid wood handles.

PART NO.	DESCRIPTION	ROWS OF WIRE	PKG. QTY.
<b>SHOE HANDLE BRUSHES</b>			
6-133	Carbon Steel	4	12
6-134	Carbon Steel w/Scraper	4	12
6-135	Stainless Steel	4	12
<b>CURVED HANDLE BRUSHES</b>			
6-130	Carbon Steel	3	12
6-131	Carbon Steel w/Scraper	3	12
6-132	Stainless Steel	3	12
<b>SMALL WELDER'S BRUSHES*</b>			
6-128	Stainless Steel	4	12

*\*Also available in brass.*

**SAVE  
WHEN YOU  
BUY IN  
QUANTITY!**

# Upright Corn Brooms

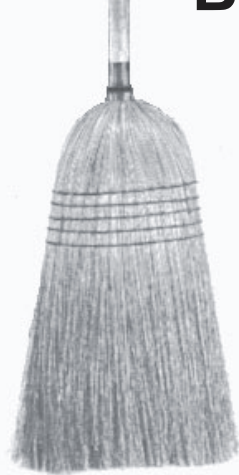

Industrial quality broom for light sweeping on most any type of floor. Heavy duty triple stitched and steel wire banded. 12" sweep. 1-1/8" diameter x 38" long handle. 56" overall length.  
Pkg: 6 each. **Part No 6-185**

# Whisk Brooms



Select palmetto fibre. Double stitched for extra strength. Compact 7-1/2" overall. Pkg: 12 each. **Part No 6-129**

# Bench Brushes

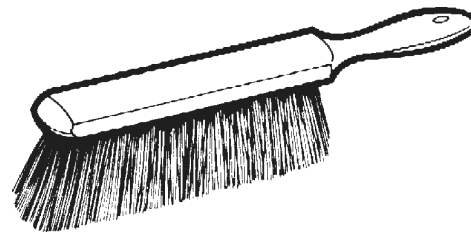

Horsehair reinforced with nylon. 10" lacquered wood block. Pkg: 1 each. **Part No. 6-127**



# Floor Brushes

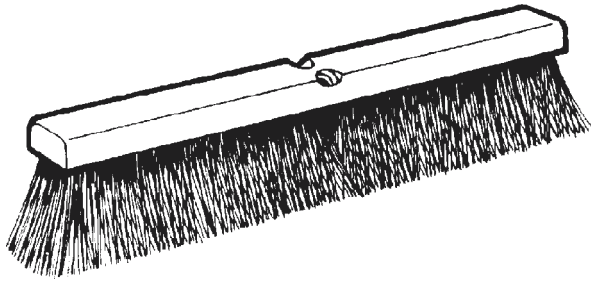

With laquered hardwood blocks.  
Handles must be ordered separately.

Part No.	Description	Pkg Qty
----------	-------------	---------

## Fine - Flagged Silver Synthetic

For fine debris on polished or smooth floors. Split-flagged ends. 3" trim.

6-918	18"	12
6-924•	24"	12

Use threaded handle #6-186.

## Medium - Black Synthetic

For fine to medium soil. Water and oil resistant. 3" trim.

6-179	18"	12
6-183•	24"	12

Use threaded handle #6-186.

## Coarse - Red Synthetic

An all purpose brush for most liquids or solid debris on medium to coarse surfaces. 3¼" trim.

6-180	18"	12
6-184•	24"	12

Use threaded handle #6-186.

## Extra Coarse - Palmyra

A very good parking lot brush; use for heavy debris on rough or coarse surfaces. 4" trim. Can be used wet or dry.

6-618	18"	1
6-624•	24"	1

Use threaded handle #6-186.

• Note: 24" brushes come with one 6-176 standard brace.



# Palmyra Street Broom

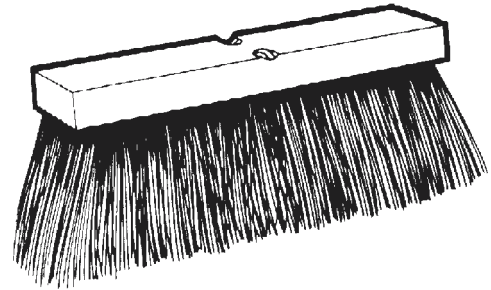

Can be used wet or dry. 6" trim length.

Part No.	Length	Pkg
6-181	16"	6

Use tapered handle #6-187.

# Broom Handles

Die-Cast  
Threaded End

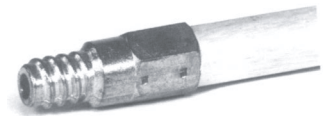

Tapered End



Fiberglass  
Handle



NEW ITEM

Part No.	Material	Style	Pkg
6-186	Wood	60" Threaded	12
6-187	Wood	60" Tapered	12
6-188	Fiberglass (hollow)	60" Threaded	1

# Handle Braces

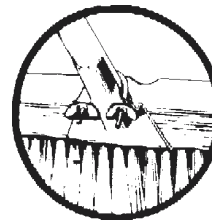

Clamp Brace  
Part No. 6-176

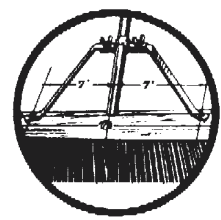

Teepee Brace  
Part No. 6-177



# Squeegees



## Window Squeegees

Plated steel frame and handle socket. Angle front type. Two quality rubbers securely fastened by machine screws.

Size	PART NUMBER		Pkg Qty
	Squeegee	Extra Rubbers	
12"	6-160	6-168	1
18"	6-161	6-169	1

*Use tapered handle #6-187 - order separately.*



## Steel Frame Floor Squeegees

Size	PART NUMBER		Pkg Qty
	Squeegee	Extra Rubbers	
<b>Straight Squeegees</b>			
18"	6-162	6-170	1
24"	6-163	6-173	1
<b>Curved Squeegees</b>			
24"	6-165	6-173	1
36"	6-167	6-175	1

*Use tapered handle #6-187 - order separately.*



# Mops & Mop Handles

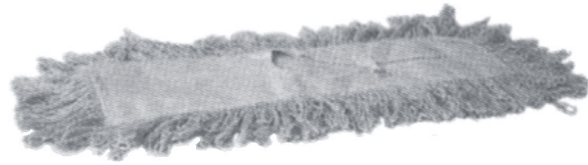

## Professional Dust Mops, Metal Frames & Handles

Tie-on style, 4-ply cotton mop heads. Metal support frames are 5" wide. Dust mop handles are 54" long. All sold separately.

Size	Mop Head	Metal Frame	Handle	Pkg Qty
24"	6-050	6-051	6-189	1
36"	6-052	6-053	6-189	1



## Wet Mop Heads & Handles

Industrial grade. Loose end, 8-ply cotton mop heads. Mop handles are 54" screw type (sold separately).

Weight	PART NUMBER		Pkg Qty
	Mop Head	Mop Handle	
24 oz.	6-054	6-190	1
32 oz.	6-055	6-190	1

The easiest way to get rid of a difficult task is to do it.

# Adhesives

## LOCTITE

### Prism® Instant Adhesive Gel



Prism® is the ideal instant adhesive for porous substrates. Prism® is a surface insensitive cyanoacrylate for difficult-to-bond substrates, including rough, porous and acidic surfaces. Fills gaps on poorly mated

surfaces. Non-run gel formulation is great for vertical applications. Applications: leather, metals, rubber, paper, foam, soft woods, plastics and ceramics. **Gap fill: .010"**. Color: Clear. Fixture: 15 seconds. Full cure: 24 hours. Temperature range: -65°F to 180°F.

Part Number	Size	Pkg Qty
LT-45404 .....	3 gm. (.10 oz.) tube .....	10
<i>Formerly "Power Gel"</i>		

## LOCTITE Contact Adhesive

Fast drying, waterproof neoprene based adhesive bonds rubber, wood, metal and other porous materials. Withstands temperature extremes and is resistant to gasoline, kerosene and other solvents. Applications: insulation, moldings, weather-stripping and carpeting. *Sets to tack-free surface in 3-4 minutes before assembly. Allows repositioning after initial contact. Temperature limit: +180° F. Color: yellow.*



Part Number	Size	Pkg Qty
LT-30537 .....	5 oz. ....	12
<i>Formerly "Super Weatherstrip Adhesive"</i>		

## LOCTITE Super Bonder® Instant Adhesive



Super Bonder® is the general purpose instant adhesive liquid everyone needs in their tool box for general maintenance and repair. It sets instantly with no clamping, no mixing, no waiting; and it bonds just about anything. Strong bonds on metal, rubber, plastic and other nonporous surfaces. Applications: rubber belts, bumpers, wires, plastic nameplates, signs, trim, etc. *Color: Clear. Fixture: 5-50 seconds. Full cure: 24 hours. Temperature range: -65°F to 180°F.*

Part Number	Size	Pkg Qty
LT-49550 .....	1 oz. (28 gm) bottle .....	10
<i>Formerly "Super Glue"</i>		

## LOCTITE Black Max® Toughened Instant Adhesive



Black Max® is the instant adhesive choice for parts that encounter shock, vibration or thermal cycling. This black, toughened cyanoacrylate adhesive uses elastomers to withstand impact and challenging environmental conditions. Withstands impact, solvents, and thermal cycling. No mixing, heating, or clamping. Applications: most rubber, plastic and metal substrates; belts that will see vibration; rubber seals on underground junction boxes. *Gap Fill: .006". Color: Black. Fixture: 90 seconds. Full cure: 24 hours. Temperature range: -65°F to 225°F.*

Part Number	Size	Pkg Qty
LT-38004 .....	3 gm (.10 oz.) tube .....	10
LT-38050 .....	28 gm (1 oz.) bottle .....	10
<i>Formerly "Black Belt"</i>		

# Adhesives

## J-B Weld Cold Welding Compound



The worlds finest cold-weld. Drill it! Grind it! Machine it! Indispensable for mechanics, farmers, homemakers and almost everyone! Applications: valve seats, cylinder sleeves, engine blocks, torn keyways, fuel tanks, water tanks and tubs, body shop repairs, press fit bearings, leaks in

pipes, weld cracks and pin holes, aluminum boats, porcelain, ceramic and more! Nonconductive. Tensile strength: 3,960 psi. Handling strength: 4-6 hours. Full cure: 15 hours. Temperature limit: 600° F. Color: gray.

Part Number	Size	Pkg Qty
30-002	1 oz. Twin Tubes (carded)	6



## Magic Metal Copper Filled Epoxy Putty



### SUPERIOR TENSILE STRENGTH AND TEMPERATURE RESISTANCE! CURES IN JUST ONE HOUR!

Magic Metal can be drilled, tapped, filed, sanded, machined or painted within an hour! Corrosion-resistant and wear-resistant bronze epoxy putty for use on all metals, wood, concrete, brick, glass, ceramic and plastic. Hand kneadable putty stick is easy to measure. Use on tanks, welds, pipes, cracks, pin holes and more. Use to strengthen weakened parts. Tensile strength: 8,200 psi. Fixture time: 10 minutes. Full cure: 1 hour. Temperature limit: 360° F. Color: bronze.

Part Number	Size	Pkg Qty
16-0011	4 oz. net wt. stick	12

*\*Packaged in resealable tube*



## Fixmaster® Poxy-Pak Fast Cure Epoxy



This fast cure, high strength liquid epoxy bonds virtually any material in minutes. Repair, fill and seal holes, cracks and worn surfaces. Convenient re-sealable syringe dispenser means no measuring, no mess, and no waste. Applications: Metal, ceramic, concrete, wood, glass, and plastic. May be drilled, sanded, machined, and painted. Working time: 1 minute. Fixture time: 4-6

minutes. Full cure: 1 hour. Adhesive tensile shear: 2300 psi. Temperature limit: 250° F. Color: clear.

Part Number	Size	Pkg Qty
LT-81120	1 oz.	12



## Fixmaster® Fast Cure Epoxy Mixercups



### PRE-MEASURED ONE-SHOT CUPS

No mess, no waste. Bonds in 5 to 15 minutes. Excellent chemical resistance. Fills porosities and can be used to build up worn parts. Ideal for bonding metal, glass, hard plastics, marble, ceramic, brick, concrete and wood. Working time: 5 minutes. Fixture time: 10 minutes. Full cure: 12 hours. Adhesive tensile shear: 2000 psi. Temperature limit: +180° F. Color: gray.



Part Number	Cup Size	No. Cups Per Can	Pkg Qty
LT-21425	4 gm	10	10 cans

*\*Packaged in resealable cans*



# Adhesives

## LOCTITE

### Fixmaster® Magna-Crete® Concrete Repair Kit



**CAN BE APPLIED AT VIRTUALLY ANY TEMPERATURE!**

Two-Component, rapid setting concrete repair, anchoring and grouting system. Use to repair or restore floors, ramps, loading docks, rail grouting, leveling and setting machinery, grouting bedplates and soleplates, and anchoring bolts and handrails. Chemical resistant to most common liquids and chemicals. Bonds to concrete, wood, glass, steel and other construction materials. Nonshrinking. Compressive strength; 13,000 psi. Coverage: 4.8 sq ft per container. Fixture speed: 15 minutes. Functional cure: 1-2 hours. Max. temperature; 2000°F Color: grey.

Part Number	Size	Pkg Qty
LT-95551	1 Gal. Kit	1

*Five gallon kit available on special request.*

### Heavy Duty Adhesive Spray



**WIDE WEB SPRAY**

The special nozzle applies adhesive as a wide web for application to all surfaces... smooth, uneven and porous. Permanent and repositionable adhesive is fast-setting, flexible, waterproof and resistant to moisture and temperature extremes. Cleans up with mineral spirits or solvent. Use on weather-stripping, carpets, trim moulding, glass, fiberglass,

metal, leather, cork, wood, vinyl, paper, cardboard, rubber, cloth and most plastics. Misty brand.

Part Number	Size	Pkg Qty
16-0063B	12 oz. net wt. Aerosol	12

## LOCTITE

### Threadlocker 222MS Low Strength/Small Screws (Purple)

Formulated for easy removal of miniature screws 1/4" (6mm) diameter and smaller, long engagement length fasteners and components requiring occasional adjustment. Parts can be disassembled with hand tools. Applications: miniature screws, adjustment screws, calibration screws, meters and gauges. Fixture speed: 20 minutes. Full cure: 24 hours. Temperature range: -65°F to 300°F. Color: purple.



Part Number	Size	Pkg Qty
LT-22221	10 ml.	10

*Formerly "Locks Screws" (28653)  
50 ml and 250ml bottles available on special request.*

### ND VIBRA-TITE Formula 3

**REUSABLE UP TO FIVE TIMES!  
INDEFINITE SHELF LIFE!**

Use on male or female threads of virtually any material or finish. Dries to the touch within seconds, ready for assembly in just a few minutes! Fasteners pre-coated with Vibra-Tite can be stored indefinitely. Pre-cleaning not required except for wiping off any visible oil on threads. Parts coated with Vibra-Tite can be easily adjusted, removed, and reused 5 or more times. Minimizes galling and stripping of soft threads during reuse. Applications: From tiny eyeglass screws to huge construction bolts. Use on fasteners of any size. Adheres to all metals and finishes. Can be used on plastic and nylon screws. Shelf life: Indefinite. Cure time: 5-10 minutes (one coat). Temperature range: -65°F to 165°F. Appearance: Red viscous liquid.



Part Number	Size	Pkg Qty
30-001	1 oz. brush-top bottle	10



# Anaerobics & Thread Sealants

## LOCTITE

### Threadlocker 262® Permanent Strength (Red)



Threadlocker 262® is a permanent, high strength threadlocker that locks large fasteners and offers heavy duty protection against shock and vibration. Use Locks Studs on large fasteners from 3/8" to 1" diameter. Resists solvents, oils, and water immersion. Localized heating and hand tools are required to separate parts. Applications: all fasteners that must withstand heavy shock, vibration, or extreme environmental or chemical conditions. *Fixture speed: 20 minutes. Full cure: 24 hours. Gap fill .005". Temperature range: -65°F to 300° F. Color: red.*

Part Number	Size	Pkg Qty
LT-26221	10 ml.	10
LT-26231	50 ml.	10

*Formerly "Locks Studs" (81791, 81792).  
250ml bottles also available on special request.*

## LOCTITE

### Threadlocker 242® Removable Strength (Blue)



Threadlocker 242® is a removable strength threadlocker especially well suited for small fasteners between 1/4" and 3/4" diameter. Parts can easily be disassembled with hand tools. Applications: machine tools, presses, pumps, compressors, mounting bolts, gearboxes. *Fixture speed: 20 minutes. Full cure: 24 hours. Gap fill .005". Temperature range: -65°F to 300° F. Color: blue.*

Part Number	Size	Pkg Qty
LT-24221	10 ml.	10
LT-24231	50 ml.	10

*Formerly "Locks Nuts" (81788, 81789)  
250ml bottles also available on special request.*

## LOCTITE

### Threadlocker 290 Wicking Grade



A low viscosity, penetrating threadlocker that wicks along the threads of pre-assembled fasteners to secure them in place. Prevents vibration loosening on small diameter fasteners to 1/2". Seals porosities in welds and metal parts. Localized heating and hand tools are needed for disassembly. Applications: pre-assembled fasteners, instrumentation screws, electrical connectors, carburetors. *Fixture speed: 10 minutes. Full cure: 24 hours. Gap fill .004". Temperature range: -65°F to 300° F. Color: green.*

Part Number	Size	Pkg Qty
LT-29021	10 ml.	10

*Formerly "After Lock" (81794).  
50 ml and 250ml bottles also available on special request.*

## LOCTITE

### Thread Sealant 545 Hydraulic/Pneumatic Sealant



Seals hydraulic and pneumatic fittings without danger of contamination. It contains no fillers or particles and disassembles with hand tools. Applications: pneumatic fittings, shop air hoses and lines, hydraulic fittings, O-ring fittings, servo mechanisms. *Pressure resistance: 10,000 psi. Seals to operating pressure in 4 hours. Full cure: 12-24 hours. Temperature range: -65°F to 300° F. Color: purple.*

Part Number	Size	Pkg Qty
LT-32429	10 ml.	10
LT-54531	50 ml.	10

*Formerly "Hydraulic Sealant" (51456, 81802).  
250ml bottles also available on special request.*

# Anaerobics &

## LOCTITE

### Retaining Compound 609 General Purpose

A low viscosity, fast-curing adhesive used for bonding non-threaded metal-to-metal assemblies. Prevents wear on new parts and restores fit to worn parts. Use on bearings, bushings, sleeves, shafts, keys, splines and cylindrical assemblies. Allows slip fits instead of press fits. *Shear strength: 3,000 psi. Gap fill: .005". Fixture time: 10 minutes. Full cure: 24 hours. Temperature range: -65°F to 300° F. Color: green.*



Part Number	Size	Pkg Qty
LT-60921 .....	10 ml. bottle .....	10
<i>Formerly Prolock Secures Gears (81797)</i>		
<i>50 ml bottle also available on special request.</i>		

# Thread Sealants

## LOCTITE

### Thread Sealant 565 PST® Controlled Strength

Formulated specifically for metal, tapered pipe thread fittings. High performance pipe sealant withstands pressures up to 5000 psi. This anaerobic product cures rapidly to provide instant low pressure sealing. Easy applicator dispenses paste in a wide, uniform band for less waste. *Seals to 10,000 psi operating pressure in 4 hours. UL Classified. AGA approved. Temperature range: -65°F to 450° F. Color: White.*



Part Number	Size	Pkg Qty
LT-56531 .....	50 ml. ....	10
<i>Formerly Seals Pipes (81800)</i>		

## LOCTITE

### Quick Metal® Press Fit Repair Retaining Compound

Repairs worn shafts, couplings, and housings in one hour. Non-running gel fills imperfections and gaps up to .020". Keep machinery up and running until new parts arrive. Repair worn keyways, loose set screws, form shims in place, stop bearing spin-out, and protect new parts from wear. *Fixture speed 10-30 minutes. Full cure 1-2 hours. Gap fill .020". U.S.D.A. approved. Silver in color.*



Part Number	Size	Pkg Qty
LT-66010 .....	6 ml. ....	10
<i>Formerly Prolock Press Fit Repair (81962)</i>		
<i>50 ml and 250ml bottles also available on special request.</i>		

## LOCTITE

### Thread Sealant w/Teflon®

This chemical resistant sealant outperforms teflon tape. Non-hardening sealant has the added lubricity of Teflon for easy disassembly of metal pipes. Resistant to most shop fluids and gases. *Seals to 5,000 psi Temperature range: -60°F to 300° F. Color: white.*



Part Number	Size	Pkg Qty
LT-30534 .....	1/4 pt (4 oz.) .....	12
LT-30561 .....	1 pt (16 oz.) .....	12

## LOCTITE

**Locquic 7649 Primer N**  
(Anaerobic Activator) Speeds setup time of threadlockers and retaining compounds. Increases breakaway torque on fastener surfaces. Allows cold weather application of anaerobics.



Part Number	Size	Pkg Qty
LT-21348 .....	4.5 oz. Aerosol Spray .....	10

## LOCTITE

### Pipe Joint Compound

Economical, nonhardening pipe thread sealant. Will not shred like teflon tape. *Seals to 5,000 psi. Temperature range: -65°F to 400° F. Color: black paste.*



Part Number	Size	Pkg Qty
LT-30556 .....	1/4 pt (4 oz.) .....	12
LT-30557 .....	1 pt (16 oz.) .....	12



# Cleaners

## Liquid Steam Cleaning Concentrate



Heavy duty cleaner/degreaser formulated for use with high temperature steam cleaners and pressure washers. Highly concentrated. Quickly removes grime, oil and grease from metal, concrete and painted surfaces.

Special inhibitors protect your steam cleaners' heating coils from scaling and corrosion. *Designed to remove heavy grime at a 1:20 dilution ratio. Lighter cleaning chores mix up to 1:40. USDA category A1.*

**NOTE: PAIL & DRUM CONTAINERS CANNOT BE SHIPPED VIA U.P.S.**



Part Number	Size	Pkg Qty
16-405GL	1 gal. Bottle (UPS-able)	4
16-405PL	5 gal. Pail (NOT UPS-able)	1
16-405DR	55 gal. Drum (NOT UPS-able)	1

## Orange Degreaser



This natural formula is free of petroleum distillates and contains orange peel extracts. Great for cleaning equipment, motors, metal parts, concrete and wood floors, garbage cans, adhesives and carpet backing from

subfloors. Works well in parts washers and pressure washers. *Dilute with water or apply full strength, then flush surface with a power sprayer. USDA category C1\*.*

Part No.	Size	Pkg Qty
16-A378*	12 oz. Aerosol	12
16-378PT	1 pint can	12
16-378GL	1 gal. Bottle	4
16-378PL	5 gal. Pail	1
16-378DR	55 gal. Drum	1

*\*Note: Aerosol propellant not USDA authorized.*

## Multipurpose Cleaner & Degreaser



Environmentally friendly nonbutyl concentrated detergent cleaner. Cleans and degreases without harsh solvents, butyls or alcohols. Money saving concentrate replaces ready-to-

use cleaners and presoaks. May be used in automatic scrubbers, pressure washers, hot tanks and spray cleaners. Use on painted surfaces, walls, floors, appliances counter-tops, tile, grout, grills, bathrooms and more. Does not irritate skin. *Dilute with water as required. Degreaser 1:1, medium duty 10:1, light duty 30:1, glass and mirrors 150:1. USDA category A1.*

Part Number	Size	Pkg Qty
16-411GL	1 gal. (128 oz.) bottle	4
16-411PL	5 gal. Pail	1

## Neoprene Liquid Proof Gloves



Part No.	Length	Cuff	Pkg
21-265	10"	Knit wrist	12
21-266	12"	Gauntlet	12
21-267	14"	Gauntlet	12
21-268	18" (Elbow)	Gauntlet	6
21-269	31" (Shoulder)	Gauntlet	6



# Cleaners

## Citra Crystals Powdered Concrete Floor Cleaner



WITH COLOR INDICATOR  
Brightly colored orange powder changes to a highly visible lime-green color to indicate where it has been applied to wet floor. The darker the solution color, the stronger the cleaner concentration. Citra Crystals utilizes detergents and d'Limonene extracts, a potent natural solvent that penetrates grease and grime. Can be diluted with water for sponge mopping floors, walls and power washing too. *Fresh orange scent. Biodegradable. USDA category C-1.*

Part Number	Size	Pkg Qty
16-665	50 lb. Drum	1

## Concentrated Car Wash & Wax



One-step cleaning and waxing saves time. Restore highest lustre to finish on cars and trucks as well. Leaves your vehicle spotless and film-free with a glossy wax finish. *Biodegradable. Concentrated formula must be mixed with water.*

Part Number	Size	Pkg Qty
16-120GL	1 gal. Bottle	4
16-120PL	5 gal. Pail	1

## Concentrated Aluminum Cleaner



**POWERFUL ACID BLEND**  
Heavy duty blend of powerful acids and detergents for fast and complete removal of oxidation from aluminum surfaces. Ideal for use on: trailer bodies, aluminum wheels, boats, and exterior aluminum sidings. *Concentrated product must be diluted with water. Use with care on painted surfaces. Warning: Contains Hydrofluoric and Sulfuric Acids.*

**NOTE: THIS ITEM CANNOT BE SHIPPED VIA U.P.S.**



Part Number	Size	Pkg Qty
16-103PL	5 gal. Pail	1

## Concentrated Truck Wash

Formulated for volume washing of truck fleets, construction equipment, farm implements and more. Cuts through dirt, diesel fuel, road film and grime. Safe to use on aluminum surfaces. *Ultra concentrated liquid allows 1:2 mix with water, then set the dilution ratio to 1:25 on your pressure washer.*



**NOTE: THIS ITEM CANNOT BE SHIPPED VIA U.P.S.**



Part Number	Size	Pkg Qty
16-118PL	5 gal. Pail	4
16-118DR	55 gal. Drum	1



# Cleaners



## MPI Streak-Free Glass & Mirror Cleaner

This foaming action glass cleaner is formulated with ammonia. Cleans fast without streaks. Thoroughly cleans dirt and grime while leaving a pleasant fragrance. Use to wipe away fingerprints, smudges, dust, dirt, oil, grease, bugs and road spatter. Use on glass doors, windows, showcases, windshields and headlights. MPI brand.

Part Number	Size	Pkg Qty
16-0075B .....	Net wt. 19 oz. Aerosol .....	12



## Gelled Engine Degreaser

Organic, biodegradable gel clings to vertical surfaces to emulsify dirt, oil, grease, tar, asphalt and creosote. Spray it on, let sit for 10 to 20 minutes and hose it off. Contains no chlorinated solvents, acids, alkalis or petroleum distillates.

Part Number	Size	Pkg Qty
16-0042B .....	Net wt. 13 oz. Aerosol .....	12



## Citra-Grime Multi-Purpose Deodorizing Cleaner

Citra-Grime is a powerful foam cleaner that clings to any hard surface to provide extended cleaning contact time in vertical and overhead positions. Use on any surface not affected by water - Formica, rubber, wood, concrete, plastics, porcelain, vinyl, painted surfaces, fiberglass, metal, tile, walls, machinery and more.

*Convenient spray-any-way" 360° valve. Does not contain chlorinated solvents or petroleum distillates. Biodegradable. USDA authorized. Fresh citrus aroma.*

Part Number	Size	Pkg Qty
30-216B .....	Net wt. 18 oz. Aerosol .....	12



## Stay Bathroom Cleaner/Disinfectant

Effectively clean toilet bowls, urinals, tubs, shower stalls, sinks and faucets. Cuts through heavy rust deposits, soap scum, heavy calcium deposits and hard water stains. Applications: Nonporous surfaces such as fiberglass, chrome, stainless steel, vitreous, glass, plastic, aluminum, glazed porcelain, tile, grout, ceramic and terrazzo surfaces. Product must remain on surface for 10 minutes or more. *Warning: Phosphoric acid based formula. Wear goggles and rubber gloves when using this product. Do not use on marble surfaces.*

**NEW ITEM!**

Part Number	Size	Pkg Qty
31-723 .....	1 quart spout-top bottles .....	12

---

Legendary explorer Daniel Boone died September 26, 1820 from indigestion after eating too many sweet potatoes.

---

# Cleaners

## MPI Brake-Wash NONFLAMMABLE

Powerful fast-acting solvents cleans brake parts without disassembly. Dries fast and residue-free. Powerful spray dissolves and flushes brake fluids and contaminants from brake parts. Use on brake linings, disc pads, calipers, drums, cylinders, C.V. joints, springs and other metal parts. Stops squeal caused by contaminants. *Non-hazardous to atmosphere. Includes snorkel. MPI brand.*



Part Number	Net Weight	Pkg Qty
16-0019B	18 oz.	12

## Blast-Off Safety Solvent NONFLAMMABLE

This powerful cleaning solvent removes grease, oil, dirt, tar, gasket adhesives, crayon, ink and fresh paint. Can be used to clean electric motors of all types while equipment is in operation. Quiets down noisy electric power tools. Use on metal parts, ignition systems, power and hand tools, housings and covers, fuse boxes, meters, typewriters, generators, small engines, motorcycle engines, etc. *Safe to use on most plastics†. Non-hazardous to atmosphere. Includes snorkel. MPI brand.*



Part Number	Net Weight	Pkg Qty
16-0074B	20 oz.	12

† Not for use on polystyrene, styrofoams or polycarbonates.

## Brake & Parts Cleaner II ECONOMICAL

Highly concentrated solvent blasts away deposits, fluids and contaminants from brake linings, pads, drums, cylinders and springs without disassembling the brake unit. Dries fast and residue free. *Nonhazardous to atmosphere. Includes snorkel. Misty brand.*



Part Number	Net Weight	Pkg Qty
16-0109B	14 oz.	12

*Warning: Extremely flammable. Adequate ventilation required.*

## Master® NonChlorinated Brake Cleaner

Low cost nonchlorinated formula contains fast-acting solvents that dry fast and residue free. Dissolves and flushes away grease, dirt and fluids from pads, calipers, drums, cylinders, springs and other metal parts. *Nonhazardous to atmosphere. Includes snorkel. Master brand.*



Part Number	Net Weight	Pkg Qty
MS-BCN-20	15 oz.	12

*Warning: Extremely flammable. Adequate ventilation required.*

## MPI Bulk Safety Solvent

A nonflammable industrial cleaning solvent for use on metal and rubber parts, brake parts and pads. Dries fast and residue-free. Dissolves grease, oil, fluids and contaminants. *Non-flammable. Non-hazardous to atmosphere. MPI brand.*

Part Number	Net Weight	Pkg Qty
16-310GL	128 oz. (1 gal)	4

*Available in pails and drums.*

## Master® Nonflammable Brake Cleaner

Efficient nonflammable formula contains fast-acting solvents that dry fast and residue free. Dissolves and flushes away grease, dirt and fluids from pads, calipers, drums, cylinders, springs and other metal parts. *Includes snorkel. Master brand.*



Part Number	Net Weight	Pkg Qty
MS-BC-20	18 oz.	12

**YOU ORDER TODAY, WE SHIP  
TODAY! WHY WAIT?**



# Cleaners



## Contact & Circuit Board Cleaner II

**NONFLAMMABLE FORMULA**  
Safe to use on energized equipment. Cleans oil, grease, dirt, condensation and moisture from circuit boards, precision equipment, relays, telephone and communication equipment, motors, switches, television and satellite components. Dries fast and residue free. This formula was developed for Aeronautics and communications industries. *Safe to use on metal, rubber and most plastics. Not for use on styrene or polystyrene surfaces. Nonconductive to 26,000 volts. Nonflammable. Includes snorkel.*

*use on metal, rubber and most plastics. Not for use on styrene or polystyrene surfaces. Nonconductive to 26,000 volts. Nonflammable. Includes snorkel.*

*Contains materials with 85% less ozone depleting potential than traditional contact cleaners.*

Part Number	Size	Pkg Qty
16-0107B .....	Net wt. 14 oz. Aerosol .....	12
16-310GL .....	1 gallon Bottle .....	4



## Choke & Carb Cleaner

**POWERFUL BLASTING SPRAY**  
Cleans carburetors, chokes and fuel injectors with a very powerful blasting spray. Improves engine acceleration and performance. Instantly dissolves carbon, gum and varnish deposits to bare metal in seconds. Frees up frozen chokes, manifold heat controls, pcv valves and heater valve shafts. *Non-chlorinated. Non-hazardous to atmosphere. Includes snorkel. Misty brand.*

Part Number	Size	Pkg Qty
16-0020B .....	Net wt. 15.5 oz. Aerosol .....	12

***Don't worry about avoiding temptation. As you grow older, it will avoid you.***



## Contact & Circuit Board Cleaner III

**ECONOMICAL TO USE**  
Blasting spray cleans oil, grease, dirt and flux from contacts, printed circuit boards, precision instruments, switches and more. Dries fast and residue free. *Safe to use on plastics, rubber and metal. Non-hazardous to atmosphere. Nonconductive to 25,000 volts. Includes snorkel.*

Part Number	Size	Pkg Qty
16-0110B .....	Net wt. 11 oz. Aerosol .....	12

**WARNING: EXTREMELY FLAMMABLE.** This product should not be used on energized equipment.



## Paint, Gasket & Decal Remover

Versatile! Strips fiber gaskets, silicone gaskets, acrylic paints, varnishes, urethanes, plastic decals and more. Thick gel clings to vertical and overhead surfaces without run-off. Wipe, scrape or flush off with water. May be used on wood without raising the grain. *Non-hazardous to atmosphere. Misty brand.*

Part Number	Size	Pkg Qty
16-0021B .....	Net wt. 14 oz. Aerosol .....	12



## Vandalism Mark Remover

Clings to vertical surfaces. Powerful gel formula dissolves graffiti, spray paints, scuff marks, road tar, inks, crayon and more from road signs, bus seats, rest-room walls and playgrounds. *Misty brand.*

Part Number	Size	Pkg Qty
16-0069B .....	Net wt. 12 oz. ....	12

# Cleaners

## STOCKHAUSEN

*...Keeping Working Skin Healthy*

Stockhausen specialty hand cleaners use skin-compatible ingredients that remove the toughest grease and grime, but are gentle enough to use everyday! Features ASTOPON® natural, biodegradable walnut shell scrubbers. Made in U.S.A.

### KRESTO® EF Extra Heavy Duty Hand Cleaner with Walnut Scrubbers

**Kresto® EF** is an extra heavy duty, low solvent hand cleaner that cuts industrial dirt, grease, oil, soot, ink, sewer sludge, carbon black, lacquers, adhesives and more. Deep cleaning **ASTOPON®** natural, biodegradable walnut shell scrubbers will not clog pipes! Non-toxic, low solvent formula. Contains **EUCORNOL®** for conditioning.



Part Number	Size	Pkg Qty
SH-87005	250ml Tube (7.5 oz.)	24
SH-87045	2000ml Softbottle® (60oz.)	6

### ESTESOL® Light Duty Hand Cleanser

**Estesol®** is a soap-free liquid skin cleanser for light dirt, with strong washing power and very good skin compatibility. Use for everyday hand cleaning. Pleasant to use and economical.



Part Number	Size	Pkg Qty
SH-83311	2000ml Softbottle® (60oz.)	6

### CUPRAN® SPECIAL Heavy Duty Paint & Resin Removing Hand Cleaner with Walnut Scrubbers

**Cupran® Special** is a powerful hand cleaner for oil-based paints, stains, urethane, sealants, adhesives, tar and asphalt. **ASTOPON®** natural, biodegradable walnut shell scrubbers will not clog pipes! Perfect for Body Shops!



Part Number	Size	Pkg Qty
SH-81871	250ml Tube (7.5 oz.)	12
SH-81874	2000ml Softbottle® (60oz.)	6

### Softbottle® Dispenser

Convenient, wall-mountable. Accommodates all 2000ml Softbottles®. Pkg: 1 each.



SH-89806	White
SH-89808	Black

### KRESTO® KWIK WIPES® Waterless Hand Cleaning Towels

**Kwik-Wipes®** are textured for quick, waterless cleaning of dirt, grease and grime from hands. Perfect for when a sink is not available, at individual workstations, or for maintenance fleets. Large 10" x 12" polypropylene towel.

**Part No. SH-87077**



Part Number	Size	Pkg Qty
SH-87077	70-Count Cannister	6





# Cleaners

## Citrus-Based Hand Cleaners

Our most powerful citrus lotion hand cleaner works with or without water. D'limonene based formula removes dirty grime and leaves hands clean and odor free. Gentle to the skin. Fortified with lanolin and emollients to protect hands from chapping. USDA category E-4.



Part Number	Size	Pkg Qty
<b>CITRA CLEAN LOTION, WITH PUMICE</b>		
16-440GL	1 gal. Flat-Top Bottle	4
<b>NATURALLY CLEAN LOTION, SMOOTH</b>		
16-443PT	1 pt. Spout-Top Bottle	12
16-443GL	1 gal. Flat-Top Bottle	4

*One Plastic Pump is included with purchase of every 4 gallons.  
Flat top gallons accept 30-102P Universal Dispenser  
(see next page).*

## GO-JO™ Waterless Hand Cleaners

This powerful hand cleaner quickly emulsifies and removes deeply embedded dirt, grease, oil, tar, putty, cement, glue, asphalt and the most stubborn soils. Cleans with or without water. Fortified with lanolin.



Part Number	Size	Pkg Qty
<b>GO-JO™ ORIGINAL CREME</b>		
GJ-1115	4.5 lb. Plastic Can	6
<b>GO-JO™ CREME WITH PUMICE</b>		
GJ-1135	4.5 lb. Plastic Can	6
<b>GO-JO™ LEMON CREME</b>		
GJ-0905	4.5 lb. Plastic Can	6

*Accepts 30-102P Universal Dispenser (see next page).*

## Multi-Purpose Hand Cleaning Towels



**PRE-MOISTENED HAND CLEANING TOWELS**  
Removes tar, grease, wax, ink, paint, lubricants, glue, rubber gasket and tile cements from hands and nonporous surfaces in your shop. To aid in cleaning, the towels are made from an abrasive yet non-scratching fabric that helps lift away heavy deposits of grime and dirt.

- ✓ Tough on grime—Lifts away tar, grease, adhesives, ink, waxes & lubricants and more.
- ✓ Non-scratching abrasive fabric aids in cutting through stubborn soils.
- ✓ Natural oils and emollients—Will not dry out hands. Safe to use on sensitive hands.
- ✓ No rinsing required—Leaves behind a fresh citrus scent as they clean.
- ✓ Versatile—Cleans dirty hands, faces, tools, benches, sinks, counter-tops, basins, panels and more!
- ✓ Saves time and money—Reduce trips to wash area.
- ✓ Large 10" x 12" towel size comes in a convenient dispenser that is re-sealable to keep out dirt and contaminants.

Part Number	Size	Pkg Qty
30-1009	Large, 130 count	4
30-1007	Medium, 70 count	6
30-1008	Small, 20 count	12

Why is abbreviation  
such a long word?

# Cleaners

## LOCTITE PARR™

### Paint & Resin Removing Hand Cleaner w/Pumice



#### THE SAFE ALTERNATIVE TO HARSH SOLVENTS

A fine pumice lotion formulated to remove paint, polyurethane, stain, varnish, adhesives, plastic pipe cements and other tough soils. Parr® is a safer alternative to harsh thinners and solvents. Ideal for painters, plumbers, and manufacturing finishing operations. Contains skin conditioners: aloe, lanolin, jojoba, and vitamin E. Fresh scent. Non-toxic. Biodegradable.

Part Number	Size	Pkg Qty
LT-65116	14 oz. Bottle	6
LT-65216	1/2 gal. Bottle with Pump	1

LOCTITE



Flat-Top Gallon

Gallon Bottle with pump

Cream Formula

The petroleum-free hand cleaner cuts through the toughest grease and grime with natural citrus oil. Contains aloe, lanolin, and jojoba conditioners. Leaves hands with the fresh scent of oranges! U.S.D.A. approved.

## LOCTITE Blue Label™ Waterless Cream Hand Cleaner



Smooth cream formula that's tough on dirt but gentle on hands. Contains aloe and lanolin. Fresh scent. Fits standard 4.5 lb. can dispensers. U.S.D.A. approved. Loctite brand.

Part Number	Size	Pkg Qty
LT-01013	14 oz. Plastic Can	12
LT-01406	4.5 lb. Plastic Cannister*	6

\*30-102P Universal Dispenser required.

Part Number	Size	Pkg Qty
<b>FAST ORANGE® LOTION WITH PUMICE</b>		
LT-25218	1 gal. Bottle w/ Pump	4
LT-25104	1 gal. Flat-top Bottle	4
<b>FAST ORANGE® LOTION, SMOOTH (WATERLESS)</b>		
LT-23218	1 gal. Bottle w/ Pump	4
LT-23104	1 gal. Flat-top Bottle	4
<b>FAST ORANGE® CREAM WITH PUMICE</b>		
LT-35406	4.5 lb. Plastic Cannister*	6
<b>FAST ORANGE® CREAM, SMOOTH (WATERLESS)</b>		
LT-33406	4.5 lb. Plastic Cannister*	6

\*Cannister accepts 30-102P Universal Dispenser (below).

## Hand Cleaner Dispensers

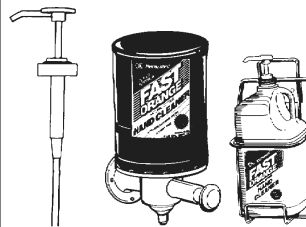

PLASTIC PUMP for one gallon bottles. Part No. 30-221

UNIVERSAL DISPENSER, Wall mountable. Part No. 30-102P

WIRE WALL BRACKET Holds 1 gallon bottle. Part No.30-222



# Cleaners

## Aluminum and Stainless Polish



Cleans, polishes and protects metal in one easy application. Removes tarnish and prevents oxidation. Also works on chrome, gold, platinum, fiberglass and plexiglass. Met-All brand.

Part Number	Size	Pkg Qty
16-0118	Net wt. 2.5 oz. Tube	12
16-0119	Net Wt. 1 lb. Can	6

## Steel Shine Metal Cleaner & Polish

Food-grade mineral oil sprays as a light cream that cleans, polishes and restores luster to all metal surfaces. *Not for tarnish removal.* For use on restaurant fixtures, refrigerators, freezers, stoves, grills, slicing equipment, ovens, preparation tables, elevators, washroom receptacles, water fountains and more. Clings to vertical surfaces. Removes tough oil based stains, water marks, spots and stains of food origin. Leaves a protective coating that resists water-spotting, soiling and fingerprints. Leaves no greasy film. Use on wet or dry surfaces. USDA authorized.



Part Number	Size	Pkg Qty
16-0051B	Net Wt. 18 oz. Aerosol	12

## Floor Sweeping Compound

Absorbs and holds down dust while sweeping work area. Apply compound liberally to dirty floors just before sweeping. Use in maintenance shops, garages and warehouses on wood and concrete floors. *Oil based\**.



Part Number	Size	Pkg Qty
31-706	50 lb. Box	1

*\*Wax based is available on special request.*

## Battery Terminal Cleaner

Foam action cleaner penetrates and emulsifies dirt, grease, acid and contaminants. Neutralizes acid residues increasing the pH to a safe level. Spray liberally on battery, terminals, metal connectors, brackets and nearby areas. Master brand.



Part Number	Net Weight	Pkg
MS-BTC-8	Net Wt. 6 oz. Aerosol	12

## Dri-Rite Absorbent

Premium multipurpose absorbent for cleaning up spilled petroleum products such as oil, hydraulic fluid, and gasoline. Also can be used to provide better traction on icy sidewalks and driveways.



Part Number	Net Weight	Pkg
31-708	40 lb. Bag	1

## Battery Protector

Acid fumes from batteries cause corrosion on nearby metal parts. This corrosion not only shortens the life of these components but can lead to premature battery failure by increasing battery drain. Battery Protector seals battery terminals with a long lasting protective film to eliminate corrosion and extend battery life. Master brand.



Part Number	Net Weight	Pkg
MS-BP-8	Net Wt. 6 oz. Aerosol	12



# Coatings

## Quick-Cote+ Battery Terminal Corrosion Stopper



### NEUTRALIZES ACID

Non-cracking corrosion stopper that neutralizes battery acid and seals electrical connections against corrosion. Brush QuickCote+ on electrical contacts and all areas affected by corrosion. On automotive type batteries, apply to the battery post, terminals, bolts and nuts, cables and hold-down. On light bulbs, apply a thin coat to the base. On flashlights, apply to base of bulb, between battery contacts and on the spring. On battery operated toys, radios, cameras, remote controls, etc., apply to battery contacts and battery to battery connections.

Part Number	Size	Pkg Qty
QC-6023-001	Net wt. 8 oz. Brush-top Can	6

## Battery Terminal Protective Washers

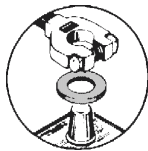

Protective washers made of nonwoven material, impregnated with anti-corrosive inhibitors. Prevents power robbing corrosion build-up on top post and threaded stud battery terminals. 100 per metal can.

Part Number	Color	Pkg Qty
QC-6622-100B	Black	1 can
QC-6622-100R	Red	1 can



## Anti-Spatter and Nozzle Shield

PROTECTS WELDING SURFACES, CONTACTS, NOZZLES  
Non-toxic and nonflammable formula provides a safe welding environment with no harmful fumes. Prevents welding spatter from adhering to mig nozzles, contact tips and related accessories, as well the weld area of metals to be joined. Residual spatter may be brushed or wiped away before painting. Contains no chlorinated solvents or silicone. Ultra brand.

Part Number	Size	Pkg Qty
16-0070B	Net wt. 16 oz. Aerosol	12

## Metal Parts Protector



PROTECTS PARTS FROM CORROSION. SEALS BATTERIES  
Provides long-term protection against rust and corrosion. Flexible, non-tacky and dust resistant. Use on seasonal equipment in storage, batteries, terminals, molds, parts in transit or metal parts to be temporarily sealed against corrosion. In severe storage conditions, two coats should be applied. Temperature range: -40°F to 175°F. Easily removed with solvent. Appearance: yellow paraffin based film.

Part Number	Size	Pkg Qty
16-0050B	Net wt. 14 oz. Aerosol	12

*Warning: Extremely flammable.*

**TIP:** Use heavy wall heat shrink tubing on all exposed connections. Coat exposed battery surfaces and connections liberally with battery terminal protector.

*Stay Bathroom Cleaner.. p.370*



# Coatings

## LOCTITE

### Belt Dressing & Conditioner



Extends belt life. Penetrates the cord fibers of "V" belts to restore pliability and flexibility. Quickly stops belt slippage due to heat, cold, dampness and dust. Eliminates squeaking and glazing.

Part Number	Size	Pkg Qty
LT-30527 .....	Net wt. 12 oz. Aerosol .....	12

*Warning: Not for use on serpentine belts.*

## LOCTITE

### Rubberized Undercoating

SEALS, PROTECTS AND INSULATES

Rust and corrosion inhibitor provides protection against dust, heat, rust, fumes and debris. Durable rubberized shield soundproofs and waterproofs. Remains flexible and won't crack. Ideal for new panel and fender replacements, fender wells or replace chipped undercoating. Color: brown to black film.



Part Number	Size	Pkg Qty
LT-30538 .....	Net wt. 16 oz. Aerosol .....	12

*Warning: Extremely flammable. Do not use in automotive interiors and trunks.*

*tech tip*

*Use Rubberized Undercoating on weld seams, leaky gutters, tree wounds, cracks in driveways. Works great for temporary roof repairs!*

## LOCTITE

### Cold Galvanizing Compound

Spray on metal surfaces to prevent corrosion even when surface is scratched. Ideal touch-up for welded seams. Highly resistant to salt corrosion and water. Resists abrasion and large temperature fluctuations. Uses: trailers, road equipment, farm equipment, ducts, culverts, tanks, pipelines, structural steel, marine equipment and docks, ornamental iron, fences, air conditioners and playground equipment. Contains no ozone depleting compounds. Temperature resistance: Up to 400°F continuous; 600°F intermittent. Color: low gloss grey. Dry time: 15 minutes to touch. *Not resistant to acids or alkaline solutions.* Meets ASTM, MIL and USDA requirements.



Part Number	Size	Pkg Qty
LT-82039 .....	Net wt. 15 oz. Aerosol .....	12

### Red Insulating Varnish

Electrical insulation coating for armature and stator windings, high voltage circuits, commutator ends. Use to restore dielectric properties lost as a result of frictional wear or damage. Resists oils, moisture, acids, alkalies. *Air dries in 10 minutes., cures in 60. Meets class F requirements. Dielectric strength: 2,100 VPM\**



Part Number	Size	Pkg Qty
31-022 .....	Net wt. 15 oz. Aerosol .....	12

*Warning: Harmful vapors (contains methylene chloride.) Extremely flammable. \*Volts per 1 ml thickness.*

# Coatings

**NEW ITEM!**

## MRO High Solids Spray Paint



High solids formulation delivers single-coat hiding power. MRO spray paints offer lowest cost per square foot coverage. *One 20 oz. can of MRO spray paint is equivalent to four 16 oz. cans of most low solids promotional brands.* Using fewer cans of MRO saves you time and money. MRO spray paints tested best in corrosion protection tests. Exceeds ASTM B117 salt solution tests. Best protection against weather, rust, corrosive chemicals, oil, gasoline and rough service. Environmentally safe formula meets stringent U.S. air quality requirements. *20 ounce can, 16 oz. net weight.*

Part Number	Color	Pkg
<b>MRO PAINTS</b>		
SM-620-1411•	Aluminum	6
SM-620-1433•	Flat Black	6
SM-620-1415•	Gloss Black	6
SM-620-1417•	Dark Machinery Gray	6
SM-620-1448	Cascade Green	6
SM-620-1450	Omaha Orange	6
SM-620-1413•	Gloss White	6
SM-620-1443•	New Cat Yellow	6
SM-620-1446	Ryder Yellow	6
SM-620-1427•	Safety Blue	6
SM-620-1452•	Safety Green	6
SM-620-1451•	Safety Orange	6
SM-620-1423•	Safety Red	6
SM-620-1419•	Safety Yellow	6
SM-620-1431•	Light Gray Primer	6
SM-620-1407•	Red Iron Oxide Primer	6

•Available in one gallon cans.

"The key to everything is patience. You get the chicken by hatching the egg - not by smashing it."

- Arnold Glasow

## Spruce 473™ Spray Paint



A full line of low cost, quality primers and finishes that meet your painting needs. This tough, durable paint is perfect for most wood and metal surfaces both indoors and outdoors. Spruce paints are safe to use and do not contain lead, CFC's or chlorinated solvents. Unique concave mixer disc mixes paint even in the bottom rim of the can where common ball mixers can't reach. Extra fine filter eliminates clogging. Full-length tube gets all the product out of the can, and this gives

more coverage. Formulated for use at a distance of 8 to 10 inches from the surface, reducing wasted paint, overspraying and sag. SAG-RESISTANT FORMULA resists sagging, even at cooler temperatures. Non-hazardous to atmosphere. *16 ounce can, 12 oz. net weight.*

Part Number	Color	Pkg
SM-981	Metallic Chrome Aluminum Lacquer	12
SM-9832	Metallic Dull Aluminum Lacquer	12
SM-9810	Flat Black Enamel	12
SM-983	Gloss Black Enamel	12
SM-9824	Semi-Gloss Black Enamel	12
SM-9835	Gloss Dark Blue Enamel	12
SM-9837	Gloss Light Blue Enamel	12
SM-9836	Gloss Brown Enamel	12
SM-9811	Gloss Clear Enamel	12
SM-9831	Gloss Clear Lacquer	12
SM-9814	Metallic Copper Lacquer	12
SM-987	Gloss Dark Machinery Gray Enamel	12
SM-9817	Metallic Gun Metal Gray Lacquer	12
SM-9888	Gloss Bright Green Enamel	12
SM-988	Gloss Dark Green Enamel	12
SM-985	Metallic Gold Lacquer	12
SM-9828	Gloss Orange Enamel	12
SM-984	Gloss Red Enamel	12
SM-9812	Flat White Enamel	12
SM-982	Gloss White Enamel	12
SM-9886	Gloss Dark Yellow Enamel	12
SM-9834	Gloss Light Yellow Enamel	12
SM-9815	Light Gray Primer	12
SM-9826	Red Iron Oxide Primer	12

† Metallic finish

**ALL PAINT COLOR CHARTS AVAILABLE ON REQUEST**



# Coatings

**BIG RIG**  
FOR THE **BIG JOBS!**



## BIG RIG Fleet Spray Paint

Formulated with the heavy duty owner/operator in mind. High solids aerosol ensures single-coat hiding power. Made by the inventor of aerosol spray paint, Seymour of Sycamore, Inc.

- Resists fading, chipping, peeling, cracking and corrosion.
- Each can contains 30% more paint than typical "off-the-shelf" brands.
- Use on wheels, fuel tanks, bumpers, mirrors and trim.

Part No.	Color	Pkg
SM-20-1611	Aluminum, 20 oz.	6
SM-20-1648	Cast Iron, 20 oz.	6
SM-20-1647	Cummins Beige, 20 oz.	6
SM-20-1615	Frame Black, 20 oz.	6
SM-20-1623	Fleet Red, 20 oz.	6
SM-16-266	John Deere Yellow, 16 oz.	6
SM-20-1686	School Bus Yellow, 20 oz.	6
SM-20-1660	Stainless Steel, 20 oz.	6
SM-20-1603	Fleet White, 20 oz.	6

*Color chart available on request.*

## Paint Marking Wand

For use with Stripe® Inverted Marking Paints and most all other brand marking paints. Reduces back strain and maintains consistent marking height. Used by highway crews, utilities, landscapers, athletic departments, golf courses, surveyors and municipalities.

**Part No. 10-726**



## Inverted Marker Paints

Heavy duty water-based industrial marking and striping paints are environmentally formulated.



- **INVERTED TIP MARKER** is a heavy duty water-based up-side-down paint available in a full range of coded construction and public works colors. Comes with protective cap that prevents accidental spraying.
- **TRAFFIC MARKER** is a water based up-side-down paint formulated with high pigment solids suitable for concrete, blacktop, gravel and dirt. Not affected by water.
- **GOLF COURSE MARKER** is a water-based up-side-down paint formulated *not to harm grass*. This marker is not water soluble and will not wash away during rain or irrigation. Comes with protective cap that prevents accidental spraying.

Part No.	Color	Pkg
<b>STRIPE INVERTED TIP MARKER</b>		
SM-20-652	White, 20 oz.	12
SM-20-663	Asphalt Black, 20 oz.	12
SM-20-653	Precaution Blue, 20 oz.	12
SM-20-655	Safety Green, 20 oz.	12
SM-20-670	Alert Orange, 20 oz.	12
SM-20-671	Safety Red, 20 oz.	12
SM-16-676	High Visibility Yellow, 16 oz.	12
SM-16-677	Caution Yellow, 16 oz.	12
SM-20-654	Fluorescent Red, 20 oz.	12
SM-20-657	Fluorescent Orange, 20 oz.	12
SM-20-668	Fluorescent Green, 20 oz.	12
SM-20-669	Fluorescent Blue, 20 oz.	12
<b>TRAFFIC MARKER</b>		
SM-20-642†	Traffic White, 20 oz.	12
SM-20-646†	Traffic Yellow, 20 oz.	12
SM-20-648	Light Handicap Blue, 20 oz.	12
SM-20-649	Dark Handicap Blue, 20 oz.	12
<b>GOLF COURSE MARKER</b>		
SM-16-692	White, 16 oz.	12
SM-16-694	Red, 16 oz.	12

† Also available in solvent base (no broken packages).

*Color chart available on request.*

# Coatings

## Valve-Action Paint Markers

Valve action releases paint as needed. Felt tip makes long-lasting, bold marks on all surfaces -- metal, glass, wood, rubber, paper, cardboard, styrofoam, and fiberglass. Compact size fits in shirt pocket. Durable metal barrel. Lead-free, fade resistant paint. Complete assortment of colors in stock. *Temperature range: -50°F to 150°F. Dries in 3 minutes. Markal brand.*



Part No.	Color	Pkg
10-727	White	12
10-728	Yellow	12
10-737	Red	12
10-738	Black	12
10-739	Orange	12
10-740	Dark Blue	12
10-741	Green	12
10-743	Aluminum	12
10-744	Light Blue	12

## Ball Tip Paint Marker

Durable 1/8" metal ball tip lasts and lasts. Marks both smooth and rough surfaces. Ideal for any hard surface -- metal, glass, wood, plastic, fiberglass, billets, raw steel or semi-finished steel. Marks with fine lines on smooth surfaces, rough surfaces (cast metals) and even wet surfaces. Lead-free, fade resistant paint. *Temperature range: -50°F to 150°F. Dries in 5 minutes. Markal brand.*



Part No.	Color	Size	Pkg
10-729	Yellow	1 oz. bottle	12

## Brush-On Electrical Tape

Great for hard to tape areas. Stays flexible and will not crack or unravel like vinyl tapes. Forms a coating that seals out moisture and corrosion for strong, trouble-free electrical connections. Insulates, waterproofs and protects terminals of all types. Absorbs vibrations, prevents terminal screws from vibrating loose. *Extremely flammable. Color: Black.*



Part No.	Size	Pkg
30-1002	Net wt. 4 oz. Brush-Top Can	12



## H.C.F. (Hard Coat Finish)



### STOPS RUST DEAD IN ITS TRACKS!

HCF is a flexible semi-gloss water base coating that outperforms enamels and latex paints. Can be rolled, brushed or dipped. Exhibits excellent petroleum, chemical, UV, corrosion and abrasion resistance. Typical applications: Metal I-Beams, steel buildings, iron railings, steel posts, snow plows, scraper blades, chassis, tanks, vessels, protecting and color coding transformers, coils, tools, fixtures and brackets, oil handling equipment, heavy machinery, chain link fences; bonds to metal, wood, concrete, and plastics without primers. The safety of water base with the performance of solvent base coatings.

*HCF's very low V.O.C.'s, non-flammable and high solids content make it an Emission Control Coating System, eccs®, that can be air dried or heat cured to meet production demands. Note: Spray formula is available for spray applications as a special order. Clean up with water, mild solvent if allowed to dry.*

### SPECIFICATIONS

**Weather ability** (ASTM G-53) Excellent 7-10 years  
**Temperature use range:** -0°F to 250°F.  
**Viscosity range:** 4,000-10,000cps  
**Finish:** semi gloss  
**Shelf life:** 1 year at 77°F  
**Coverage:** 100 sq.ft. per gallon at 5 mils  
**Dielectric** (ASTM D-149) 1,100 v/mil  
**Chemical resistance:** Petroleum: excellent, Acids, alkalines: good, Alcohols, ketones, chlorinated solvents: limited

Part No.	Color	Size	Pkg
HC-30101	Red	1 gal. can	1
HC-30107	White	1 gal. can	1
HC-30108	Gray	1 gal. can	1
HC-30103	Black	1 gal. can	1

## Rust Stopper



**DISCONTINUED ITEM**

*Replaced by HCF (shown above).*



# Big Foot™ Anti-Slip Coatings

Big Foot™ epoxy flooring products provide tough, long lasting anti-skid surfaces for added safety. Big Foot™ coatings stand up to heavy traffic and harsh environments. All products meet the requirements of USDA for incidental food contact.



**NEW ITEM!**

## Heavy Duty Pedestrian Grade

PEDESTRIAN AND LIGHT ROLLING TRAFFIC

A **single-component** coating for areas with heavy pedestrian or light rolling traffic. Ideal for ramps, walkways, locker rooms, stairs and assembly areas. For use on wood, concrete and metal surfaces. Excellent chemical resistance. *Max. temperature rating: 140°F. Functional cure time: 12 hours.*

Part no.	Pkg.	Coverage	Color
LT-96211	1 gal.	50ft <sup>2</sup>	Black
LT-96261	1 gal.	50ft <sup>2</sup>	Gray
LT-96215	5 Pail	250ft <sup>2</sup>	Black
LT-96265	5 Pail	250ft <sup>2</sup>	Gray

## Acrylic Pedestrian Grade

WEATHER RESISTANT, FLEXIBLE

A **single-component** elastomeric exterior floor and deck coating for optimum adhesion to asphalt and flexible applications where a flexible weather resistant coating is needed. Use on decks, stairs, asphalt, wood, concrete, and metal surfaces. Excellent chemical resistance. *Max. temperature rating: 140°F. Functional cure time: 12 hours. Not recommended for vehicular traffic.*

Part no.	Pkg.	Coverage	Color
LT-95591	1 gal.	70ft <sup>2</sup>	Gray

## Big Foot™ Accessories

Part no.	Description	Pkg
LT-96121	Phenolic Rollers	4
<i>For use with all Big Foot™ anti-slip coatings.</i>		
LT-96153	Bristle Rollers	2
<i>For use with all Big Foot™ primer/sealers.</i>		
LT-96131	Jiffy Mixers	1
<i>For use with all Big Foot™ coatings.</i>		

## Vehicular Grade (Two Part)

HEAVY ROLLING TRAFFIC

Popular **two-part epoxy** coating withstands even the heaviest rolling equipment traffic. Resists liquids as harsh as jet fuels and hydraulic fluids. Superior adhesion form a solid bond to wood, concrete and metal surfaces. Excellent chemical resistance. *Max. temperature rating: 140°F. Functional cure time: 12 hours.*

Part no.	Pkg.	Coverage	Color
LT-96221	1 gal. kit	40ft <sup>2</sup>	Black
LT-96251	1 gal. kit	40ft <sup>2</sup>	Gray
LT-96225	5 gal. kit	200ft <sup>2</sup>	Black
LT-96255	5 gal. kit	200ft <sup>2</sup>	Gray

## Zero V.O.C.

MOST AGGRESSIVE PROFILE, LOW ODOR

This 100% reactive, solvent-free epoxy is low odor and has the most aggressive profile in the Big Foot™ line. Excellent for confined areas, extremely slippery areas and heavy rolling traffic. Use in odor-sensitive areas such as hospitals, wineries, food processing plants. Excellent chemical resistance. *Max. temperature rating: 140°F. Functional cure time: 24 hours.*

Part no.	Pkg.	Coverage	Color
LT-96231	1 gal. kit	40ft <sup>2</sup>	Black
LT-39915	1 gal. kit	40ft <sup>2</sup>	Gray
LT-96235	5 gal. kit	200ft <sup>2</sup>	Black
LT-96245	5 gal. kit	200ft <sup>2</sup>	Gray

## Metal Primer

**Two-part** epoxy-polymide primer increases adhesion between Big Foot™ coatings and metal surfaces.

Part no.	Pkg.	Coverage	Color
LT-96132	1 gal. kit	320ft <sup>2</sup>	Clear

## Acrylic Primer

Single-component, zero V.O.C. primer designed for use with Acrylic Pedestrian Grade coating. Water based.

Part no.	Pkg.	Coverage	Color
LT-95581	1 gal.	250ft <sup>2</sup>	Clear

## Primer / Sealer

Specially formulated to seal all Big Foot™ anti-slip coatings. Use on concrete, wood, tile and porous substrates. Water based. **Pkg Qty: 1 kit**

Part no.	Pkg.	Coverage	Color
LT-94142	1 gal. kit	320ft <sup>2</sup>	Clear

See also "3M Safety Walk Treads" on page 456

# Sealants & Gasketmakers

## LOCTITE

### Hi-Tack Gasket Sealant



Red liquids holds gaskets in place during assembly. Sets quickly to a very tacky film and remains tacky indefinitely. Seals and bonds rubber, cork, paper, felt, metal and asbestos gaskets. Many uses. *Contains no ozone depleting compounds.*

*Temperature range: -65°F to 500°F. Easily removed with lacquer thinner. Color: Red*

Applications: Flange gaskets, hose joints, water pump, oil pump and gear box gaskets, oil pan gaskets, fuel pump gaskets, regulator gaskets, belt anti-slip, cover plates gaskets, threaded connections, terminal protectors, intake manifold, clutch gaskets, differential assemblies, filter line connections, waterproofing spark plugs. Use on studs and bolts to prevent thread corrosion. Also use Hi-Tack to waterproof and protect electrical terminals and wiring.

Part Number	Size	Pkg Qty
LT-30525	1 pt. Brush-Top	12
LT-30526	9 oz. Aerosol	12

## LOCTITE

### Aviation Gasket Sealant

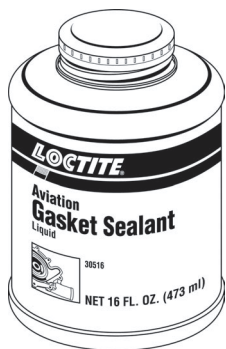

Thin, brushable dressing or sealer for close fitting parts. Slow drying, flexible setting. Resistant to gasoline and other solvents. Withstands pressures to 5000 psi. *U.S.D.A. approved. Tested to MIL-S-45180D. Temperature range: -65°F to 400°F. Color: Black*

Part Number	Size	Pkg Qty
LT-30516	1 pt. Brush-Top	12

## LOCTITE

### Flange Sealant 518 Gasket Eliminator®



Gasket Eliminator® is anaerobic gasket maker for on-the-spot emergency repairs or when a conventional cut gasket is not available. It can be used on a variety of metal surfaces, including aluminum. Forms a flexible, solvent resistant seal that will not tear or decay. Parts disassemble easily even after extended service. Can be removed in minutes with a razor or putty knife. Applications: sealing flexible metal assemblies. Gap fill: .010". Remains flexible. Cures speed: Primed; 30 min. to 4 hours, Unprimed; 24 hours. Temperature range: -65°F to 300°F. Appearance: Red liquid.

Part Number	Size	Pkg Qty
LT-51831	50 ml. Tube	10

## LOCTITE

### Gasket Sealant No. 2

Reliable, paste-like gasket sealant, dressing and coating. Sets slowly to a pliable film best suited for non-rigid, vibrating assemblies. Resistant to gasoline and other solvents. Remains tacky. Cures time: 12 hours. Temperature range: -65°F to 400°F. Withstands pressures to 5000 psi. USDA approved. Tested to MIL-S-45180D Type III. Color: black paste.



Part Number	Size	Pkg Qty
LT-30515	11 oz. Shop Tube	12

*(Replaces Permatex Form-A-Gasket #2)*

# LOCTITE

## RTV Sealants & Gasketmakers



### Superflex™ Blue

#### RTV Silicone Adhesive Sealant

Cures to a tough, flexible rubber. Makes any size or shape "formed-in-place" gaskets that resist shrinking, cracking or migrating. Low volatility. *Fills gaps to .25". Tack free: 30 min. Full cure: 24 hours. Temperature range: -65°F to 500°F. Color: Blue.*

### Superflex™ Red High Temp

#### RTV Silicone Adhesive Sealant

Makes gaskets that resist temperatures to 600°F intermittent. Resists aging, weather and thermal cycling without shrinking, cracking or hardening. *Fills gaps to .25". Tack free: 30 min. Full cure: 24 hours. Temperature range: -75°F to 600°F. Color: Red.*

### Ultra Blue®

#### RTV Silicone Gasket Maker

Excellent adhesion to oily and oil contaminated surfaces. Noncorrosive. Will not harm aluminum. Oxygen sensor safe. Low volatility. *Fills gaps to .25". Tack free: 30 min. Full cure: 24 hours. Temperature range: -75°F to 500°F. Color: Blue.*

### Ultra Copper® High Temp

#### RTV Silicone Gasket Maker

Premium silicone gasket maker that can withstand temperatures to 700°F intermittent. Superior oil resistance. Resistant to most chemicals and solvents. Low odor, low volatility noncorrosive and nonconductive. *Fills gaps to .25". Tack free: 30 min. Full cure: 24 hours. Temperature range: -75°F to 700°F. Color: Copper.*

### Superflex™ Black & Clear

#### RTV Silicone Adhesive Sealant

General purpose sealant for caulking, bonding, insulating or waterproofing. Cures at room temperature to form a tough rubber seal. Will not slump in overhead or vertical applications. Withstands extreme temperature cycling, UV light and ozone. *Cannot be painted. Tack free: 30 min. Full cure: 24 hours. Temperature range: -65°F to 450°F. Color: Black.*

### Instant Gasket

Make reliable gaskets in 1 minute! Return equipment to service immediately when you make leakproof gaskets in just one minute with Instant Gasket. Outperforms pre-cut gaskets. *Noncorrosive. Reaches operating strength 15 psi; one minute. Temperature range: -75°F to 600°F. Color: Black. Meets GM 998-5990, Ford WSE-M4G 323-A6 and Chrysler GF-44-A specifications.*

*(Instant Gasket replaces Permatex "The Right Stuff")*

PART NO.	CONTAINER SIZE	PKG. QTY.
<b>SUPERFLEX™ BLUE RTV</b>		
LT-30560	80ml. Tube	12
LT-30518	12 oz. Shop Tube, Boxed	12
LT-30533	300 ml. Cartridge	10
LT-30541	7.25 oz. Pressurized Can	6
<b>SUPERFLEX™ RED (HI-TEMP) RTV</b>		
LT-59630	80ml. Tube	12
LT-82279	12 oz. Shop Tube, Boxed	12
LT-59675	300 ml. Cartridge	10
LT-30564	7.25 oz. Pressurized Can	12
<b>ULTRA BLUE® GASKETMAKER</b>		
LT-58730	70ml. Tube	12
LT-58775	300 ml. Cartridge	10
<b>ULTRA COPPER® (HI-TEMP) GASKETMAKER</b>		
LT-30542	70ml. Tube	12
<b>SUPERFLEX™ BLACK RTV</b>		
LT-59330	80ml. Tube	12
LT-30563	7.25 oz. Pressurized Can	12
<b>SUPERFLEX™ CLEAR RTV</b>		
LT-59530	80ml. Tube	12
LT-59575	300 ml. Cartridge	10
LT-30562	7.25 oz. Pressurized Can	12
<b>INSTANT GASKET</b>		
LT-30507	7 oz. Pressurized Can	6



# Sealants & Gasketmakers

## RTV Silicone Rubber Adhesive/Caulk



MAKES GASKETS, SEALS, BONDS, INSULATES

100% silicone rubber adheres to metal, glass, wood, rubber, synthetics, ceramics, paper and plastics. Gasket uses include: oil pans, oil pumps, thermostat housings, valve covers, water pumps, transmission parts. Resistance to weather, ultraviolet light, and ozone is excellent. Good chemical resistance to most solvents, oils, organic and inorganic chemicals. Not recommended for continuous use with gasoline, fuel oil, or other hydrocarbon materials. *Temperature range: -85°F to 500°F. (High-Temp Red: -85°F to 650°F.) Tacktime: 15 minutes. Cure: 1 hour. Full cure: 24 hours. USDA approved. Tube size: 10.3 fl. oz. Fits standard caulking guns.*

Part No.	Color	Pkg
16-0000	Blue	12
16-0001	White	12
16-0002	Clear	12
16-0003	Black	12
16-0004	Aluminum	12
16-0006	<b>NEW!</b> Almond	12
31-005†	Red, Hi-Temp	12

## Automatic RTV Silicone Rubber Adhesive



MAKES GASKETS, SEALS, BONDS, INSULATES Industrial strength pressurized dispenser - saves time and product lasts longer. Makes any size or shape gasket instantly. Bonds to most materials. Not recommended for continuous use with gasoline, fuel oil, or other hydrocarbon materials. *Temperature range: -85°F to 500°F. (High-Temp Red: -85°F to 650°F) Tack time: 15 minutes. Cure: 1 hour. Full cure: 24 hours. USDA approved. Net wt. 8 oz. pressurized can.*

Part No.	Description	Pkg
31-006B	Hi-Temp. Super-Red	6
31-007B	Super-Blue	6
31-008B†	Super Black	6
31-010B	Super-Clear	6



### Standard Caulking Gun

For use light to medium consistency caulks and sealants. Features standard ratchet rod and spout cutter. For 10-12 oz. cartridges. Import. **Part No. 21-301**

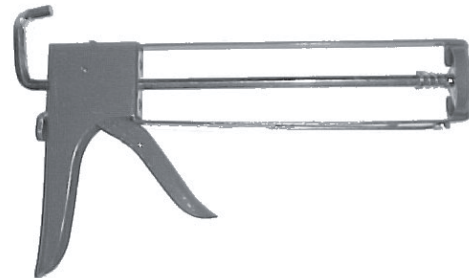

### Professional Caulking Gun

Skeleton frame caulking gun delivers 3 times more thrusting power than standard guns. Easily dispenses stiff caulks and sealants. Features seal puncture tool, spout cutter, heavy duty hex piston rod, quick pressure "thumb" release for fast shut-off. Ladder hook, E-Z load front cap and cartridge retainer spring. For 10-12 oz. cartridges. Import. **Part No. 21-302**

† Meets OEM specifications for use with oxygen sensors.



# Sealants, Gasketmakers & Removers

## LOCTITE

### Chisel® Gasket Remover



Chisel® is a super powerful gasket stripper that dissolves baked on gaskets, carbon deposits, paints, lacquers, adhesives and stubborn deposits from metallic surfaces. Eliminates scraping. Works in minutes. *Contains Methylene Chloride.*

Part Number	Size	Pkg Qty
LT-79040	18 oz. Aerosol	10

### Paint, Gasket & Decal Remover

Dissolves baked on gaskets, carbon deposits, paints, decals shellac, contact cement, burned on oil and grease, tar, asphalt, lacquers, adhesives, and stubborn deposits from metallic surfaces. Eliminates scraping. Works in minutes. Misty brand.



Part Number	Size	Pkg Qty
16-0021B	Net wt. 16 oz. Aerosol	12

### GREAT STUFF™ Expanding Foam Sealant

A minimal expanding foam product that seals cracks, fills holes and insulates. Insulate around drafty electrical outlets and ceiling fixtures. Forms a durable, air-tight and weatherproof bond to wood, metal, glass and most plastics. Dries tack-free in 15 minutes. Cures in 4 hours. *For outside applications, paint or stain the cured foam to protect against UV discoloration.*



Part Number	Size	Pkg Qty
16-0073B	Net wt. 12 oz. Aerosol	12

## tech tip

*Polyurethane foam insulation is extremely difficult to remove. Be prepared by keeping latex gloves and paint thinner on hand. Clean uncured foam immediately with paint thinner, acetone or nail polish remover. Note: Cured foam cannot be removed with solvents or hand cleaners.. If foam hardens on skin, soak area in warm soapy water, then apply petroleum jelly. Foam will wear off in time.*

### Stainless Plumber's Putty (Fixture Setting Compound)

A stainless fixture setting compound for plumbing rims, faucets, strainers, and toilet bowls. Use wherever a nondrying watertight seal is needed. Never hardens, flakes, crumbles, cracks or shrinks.



Part Number	Size	Pkg Qty
30-003	14 oz. Plastic Tub	12

# Lubricants



**LOCTITE**

## Nickel Anti-Seize Lubricant

Copper-free. Recommended for stainless steel and other metal fittings in corrosive environments. Works to 2400°F. Eliminates corrosion, seizing, and galling. Allows easy disassembly of parts.

Part Number	Size	Pkg Qty
LT-77164	1 lb. Brush-Top	10



**LOCTITE**

## Silver Grade Anti-Seize Lubricant

Heavy duty, temperature-resistant, petroleum based lubricant compound fortified with graphite and metallic flake. Inert, will not evaporate or harden in extreme cold or heat. Use in heavy pressure, and corrosive environments. Works to 1600°F. Eliminates corrosion, seizing, and galling. Allows easy disassembly of parts.

Part Number	Size	Pkg Qty
LT-76764	1 lb. Brush-Top	10

## Hi-Temp Anti-Seize Compound Spray



High temperature lubrication for heavy pressure and corrosive environments. Prevents corrosion, seizing, and galling. Use on bearings, slides, fasteners, fittings. Water repellent protective coating extends service life of parts, especially in highly corrosive environments. Temperature range: -60°F to 2100°F.

Part Number	Size	Pkg Qty
16-0025B	Net wt. 14 oz. Aerosol	12



## LOCTITE C5-A® Copper-Based Anti-Seize Lubricant

C5-A® Copper Based Anti-Seize Lubricant is an exclusively formulated colloidal copper compound that in effect "copper plates" mating surfaces. It prevents seizing and galling caused by heavy loads, vibration, corrosion and temperatures up to 1800°F (980°C). For use with most metals under most conditions,

including cast iron, steel, stainless steel, nickel, copper, brass, bronze, titanium, aluminum and monel. Use on bolts, bushings, pipes, fittings, gaskets, headers, lathe ways, manifolds, nuts, packings, press-fits, plugs, screws, studs, threaded surfaces. Reduces friction and wear, speeds assembly and disassembly of parts. **Do not use in oxygen service.** Meets MIL-A-907.

Part Number	Size	Pkg Qty
LT-51005	10 oz. Brush-Top	12



# Lubricants

## Super Lube®

### Long-Lasting Synthetic Lubricant with Teflon®

Synthetic formula with teflon® in suspension lasts 4 times longer than petroleum-based lubricants

Reduce time spent re-lubricating equipment.

Withstands higher temperatures.

Super Lube® will not evaporate or melt.

Reduce lubricant inventories; replaces low-temperature, high-temperature, food grade, bearing and general purpose petroleum-based lubricants.

#### Super Lube® Synthetic-Based Grease

**with Teflon®** Use Super Lube grease in place of these conventional greases; multi-purpose, lithium, bentone, calcium, aluminum complex, high-temperature, low-temperature, electric motor, food grade, bearing, wheel bearing, dielectric, valve sealant and O-ring lubricant. Aerosol Super Lube is ideal for open gears, roller chains and more. Super Lube contains Teflon® for added protection against friction and wear. Non-flammable (aerosol is flammable). *Withstands temperatures from -45°F to 450°F (550°F intermittent).* *Viscosity: NLGI #2 grease. Drop point (ASTM D 556): Non-melt. Timken OK load test (ASTM 2509): 40 lbs. Meets requirements of USDA (H2) for incidental food contact. Color: Translucent white to slightly yellow.*

Part Number	Size	Pkg Qty
LT-82325	3 oz. Tube	12
LT-20029	11 oz. Aerosol	12
LT-82328	14.1 oz. Cartridge	12
LT-82329	1 lb. Can	12
LT-82330	5 lb. Pail	4
LT-82331	30 lb. Pail	1
LT-82357	120 lb. Pail	1

*Warning: Should not be used to replace anti-seize compounds or extreme pressure, high impact and NLGI #4 greases.*



#### Super Lube® Synthetic-Based Oil (10 Weight)

A low viscosity oil that can be used in place of conventional 10 weight oils and general light oil applications. Ideal for misting, dripping, textile spindles, wick feeds, oil cups, enclosed chains, air tool oil, light circulating systems, and as a food grade chain lubricant and rust inhibitor. *Withstands temperatures from -45°F to 450°F (650°F intermittent). 10 weight oil. Non-flammable. Meets requirements of USDA (H2) for incidental food contact. Color: Translucent white to slightly yellow.*

Part Number	Size	Pkg Qty
LT-82337	1 gal. Bottle (10W)	4
LT-82338	5 gal. Pail (10W)	1

*Warning: Should not be used to replace motor oils or transmission fluids.*

#### Super Lube® Synthetic-Based Oil with Teflon® 90-140 Weight Gear Oil.

Use in place of conventional SAE gear grade 90-140 weight "gear box" oil or as a general purpose lube for equipment and machinery. Ideal for plain, anti-friction and roller bearings, enclosed industrial gears, enclosed chains, gearhead motors, paper machines, conveyors and machine tools. *Withstands temperatures from -45°F to 450°F (550°F intermittent). 90-140 weight. Non-flammable. Meets requirements of USDA (H2) for incidental food contact. Color: Translucent white to slightly yellow.*

Part Number	Size	Pkg Qty
LT-82333	1/4 oz. Precision Oiler	12
LT-82334	1 gal. Bottle	4
LT-82335	5 gal. Pail	1

*Warning: Should not be used to replace motor oils or transmission fluids.*



# Lubricants

## Tap Magic® Cutting Fluid



WITH EP-XTRA™ FOR EXTENDED TOOL LIFE  
Use on Tap Magic on any metal cutting operation. Works on all metals... stainless steels, aluminum, titanium, inconel, brass, magnesium, cobalt, monel, copper, nickel, beryllium, bronze, cast irons, molybdenum and more. *Non-hazardous to atmosphere.*

Part Number	Size	Pkg Qty
30-244	4 fl. oz. Spout-top Can	24
30-245	16 fl. oz. Spout-top Can	12
30-246	1 gal. can	2



## LPS Edge Lube™

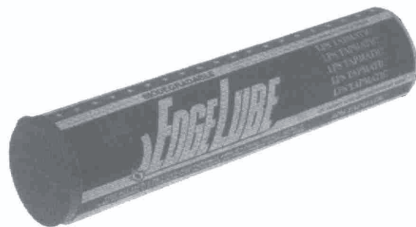

Cutting lube in a solid, white, waxy bar. Excellent for vertical or overhead applications. Use on drills, taps, reamers, grinding wheels, sanding belts, hole saws and band saws. Cools, speeds metal removal, and produces smooth, clean threads. *May be applied before the cutting operation begins, or while tool is in operation. Biodegradable. LPS brand.*

Part Number	Size	Pkg Qty
30-248	Net wt. 13 oz. stick	10

**SAVE WHEN YOU  
BUY IN QUANTITY!**

## Dark Cutting Oil

Finest quality, special purpose sulfur-lard thread cutting oil formulated with petroleum oils and special additives, including an odorless germicide that helps avoid rancidity and skin irritation. Cools, speeds metal removal, and produces smooth, clean threads. Will not congeal at 20°F. Excellent for drilling, turning and other metal cutting operations. Not recommended for lubricating parts.



Part Number	Size	Pkg Qty
16-301GL	1 gal. Bottle	4



## LPS Edge Creme™



Cutting lubricant in a convenient paste form. Use with drills, reamers, annular cutters, hole saws, taps and dies. Excellent for vertical applications. Edge Creme speeds metal removal and produces smooth, clean threads. *Must be applied before the cutting operation begins. May also be used to pre-coat threads, seals and O-rings. LPS brand.*

Part Number	Size	Pkg Qty
30-247	Net wt. 11 oz. Tube	10

## Cutting Fluid Spray

CLINGING FOAM SPRAY  
Nonflammable formula with active sulfur and an extreme pressure additives\* keeps cutting tools sharper under higher loads. Clinging foam will not run or over spray. Snorkel included. Misty brand.



Part Number	Size	Pkg Qty
16-0018B	Net wt. 14 oz. Aerosol	12

*\*Not recommended for use on aluminum or copper.*



# Lubricants

## BruteLube™ Cutting Fluid

### SAFE ON ALL METALS

Effectively extends the life of cutting tools and provides a superior work-piece finish. Specially formulated to cling to cutting tools for a continuous shield against friction and heat. Cutting tools run cooler and last longer, dramatically slashing tool costs. BruteLube™ cutting fluid is especially effective on aluminum, stainless steel, and many exotic alloys. *Complies with O.S.H.A. regulations. Does not contain 1,1,1 Trichloroethane. U.S.D.A. authorized.*



Part Number	Size	Pkg Qty
30-243	16 oz. spout-top bottle	12

## Dry Moly Lube

A dry film lubricant with a very low coefficient of friction for use in extreme pressures or temperatures. Molybdenum disulfide base is inert to water, oil, alkalis and many acids. Coating burnishes to the metal surface without rupturing. Will not attract dust. Applications: roller chains, bushings, conveyors, bearings, pumps, slides, high speed gears. *Temperature range: -110°F to 1000°F. Misty brand.*



Part Number	Size	Pkg Qty
16-0040B	Net wt. 15 oz. Aerosol	12

## Metalworking Coolant

Concentrated synthetic coolant dissolves in water for recirculating mist or flood systems in machine shop production applications. Safe to use on all metals and alloys. Contains special corrosion inhibitors to protect finished work from flash rusting. When diluted with water, it makes a clear solution to give the operator an unobstructed view of the work-piece. *Dilution ratios can be varied for the best economy under various conditions. Does not contain silicone or sulfur. Biodegradable. MPI brand.*



Part Number	Size	Pkg Qty
16-303GL	1 gal. Bottle	4
16-303PL	5 gal. Pail	1

*Also available in 55 gallon drums. Coolant misting systems and nozzle positioners available on request.*

VISIT OUR WEBSITE  
**mpi-online.com**  
 FAX ANYTIME!  
**219-696-6413**

## Dry Graphite Lubricant

### WILL NOT ATTRACT DUST

Penetrates deep to eliminate friction and squeaks. Inert to water, oils, alkalis. Unaffected by temperature extremes. Leaves a protective film of graphite to prevent rust and corrosion. Effective from -100°F to 800°F. Applications: hydraulic pumps, engines, business machines, roller chain, bushings and slides. Total Solutions brand.



Part Number	Size	Pkg Qty
30-065	Net wt. 12 oz. Aerosol	12

## Air Tool Oil

### LIGHT VISCOSITY

A quality pneumatic tool lubricant for manual application or use in automatic lubricators. Light viscosity will not form varnish or sludge in tool. Amflo brand.



Part Number	Size	Pkg Qty
AF-1220-1	1 pt. bottle	12
AF-1220-8	1 gal. Bottle	4

# Lubricants

## Chain & Cable Lube



CONTAINS PTFE AND MOLY  
Designed for cable lubrication in severe climatic conditions, extreme temperatures and pressures. Clinging foam breaks down to a heavy penetrating lubricant that clings to metal surfaces and will not fly off. Will not break down under high temperatures. Penetrates, lubricates and prevents rust. Applications: wire rope, slings, roller chains, emergency brake cables, etc. Misty brand.

Part Number	Size	Pkg Qty
16-0017B	Net wt. 12 oz. Aerosol	12

## Slip-Shot II Hi-Temp Red Grease



The high temperature grease that sprays as a penetrating liquid, then cures fast to a thick red gel that resists extreme temperatures, high impact, and high pressures. Slip Shot II Prevents rust and corrosion and resists water and steam washout. Applications: oven doors, cams, rollers, forklifts, wire ropes, roller chains, fittings, bearings, linkages, etc. Temperature range: -40° to 575° F. Color: red. Misty brand.

Part Number	Size	Pkg Qty
16-0016B	Net wt. 12 oz. Aerosol	12

## Gear & Chain Lubricant



This heavy, waterproof lubricant is designed for continuous coating of open gear and roller chain surfaces. It has a highly tacky consistency for use on open and enclosed gears, chain blocks, sprockets, hoists and wire ropes and lift truck chains. *Color: Black. Misty brand.*

Part Number	Size	Pkg Qty
16-0052B	Net wt. 18 oz.	12

## LOCTITE

### White Lithium Grease

A heavy duty lithium-based grease for use where a visible, water resistant film is required. Aerosol formula cures to a thick grease that resists water wash-out. Prevents rust. Heat resistant to 380°F (dropping point). Use on: chains, linkages, over-head door tracks, bearings, slides, rollers, hinges, sprockets, small gears.



Part Number	Size	Pkg Qty
LT-30543	Net wt. 10.75 oz. Aerosol	12

## LOCTITE

### Hydraulic Jack Oil

Specially formulated hydraulic oil with an anti-wear additive that is noncorrosive, prevents internal rust and corrosion, sludge buildup, preserves seals and improves lubrication. Use in forklift trucks, jacks, motorcycle front forks. Non-foaming. *Temperature range: -40°F to 120°F.*



Part Number	Size	Pkg Qty
LT-30523	1 gal. Bottle	6

## LOCTITE

### Dielectric Grease

Provides a moistureproof barrier that lubricates and protects electrical equipment from salt, dirt and corrosion. High dielectric strength. Good thermal, oxidation and chemical stability. *Temperature resistant to 400°F.*



Part Number	Size	Pkg Qty
LT-30536	.33 oz. Tube	12



# Lubricants



## Multi-Purpose Lithium Grease

Lithium grease has excellent water resistance, mechanical stability and protection against rust, oxidation and corrosion. A petroleum hydrocarbon lubricant for general purpose applications in industrial, automotive, farming, mining, and construction industries. Use on plain and anti-friction bearings, gears and couplings. *NLGI No. 2 density. Color: black.*

Part Number	Size	Pkg Qty
MS-GL-14	Net 14 oz. Cartridge	10y
PW-30-127	3 oz. Cartridge, 3/pkg	1 PKG



SYNTHETIC BASED GREASE WITH TEFLON®. Lasts 4 times longer than traditional petroleum based greases. Won't drip or run. Nontoxic, nonflammable and biodegradable. *NLGI No. 2 density. Temperature range: -65°F to 500°F. USDA category H-1 for use in federally inspected meat and poultry plants. Color: Translucent white.*

Part Number	Size	Pkg Qty
LT-82328	Net 14.1 oz. Cartridge	12

## White Lithium Grease

A multipurpose grease for hinges, locks, latches, battery terminals, switches, shackle pin and spring assemblies, threaded assemblies and more. *Temperature range: -10°F to 265°F. NLGI No. 2 density and softer. Plews brand.*

Part Number	Net Wt.	Pkg Qty
PW-30-140	1 lb. can	12

## Lubriplate® No. 630-2 Multi-Purpose Grease

The ideal multi-purpose high temperature, extreme pressure, water repellent, protective lubricant. Use for general lubrication of industrial, automotive, construction, marine, and farm equipment. *NLGI No. 2 density. Temperature range: 0°F to 350°F. Color: Tan. Lubriplate brand.*

Part Number	Size	Pkg Qty
LP-L0072-098	Net 14 oz. Cartridge	10

## Lubriplate® No. 105 Motor Assembly Grease

Provides anti-wear, anti-seize coating to the internal parts of engines and transmissions. Provides instant lubrication during initial start up before the motor oil has circulated. Also used for lubricating automotive hinges, locks and latches, distributor cams, press fits, battery terminals, switches, . *NLGI No. 0 density. Temp. range: -30°F to 170°F. Color: White.*

Part Number	Size	Pkg Qty
LP-L0034-094	Net wt. 10 oz. Tube	12

## Super Impact Grease

Special additives enable this grease to withstand the heavy impact and pounding pressure common to heavy equipment. Resists spatter and pounding out through the bearing or fitting. Resists water washout from pressure washers. *NLGI No. 2.5 density. Temperature range: 0°F to 550°F. Color: Green.*



Part Number	Size	Pkg Qty
30-999	Net wt. 14 oz. Cartridge	10

## Wheel Bearing Grease

Especially designed bearing lubricant for the high-temperature requirements of all disc and drum brake applications. *NLGI No. 2. LubriMatic brand.*

Part Number	Size	Pkg Qty
30-133	1 lb. can	12



# Lubricants

## Penetrating Lubricant Nonflammable Penetrant

CONTAINS P.T.F.E.

A superior nonflammable penetrant formulated to loosen rust-locked parts on contact. Stops and prevents corrosion saving repair and maintenance time. Fortified with Polytetrafluoroethylene (P.T.F.E.) for long lasting lubricity and rust prevention. Safe to use indoors and on high heat applications. Spray on corroded parts, fasteners, fittings, valves, chains, cables, conveyors, linkages, heat risers, shears, hand tools, hinges and locks.

*Extension tube included. USDA class H-2. Non-hazardous to atmosphere. Misty brand.*



Part Number	Size	Pkg Qty
16-0013B	Net wt. 19 oz. Aerosol	12



## Powerful Penetrating Catalyst

Concentrated copolymer formula is the most effective penetrant available today. B'laster frees rusted bolts, nuts, joints, pipe threads, frozen heat risers and more. Stops rust and corrosion. Lubricates fishing reels, guns and sporting equipment. Restores life to rubber seals and "O" rings. Displace moisture and does not evaporate—spray inside distributor to start wet engines. Makes and excellent bug & tar remover too! Used by the US Navy, Army Corps of Engineers, Air Force, major steel companies, and more. *Pin-point spray (no extension tube needed!). Sprays upside down and in all directions. Non-hazardous to atmosphere. Can degrade some plastics and styrenes. Extremely flammable.*



Part Number	Size	Pkg Qty
15-706	13.26 oz. net wt. Aerosol	12
15-705	1 gal. can (128 fl. oz.)	4

## Moisture Guard Multipurpose Lubricant

CONTAINS P.T.F.E.

Penetrates, lubricates, stops corrosion and displaces moisture all in one product. Long lasting protective coating repels moisture and prevents corrosion for long periods of time. Ideally suited for numerous automotive, truck, agricultural, aircraft, marine and industrial applications. Fortified with Polytetrafluoroethylene (P.T.F.E.) for extra lubricity and rust prevention. Use on rust-locked parts fasteners, fittings, valves, chains, cables, linkages, hand tools, hinges and locks, moving parts, wet electrical components and distributors, lamp sockets and more. *Conforms to mil. specs MIL-C-23411 for corrosion prevention. Extension tube included. USDA class H-2. Non-hazardous to atmosphere. Misty brand.*



Part Number	Size	Pkg Qty
16-0014B	Net wt. 19 oz. Aerosol	12

## WD-40 Multi-Purpose Lubricant

Lubricates, cleans, protects, penetrates and displaces moisture. Stops squeaks and frees sticky mechanisms. Leaves no messy, gummy residue. Dries out electrical and electronic equipment. Use on corroded parts, fasteners, fittings, valves, chains, cables, linkages, hand tools, hinges and locks. *Non-hazardous to atmosphere. Silicone-free. Extension tube included. Extremely flammable. USDA authorized H-2.*



Part Number	Size	Pkg Qty
30-115	Net wt. 12 oz. Aerosol	12
30-116	1 gal. can (128 oz.)	4



# Lubricants



## **LOCTITE** **Solvo-Rust®** **Super Penetrating Oil**

Solvo-Rust® is a super penetrating rust inhibitor that works quickly to free rust-locked part and keep them lubricated and protected from rust. This powerful product may be applied on or near moving parts. Loosens rust, tar, grease, dirt, carbon deposits and corrosion. Cleans metal parts and lubricates to prevent rust. Use on vises, tools, lathes, stays, pulleys, locks,

hinges, appliances, nuts, screws, industrial, utility and marine equipment. *Will not harm painted surfaces. Extension tube included. Extremely flammable.*

Part Number	Size	Pkg Qty
LT-81252 .....	13 oz. ....	12

## **NUTS OFF® Penetrant**



Our most economical 3-in-1 lubricant. Loosens everything rusted or corroded and it works especially well on salt water corrosion. Penetrates close fitting parts on contact. Cleans and removes light rust. Spray on corroded parts, fasteners, fittings, valves, chains, cables, linkages, hinges and more. *Will not harm painted surfaces. Extremely flammable.*

Part Number	Size	Pkg Qty
30-239 .....	Net wt. 11 oz. Aerosol .....	12

## **SUPER-TEF** **Synthetic** **Lubricant** **with Teflon®**



Super-Tef is an exclusively formulated synthetic-based lubricating oil with Teflon® particles held in suspension. Teflon® fills surface irregularities forming a smooth, waterproof, lubricated surface. Lasts up to 4 times longer than similar petroleum based lubricants.

**FIVE PRODUCTS IN ONE!** Super-Tef is a super penetrant, moisture displacer, corrosion inhibitor, solvent cleaner that removes light surface rust and tar, and a cutting fluid for drill bits, taps and other cutting operations. Super-Tef leaves a protective shield that rejects dirt, ice, salt, acids, alkalis, rust, water and weather. Applications: pulleys, hinges, locks, lathes, linkages, clutch and brake cables, garage door tracks, drive chains, motorcycle chains, valves, air tools, conveyors, engine cylinders, cutting tools, hand tools, vises, appliances and more. Use it on practically anything that moves! Safe to use on metal, rubber, plastic, wood, fabric and painted surfaces. **ADJUSTABLE SPRAY VALVE** has low, medium and high setting for desired volume of spray. *Non-hazardous to atmosphere. Will not harm painted surfaces. Extension tube included. Extremely flammable. Color: clear. Pleasant fragrance.*

Part Number	Size	Pkg Qty
30-990 .....	Net wt. 11 oz. Aerosol .....	12

Liberty means  
responsibility.  
That's why most  
men dread it.

# Lubricants

## Textile Grade Silicone Spray

USDA ACCEPTED  
 on-staining dry silicone that  
 leaves no greasy mess.  
 Excellent to waterproofing  
 ignitions and plug wires. Stops  
 noisy squeaks, stops drawers  
 and windows from sticking.  
 Lubricates rubber, glass, metal,  
 plastics, fabrics, zippers,  
 battery terminals, padlocks,  
 windows, door hinges, hand  
 tools, etc. *Non-chlorinated.*  
*Non-hazardous to atmosphere.*  
*USDA accepted (H1) dry*  
*lubricant for food processing,*  
*handling and packaging*  
*equipment found in dairies,*  
*meat rooms, poultry plants,*  
*bakeries, and canneries.*



Part Number	Size	Pkg Qty
16-0061B	Net wt. 11 oz. Aerosol	12

## All-Purpose Silicone Lubricant

AUTOMOTIVE GRADE  
 A thick viscosity silicone  
 formulated to provide superior all  
 purpose lubrication and  
 protection without the use of  
 ozone depleting chlorinated  
 solvents. Use this product on  
 moving parts, as a water and  
 weather barrier, as an electrical  
 insulator, and to prevent sticking  
 squeaking and freezing of doors,  
 windows, locks and assemblies.  
 Safe for use on virtually any  
 surface. Use on rubber, metal,  
 plastics, or wood. *Meets or*  
*exceeds current California*  
*V.O.C. requirements. Non-*  
*chlorinated. Non-hazardous to*  
*atmosphere. Misty brand.*



Part Number	Size	Pkg Qty
16-0027B	Net wt. 11 oz. Aerosol	12

## Economy Silicone Lubricant

TEXTILE GRADE  
 Medium viscosity silicone  
 formulated to provide excellent  
 all around protection and  
 lubrication. Protects and  
 restores any rubber, plastic  
 and vinyl parts with periodic  
 coatings. Will not freeze or  
 melt. Not affected by oil or  
 water. Ideal for textile  
 applications such as cutting  
 tables, sewing needles, knives  
 and cutters. Also used by  
 schools, hospitals, bus  
 garages, auto detailers and  
 maintenance shops.  
 Misty brand.



Part Number	Size	Pkg Qty
16-0114B	Net wt. 11 oz. Aerosol	12

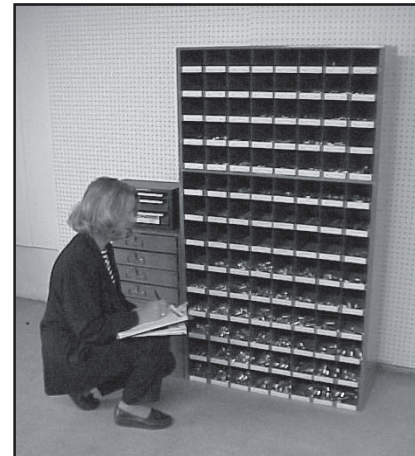

**DON'T RUN OUT OF STOCK!**

Call MPI for  
 inventory service!!



# Miscellaneous Chemicals

## LOCTITE

### Fixmaster® Pipe Repair Kit

#### FOR RELIABLE, TEMPORARY REPAIRS OF PIPES

Restore pipeline to service in 1 hour! Can be used to repair metal, plastic and composite pipes, joints, valves and vessels in 3 easy steps. Urethane-impregnated fiberglass tape, activated by water. Two kits available; both include fiberglass tape, Metal Magic Steel™ epoxy stick, gloves and instructions. Cures in 30 minutes. Max. temperature resistance: 250°F. Tape color: neon yellow. Meets requirements of USDA for incidental food contact. NSF approved, Standard 61. *Should not be used on a pipeline that is carrying caustic, hazardous or otherwise harmful materials.*



Part Number	Kit Size	Pkg Qty
LT-96321	2" X 6 FT	6
LT-96322	4" X 12 FT	6

#### HOW IT WORKS

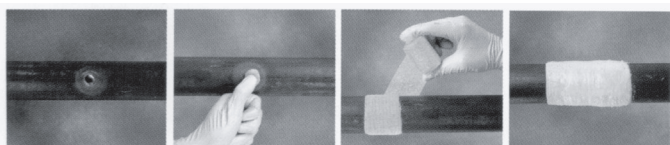

**1. Clean and prep the area.** Turn off pressure in the pipeline and dry the area to be repaired. Then abrade the pipe with sandpaper or file to achieve a rough profile and clean the surface with an oil-free solvent.

**2. Apply epoxy putty.** Wearing gloves supply with the kit, mix and knead the epoxy stick until it is uniform in color. Press the mixed epoxy firmly into the crack, hole or void.

**3. Apply pipe repair tape.** With gloved hand, activate the pipe repair tape by dipping into water for 20 seconds and apply around the damaged area, extending several inches beyond the repair. Keep working the urethane back into the tape while molding and pressing the tape against the surface until it has lost its initial tackiness. Set time @ 50°F - 80°F is 3 to 4 minutes. **Pipe repair will be fully hardened in approximately 30 minutes and the pipe can be returned to service in 1 hour.** *Note: cure time is affected by temperature and thickness of application.*

## LOCTITE

### Clover® Lapping and Grinding Compound



Use Clover® machining compounds for final finishing of metal surfaces not practical with mechanical methods. Silicone carbide grease mix is the standard abrasive paste for fast metal removal. It produces a smooth, flat surface but not a polished one. Leaves a rust-preventing film on lapped surfaces. Meets requirements of USDA for incidental food contact. NSF approved, Standard 61.

- COARSE:** Initial cut, fast metal removal.
- MEDIUM:** General purpose, controlled metal removal.
- MEDIUM FINE:** Cylinder lapping.
- FINE:** Valve lapping, bearings, dies and gauges.
- VERY FINE:** Polishing and lapping,

#### Container size: 1 lb. cans

Part Number	Grit	Pkg Qty
LT-39452	120 Coarse	6
LT-39439	180 Medium	6
LT-39413	240 Med-Fine	6
LT-39510	320 Fine	6
LT-39549	600 Very Fine	6

*Also offered in a wide variety of grits from 36 (very coarse) to 1200 (extremely fine). Container sizes also available are 7 lb. (4 per case), 25 lb. and 100 lb.*

VISIT OUR WEBSITE  
[mpi-online.com](http://www.mpi-online.com)  
 FAX ANYTIME!  
**219-696-6413**

# Miscellaneous Chemicals

## Pro Formula Engine Starting Fluid



Start engines fast, even in temperatures down to -65°F. Contains twice the Ether content of ordinary starting fluids for twice the starting power. Contains upper cylinder lubricant to help protect your engine during starting. Use on gasoline or diesel engines. Master brand.

Part Number	Size	Pkg Qty
MS-SFP-16	Net wt. 11 oz. Aerosol	12

*Note: Starting Fluid is now "UPS-able" without additional hazardous shipping charges.*

## Disc and Drum Brake Fluid



Heavy duty DOT 3 rated fluid for disc and drum brakes. Meets or exceeds SAE J1703, Fed. Specs VVB-680. Master brand.

Part Number	Size	Pkg Qty
MS-FF168	1 gal. Bottle	4

## Carpet & Room Deodorizer



Pleasant vanilla scent. Use everytime you vacuum to eliminates problem odors in carpeting. For all types of carpeting. Destroys odors naturally with baking soda. Also use to freshen litter boxes, diaper pails, upholstery, cars, etc. Package in shaker can.

Part Number	Size	Pkg Qty
31-724	Net wt. 20 oz. Shaker Can	12

## Gas Line Antifreeze & Fuel Dryer



Prevents gas line freeze-ups and stalling. Use year-round to de-water fuel system. Absorbs moisture for smoother engine performance. Contains methanol. Master brand.

Part Number	Size	Pkg Qty
MS-GA-12	Net wt. 12 oz. Bottle	24



# Miscellaneous Chemicals

## Windshield Washer Ready Mix



Ready-to-use cleaning solvent protects to -20°F. Vehicle defroster must be operating when used during freezing temperatures. Contains methanol.

Part Number	Size	Pkg Qty
16-0098 .....	1 gal. Bottle (128 oz.).....	4

## Windshield Spray De-Icer



Melts frost, ice, and snow from auto glass and mirrors for safe winter driving. Great for thawing frozen locks, doors, and headlights too! Harmless to automotive finishes. Master brand.

Part Number	Size	Pkg Qty
MS-WD-16 ...	Net wt. 11.5 oz. Aerosol .....	12

## LOCK-THAW® Lock Deicers



Frees frozen locks. Lubricates and protects all types of locks from freezing and sticking. Penetrates to working parts. Gold Eagle brand.

Part Number	Size	Pkg Qty
31-713 .....	1 oz. Plastic Bottle .....	24
31-714 .....	5/8 oz. Pressurized Can .....	12

## Propane Fuel Cylinders



Brand name product fits standard burners, propane torches, lanterns, stoves, etc. Disposable steel cylinder contains grade HD-5 propane per NGPA standards.

**NOTE: THIS ITEM CANNOT BE SHIPPED VIA U.P.S.**



Part Number	Size	Pkg Qty
30-242 .....	14.1 oz. Cylinder .....	12



# Miscellaneous Chemicals

## Dualcide Insect Spray

EXCELLENT FOR RESTAURANTS AND SCHOOLS  
A powerful insecticide combining two synthetic pyrethroids giving rapid knockdown and kill of most *flying and crawling insects* including flies, cockroaches, fleas, brown dog ticks, mosquitoes, ants and crickets. Odorless formula is ideal for schools and restaurants. Can be sprayed at anytime, even while school is in session. E.P.A. registered.



Part Number	Size	Pkg Qty
31-015B	Net wt. 16 oz. Aerosol	12

## ENFORCER<sup>®</sup> Wasp & Hornet Killer

BLASTS UP TO 22 FEET!  
The wasps are killed before they hit the ground. Ideal for condo's, apartment buildings, utilities, cable companies, power plants and tree trimmers. Outdoor use only. Nonconductive to 28,000 volts. EPA registered.



Part Pkg Number	Size	Qty
16-0113B	Net wt. 18 oz. Aerosol	12

## OFF!<sup>®</sup> Insect Repellent

ORIGINAL FORMULA  
Provides hours of effective protection from mosquitoes, biting flies, gnats, ticks, chiggers and fleas. Won't stain clothing\* and resists perspiration. 360° valve allows spraying upside down. Unscented.



Part Number	Size	Pkg Qty
31-718	Net wt. 6 oz. Aerosol	12

# Accessories



## 9" Paint Roller Covers

Economical and disposable. 3/8" nap thickness for use on smooth or semi-smooth walls. 9" in length. 100% polyester with phenolic core. Use with latex paints only. Pkg: 24 each (shipped in twin packs) **Part No. 17-073**

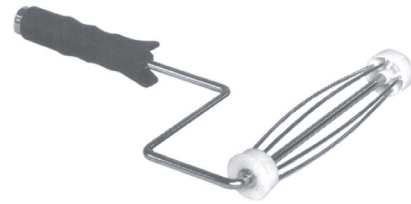

## 9" Paint Roller Frame

For standard 9" rollers covers. Durable 5 wire cage. Pkg: 10 each. **Part No. 17-074**



## Galvanized Paint Tray

For 7" and 9" rollers. Standard galvanized steel 2 quart capacity. Rust retardant. Pkg: 10 each. **Part No. 17-075**

## Plastic Tray Liner

(Not pictured) Black plastic liner makes cleanups easy. Fits in paint tray above. Pkg: 10 each. **Part No. 17-076**



## Painter's Mitt

Can be used with all types of paint. Lint-free synthetic glove with protective plastic liner. Use on fences, railings, pipes and hard-to-reach areas. Pkg: 10 each. **Part No. 17-077**



# Accessories



## Trigger Sprayers

Plastic trigger sprayer with adjustable nozzle and graduation marks on bottle. Leakproof model equipped with a Viton® seal for resistance to mild corrosives and solvents.

Part Number	Description	Pkg Qty
31-019 .....	16 oz. Plastic Sprayer .....	12
31-020 .....	32 oz. Plastic Sprayer .....	12
31-021 .....	32 oz. Leakproof Plastic Sprayer .....	12

## Barrel Pump

USE WITH PETROLEUM BASED LIQUIDS ONLY

Steel head, curved spout is removable for garden hose attachment. Brass valve, steel cylinder, bung adapter. Fits all standard 15 to 55 gallon drums. *Not for use with water-based liquids.* **Part No. 12-55017**

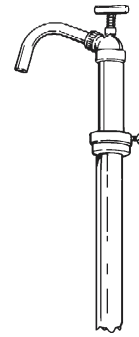

## Rotary Barrel Pump

FOR LIGHT VISCOSITY PETROLEUM BASED LIQUIDS

Rotary handle pumps product in both directions. Bung adapter. Cast iron head, steel tubes. Fits all standard 15 to 55 gallon drums. Pumps approx. 1 gal. per 18 revolutions. *Not for use with water-based liquids.*

**Part No. 12-081**

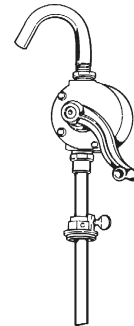

## Disposable Latex Gloves

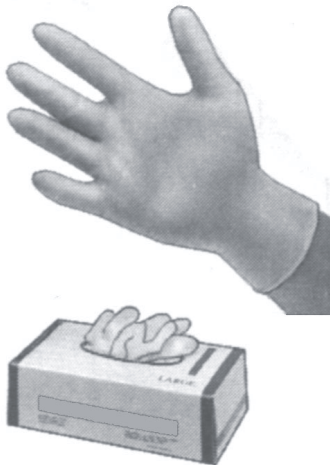

Ambidextrous, lightly powdered. Not for medical use. Color: white. 100 count dispenser package. Imported.

Part No.	Size	Unit
23-400 .....	Small .....	1 pkg
23-401 .....	Medium .....	1 pkg
23-402 .....	Large .....	1 pkg
23-403 .....	Extra-Large .....	1 pkg

## Brake Fluid Pump

FOR LIGHT VISCOSITY PETROLEUM BASED LIQUIDS

Fits standard one gallon cans. Dispenses brake fluid at approximately one ounce of fluid per stroke. Comes complete with 36" flexible tubing with check valve in metal nozzle. Also used for penetrating oil, model airplane fuel, air tool oil and other petroleum based liquids. *Not for use with water-based liquids.*

**Part No. 12-70060**

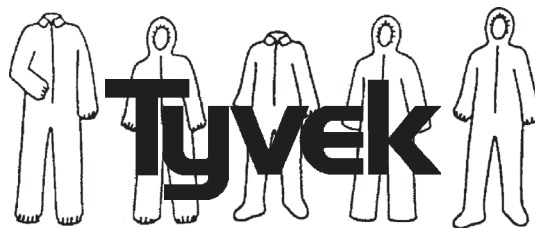
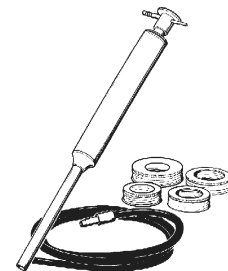

## POLYOLEFIN COVERALLS

**NOW IN STOCK! SEE PAGE 419**



# Accessories

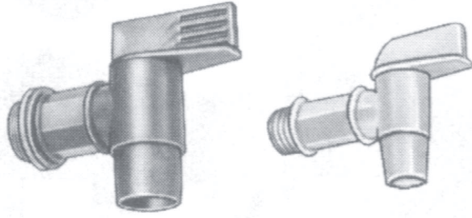

## Polyethylene Barrel Faucet

Manual closing lever handle. Use with most acids, caustics, and oils.

Part Number	Description	Pkg Qty
30-268	2" NPT Jumbo Faucet	1
30-269	3/4" NPT Standard Faucet	1

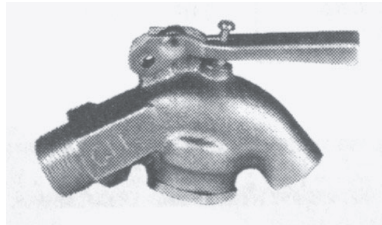

## Bronze Barrel Faucet

Self-closing (normally closed position). Cast bronze body, bronze mesh internal screen and Teflon® seat. Size: 3/4" NPT male thread. **Part No. 12-082**

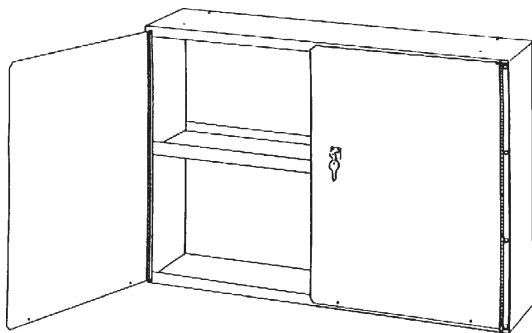

## Aerosol Storage Cabinet

Divided into four sections. Includes lock and two keys. Easily wall mounted using keyholes provided. Gray baked enamel finish. Size: 34"W x 22"H x 8-1/2"D. Shipping wt. 45 lbs. **Part No. 98-343**



## Polyethylene Sprayers & Repair Parts

Strong handle that locks in place and spray wand snaps on handle for storage. Tank is translucent-- easy to see liquid level. Easy to pump up. Adjustable nozzle from mist to long range. Funnel top for easier filling. Includes no-kink hose and instant on/off control valve. Use for insecticides, weed killers, disinfectants, degreasers, furniture/rug protectants, wallpaper remover, etc..

Part Number	Description	Capacity	Pkg Qty
29-475	Standard Sprayer	3 gallons	1
29-476	Lightweight Sprayer	1 gallon	1

### SPRAYER REPAIR KITS

**Pump Maintenance Kit** - Rubber parts and seals for pump for 29-475 and 29-476 sprayers. **Part No. 29-477**

**Spray Wand/Valve Kit** - Control valve, spray wand and handle for 29-475 and 29-476 sprayers. **Part No. 29-478**

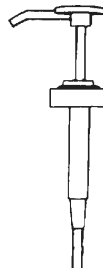

## Pump Dispenser

Fits most one gallon jugs and flat-top bottles. Use with lotions, soaps, and hand cleaners. Pkg: 1 each **Part No. 30-221**

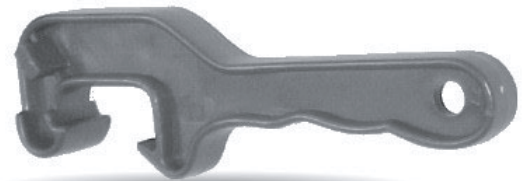

## Plastic Pail Opener

This handy tool easily removes the plastic lids from pails. Works just like a bottle opener. **Part No. 30-271**



# Material Safety Data Sheets Available

Material Safety Data Sheets (MSDS) are available on any products whose contents (whole or in part) may be considered as potentially hazardous, toxic, or potentially injurious to health. Under "The Worker's Right To Know Act", Maintenance Products will make available on request, Material Safety Data Sheets for chemical products and welding alloys you purchase from us. To obtain MSDS information, call us anytime at (219) 696-6411, (800) 523-2367 or fax us at (219) 696-6413. Write to; MAINTENANCE PRODUCTS, INC., PO BOX 368, LOWELL INDIANA, 46356-0368.

---

## Other Name Brand Chemicals

Many other name brand chemical products are available. Some items may be subject to minimum case quantity orders. We have listed some of these brands below. For availability of any chemical product not listed in this catalog, please feel free to contact your MPI representative or our customer service department.

**3M Automotive • Master Chemicals • Crown Industrial • Duro (adhesives)  
Ortho • Gold Eagle • CRC Chemicals • STP (lubricant, fuel additives)  
Solder-Seal (Gunk) • Slick 50 • Prolong • Berryman Chemicals (solvents) •  
Siloo Chemicals (airbrake products) • Mothers' Polishes • Turtle Wax •  
Blue Coral • Armor All • Simple Green • Krylon • W. K. Westley • Bondo  
Camel (tire repair products) • Anti-Borax (welding compounds)  
American Grease Stick • DAP (caulking) W.W. Henry Co. (flooring adhesives)  
Blue Lustre (carpet products) • More!**

---

### IMPORTANT NOTICE

## Shipment of Hazardous Chemicals

You will find some chemical products in this catalog contain acids, flammable gases or other hazardous ingredients. These cataloged items are clearly marked **CANNOT BE SHIPPED VIA UPS**. We cannot deliver these products due to strict and expensive United Parcel Service hazardous shipping regulations. We have other options for delivery of hazardous products as follows: A) We can ship product via **common carrier** in large quantities or along with a large order of merchandise, or B) You can pick up hazardous product at our warehouse located in Lowell, Indiana. For further information please contact your MPI representative or our customer service department at anytime.



## Automotive Body Clips IN STOCK!



Over 14,000 specialty  
automotive clips and  
screws in stock!

Ask your MPI Sales  
Representative or call us  
for a FREE CATALOG!

# Production Arc Welding Electrodes

## AWS E6011 ELECTRODES

- FOR WELDING CARBON STEELS
- DEEP WELD PENETRATION
- WELDS DIRTY OR CONTAMINATED STEELS
- WELDS PIPE • FLUX COATED

**FOR GENERAL PURPOSE** fabrication and maintenance welding. Low **SPATTER**, smooth arc, and improved deposition rate. Capable of X-ray quality welds out-of-position. **PIPE WELDING**; cross country, in-plant, and noncritical small diameter pipes. **SHEET METAL** edge, corner, and butt welds using electrode negative polarity. **VERTICAL UP AND OVERHEAD PLATE WELDING** with vertical down operation particularly outstanding. Joints requiring deep penetration such as square edge butts. Best choice on dirty, oil soaked, greasy, painted, plated, galvanized steels. Weld quality may be lower than on clean steels.

**"Fast Freeze" Characteristics:**

Positions: all, particularly good for vertical and overhead  
 Appearance: flat bead profile with distinct ripples  
 Penetration: deep  
 Slag: light, with little slag interference for easy arc control  
 Polarity: AC (recommended) or DC±  
 AC current range (amps): 3/32" 50-85, 1/8" 75-120  
 DC± current range (amps): 3/32" 40-75, 1/8" 70-110  
 Tensile strength: 68-82,000 psi  
 Hardness, Rockwell B (avg): 78-87  
 Classification: AWS E6011, MIL-G-6011  
**Conformances:**  
 Test requirements of AWS A5.1 & ASME SFA5.1.  
 ASME Boiler Code F3  
 American Bureau of Shipping & U.S. Coast Guard approved.  
 Military Specifications MIL-QQE-450  
 Certificate of Conformance to AWS classifications available for Federal Highway Administration projects.

Part No.	Dia.	Wt./Pkg (lbs)	Order Qty
21-400	3/32	5	1 Pkg
21-401	3/32	50	1 Pkg
21-402	1/8	5	1 Pkg
21-403	1/8	50	1 Pkg

## AWS E6013 ELECTRODES

- FOR WELDING CARBON STEELS
- EXCELLENT FOR LOW VOLTAGE AC WELDERS
- FAST FILL FOR POOR FIT-UPS
- EASY TO USE • FLUX COATED

**FOR GENERAL PURPOSE WELDING** on new or clean sheet metal or heavy gauge steels. Most widely used downhill or in the level position. Stable, easy to handle arc. Smooth, ripple-free bead appearance. **DOWNHILL FILLETS AND LAPS. IRREGULAR OR SHORT WELDS** that change direction or position. Sheet metal lap and fillet welds. Intended primarily for sheet metal welding when superior bead deposit appearance and easy operation are more important than speed. **FAST FILL JOINTS** with poor fit-ups. Excellent for AC operation. Shaft build-up, general fabrications, machine parts and metal buildings.

**"Fill Freeze" Characteristics:**

Positions: All position capable but most widely used downhill or in the level position.  
 Medium deposit rates.  
 Appearance: convex profile. Appearance ranges from smooth and ripple-free to even with distinct ripples.  
 Penetration: medium  
 Slag: medium-heavy  
 Polarity: AC or DC± (DC- recommended\*)  
 AC current range (amps): 3/32" 75-105, 1/8" 110-150  
 DC± current range (amps): 3/32" 70-95, 1/8" 100-135  
 \*Use DC- for best performance on all applications except where arc blow is a problem. To control arc blow, use AC .  
 Tensile strength: 67-74,000 psi  
 Hardness, Rockwell B (avg): 78-84  
 Classification: AWS E6013, MIL-6013  
**Conformances:**  
 Test requirements of AWS A5.1 & ASME SFA5.1.  
 ASME Boiler Code F2, A1  
 American Bureau of Shipping & U.S. Coast Guard approved.  
 Military Specifications MIL-QQ-E-450  
 Certificate of Conformance to AWS classifications available for Federal Highway Administration projects.

Part No.	Dia.	Wt./Pkg (lbs)	Order Qty
21-404	3/32	5	1 Pkg
21-405	3/32	50	1 Pkg
21-406	1/8	5	1 Pkg
21-407	1/8	50	1 Pkg

## AWS E7018 ELECTRODES

- FOR WELDING CARBON & ALLOY STEELS
- LOW HYDROGEN • X-RAY QUALITY, CRACK RESISTANT WELDS • WELDS THICK SECTIONS
- ALL POSITIONS • IRON POWDER FLUX COATING

**ALLOY STEELS** that require 70,000 psi tensile strength deposits. **WELD THICK SECTIONS AND RESTRAINED JOINTS** on mild and alloy steel plate when shrinkage stresses tend to cause weld cracking. To resist cracking in medium to high carbon steels, hot short cracking in phosphorus bearing steels, and porosity in sulfur bearing steels. **LOW HYDROGEN** - Can produce dense, x-ray quality welds with excellent notch toughness and ductility. The low hydrogen content in the deposit reduces the danger of under-bead and micro-cracking on high carbon and low alloy steels and on thick welds. Less preheat is needed than for other electrodes.

**MULTIPLE PASS, VERTICAL AND OVERHEAD WELDS** in carbon steel plate. **IRON POWDER COATING** provides higher deposition rates consistent with out-of-position welding.

**"Fill Freeze" Characteristics:**

Positions: All position operation. Outstanding for vertical and overhead.  
 Weld metal freezes rapidly even though the slag remains relatively fluid.  
 Medium deposit rates provided by iron powder coating.  
 Appearance: flat or slightly convex profile with distinct ripples with little spatter.  
 Penetration: deep  
 Slag: moderately heavy, easy to remove.  
 Polarity: DC+ reverse (recommended) or AC  
 DC+ current range (amps): 3/32" 70-100, 1/8" 90-150  
 AC current range (amps): 3/32" 80-120, 1/8" 110-170  
 Tensile strength: 72-86,000 psi  
 Hardness, Rockwell B (avg): 83-90  
 Classification: AWS E7018, MIL-7018  
**Conformances:**  
 Test requirements of AWS A5.1 & ASME SFA5.1.  
 ASME Boiler Code F4, A1  
 American Bureau of Shipping & U.S. Coast Guard approved.  
 Military Specifications MIL-E-22200/1  
 Certificate of Conformance to AWS classifications available for Federal Highway Administration projects.

Part No.	Dia.	Wt./Pkg (lbs)	Order Qty
21-408	3/32	5	1 Pkg
21-409	3/32	50	1 Pkg
21-410	1/8	5	1 Pkg
21-411	1/8	50	1 Pkg

# Maintenance Arc Welding Electrodes

## SUPER-ALLOY

ALL-PURPOSE, HIGH STRENGTH FOR ALL TYPES OF STEEL. THE POPULAR "DO-TO-ALL" WELDING ROD!

The ultimate all-purpose electrode is specially formulated for welding virtually all types of steel. Low and medium carbon steel, high alloy steel, stainless steel, dissimilar thicknesses and materials. Solves common metal joining problems. Weld tool steel, railroad and construction equipment. Use in all positions.

Current ..... AC/DC±  
 Tensile Strength as welded ..... up to 115,000 psi  
 Tensile Strength work hardened ..... up to 165,000 psi  
 Yield Strength ..... up to 91,000 psi  
 Elongation ..... approx. 20%

ORDER QTY. - 1 PKG

Part No.	Size	Pcs/Lb	Amperage	Wt/ Pkg
21-370	3/32 x 10"	31	50-70	1 LB
21-371	"	"	"	5 LB
21-372	1/8 x 14"	12	70-120	1 LB
21-373	"	"	"	5 LB

Flux color: Blue.

## RUST-BUSTER

FOR CLEAN OR CONTAMINATED MILD STEELS

Our best "general purpose" electrode with a special coating that allows welding over extremely rusty, painted, greasy, oil soaked or scaley base metals. Bridges gaps where poor fit-ups are encountered. Use on trailer bodies, garbage trucks, galvanized iron pipes, tanks, structural steels, I-Beams, girders and floor plates. Use in all positions.

Current ..... AC/DC±  
 Tensile Strength ..... up to 85,000 psi  
 Yield Strength ..... up to 69,000 psi  
 Elongation ..... approx. 25%

ORDER QTY. - 1 PKG

Part No.	Size	Pcs/Lb	Amperage	Wt/Pkg
21-384	1/8 x 14	17	30-140	1 LB
21-385	"	"	"	10 LB

Flux color: Brown.

## UNI-CAST

FOR HIGH STRENGTH WELDS ON CAST IRON HOUSINGS AND SPROCKETS

Alloyed electrode designed for dirty, old, oil soaked and contaminated cast irons. Use on heavy or thin sections. Welds cast iron to steel. Use on sewer pipe, gear and transmission housings, sprockets and machine bases. Use in all positions. NOTE: PREHEATING REQUIRED.

Current ..... AC/DC+  
 Tensile Strength ..... up to 75,000 psi  
 Elongation ..... 23%  
 Hardness ..... HB 210

ORDER QTY. - 1 PKG

Part No.	Size	Pcs/Lb	Amperage	Wt/Pkg
21-386	1/8 x 14	15	70-110	1 LB
21-387	"	"	"	10 LB

Flux color: Black.

## CLEAN-WELD

FOR LOW CARBON STEELS WITH CLEAN, CLOSE FITS

A premium electrode designed for easy operation ... even with small AC welding machines. Can be used on applications requiring short intermittent or spot welds without any restart problems. Sheet metals, ducts, frames, containers, machine bases and piping. Use in all positions.

Current ..... AC/DC±  
 Tensile Strength ..... up to 80,000 psi  
 Yield Strength ..... up to 68,000 psi  
 Elongation ..... approx. 24%

ORDER QTY. - 1 PKG

Part No.	Size	Pcs/Lb	Amperage	Wt/Pkg
21-374	3/32 x 14	26	35-80	1 LB
21-375	"	"	"	10 LB
21-376	1/8 x 14	15	65-125	1 LB
21-377	"	"	"	10 LB

Flux color: Sand.

## ROCK-CRUSHER

HARD-SURFACING ROD FOR IMPACT RESISTANT WELDS ON CONSTRUCTION AND MINING EQUIPMENT

We recommended this rod for all severe abrasion and moderate impact applications. High Rockwell C rating for rock crushing applications, bucket teeth, front end loaders, graders, wear plates, axles, shafts, cutter heads, auger points, mill hammers and plow shears. Use in all positions except vertical down.

Current ..... AC/DC+  
 Hardness ..... Rc 57-61

ORDER QTY. - 1 PKG

Part No.	Size	Pcs/Lb	Amperage	Wt/Pkg
21-390	1/8 x 14	9	80-125	1 LB
21-391	"	"	"	10 LB

Flux color: Gray.

## MACHINE-CAST

FOR SOFT, MACHINABLE CAST IRONS • WILL NOT SIDE-ARC

For maximum machinability. A premium electrode for regular grades of gray cast iron, particularly on thin to medium sections. Welds cast iron to steel. Repair pipe flanges and foundry defects. Special flux coating allows welding in areas where the side of the electrode comes in contact with the metal and side-arc can't be tolerated. Use in all positions.

NOTE: PREHEATING NOT NECESSARY in most cases, except during cold weather.

Current ..... AC/DC+  
 Tensile Strength ..... up to 50,000 psi  
 Hardness ..... HB 150

ORDER QTY. - 1 PKG

Part No.	Size	Pcs/Lb	Amperage	Wt/Pkg
21-388	1/8 x 14	13	65-115	1 LB
21-389	"	"	"	5 LB

Flux color: Rust.



# Maintenance Electrodes & Brazing Rods



## STAINLESS

WELDS 300 SERIES STAINLESS STEELS

Designed for corrosion resistant welds on low carbon molybdenum bearing stainless steels types 302, 304, 308 and 316. Beads are smooth with little spatter. Use on hospital, dairy and distillery equipment, food and processing equipment, chemical vats and mixers, propellers, stainless castings and heat exchangers. Use in all positions.

Current .....	AC/DC+
Tensile Strength .....	up to 100,000 psi
Yield Strength .....	up to 65,000 psi
Elongation .....	approx. 40%
Hardness .....	HB 180

ORDER QTY. - 1 PKG

Part No.	Size	Pcs/Lb	Amperage	Wt/Pkg
21-378	3/32 x 10"	32	40-90	1 LB
21-379	"	"	"	5 LB
21-380	1/8 x 14"	13	75-120	1 LB
21-381	"	"	"	5 LB

Flux color: Off-White.

## ALUMINARC

FOR ELECTRIC ARC OR GAS WELDING ALUMINUM

Yes, even you can weld aluminum and get porosity free welds. Use on both cast or wrought aluminum. Excellent for truck bodies, engine blocks, heads, boat propellers, loading ramps, platforms, ladders, tanks and refrigeration equipment. Use in all positions except vertical down. **PREHEATING RECOMMENDED ON HEAVY SECTIONS.**

Current .....	DC+
Tensile Strength .....	up to 34,000 psi
Elongation .....	approx. 15-25%
Hardness .....	HB 40-55

ORDER QTY. - 1 PKG

Part No.	Size	Pcs/Lb	Amperage	Wt/Pkg
21-382	1/8 x 14	34	80-130	1 LB
21-383	"	"	"	5 LB

Flux color: White.

## LIL' BRAZER

FLUX COATED BRONZE BRAZING ROD FOR STRONG WELDS

Bronze alloy for torch brazing most ferrous and nonferrous metals (not for aluminum). Use on mufflers and exhaust pipes, bicycles, sheet metal and small mechanisms.

Tensile Strength .....	up to 64,000 psi
Working Temperature .....	1600°F
Hardness .....	HB 80-110

ORDER QTY. - 1 PKG

Part No.	Size	Pcs/Lb	Wt/Pkg
21-392	1/8 x 18	14	1 LB
21-393	"	"	10 LB

Flux color: White.

# MIG Welding Wire

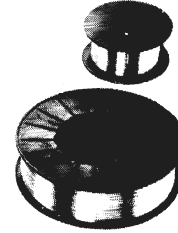

## TYPE E71T-GS FLUX CORE STEEL MIG WELDING WIRE

SELF-SHIELDING. DESIGNED FOR WELDING THIN GAUGE GALVANIZED AND MILD STEELS

All position, low carbon, self-shielding wire for single pass applications. Excellent results on thin gauges of galvanized and mild steels. Travel speed is high and weld edges are smooth. The use of DC straight polarity minimizes the risks of burn through. **DESIGNED FOR GAS-LESS MIG WELDING. TENSILE STRENGTH: 76,000 PSI. USE IN WELL VENTILATED AREAS.**

ORDER QTY. - 1 ROLL

Part No.	Wire Diameter	Spool Size
21-412	.030	2 LB
21-413	"	10 LB
21-414	.035	2 LB
21-415	"	10 LB

*The operator appeal, bead appearance, and spatter is not equal to type ER70S-6 wire below, but the benefits of not having to use gas make this product extremely popular.*

## TYPE ER70S-6 SOLID STEEL MIG WELDING WIRE

USE WHERE A HIGH STRENGTH, FINISHED WELD APPEARANCE IS DESIRABLE. IDEAL FOR SCALED, RUSTY AND OILY PLATES.

All position, low carbon, high manganese, very high silicon wire. Use where a higher alloy is needed. Excellent wetting action, straight bead edges, excellent arc action, and high resistance to rust or mill scale porosity. Allows welding over some dirt and rust. **REQUIRES SHIELDING GAS; RANGE FROM 100% CO<sub>2</sub> TO HIGH ARGON BLENDS. TENSILE STRENGTH WITH CO<sub>2</sub>: 82,000 PSI.**

ORDER QTY. - 1 ROLL

Part No.	Wire Diameter	Spool Size
21-416	.023	2 LB
21-417	"	10 LB
21-418	.030	2 LB
21-419	"	10 LB
21-420	.035	2 LB
21-421	"	10 LB

VISIT US ON THE WEB AT  
[WWW.MPI-ONLINE.COM](http://WWW.MPI-ONLINE.COM)

# Twin Welding Hose Assembly

(Oxygen-Acetylene Hose)



Grade R (Rubber) twin line for gas welding and cutting torches. EPDM tube, multi-spiral reinforcement, EPDM cover. Operating temperature: -40°F to 212°F. Made in U.S.A. Brass swivel fittings crimped at each end with 1" long ferrule. Size: 1/4" ID x 50 ft. Pkg: 1 ROLL. **Part No. 21-299**

# Welding Hose Quick Disconnects

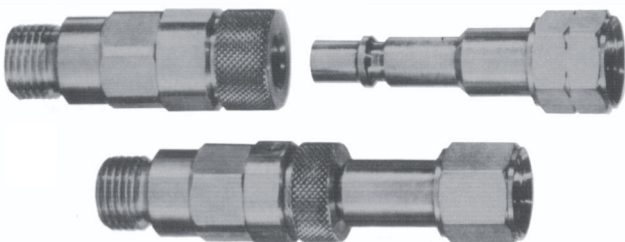

## INSTANT CONNECTIONS SPEED SET-UP & TAKE-DOWN

Fingertip action connects and disconnects equipment. Rugged and lightweight - only 1½ oz. each. Spring-loaded design with locking action for gas-tight, dual seat connection. Designed for welding, cutting, brazing and plasma applications. Durable brass construction. 100% tested. *Color-coded red for fuel gases, green for oxygen. Non-interchangeable Oxygen/Fuel Gas connectores prevent accidental gas mixing. Convenient 'Push-To-Connect' style couplers. Exceeds CGA flow specifications. High flow design delivers up to 1100 SCFH at 125 PSIG. Fits all standard torch handles. B-Size, 9/16-18. UL listed. Made in U.S.A. Pkg Qty: 1 each*

Part No.	Description
21-482	Complete Torch-to-Hose Set (Set contains one each item shown below)
21-478	Oxygen Nipple* Torch-to-Hose
21-479	Oxygen QD Coupler Torch-to-Hose
21-480	Acetylene Nipple* Torch-to-Hose
21-481	Acetylene QD Coupler Torch-to-Hose

*Note: Install at the torch end. \*Nipples supplied with check valves. Also available for Hose-to-Hose and Regulator-to-Hose connections.*

# Flashback Arrestors



**DELIVERS EXTRA PROTECTION!**

Extra protection against flashbacks that can ignite hoses or gases. Flashback arrestors help prevent flashback flames caused by reverse gas flow. Replaces low quality or defective reverse flow check valves. Integral reverse flow check valve guards against reverse flow of flammable gas mixtures. Flame arrestor quenches flashback flames. Durable brass construction. 100% tested. Color-coded red for fuel gases, green for oxygen. *Maximum cutting capacity is 10". Manual resetting not required. Fits all standard torches and regulators. B-Size, 9/16-18. Made in U.S.A.*

*NOTE: OSHA regulations require fuel gas supply systems to be equipped with approved devices to prevent backflow of flammable gas mixtures when properly maintained.*

## TORCH MOUNTED SET

Installed at the torch end to provide added protection of more components - hoses, regulator and cylinder. Fits all standard B-size (9/16-18") torch inlets. UL listed. Set of 2, carded. Pkg: 1 SET. **Part No. 21-355**

## REGULATOR MOUNTED SET

Subject to less contamination and abuse. Easily mounts to any B-size (9/16-18) outlet nipple on regulator. UL listed. Set of 2, carded. Pkg: 1 SET. **Part No. 21-356**

# Swivel Nut Welding Hose Connectors



Part No.	1 Hose I.D.	2 Thread Size	Pkg Qty
<b>RIGHT-HAND THREAD (OXYGEN)</b>			
13-416	3/16"	9/16-18	6
13-417	1/4"	9/16-18	6
13-418	5/16"	9/16-18	6
13-419	3/8"	9/16-18	6
<b>LEFT-HAND THREAD (ACETYLENE)</b>			
13-420	3/16"	9/16-18	6
13-421	1/4"	9/16-18	6
13-422	5/16"	9/16-18	6
13-423	3/8"	9/16-18	6

# Welding Unions



Use to couple welding hoses for extra length.

Part No.	Size/Thread	Pkg Qty
13-424	9/16-18 Right-Hand (Oxygen)	6
13-425	9/16-18 Left-Hand (Acetylene)	6



# Torch Cutting Tips



**AIRCO/CONCOA STYLE**



**VICTOR STYLE**



**SMITH STYLE**



**HARRIS STYLE**



**PUROX/LINDE/L-TEC STYLE**



**OXWELD/LINDE/L-TEC STYLE**

Manufacturer	Mfr's Part No.	Size	Our Part No.
Airco/Concoa	144-00	00	943
Airco/Concoa	144-0	0	978
Airco/Concoa	144-1	1	979
Airco/Concoa	144-2	2	944
Airco/Concoa	144-3	3	945
Airco/Concoa	164-00	00	946
Airco/Concoa	164-0	0	980
Airco/Concoa	164-1	1	981
Airco/Concoa	164-2	2	947
Airco/Concoa	164-3	3	948
Victor	1-101-00	00	950
Victor	1-101-0	0	982
Victor	1-101-1	1	983
Victor	1-101-2	2	951
Victor	3-101-00	00	952
Victor	3-101-0	0	984
Victor	3-101-1	1	985
Victor	3-101-2	2	953
Smith	SC12-00	00	954
Smith	SC12-0	0	986
Smith	SC12-1	1	987
Smith	SC12-2	2	955
Smith	SC12-3	3	956
Smith	SC12-4	4	957
Smith	SC12-5	5	958
Smith	SC12-6	6	959

Manufacturer	Mfr's Part No.	Size	Our Part No.
Harris	6290-00	00	960
Harris	6290-0	0	988
Harris	6290-1	1	989
Harris	6290-2	2	961
Harris	6290-3	3	962
Harris	6290-4	4	963
Purox/Linde	4202-3	3	991
Purox/Linde	4202-4	4	964
Purox/Linde	4202-5	5	965
Oxweld/Linde	1502-2	2	966
Oxweld/Linde	1502-3	3	992
Oxweld/Linde	1502-4	4	967

*Cutting tip sizes and brands not shown also available on special request. We can also supply cutting attachments, torch handles, welding heads, heating nozzles, cylinder regulators and complete cutting outfits.*

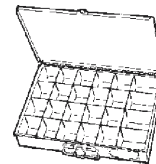

**We can make assortments to your specifications!**





# Propane Torches/Fuel Cylinders

## BERNZOMATIC® Trigger Start Torch\*



Solders, sweats, heats and melts! Trigger start activates Piezo ceramic ignitor for thousands of easy torch lights....No spark lighter or matches needed! Solid brass, regulated fuel valve provides efficient operation at any angel. Fuel nob adjusts and extinguishes flame. Superior performance in cold weather. Comfortable, easy-to-hold grip made of high impact ABS material. Uses standard 14.1 oz. propane cylinders\*. Not recommended for MAPP™ gas. Made in the U.S.A.

**Part No. 31-016** \*Note: fuel cylinder sold separately.

## Shrink-Jet™ Flameless Butane Heat Tool

A flameless, self-igniting heat tool fueled by butane lighter! Great for outdoor use, because its windproof. Will not burn parts or wire insulation. Adjustable heat range and safety trigger lock. Even works with ElectraLink™ solder terminals!  
1 tubing deflector and 1 refillable fuel cell included!



**SHRINK-JET Heat Tool**  
**Part No. 10-724**

**Fuel Cell only (refillable)**  
**Part No. 10-730**

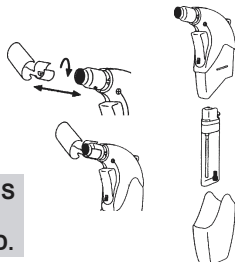

**THIS ITEM SHIPPED VIA UPS  
GROUND ONLY. AIR FREIGHT  
ORDERS WILL NOT BE ACCEPTED.**

## Pencil Flame Torch



Traditional medium duty propane torch for general purpose work. Tip produces a concentrated flame for detail work. It can solder up to 3/4 OD copper tubing and silver braze 1/4" diameter copper tubing. Generates 4900 BTUs per hour. Made in the U.S.A.

**Part No. 31-018**

## Disposable Fuel Cylinders

Fits standard burners, propane torches, lanterns, stoves, etc. Disposable steel cylinder. Grade HD-5 propane per NGPA standards.



**NOTE: THIS ITEM CANNOT BE  
SHIPPED VIA U.P.S.**

Part Number	Size	Pkg Qty
30-242	14.1 oz. Cylinder	12

Why are they called buildings,  
when they're already finished?  
Shouldn't they be called "builts"?



# Solder & Flux

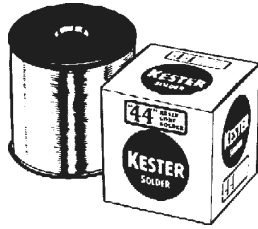

## Kester 40/60 Resin Core Solder

For most electrical applications. 40% Tin, 60% Lead. Melting point: 460°F. Diameter: .093" (3/32"). 1 lb. spools. **Part No. 21-303**

## Kester 40/60 Acid Core Solder

For radiators, plumbing, and sheet metal repairs. 40% Tin, 60% Lead. Melting point: 461°F. Diameter: .093" (3/32"). 1 lb. spools. **Part No. 21-304**

## Kester 50/50 Solid Wire Solder

Used extensively in plumbing work and with crafts. 50% Tin, 50% Lead. Melting point: 421°F. Diameter: .125" (1/8"). 1 lb. spools. **Part No. 21-305**

## Kester "Economy Series" Solder

A commercial grade designed for the occasional solder user. 1/8" diameter, 1 lb. spools.

- 21-306 ..... Resin Core Solder
- 21-307 ..... Acid Core Solder
- 21-308 ..... Solid Wire Solder



## Kestor "Kwik-Draw" 60/40 Resin Core Solder

A strong, low-temperature solder. Use for all electrical applications. 60% Tin, 40% Lead. Melting point: 360°F. Diameter: .050" (3/64"). Size: 1.3 oz. Pkg: 6 tubes. **Part No. 21-309**

## Liquid Soldering Flux

(Tinnings Fluid) Use to clean solder joints. 4 oz. bottle. **Part No. 21-324**



## Acid Soldering Paste Flux

Use with solid wire solder for lead-free plumbing (non-electrical) repairs. **Part No. 21-325**



# Metal Markers



## Valve-Action Paint Marker

Valve-action releases paint as needed. Felt tip makes long-lasting, bold marks on all surfaces -- metal, glass, wood, rubber, paper, cardboard, styrofoam, and fiberglass. Compact size fits in shirt pocket. Durable metal barrel. Lead-free, fade resistant paint. Complete assortment of colors in stock. *Temperature range: -50°F to 150°F. Dries in 3 minutes. Markal brand.*

Part No.	Color	Pkg
10-727	White	12
10-728	Yellow	12
10-737	Red	12
10-738	Black	12
10-739	Orange	12
10-740	Dark Blue	12
10-741	Green	12
10-743	Aluminum	12
10-744	Light Blue	12

## Ball Tip Paint Marker

Durable 1/8" metal ball tip lasts and lasts. Marks both smooth and rough surfaces. Lead-free, fade resistant paint. *Temperature range: -50°F to 150°F. Dries in 5 minutes. Markal brand.*



Part No.	Color	Size	Pkg
10-729	Yellow	1 oz. bottle	12

## Flat Soapstone

Marks steels and other alloys where other markers fail. Size: 1/2"W X 3/16"T X 5"L **Part No. 21-483 / 1 Pkg. (12 pcs)**  
**Part No. 21-483C / 1 Case (144 pcs)**



## Soapstone Holders

Use for marking and outlining weld areas on steel. Indexable/retractable holder comes with flat soapstone. Pkg: 12 each. **Part No. 21-484**

# Welding Accessories

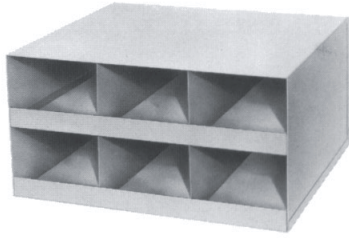

## Steel Welding Rod Cabinet

Compartment are 4"H x 5¼"W. Cabinet size is 18½"D x 8"H x 16"W. **Part No. 98-WRC**



## 3-Flint Spark Lighter

3 large flints provide up to 6,000 ignitions. Rotatable file allows for continuous fresh surface. Sturdy hand grip frame. **Part No. 21-326**

EXTRA FLINTS FOR ABOVE  
Part No. 21-326R (Pkg. 5 ea)



## STANDARD SPARK LIGHTER

Large hood traps more gas. Provides up to 1,500 ignitions. **Part No. 21-327**

EXTRA FLINTS FOR ABOVE  
Part No. 21-327R (Pkg. 5 ea)



## T-Handle Tank Wrench

Fits fuel and oxygen valves with a 9/32" stem. **Part No. 21-485**

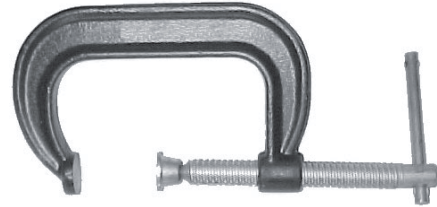

## Drop Forged "C" Clamps

Copper coated stem for spatter resistance.

Part No.	Capacity		Throat Depth
	Max.	Min.	
10-669	4"	0"	2-3/4
10-670	6"	0"	3-5/8
10-671	8"	0"	4-1/2
10-672	10"	0"	5-3/8
10-673	12"	0"	5-3/4



## Tip Drill Kit

Properly cleans cutting and welding tips. Pencil size aluminum holder stores drill assortment in barrel. Contains 12 assorted wire sized drills. **Part No. 21-329**

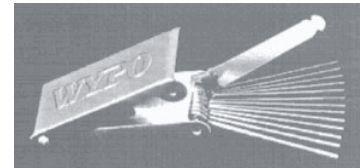

## Torch Tip Cleaner

13 assorted files replace drill sizes #49 thru #77. In fold-up holder. **Part No. 21-330**

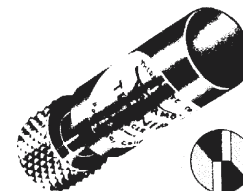

*Tool steel cutter*

## Torch Tip Refacing Tool

Restores pitted and slag-damaged torch tips to new tip performance without removing from the torch. Just place the nylon tapered sleeve over the tip and give the cutter a few turns. **Part No. 21-357**



# Welding Accessories

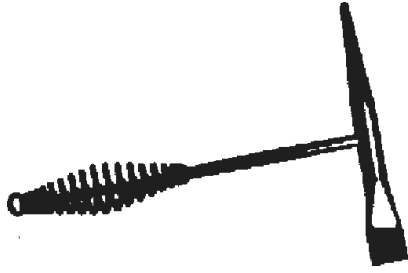

## Weld Chipping Hammers

A quality weld cleaning tool features Flex-O-Steel handle and safety pinned head. Cone and chisel head style.  
**Part No. 21-328**

## Welding Cable



Jacket is thermoset neoprene with Class K #30awg soft drawn copper stranding. Stays flexible in cold temperatures and easy to route in tight places. Delivers up to 600 volts of power. Resistant to oil, flame, heat, weather, UV rays and abrasion. Temperature range: -40°F to 194°F. Color is black.

- 1/0 commonly used with 200-250 Amp Holders & Ground Clamps
- 2/0 commonly used with 300 Amp Holders & Ground Clamps
- 3/0 commonly used with 400-500 Amp Holders & Ground Clamps

## Wire Scratch Brushes

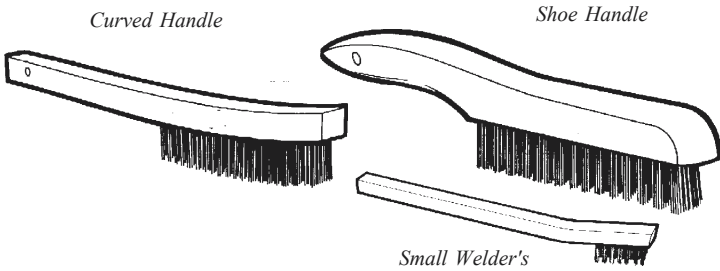

Choose from carbon steel or stainless steel wire.  
 Solid wood handles.

PART NO.	DESCRIPTION	ROWS OF WIRE	PKG. QTY.
<b>SHOE HANDLE BRUSHES</b>			
6-133	Carbon Steel	4	12
6-134	Carbon Steel w/Scraper	4	12
6-135	Stainless Steel	4	12
<b>CURVED HANDLE BRUSHES</b>			
6-130	Carbon Steel	3	12
6-131	Carbon Steel w/Scraper	3	12
6-132	Stainless Steel	3	12
<b>SMALL WELDER'S BRUSHES*</b>			
6-128	Stainless Steel	4	12

*\*Also available in brass.*

Part No.	Gauge	Conductor Diameter*	Pkg Qty
26-473	4	.260"	100'
26-474	2	.325"	100'
26-475	1	.365"	100'
26-476	1/0	.430"	100'
26-477	2/0	.470"	100'
26-478	3/0	.520"	25'
26-479	4/0	.600"	25'

*\*Actual conductor diameters vary depending on specific stranding of wire. CABLE SIZING CHART ON PAGE 187.*

## 300 Amp Electrode Holder

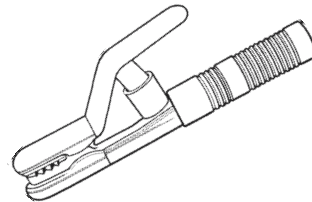

Electrode capacity is 1/4". Cable capacity 4 ga.- 2/0.  
**Part No. 21-331**

## 300 Amp Grounding Clamp

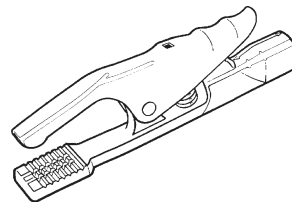

Jaw opens to 1-5/8 inches. Cable capacity 1/0 and 2/0.  
**Part No. 21-332**

# Welding Accessories

## JACKSON Shadow™ Welding Helmets

Lightweight - only 13 ounces. Streamlined shell for work in tight places. Space-age copolymer material withstands heavy impact, extreme heat, and provides better insulation for cooler wear. Balanced for easy nod down. Extended throat and neck protection against sparks,



slag and fumes. Available in four colors. Adjust-O-Lok headgear and shade 10 filter plate installed and ready to go! *Not recommended for overhead welding.* Bifocal wearers will appreciate the large vertically placed 4½" x 5¼" window model.

Part No.	Window Style	Window Size	Color
21-333	Fixed-Front	4½" x 5¼"	Black
21-334	Fixed-Front	4½" x 5¼"	Blue
21-335	Fixed-Front	4½" x 5¼"	Red
21-336	Fixed-Front	4½" x 5¼"	Silver
21-337*	Lift-Front	2" x 4¼"	Black

*\*Not pictured. Lift-Front Shadow Helmet has a horizontally placed window.*

## JACKSON Lift-Front Welding Goggles

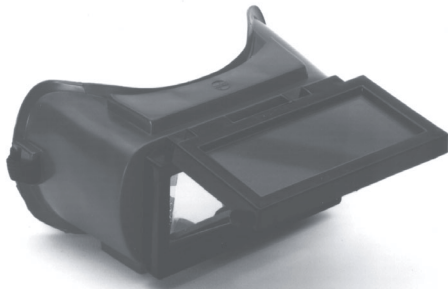

Recommended for gas welding and cutting only. Flexible plastic frame hugs facial contour for comfortable fit. Ventilated. Durable elastic head band. Size: 2" x 4¼" lift front with shade 5 filter. Made in U.S.A. **Part No. 21-339**

*Warning: These goggles provide limited face and eye protection. Goggles and lenses are not unbreakable. Do not use for arc welding.*

## JACKSON Journeyman™ Welding Helmets with EQC™ Filter



Auto-Darkening technology is here! Each Journeyman™ features: Lightweight Shadow™ shells, EQC FILTERS (electronic quick-change) with a switch time of 1/25000 of a second, viewing area of 1-1/15" x 3-3/4" , "on" switch with energy-saving "auto-off" feature (shuts down when helmet is not in use), IR/UV protection at all times, patented Adjustolok® headgear, one year warranty. Color is black. Made in U.S.A.

Part No.	Description
29-470	Helmet with preset filter (shade 10)
29-472	Helmet with variable filter (8.5 to 12.5)

*Uses two AAA alkaline batteries (included).*

## JACKSON Adjustolok™ Welding Helmet Headgear

Replaces headgear found on all Jackson brand welding helmets. Soft vinyl forehead cushion. Adjustolok features size adjustment without helmet removal. Made of molded nylon.

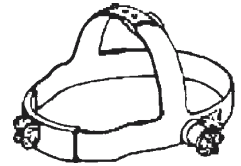

Made in U.S.A. **Part No. 21-338**

## SAFETY GOGGLES

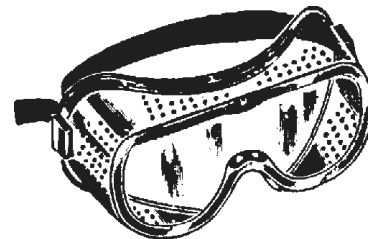

Conforms to OSHA. Molds to contour of face, protecting eyes from dust, spray and flying particles while sanding, cutting wood, grinding and painting. Impact resistant lens. May be worn over eyeglasses. **Part No. 10-486**



# Welding Filters



**Green Filters:** Wide choice of shades. Hardened glass.

**Gold Coated Filters:** reflection coating for much cooler welding, better UV protection, and less weight. Made from lightweight polycarbonate.

**Clear Glass Cover;** an outer cover plate to help prevent pitting of filters - prevents distortion. Hardened glass.

**Clear Liner;** an inner safety cover plate that helps protect eyes from impact of shattered glass lenses. Made from cast plastic. May also be used as an outer cover plate for less weight.

All Pkg: 6 each

Part No.	Shade	Type	Pkg
<b>2" X 4 1/4" FILTERS</b>			
21-342	5	Green Glass	6
21-343	10	Green Glass	6
21-344	12	Green Glass	6
21-345	5	Gold Polycarbonate	6
21-346	10	Gold Polycarbonate	6
21-347	12	Gold Polycarbonate	6
<b>2" X 4 1/4" SAFETY PLATES</b>			
21-348	Clear	Glass Cover Plate	6
21-349	Clear	Plastic Inner Liner	6
<b>4 1/2" X 5 1/4" FILTERS</b>			
21-358	10	Green Glass	6
21-359	12	Green Glass	6
21-360	10	Gold Polycarbonate	6
21-361	12	Gold Polycarbonate	6
<b>4 1/2" X 5 1/4" SAFETY PLATES</b>			
21-362	Clear	Glass Cover Plate	6
21-363	Clear	Plastic Inner Liner	6

## Selection of Shade Number for Welding Filters

OPERATION	SHADE NUMBER
Shielded Metal-Arc Welding (Arc), up to 5/32" electrodes	10
Shielded Metal-Arc Welding (Arc), 3/16" to 1/4" electrodes	12
Shielded Metal-Arc Welding (Arc), over 1/4" electrodes	14
Torch Brazing	3 or 4
Torch Soldering	2
Oxygen Cutting, light cutting, up to 1" material	3 or 4
Oxygen Cutting, medium cutting, 1" to 6" material	4 or 5
Oxygen Cutting, heavy cutting, over 6" material	5 or 6
Gas Welding (Light) up to 1/8" material	4 or 5
Gas Welding (Medium) 1/8 to 1/2" material	5 or 6
Gas Welding (Heavy) over 1/2" material	6 to 8
Oxyacetylene Flame Spraying	5
Gas Metal-Arc Welding (MIG)	12
Gas Tungsten-Arc Welding (TIG)	12
Plasma Flame Spraying	12
Atomic Hydrogen Welding	12
Carbon Arc Welding and Cutting	14

# Lens Cleaning Stations



Disposable, chip board dispenser can be mounted anywhere to encourage use of safety goggles and spectacles. Includes anti-static, anti-fog cleaning solution and lens cleaning tissues.

Part No.	Description	Cleaning Solution
10-731	Small station w/ 500 tissues	8 oz.
10-732	Large station w/1600 tissues	16 oz.

# Elastic Sweat Bands



Thick, open cell cellulose sponge with elastic band. Can be positioned anywhere. Length: 8 1/2"

Part No.	Description	Pkg. Qty.
21-364	Elastic Sweat Bands	10 each
21-364C	"Case of 100"	1 Case

# Disposable Foam Ear Plugs

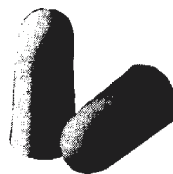

Tapered for easy insertion. Hygienically packaged in biodegradable paper pouches. Brightly colored for easy compliance checks. Rated NRR 31. Made in U.S.A.

Part No.	Size	Unit
29-400	5 pair bag	1 PKG
29-401	200 pair dispenser box	1 PKG

# Safety Products

## TRITON™ Safety Spectacles Replaceable Lens Option



Triton™ safety spectacles have a sporty "aviator" look that most workers want to wear. Features lightweight, one-piece frame, universal bridge, temple length adjustment, and the REPLACEABLE hard-coated polycarbonate lens option. Integral side shields comply with ANSI Z87.1-1989. Made in U.S.A.

Part No.	Frame/Lens	Pkg
<b>SPECTACLES</b>		
10-691	Aqua/Clear	10
10-692	Red/Clear	10
10-693	Aqua/Smoke†	10
<b>REPLACEMENT LENSES</b>		
10-697	Clear	10
10-698	Smoke†	10

†Tinted lenses are for protection against sun and glare only, not for welding.

## SABRE™ Safety Spectacles



Clear, scratch resistant polycarbonate lenses with advanced UV protection. Lightweight contoured frame with partial brow bar and adjustable temples. Large 58mm eye size and universal bridge. Color is tan with tinted side shields. Meets ANSI Z87.1-1989. Made in U.S.A. Pkg: 10 each. **Part No. 21-340**

## IMAGE SERIES Attitudes™ Safety Eyewear



Attitudes™ have a sporty "racer" look that most workers want to wear. Features black plastic frame and temple, wrap-around temples, ultra lightweight design and universal nose bridge. Integral side shields comply with ANSI Z87.1-1989. Imported.

Part No.	Lens	Pkg
29-450	Clear	10
29-452†	Clear, UV coated	10
29-454†	Smoke	10
29-456†	Silver mirror	10

**Metal Attitudes™** have a sleek, contemporary look featuring classic metal frame, lightweight black plastic temples, full integral side-shields, and padded nose bridge. Removable side-shields comply with ANSI Z87.1-1989. Imported.

Part No.	Lens	Pkg
29-458	Clear	10
29-460†	Blue smoke	10
29-462†	Silver mirror	10
29-464†	Blue mirror	10

†29-452 UV resistant, anti-scratch, anti-fog, anti-static coating. †Tinted lenses are not UV resistant.

## Clear Visitors Spectacles

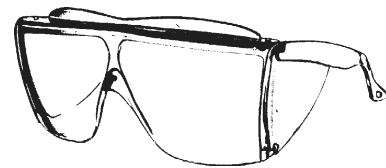

Economical spectacles with side shields fits over prescription eyeglasses. Not intended for unlimited eye protection. Handy dispenser box. Color is clear. Pkg: 12 **Part No. 21-341**



# Safety Products

## Face Shield Visors

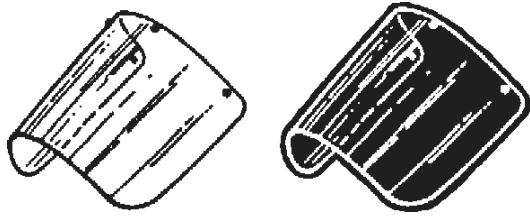

Universal hole pattern to fits most headgear brands. Used for face and eye protection against light impact such as small particles and dusts, splash from non-hazardous liquids.

Part No.	Shade	Application
21-286	Clear	General protection
21-287	Green*	Sun & glare protection
21-288	Shade 5	Gas welding/cutting

**WARNING:** Visors do not provide unlimited face and eye protection. Not unbreakable; will not protect you against severe impact, corrosive liquids, ultraviolet (arc) or infrared (heat) radiation, or molten metal. Impact resistant eye protection (safety spectacles) must be worn at all times.

\*Use green tinted for protection against glare only, not intended for welding or torch cutting.

## Ratcheting Face Shield Headgear

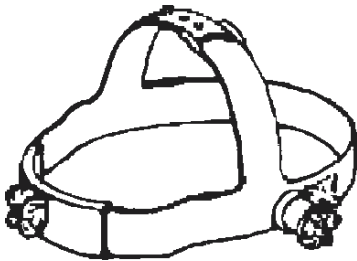

Flexible and comfortable. Size can be changed while being worn, simply by turning the ratcheting adjustment knob. Adjustable "up-and-down" visor movement. Soft padded head band. *Visors sold separately (above).*

**Part No. 21-289**

Remember the safety question!

**“What’s the worst that can happen if I do this?”**

## Safety Hard Hats



Protect workers from falling objects and hazards that can inflict painful bumps and lacerations. Sides are *slotted* for use with face shields, welding helmets and hearing protectors equipped with mounting blades. Constructed of durable, lightweight dielectric plastic with impact absorbing design. A soft, foam forehead cushion included. Ratcheting suspension. Complies with ANSI Z89.1 standards. Made in U.S.A.

Part No.	Color	Pkg. Qty.
21-296	White	1
21-297	Orange	1
21-298	Yellow	1

*Also available: green, red, blue, gray, black & safety orange.*

## Bump Caps



Bump caps protect workers from hazards that can inflict painful bumps and lacerations. Do not use to protect against falling objects. Adjustable suspension.

*Not ANSI approved.*

Part No.	Color	Pkg. Qty.
21-293	Orange	1
21-294	White	1
21-295	Yellow	1

## Hearing Protectors



Industrial quality protection from moderate noise levels irritating or harmful to hearing. Designed for lighter tension and greater wearer acceptance. Noise reduction level: 21 decibels. Meets OSHA and ANSI standards. Pkg: 1 each. **Part no. 29-414**



# Safety Products

## Dual Cartridge Half-Mask Respirator



For protection against in paint and pesticide sprays and vapors, chlorine and muriatic acid, lead and asbestos dust/fumes, fiberglass insulation, solvents/glues/thinners, lacquer and enamels, sanding dusts and particles. Designed for the do-it-yourselfer and industrial applications. Soft, pliable rubber facepiece for comfortable fit. Easy breath-ability. Low profile. *Complies with OSHA regulations for industrial respiratory protection. NIOSH TC-B4A-0991 approval. A/O Safety brand.*

Part No.	Description	A/O Safety Item No.
21-290	Respirator with cartridges	95050
21-291	Repl. cartridges, 1 pair	95061

## MOLDEX 2300 Particulate Respirator WITH EXHALE VALVE

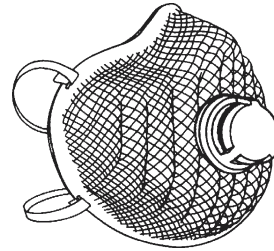

**NO METAL BAND!**

Use against particulate aerosols free of oil\*. Exhale valve lets workers breath easier and stay cooler. Durable molded poly-mesh shell resists collapsing in heat and humidity. Molded nose bridge maintains seal for a comfortable fit. Two straps in back for comfortable, secure fit. *Meets OSHA guidelines for use up to 10 x PEL (permissible exposure level), NIOSH 42CFR84 N95, TC-21C-350 approvals.*

### Part No. 23-319

Pkg: 10 each *Sold in full packages only.*

**WARNING:** *DO NOT USE AGAINST fumes, gases, vapors, asbestos, silica (sand blasting), graindust, spray paints or other harmful substances. This mask will not protect your lungs.*

## 3M 8210 Dust Respirators

Dependable protection against dust and mists with a PEL (permissible exposure level) not less than .05 mg/m<sup>3</sup>. Use for dusts from insulation,

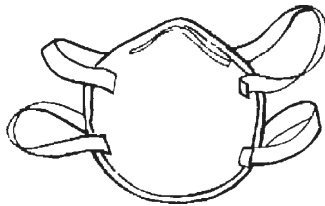

processing minerals, coal, lead, iron ore, cotton, flour and certain other substances. Use to protect against mists from sprays that do not produce harmful vapors (such as latex paints). Use when sanding cured paints, body fillers, fiberglass and woods. Two straps in back for comfortable, secure fit. *NIOSH 42CFR84 N95 approval.*

### Part No. 21-365

Pkg: 20 each *Sold in full packages only.*

**WARNING:** *Not for use against fumes, gases, vapors, asbestos, silica, grain dust, spray paints or other harmful substances. This mask will not protect your lungs.*

## 3M 8500 Comfort Masks

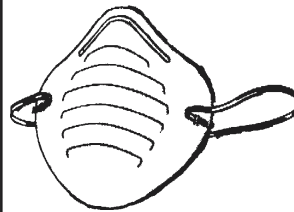

Worn for comfort only. Designed for use against non-toxic/nuisance dusts. Provides no respiratory protection. Offers relief from the irritating effects of common nuisance dusts such as pollen, alfalfa and salt. Single

strap, contour fit, and soft metal nosepiece that conforms snugly around the nose. Easy breathing/speaking. Low profile design may be worn with safety goggles or glasses.

### Part No. 21-366

Pkg: 50 each *Sold in full packages only.*

**WARNING:** *Not for use against asbestos, silica, graindust, spray paints or other harmful substances. This mask will not protect your lungs.*



# Safety Products

## WorkSAFE™ Hazardous Location Flashlights

DIVISION 1 CERTIFIED\*

3-WAY SWITCH

WATERPROOF DESIGN

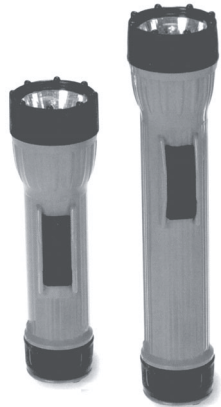

Designed specifically for use in **Division 1 hazardous locations**.\* Each flashlight is individually tested and certified. The waterproof design makes them ideal for wet conditions. Features waterproof 3-way switch with on and off position, and a middle position with a button which can be pressed to provide intermittent flashing. UL listed class I groups C, D, class II group G, and class III. MSHA approved, CSA certified. Meets ASTM type II. Made in U.S.A. Color is orange/black.

- 17-094 2 D-cell WorkSAFE™ Flashlight Pkg: 12 ea
- 17-095 3 D-cell WorkSAFE™ Flashlight Pkg: 12 ea

*\*Division 1 Hazardous Locations: where ignitable concentrations of flammable gases, vapors or liquids can exist all of the time or some of the time under normal operating conditions.*

## Did you know?

The electric light bulb got its present shape because Thomas Edison accidentally dropped a screwdriver on an early light, knocking it out of its original shape and causing it to burn more brightly with increased power.



## Kidde® Fire Extinguishers

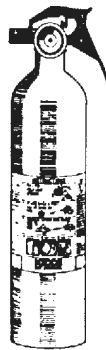

1A:10B:C KIDDE 110

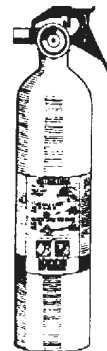

10B:C KIDDE 10



5B:C KIDDE 5

Dry chemical types ABC and BC. For protection against all common classes of fires, you must choose type ABC extinguisher. Easy to read pressure gauges allow instant, accurate pressure check. Aluminum cylinders. U.L. listed and DOT approved. Rechargeable by manufacturer.

**NOTE: THIS ITEM CANNOT BE SHIPPED VIA U.P.S.**



### U.L. Fire Classifications.

- A.** Wood, paper, cloth, rubber, and most plastics. Includes drapes, bedding, upholstery and trash.
- B.** Flammable liquids; gas, kerosene, oil, and grease.
- C.** Electrical appliances and equipment. Home wiring, televisions and electronics.

Part No.	U.L. Rating	Size	U.L Fire Classification		
			A.	B.	C.
16-0091	5B:C	2#	-	X	X
<i>For car or boat.</i>					
16-0092	10B:C	2-3/4#	-	X	X
<i>For car or boat.</i>					
16-0093	1A10B:C	2-1/2#	X	X	X
<i>Recommend 1 for every 600 square feet of living space and sleeping quarters.</i>					
16-0094	3A40B:C	6#	X	X	X
<i>Recommend for kitchen and garage area.</i>					
16-0099	4A60B:C	10#	X	X	X
<i>Heavy duty protection for home or small business.</i>					

# Safety Products

## Deluxe First Aid Kit



Large metal container with rubber gasket for a water-proof, all weather seal. Complies with OSHA requirements. Includes; cold pack, cotton balls, stretch bandage, adhesive tape, sterile pads, sterile eye pads, adhesive strips, Iodine, sting relief medication, antiseptic wipes, triple antibiotic, ointments, eye dressing, tweezers, scissors, first aid guide, buffered aspirin, triangular bandage and burn ointment. Hi-Vis Yellow with black print. **Part No. 17-180**

**DELUXE REFILL PACK.....PART NO. 17-180R**

## Back Support Belts

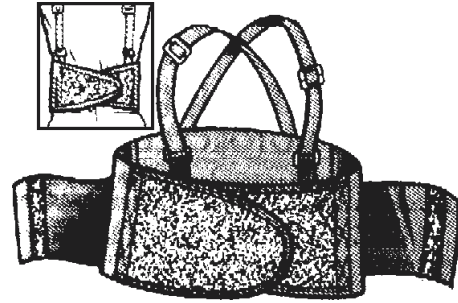

Promotes proper lifting techniques. Can be worn comfortably over long periods of time. Reduces repetitive back strain. Smooth glide adjustable clips on 1" wide fixed suspenders. Easy adjust elastic outer panels with Velcro® closures for added lower back support. Black in color. Made in U.S.A.

Part No.	Size	Fits Waists
23-408	Small	28"-30"
23-409	Medium	32"-38"
23-410	Large	38"-47"

*Other sizes available upon special request.*

## Industrial First Aid Kit



Designed for Industrial-Construction usage. Complete, balanced assortment of items. Weather resistant plastic case. Contents meet ANSI standard Z308.1-1998. For industrial vehicles, farm machinery, trucks and vans. Includes; stretch bandage, adhesive tape, sterile pads, sterile eye pads, adhesive strips, large wound pads, Iodine prep pads, sting relief pads, alcohol pads, sterile eye wash, forceps, scissors, first aid handbook, triangular bandage cold pack, CPR barrier and burn ointment. **Part No. 17-182**

NOTE: REFILLS ARE NOT AVAILABLE FOR THIS KIT.

## Winter Liners

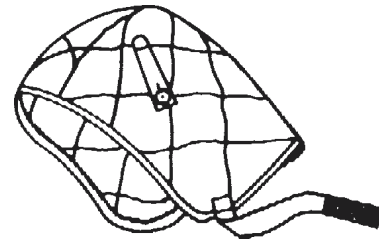

Universal size with extra long nape to protect the back of your neck. Outer shell is tightly woven wind resistant twill. Inner lining is flame resistant flannel like material which very warm and comfortable. Velcro closure on chin strap. Completely dielectric. **Part No. 21-368**

Why are there five syllables in the word "monosyllabic"?



# Disposable Protective Coveralls



REPELLS  
NONHAZARDOUS  
LIQUIDS

## SPUN-BONDED POLYPROPYLENE COVERALLS

ECONOMICAL AND TOUGH 1½ OZ. SPUN-BONDED POLYPROPYLENE. This extra heavy fabric is not only durable, it's washable too! Protects clothing from dust, dirt, oil, grease and paint. Great for common dirty chores, heavy equipment repairs, sand blasting operations and roadside emergencies. *Fabric weight: 1½ oz/sq. yd. Zippered front. Color is white (also available in blue as special order). Not Tyvek® brand. Provides limited splash protection.*

*Not recommended for continuous liquid exposure. Not for use in hazardous applications. Keep away from extreme heat. Made in U.S.A.*

Part No.	Men's Size	Height	Weight	Pkg
29-484	L 42-44	5'5"-5'9"	140-190 lbs.	25 ea
29-486	XL 46-48	5'8"-6'1"	160-210 lbs.	25 ea
29-488	XXL 50-52	5'10"-6'4"	190-250 lbs.	25 ea
29-490	XXXXL 58-60	6'-6'7"	240-300 lbs.	25 ea



REPELLS  
NONHAZARDOUS  
LIQUIDS

ELASTIC HOOD, WRIST  
& ANKLE PROTECTION

## Tyvek® SPUN-BONDED OLEFIN HOODED COVERALLS

SPUN-BONDED OLEFIN™ FABRIC PROVIDES AN EXCELLENT BARRIER AGAINST DRY PARTICULATES AND NONHAZARDOUS LIQUIDS. Soft, spun-bonded olefin nonwoven fabric is pressure bonded to protect clothing from water, dust, dirt, oil, grease, paint and other nonhazardous liquids. Great for power washing, plumbing, painting, dirty chores, equipment repairs and roadside emergencies. *Fabric weight: 1.19 oz/sq. yd. Zippered front. Elastic around hood, wrists and ankles helps keep you dry. Color is white (also available in blue as special order). Provides limited splash protection. Not recommended for continuous liquid exposure. Not for use with hazardous liquids. Keep away from extreme heat. Made in U.S.A.*

Part No.	Men's Size	Height	Weight	Pkg
29-492	L 42-44	5'5"-5'9"	140-190 lbs.	25 ea
29-494	XL 46-48	5'8"-6'1"	160-210 lbs.	25 ea
29-496	XXL 50-52	5'10"-6'4"	190-250 lbs.	25 ea

*Sizes not listed available in case quantities only.*

## ALSO AVAILABLE

*These styles also available...*

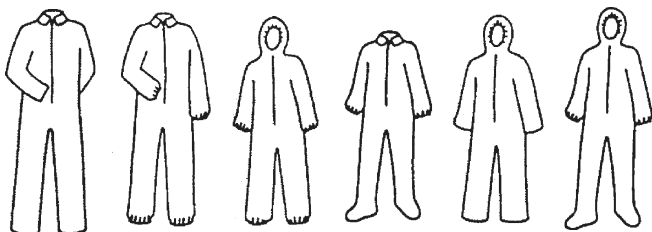

Type 1    Type 2    Type 3    Type 4    Type 5    Type 6

*Also available: Lab coats, frocks, poultry smocks, exam gowns, shirts, pants, bib aprons, sleeve protectors, bouffant caps, shoe covers, boot covers and hoods.*

*These materials also available...*

**Impede 3-Ply:** Rugged polypropylene for wear and abrasion resistance.

**Fire Retardant:** Special fabric designed for high heat areas.

**Polyethylene Coated Tyvek®:** Recommended for continuous exposure to liquids. Yellow coated fabric is resistant to water, mild acids, soap bases and many liquid chemicals.

**Saranex Coated Tyvek®:** Premium fabric designed for protection against harsh chemical splashes, corrosives and acids.

# Work Gloves

## Cotton Grip Style Gloves



**NEW ITEM!**

These gloves ensure a firm hold on slippery objects. Medium weight white cotton string, knit wrists. Blue vinyl dots. Men's size. Made in U.S.A.

<b>Part No.</b>	<b>Pkg</b>
21-275 .....	12 pr

## Jersey Gloves



### Unlined

100% cotton jerseys are excellent for maintenance and clean-up. Knit wrists. Clute pattern. Men's size. Color is brown. Import.

<b>Part No.</b>	<b>Pkg</b>
21-264 .....	12 pr

### Red lined

Fleece lining provides an added degree of comfort and warmth. Driver's style with slip-on cuffs. 100% cotton. Gunn pattern. Men's size. Import.

<b>Part No.</b>	<b>Pkg</b>
21-263 .....	12 pr

## 100% Cotton String Gloves

*(Glove Liners)*



**NEW ITEM!**

These inexpensive knit gloves are comfortable and easy to wear throughout a long work-day. Provides good air circulation, reduces moisture build-up. Medium weight white cotton string, knit wrists. Men's size. Made in U.S.A.

<b>Part No.</b>	<b>Pkg</b>
21-277 .....	12 pr

## Cotton Hot-Mill Gloves



Protects hands from moderate heat. Good abrasion resistance. Men's size, quilted palm, thumb and index finger, band top, knuckle strap. Color is beige. Imported.

<b>Part No.</b>	<b>Pkg</b>
21-262 .....	12 pr

## Kevlar® Knit Gloves



**NEW ITEM!**

These stretch knit, seamless gloves are made of cut and heat-resistant Kevlar fibers that withstand higher temperatures and quickly cool down after removal from hot surfaces. Washable and long-lasting. Knit wrists. Color is yellow. Made in U.S.A.

<b>Part No.</b>	<b>Men's Size</b>	<b>Pkg</b>
21-273 .....	Medium .....	12 pr
21-274 .....	Large .....	12 pr

*Do not use near open flame or torch.*

## High Heat-Resistant Terry Kevlar® Gloves



**NEW ITEM!**

Top-notch protection from cuts and extreme heat — up to 900°F. Completely wool lined. Length: 14". Color is yellow. Made in U.S.A.

<b>Part No.</b>	<b>Pkg</b>
21-276 .....	1 pr

*Do not use near open flame or torch.*



# Work Gloves & Welding Coats

## Leather Welder's Gloves



All welder's gloves shown are, 14" overall length, one-piece back, seams and fingertips are fully welted to prevent burn-through. Men's size large. Made in U.S.A. **Economy**— for light-duty welding. Shoulder split leather. **Deluxe**— fully heat resistant for professional welders. Flexible side-split leather. **Aluminized**— same as deluxe welding gloves, except one-piece aluminized back and wool lined. Resists heat and UV radiation.

Part No.	Style	Color	Lining	Pkg
21-278	Economy	Gray	Cotton	6 pr
21-279	Deluxe	Rust	Acrylic	6 pr
21-280	Aluminized	Rust	Wool	1 pr

## Leather Palm Work Gloves

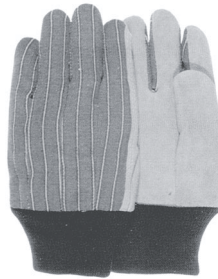

Select split leather palm, Cotton back, flannel lined, knit wrists. Men's size. Color is blue/gray. Imported.

Part No.	Pkg
21-281	12 pr



Select split leather palm, knuckle strap, finger tips, index finger, wing thumb. Flannel lined palm and thumb. Waterproof safety cuff. Men's size. Color is blue/gray. Imported.

Part No.	Pkg
21-282	12 pr

## Leather Drivers Gloves



Full leather, select buffed grain pigskin leather won't stiffen when wet. Provides longer wear and better breath-ability than cowhide. Unlined, elastic cuff, welted seams. Made in U.S.A.

**NEW ITEM!**

Part No.	Men's Size	Pkg
21-270	Medium	12 pr
21-271	Large	12 pr
21-272	Extra-Large	12 pr

## Green Welder's Coats



**NEW ITEM!**

Flame retardant. Cool and lightweight protection from sparks, splatters and low heat. Washable 100% cotton. Pkg: 1 each.

Part No.	Men's Size	Length
21-283	Medium	30"
21-284	Large	30"
21-285	Extra-Large	30"

*Also available: Flame retardant jackets, lined vests, waist and bib aprons, cape sleeves and leather garments.*

VISIT OUR WEBSITE  
[mpi-online.com](http://mpi-online.com)

FAX ANYTIME!  
**219-696-6413**

# Work Gloves

## Flock-Lined Natural Latex Gloves



Designed for housekeeping chores, natural latex rubber provides excellent comfort and dexterity, good chemical resistance and long-lasting service. Flocked lining for easy removal. Smooth finish.

Part No.	Men's Sizes	Pkg
21-487 .....	8 - Medium .....	12
21-488 .....	9 - Large .....	12
21-489 .....	10 - X-Large .....	12

## Disposable Latex Gloves

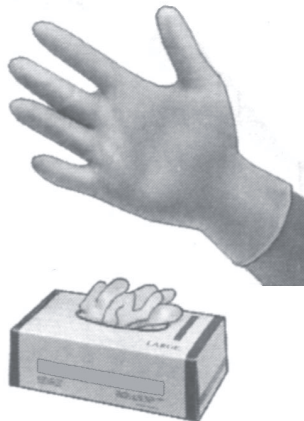

Ambidextrous, lightly powdered. 100 gloves per dispenser package. Imported. *Not for medical use.*

Part No.	Size	Unit
23-400 .....	Small .....	1 pkg
23-401 .....	Medium .....	1 pkg
23-402 .....	Large .....	1 pkg
23-403 .....	Extra-Large .....	1 pkg

## Neoprene Liquid Proof Gloves



Neoprene coated liquid proof glove provides best protection of all the coatings available. Protects against abrasion and chemicals. Unaffected by oil, acids, caustics, alcohols, detergents and most solvents. The 18" size protects up to the elbow. The 31" size protects entire arm, up to the shoulder. Cotton lined for added comfort and easy removal. Ozone resistant. Black, smooth finish. USDA accepted. Men's size. Made in U.S.A.

Part No.	Length	Cuff	Pkg
21-265 .....	10" .....	Knit wrist .....	12
21-266 .....	12" .....	Gauntlet .....	12
21-267 .....	14" .....	Gauntlet .....	12
21-268 .....	18" (elbow) .....	Gauntlet .....	6
21-269 .....	31" (shoulder) ...	Gauntlet .....	6

## WRIGHT TOOLS



Call us for a free catalog!



# Bolt Cutters



**RIDGID**

Ridge Tool's Center-Cut Bolt Cutters make quick and easy cuts on rod, wire mesh, concrete form ties, cable and bolts. Cam/bolt mechanism allows easy adjustment. Made in U.S.A.

Size	Max. Capacity		PART NUMBER	
	@31RC†	@42RC‡	Bolt Cutter	Repl. Head Assembly
14"	1/4"	3/16"	21-237	21-237RH
18"	5/16"	1/4"	21-238	21-238RH
24"	3/8"	5/16"	21-241	21-241RH
30"	1/2"	3/8"	21-243	21-243RH
36"	9/16"	7/16"	21-245	21-245RH
42"	5/8"	1/2"	21-247	21-247RH

†Iron and steel wire, proof coil chain, grade 5 bolts  
 ‡Stainless steel, high-test chain, spring wire, heat-treated rod, alloy bolts, reinforcing rod.

# Pipe Wrenches

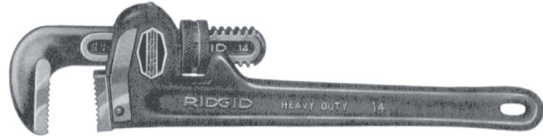

*Straight Pipe Wrench with Cast Iron Handle*



*Straight Pipe Wrench with 40% Lighter Aluminum Handle*

**RIDGID**

Each tool is work tested to assure the consistent quality you expect from Ridgid®. Handle is sturdy I-beam construction with comfortable contoured grip. Lifetime guaranteed\*. Made in U.S.A.

Size	PART NUMBER	
	Cast Iron Handle	Aluminum Handle
6"	21-249	-
8"	21-250	-
10"	21-251	21-257
12"	21-252	-
14"	21-253	21-258
18"	21-254	21-259
24"	21-255	21-260
36"	21-256	21-261

\*Lifetime guarantee applies to handle only. Jaws and all other parts are replaceable, but not guaranteed.

# Aviation Snips

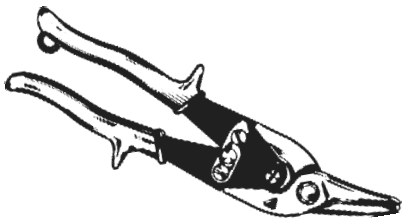

Effortlessly cut up to 18 gauge (.049") sheet metal with powerful compound action. Safety thumb latch and spring handle. Color-coded vinyl grips. Length: 9¾". Made in U.S.A.

Part No.	Direction of Cut	Grip Color
10-733	Left	Red
10-734	Right	Green
10-735	Straight	Yellow
10-736	3 Piece Set (one each of above)	

# Wire Rope Cutter



Cuts steel and stainless steel wire rope, aircraft cable, copper and aluminum wire, and iron rod. Sharp hardened (60 HRC) precision ground cutting edges are factory tested. Angular blades designed for clean cutting of wire, ropes, and steel cables without crushing or fraying ends. Material: tool steel, oil-hardened. Ergonomic design. Overall length: 7½". Plastic coated handles. Cutting capacity: wire and cable to 1/4", steel rod to 3/16". Made in Germany. **Part No. 10-395**





Possibly the only screwdriver you will ever need! Patented rotating design speeds use, saves palms! Quick-change bit system puts the 1/4" hex shank drive bits right at your fingertips! Seven industrial quality driver bits included. Color is black/orange. *Lifetime guaranteed (excluding driver bits).* Made in U.S.A. **Part No. 23-318**

### MEGAPRO REPLACEMENT BITS



Our Part No.	Description	Mfr's Part No.	Pkg Qty
23-318A	#4 - #6 Slotted	F4-F6	6
23-318B	#1 - #2 Phillips	P1-P2	6
23-318C	#0 - #3 Phillips	P0-P3	6
23-318D	T10 - T15 Torx	T10 - T15	6
23-318E	T20 - T25 Torx	T20 - T25	6
23-318F	#1 - #2 Square	S1 - S2	6
23-318G	#0 - #3 Square	S0 - S3	6

## 6-In-1 Screwdriver

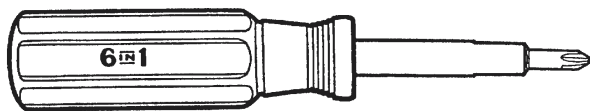

1/4" Slotted Bit  
3/16" Slotted Bit

1/4" Nut Driver  
5/16" Nut Driver

#2 Phillips Bit  
#1 Phillips Bit

Chrome-nickel plated hex tube reverses in handle. Industrial quality heat-treated hex bits at your fingertips! Wide handle for better, more comfortable grip! Handle color bright chartreuse. Made in U.S.A. **Part No. 10-690**

## TorqMAX Ratcheting Screwdriver



Swivels to any angle up to 180 degrees!

- 1/4" drive ratcheting head.
- Ball bearing arm hinge swivels up to 180° for extra torque.
- Super-sized handle for a big grip.
- Hi-Vis orange color is easy to find.
- Magnetic bit holder with bits in handle.

The TorqMAX will soon be the most popular tool in your collection. The oversized handle is made from a durable, high quality polymer. Twist-off the end cap of handle to find bit storage in the handle. 1/4" shank bit assortment includes: Phillips drive (#1,#2), Torx drive (T15,T20), flat blade (3/16,9/32) and square drive (#2). *Use with our 1/4" drive socket set (optional) for the ultimate nutdriver set.* Imported. **Part No. 10-749**

## Screwdriver Bit Kit

31 piece set includes magnetic screwdriver with storage in handle, bit holder, 8) torx bits, 4) phillips bits, 5 hex socket bits, 5) slotted bits, 4) square recess bits, 2) clutch bits and storage case. Imported. **Part No. 6782**



**NEW! 31 PC. SECURITY BIT KIT** Includes magnetic screwdriver with storage in handle, bit holder, 1/4" socket adapter, 10) security torx bits, 2) security phillips bits, 8) security hex socket bits, 4) security spanner bits, 2) square recess bits, 1) .250" slotted bit, 1) #1 phillips bit, and plastic storage case. Imported. **Part No. 6781**



# Snap Ring Pliers



## Standard Convertible

"Flip-over" to reverse. Easy to use attached knurled thumb screw. Comfortable vinyl cushion grips. Black oxide finish. Fully hardened steel. Straight tips not replaceable. Made in U.S.A. *Lifetime guarantee, excluding tips.*

Part No.	O.A. Length	Range Internal	Range External	Tip Dia.
10-616	5 <sup>3</sup> / <sub>4</sub> "	3/8" - 1.023"	1/4" - 7/8"	.038"
10-617	8"	1 <sup>1</sup> / <sub>16</sub> " - 1 <sup>3</sup> / <sub>4</sub> "	15/16" - 1 <sup>7</sup> / <sub>16</sub> "	.070"



## Push Button Convertible

Fast conversion without disassembly. Straight and 90° tips supplied in 3 popular diameters. Vinyl cushion grips. Chrome finish. Made in U.S.A. *Lifetime guarantee, excluding tips.*

Part No.	Internal	External	Replacement Tip Set
WT-9H1221S	1/4" - 1"	1/8" - 1"	WT-9H1221RK
WT-9H1234	3/8" - 2"	1/4" - 2"	WT-9H1234RK

# Impact Driver

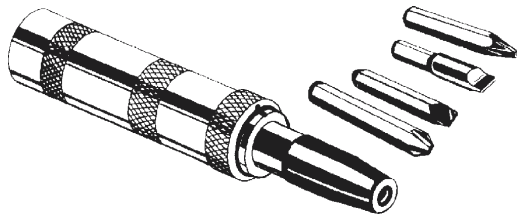

Loosen rusted or wedged tight screws and bolts. Twist the impact driver to set the cam, strike a sharp blow with a hammer, and the job is done. Set includes: 3/8" drive driver; 5/16" hex adapter; 4 heavy duty 5/16" insert bits (#1 and #2 phillips, 1/4" and 5/16" slotted). Made in U.S.A. **Part No. 10-649**

# Cobra™ Locking Pliers

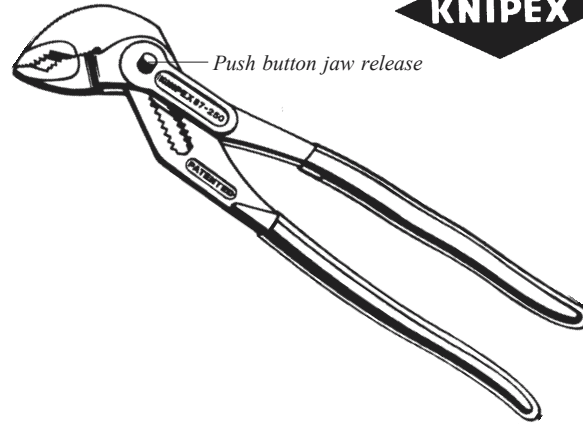

Push button jaw release for rapid single-handed adjustment. No need to open pliers to adjust the size! Selected opening is positively locked in place. Unique jaw design shaped to prevent nut-burring. Self-gripping jaws produce an iron grip on pipes, bolts & nuts. Extra thin jaws for easy access into tight work areas. Cushion grip handles. Lifetime guaranteed! Made in Germany.

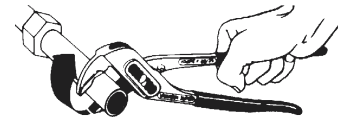

*Operates with one-handed downward pressure*

Part No.	Length	W.A.F.	Capacity	Pipe O.D.
23-300	7"	3/8"-1-1/8"		1/8"-1"
23-301	10"	3/8"-1-1/2"		1/8"-1-1/4"
23-302	12"	3/8"-1-7/8"		1/8"-1-1/2"
23-303	16"	3/8"-2-3/4"		1/8"-2-1/2"
23-309	3-piece set: contains 7", 10" & 12" pliers			

# Pry Bar Set

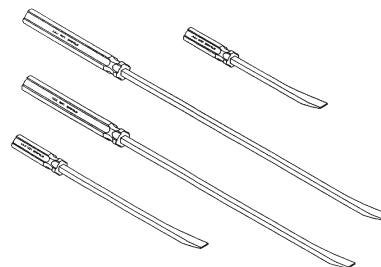

Ideal for prying stubborn flanges, cylinder heads, manifolds, transmission cases and more. 4 piece set includes 11", 16<sup>1</sup>/<sub>2</sub>", 26", and 32" long prybars. Forged and heat treated alloy steel. Black oxide finish. Red plastic handles. Conditional warranty. Made in U.S.A. **Part No. 99-178**

# Wiring Tools

## Multi-Purpose Crimping Tool

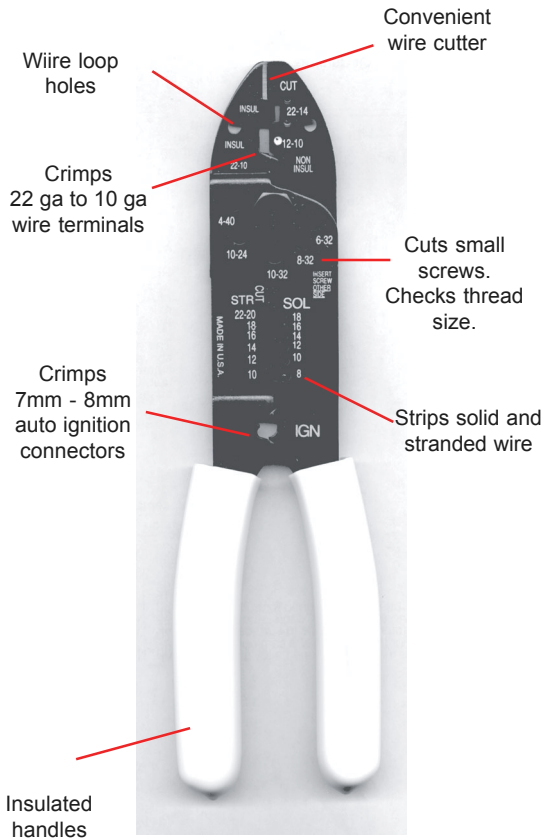

Top quality crimper, wire cutter, wire stripper and small bolt cutter all in one! Yellow insulated grips. Length is 8½". Made in U.S.A. 90-day warranty (against defects, not normal wear). **Part No. 23-305**

## The Easy Stripper™ (Automatic Wire Stripper)

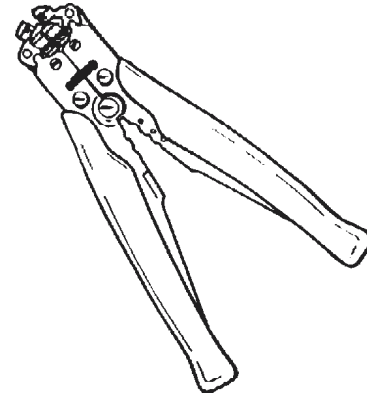

The fast way to strip wire is automatically! The Easy Stripper self-adjusts from 12 to 26 gauge wire, solid or stranded. Heavy duty design. Also has a built-in wire cutter and crimper. Insulated grips. *Limited 90-day warranty against defects.* Imported. **Part No. 23-306**

## CHANNEL LOCK Crimping Tool



A favorite among electricians and mechanics. Securely crimps insulated and non-insulated terminals with ease. Streamlined head permits work in confined space. Crimps 10 to 22 AWG. Wire cutters in nose cuts solid or stranded electrical wires. Channellock blue® insulated handles. Length is 9¾" for powerful leverage. Lifetime warranty. Made in U.S.A. **Part No. CN-909**

## CHANNEL LOCK

### Long-Nose Crimping Tool

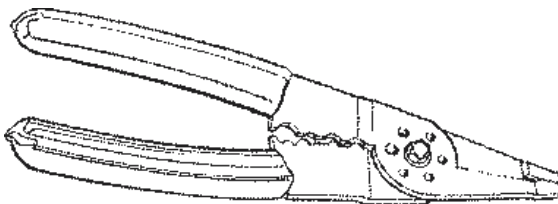

Narrow, serrated plier nose pulls, loops and bends wire ends. Pliers and cutters located in front to reach into tight areas. Crimps all terminals from 10 to 22 gauge. Cuts bolts. Blue insulated grips. *Lifetime guarantee!* **Part No. CN-908G**



Also see "Battery Terminal Crimpers & Tools"



# GearWrench™

## Ratcheting Combination Wrench Sets

The original GearWrench is a *speed wrench* that moves a fastener with the speed and ease of a fine tooth ratchet. The thin head & shank allow the to fit into the tightest areas. GearWrench needs as little as 5 degrees of sweep to move a fastener. A standard 12 point box end wrench needs 30 degrees of sweep— or 6 times as much

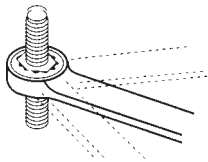

room. Long bolts and threaded rods are not a problem for the GearWrench. The ratcheting head allows the

wrench to travel the length of the threads without removing the box end from the fastener. Patented Surface Drive® box-end configuration virtually eliminates the rounding of fasteners. By moving the contact points of the wrench back from the edge of the fastener, the area of flat contact is expanded, distributing the load over a wider area. GearWrench meets or exceeds ANSI, DIN and federal torque specifications. Fully hardened all steel construction. Bright mirrored finished, nickel-chrome plated. Lifetime guaranteed! Imported.

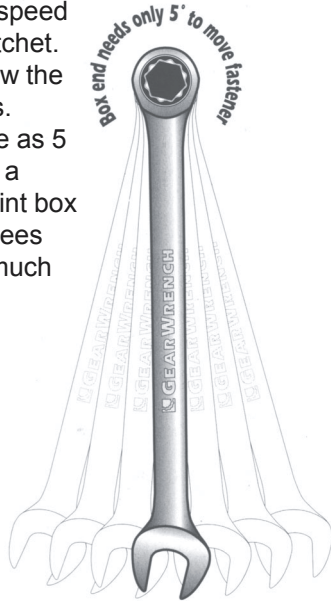

### STANDARD SETS

**4 PIECE SET** includes one each: 3/8", 7/16", 1/2", 9/16" (carded). **Part No. KD-9304**

**7 PIECE SET** includes one each: 5/16", 3/8", 7/16", 1/2", 9/16", 5/8", 3/4" wrenches in plastic molded case. **Part No. KD-9307**

### METRIC SETS

**4 PIECE SET** includes one each: M10, M12, M13, and M14 (carded). **Part No. KD-9404**

**7 PIECE SET** includes one each: M8, M10, M12, M13, M14, M15, M18 metric wrenches in plastic molded case. **Part No. KD-9407**

*Individual sizes available on request.*

# ToolZai™ Pro

## 12-in-1 Multi-Tool



Ideal for the professional on the go! Includes 12 of the most commonly used tools. Compact size-4" folded. Needle-nose pliers, wire pliers, wire cutter, 2 flat head screwdrivers, phillips screwdriver, serrated sheepfoot blade, drop point blade, metric/english ruler, lanyard ring, can/bottle opener, metal/wood file, ballistic sheath. All stainless steel. *Limited lifetime warranty!* Made in U.S.A. **Part No. 10-722**

## CHANNEL LOCK

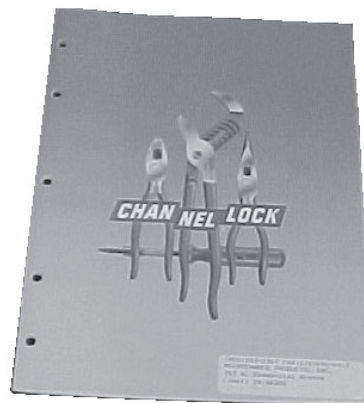

Ask your MPI representative  
for a free catalog!

# Shovels and Scoops

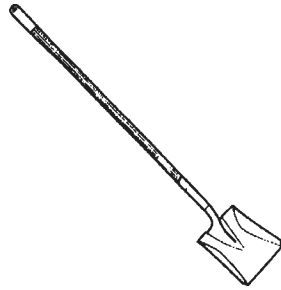

**Long Handle  
No. 2 Square Point Shovel**

Part No.	Length	Blade Size	Pkg Qty
AM-15545	46"	9" x 10½"	1

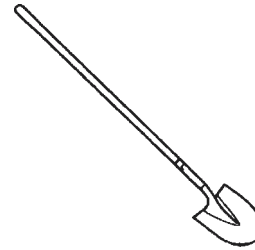

**Long Handle  
No. 2 Round Point Shovel**

Part No.	Length	Blade Size	Pkg Qty
AM-15543	46"	8¾" x 11"	1



**Power "D" Handle  
No. 2 Square Point Shovel**

Part No.	Length	Blade Size	Pkg Qty
AM-15544	29"	9" x 10½"	1



**Power "D" Handle  
No. 2 Round Point Shovel**

Part No.	Length	Blade Size	Pkg Qty
AM-15546	29"	8¾" x 11"	1



**Power "D" Handle  
No. 2 Garden Spade**

Part No.	Length	Blade Size	Pkg Qty
AM-15540	29"	6-7/8" x 12"	1

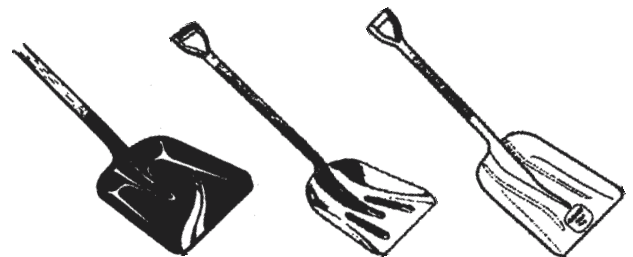

**"D" Handle Scoops**

Part No.	Length	Blade Size	Pkg Qty
NO. 6 STEEL SCOOP			
AM-13119	27"	12" x 17"	1
NO. 8 STEEL SCOOP			
AM-13120	27"	14" x 17"	1
NO. 10 ALUMINUM SCOOP			
AM-16710	27"	14¾" x 18"	1
NO. 12 ABS PLASTIC GRAIN SCOOP			
AM-16800	27"	14¼" x 19"	1



**Deluxe Socket Pattern  
Long Handle Ice Scraper**

Part No.	Length	Blade Size	Pkg Qty
AM-16463	48"	7" x 6"	1

*Rakes, hoes and snow shovels available on special request. Call our office for details.*



# Air Guns and Attachments

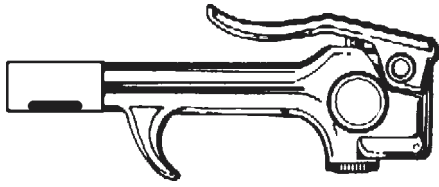

## Safety Blow Gun

Slotted venturi tip prevents pressure build-up. Venturi effect draws more air than standard blow guns...air consumed; 11 CFM, air delivered; 16 CFM. Lever handled valve. Hang-up hook. Inlet: 1/4NPT, Outlet: 1/8 NPT. Compatible with accessories listed on next page. Made in U.S.A. *Complies with OSHA 1910.242b & 1910.95 requirements when used on an air line of 150 PSI or less.* **Part No. 12-208**

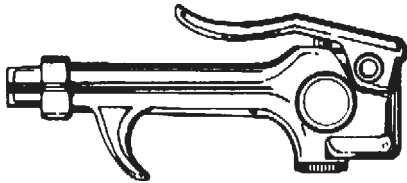

## Standard Blow Gun\*

Air consumed and delivered; 8 CFM. Lever handled valve. Hang-up hook. Inlet: 1/4NPT, Outlet: 1/8 NPT. Compatible with accessories listed on next page. Made in U.S.A. *This gun must be used on regulated air line of 30 psi or less to conform to OSHA 1910.242b requirements\*.* **Part No. 12-200**

### \*WARNING - NO SAFETY BYPASS

Do not block the tip. Always wear eye protection and personal protective equipment when using blow guns. Do not point the tip at people or animals when using compressed air, keep the tip pointed away from your body. Failure to follow these specifications and warnings exactly may result in personal injury and/or property damage.



## 12-223T / Siphon Spray Gun

Blows for liquid cleaners to degrease auto engines and equipment. Also can be used as a blow gun. Has control valve to regulate density of mist. Complete with 8-foot plastic suction tube. **Part No. 12-223T**



*Rubber Air Gun Tip  
1/8" NPT.  
Part no. 12-202\**



*Standard Air Gun Tip  
1/8" NPT.  
Part no. 12-200T\**



*Flexible Air Gun Extension  
Length: 8", 1/8" NPT.  
(Also use for cutting tool coolant line)  
Part no. 12-202\**

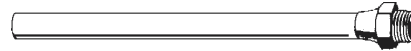

*Rigid Air Gun Extension  
Length: 6", 1/8" NPT. Chrome plated.  
Part no. 12-200E6\**

### \*WARNING - NO SAFETY BYPASS

Do not block the tip. Always wear eye protection and personal protective equipment when using blow guns. Do not point the tip at people or animals when using compressed air, keep the tip pointed away from your body. Failure to follow these specifications and warnings exactly may result in personal injury and/or property damage.

When Parker Pen marketed a ball-point pen in Mexico, its ads were supposed to have read, "It won't leak in your pocket and embarrass you." The company thought that the word "embarazar" (to impregnate) meant to embarrass, so the ad read, "It won't leak in your pocket and make you pregnant."

## Air Hose Caddy with Air Hose



Durable, lightweight and portable! Used by contractors everywhere! Anyone with a compressor can save time work safe! Comes with flexible 3/8"ID yellow PVC air hose with 300 psi rating. Includes 1/4 NPT male hose ends. Excellent for construction and service vehicles. Wall-mountable. Made in U.S.A.

Part No.	Hose Length	Total Weight	Pkg
HC-38100 .....	100 ft. ....	20 lbs. ....	1
HC-38150 .....	150 ft. ....	25 lbs. ....	1

*Steel retractable reels available upon special request.*

## Heavy Duty Pump Oilers

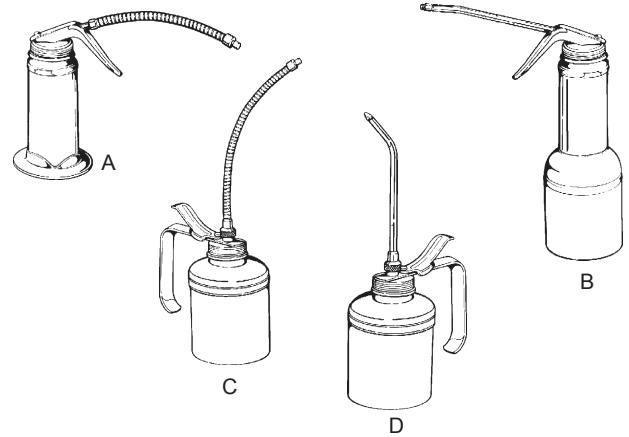

Oilers are available in pistol and handled models. Just squeeze trigger to deliver a single drop or a steady stream of oil. Body is made of seamless steel with a rust resistant epoxy finish. Zinc plated spouts.

Fig.	Part No.	Capacity	Handle	Spout
A. ....	12-50519 .....	6 oz. ....	Pistol Grip ...	6" Flex
B. ....	12-50525 .....	16 oz. ....	Pistol Grip ...	6" Rigid
C. ....	12-50437 .....	16 oz. ....	Handled .....	9" Flex
D. ....	12-50436 .....	16 oz. ....	Handled .....	9" Rigid

## Polyethylene Gas Cans



Made from high density polyethylene. Dent and corrosion resistant. Sturdy molded handle. Furnished with self storing flexible spouts. Meets Dept. of Public Safety and UL approvals. Recommended for outdoor use only.

Part No.	Capacity	Pkg
29-479 .....	1-1/4 gallon .....	1
29-480 .....	5 gallon .....	1

## Metal Gas Can



Metal can for use with gasoline only. Convenient self-storing plastic spout with extension. Recommended for outdoor use only.

Part No.	Capacity	Pkg
29-482 .....	1 gallon .....	1

## Galvanized Measures



Durable, corrosion resistant and leakproof. Use with any fluid, except strong acids. Hot-dipped galvanized steel. Made in U.S.A.

Part No.	Capacity	Pkg
RIGID SPOUT		
12-75401 .....	1 quart .....	1
12-75402 .....	2 quart .....	1
12-75404 .....	4 quart .....	1
FLEXIBLE SPOUT		
12-75441 .....	1 quart .....	1
12-75442 .....	2 quart .....	1
12-75444 .....	4 quart .....	1

## Metal Funnel

Sturdy utility funnel for all-purpose use. Rimless, solid tin. Has ring on the lip for reinforcement.

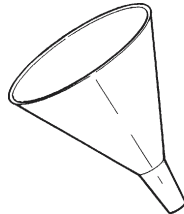

Part No.	Capacity	Diam.	Pkg
12-75009 .....	10 oz. ....	4-1/2" .....	1
12-75010 .....	24 oz. ....	5-3/4" .....	1
12-75011 .....	32 oz. ....	6-1/2" .....	1
12-75012 .....	56 oz. ....	8" .....	1

## Plastic Funnel

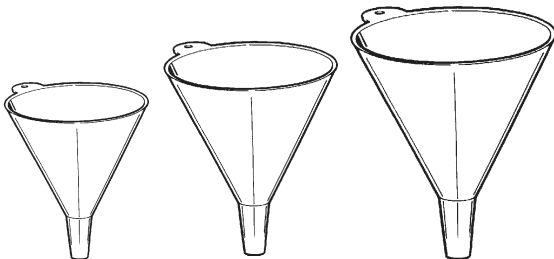

Part No.	Capacity	Diam.	Pkg
12-75060 .....	8 oz. ....	3-3/4" .....	5
12-75062 .....	16 oz. ....	5-1/2" .....	5
12-75064 .....	48 oz. ....	7-1/2" .....	5

## Plastic Recovery Drain Pan

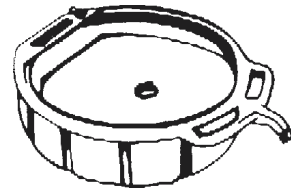

A drain pan and large capacity storage container all-in-one, with carry handles and easy pour spout. Includes plugs for transporting to a recycling center. 3.75 gal. capacity. **Part No. 12-084**

## Steel Drain Pan



Full drawn, galvanized steel. For oil, transmission fluid, coolant, etc.. No seams. Rolled edge. Capacity is 2½ gallons. **Part No. 12-087**

## Extention Funnel



15" flexible metal tube extension is perfect for hard-to-reach places like transmissions. Mesh strainer screen. Hot-dipped galvanized steel. Diameter: 5-3/4". **Part No. 12-086**

## Tractor Funnel



10" diameter funnel designed for filling tractors and heavy equipment with diesel fuel. Large 8 quart capacity. Galvanized steel with brass screen. **Part No. 12-085**



# Pin Punches

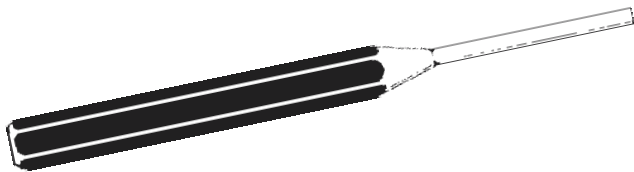

Designed to drive out straight and tapered pins only after loosening or starting object with a solid punch. Made in U.S.A.

Part No.	Point	Length	Hex Stock
10-413	1/16	4"	1/4
10-414	3/32	4-1/2"	1/4
10-415	1/8	5"	5/16
10-416	5/32	5-1/2"	3/8
10-417	3/16	5-1/2"	3/8
10-419	1/4	7"	1/2
10-420	5/16	7"	1/2
10-421	3/8	7"	5/8

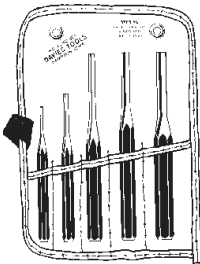

**5 PC. PIN PUNCH SET**  
1/8, 3/16, 1/4, 5/16, 3/8 PIN  
PUNCHES IN VINYL POUCH.  
**PART NO. 10-422**

# Solid Punches



Heavy design for loosening or installing pins. Finish driving pins out with Pin Punches (above). Made in U.S.A.

Part No.	Point	Length	Hex Stock
10-398	1/16	4"	1/4
10-399	3/32	4-1/2"	1/4
10-400	1/8	5-1/2"	3/8
10-401	5/32	5-1/2"	3/8
10-402	3/16	7"	1/2
10-403	1/4	7"	1/2
10-404	5/16	7"	1/2

# Roll Pin Punches

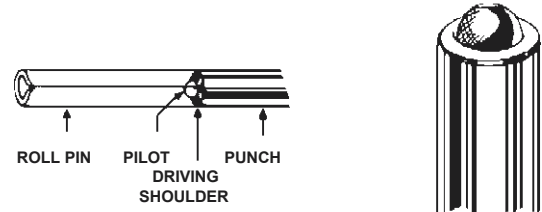

Specially designed to insert or remove Roll Pins without damage. Pilot point fits into the hollow center of pin so that the shoulder of punch is in perfect position for use. Made from forged, hardened and tempered steel. Made in U.S.A.

Part No.	Point Diameter	Pin Length	Overall Length
10-424	1/8	2"	4"
10-425	5/32	2-1/2"	4-1/2"
10-426	3/16	2-1/2"	4-1/2"
10-427	7/32	3"	5"
10-428	1/4	3-1/2"	5-1/2"
10-429	5/16	4"	6"

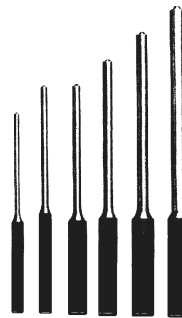

**ROLL PIN PUNCH SET**  
1/8, 5/32, 3/16, 7/32, 1/4, 5/16  
IN VINYL POUCH. **PART NO. 10-418**

VISIT OUR WEBSITE  
**mpi-online.com**

FAX ANYTIME!  
**219-696-6413**



# Cold Chisels



Use for cutting, shaping and removing metal such as cast iron, wrought iron, steel, brass, copper, and aluminum.

Part No.	Cut	Length	Hex Stock
10-385	1/4	4"	1/4
10-386	3/8	5"	1/4
10-387	7/16	5-1/2	3/8
10-388	1/2	5-1/2	3/8
10-389	5/8	6"	1/2
10-390	3/4	7"	5/8
10-391	7/8	7-1/2	3/4
10-392	1"	8"	7/8

**5 PC. CHISEL SET**  
3/8, 7/16, 5/8, 3/4, & 7/8 CHISELS  
WITH VINYL POUCH. **PART NO. 10-397**

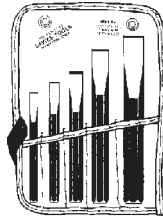

**5 PC. PUNCH AND CHISEL SET**  
7/16, 5/8 CHISELS, 3/8 CENTER  
PUNCH, 5/32 PIN PUNCH, 5/32 SOLID  
PUNCH, WITH VINYL POUCH.  
**PART NO. 10-423**

# Transfer Punch Set



Perform location transfers of threaded, drilled or tapped holes. Simply position workpiece with holes over the new piece that requires identical. Select correct diameter punch for the hole and tap with a hammer to mark the exact position for drilling. 28 pieces: 3/32" to 1/2" by 64ths plus 17/32" diameter. Metal stand included. Made in U.S.A. **Part No. 10-432**

*Larger fractional sets, letter sets, wire gauge sets and metric sets available on request.*

# Center Punches



Widely used in metal layout work for marking center lines, hole locations, and drill starting points.

Part No	Length	Hex Stock
10-411	4-1/2	3/8
10-412	5-1/2	1/2

# Alignment Punches

*(Drift or Taper Punch)*



Widely used to align holes in two or more pieces of metal to be bolted together. Also installs and removes pins and shafts.

Part No.	Point	Taper	Length
10-406	1/8	3-1/2	9"
10-407	3/16	4-1/2	11"
10-408	7/32	4-1/2	12"
10-409	1/4	4-1/2	12"



**3 PC. ALIGNMENT PUNCH SET**  
1/8, 5/32, 3/16 PUNCHES IN VINYL  
POUCH. **PART NO. 10-430**

# Safety Grip for Chisels

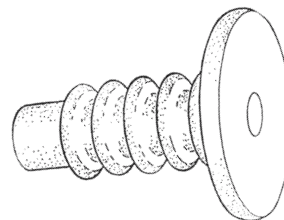

Reduces risk of worker injuries to hands. Easy to install on any 1/2" to 1" shaft chisels. Withstands the heaviest hammer blows. Will not conduct the cold, so it helps keep hands warm in frigid weather.

**Part No. 10-431**

# American-Pattern Files



## Flat Machinists' File

Universally favored in the factory, machine shop and garage, this is the general purpose "work horse" used by all mechanics for rapid stock removal. Double cut, it tapers in width toward the point and has cut edges. Made in U.S.A.

Length	Part Number	
	Bastard Cut	Smooth Cut
6" .....	21-429 .....	21-434 .....
8" .....	21-430 .....	21-435 .....
10" .....	21-431 .....	21-436 .....
12" .....	21-432 .....	21-437 .....
14" .....	21-433 .....	21-438 .....



## Half-Round Machinists' Files

These files are used for filing out concave surfaces and crevices, and for rounding out holes. Their improved spiral cut enables them to remove metal rapidly and leave a smooth finish. Made in U.S.A.

Length	Part Number	
	Bastard Cut	Smooth Cut
6" .....	21-439 .....	21-443 .....
8" .....	21-440 .....	21-444 .....
10" .....	21-441 .....	21-445 .....
12" .....	21-442 .....	21-446 .....



## Mill Saw Files

This is one of the most generally used files because it is adaptable for so many purposes such as sharpening saws, shears, lawn mowers, axes, farm tools, etc., and for draw filing and general shop use. Tapers slightly in width. Furnished with both edges single cut. Made in U.S.A.

Length	Part Number	
	Bastard Cut	Smooth Cut
6" .....	21-447 .....	21-452 .....
8" .....	21-448 .....	21-453 .....
10" .....	21-449 .....	21-454 .....
12" .....	21-450 .....	21-455 .....
14" .....	21-451 .....	- .....



## Knife-Shaped Machinist's Files

Shaped like a knife blade, this file is commonly used on slots and keyways and for acute work in die making. Sides are double cut and the thin edge is cut but the back is safe (uncut). Made in U.S.A.

Length	Part Number	
	Bastard Cut	Smooth Cut
10" .....	21-457 .....	



## Round Machinists' Files

Designed for enlarging circular holes or rounded grooves, too small for a half round file, this is another popular machinists' file. It tapers toward the point making it adaptable for use on various size holes. Made in U.S.A.

Dia. x Length	Part Number	
	Bastard Cut	Smooth Cut
1/4 x 6" .....	21-458 .....	21-462 .....
5/16 x 8" .....	21-459 .....	21-463 .....
3/8 x 10" .....	21-460 .....	21-464 .....
1/2 x 12" .....	21-461 .....	21-465 .....



## Three Square Files

Triangular in shape, this file has 60° angles between sides and tapers toward the point. Double cut, it is used for cleaning out corners, filing internal angles inaccessible to rectangular shape files, and for filing annealed cutters and taps. Also used on flat surfaces. Made in U.S.A.

Length	Part Number	
	Bastard Cut	Smooth Cut
8" .....	21-466 .....	21-467 .....

**YOU ORDER TODAY, WE SHIP TODAY! WHY WAIT?**



## Files (Cont'd)



### Chain Saw File

Developed and perfected especially for sharpening round-hooded chain saw teeth, this file maintains proper tooth shape and leaves a smooth, keen cutting edge. Available in diameters and lengths shown for sharpening all sizes of saw chain. Single cut. Made in U.S.A.

Size	Part No.
1/8 x 6" .....	21-422
5/32 x 6" .....	21-423
3/16 x 8" .....	21-424
7/32 x 8" .....	21-425

## Universal File Handle



Use a file handle for safety and better results. Made from impact resistant plastic. Four tang inserts provided fit all tang shapes and sizes. Made in U.S.A. **Part No. 21-426**

## Thread Restoring Files

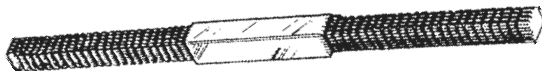

Restore battered, rusted and corroded threads quickly. Thread sizes marked on file. Size: 7/16 square x 8 1/2". Made in U.S.A.

Part No.	Threads Per Inch
21-427 .....	11, 12, 13, 14, 16, 18, 20, & 24
21-428 .....	9, 10, 12, 16, 20, 27, 28, & 32

## Caulking Guns



### Standard Caulking Gun

For use light to medium consistency caulks and sealants. Features standard ratchet rod and spout cutter. For 10-12 oz. cartridges. Import. **Part No. 21-301**

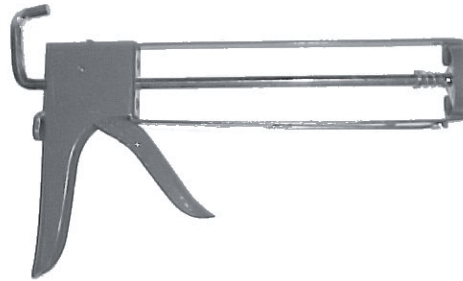

### Heavy Duty Caulking Gun

Skeleton frame caulking gun delivers 3 times more thrusting power than standard guns. Easily dispenses stiff caulks and sealants. Features seal puncture tool, spout cutter, heavy duty hex piston rod, quick pressure "thumb" release for fast shut-off. Ladder hook, E-Z load front cap and cartridge retainer spring. For 10-12 oz. cartridges. Import. **Part No. 21-302**

## Burring Reamers

Spiral flute burring reamers remove burrs from pipe, conduit and access holes. Used by repairmen, mechanics and plumbers. Made from forged high carbon heat treated tool steel. Round shank fits any 1/2" electric drill.



Part No.	Shank	Capacity	
		Max.	Min.
10-488 .....	1/2" .....	1/4" .....	1-1/2"
10-489 .....	1/2" .....	3/8" .....	2"

# 2 and 3 Jaw Gear Pullers

## 5 TON COMBINATION TWO & THREE JAW REVERSIBLE PULLER

Choose either a two point grip or a three point grip, where you need the extra stability and power of a three point pull. Has plain hook on both ends of jaws.

**Part No. 10-613**

Spread: 7"  
Reach: 3-1/2"  
Forcing Screw: 5/8 x 6"  
No. of Jaws: 2 or 3

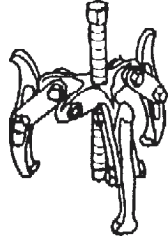

## 5 TON TWO JAW REVERSIBLE PULLER

Here is a very versatile puller, designed for maximum utility. The reversible jaws have a wide face on one end and narrow face on the other. Quickly completes most medium duty pulling tasks.

**Part No. 10-610**

Spread: 6"  
Reach: 3-1/2"  
Forcing Screw: 5/8 x 6"

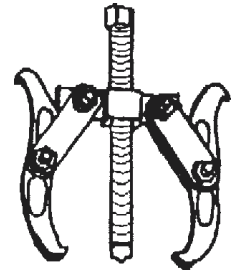

## 7 TON COMBINATION TWO & THREE JAW REVERSIBLE PULLER

Take your pick, either assemble the puller as a two jaw or three jaw puller. Sometimes the three point grip is all the extra pull needed for the job. Has slotted hooks on one end of jaws for hooking on to cap screws to remove gears of parts which have tapped holes.

**Part No. 10-614**

Spread: 10"  
Reach: 5-1/2"  
Forcing Screw: 3/4 x 8-5/16"

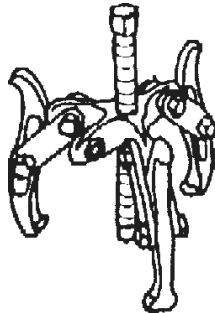

## 7 TON TWO-JAW REVERSIBLE PULLER

This heavy duty puller is designed for both automotive and industrial use. The jaws are reversible and one end has a slot for cap screw pulling of tapped gears and pulleys. Works very well with 10-608 bearing splitter.

**Part No. 10-611**

Spread: 9"  
Reach: 5-1/2"  
Forcing Screw: 3/4 x 8-5/16"

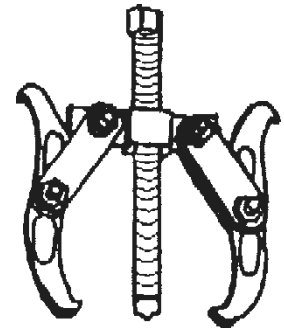

## 7 TON TWO-JAW ADJUSTABLE PULLER

The adjustable 3 position jaws make it adaptable to many uses including flywheel, gear, and pulley removal. This is a rugged, heavy duty puller.

**Part No. 10-612**

Spread: 10"  
Reach: 9"  
Forcing Screw: 3/4 x 8-5/16"

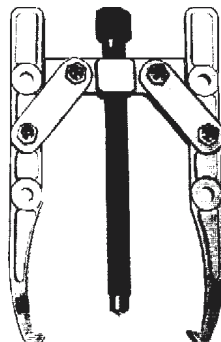

## 2 TON TWO-JAW ADJUSTABLE PULLER

This small, but rugged gear puller is designed to remove magneto and generator bearing gears. It is ideal for electric motors and refrigeration applications and light duty gear pulling.

**Part No. 10-609**

Spread: 4"  
Reach: 3-1/2"  
Forcing Screw: 3/8 x 4-1/4"

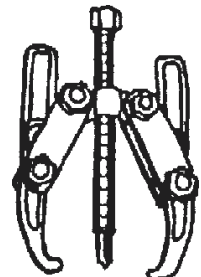

# Bearing Separator

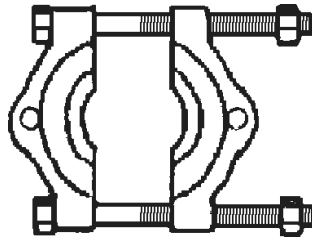

Threaded holes are 5/8-18. May be used with puller no. 10-611. For removing generator gears, bearing cones, bearings, and other parts that puller jaws cannot reach, knife edges are flush. Capacity: 0" to 4-1/4"

**Part No. 10-608**

# Harmonic Balancer Puller

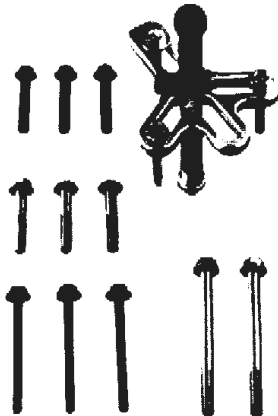

For most automobiles, large and small, foreign and domestic. Will pull parts with tapped holes like fly wheels, gears, and pulleys. **Part No. 10-607**

Includes 5 sets of side bolts:

- 2 each 3/8-16 x 4"
- 3 each 3/8-24 x 2"
- 3 each 5/16-18 x 2"
- 3 each M8 x 1.25 x 80mm
- 3 each M10 x 1.50 x 50mm



# Marking Tools

*(Steel Hammer Stamps)*

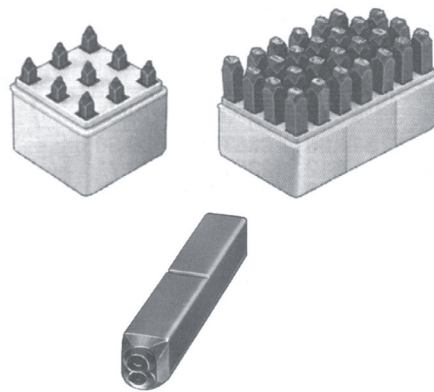

ACTUAL CHARACTER HEIGHT

5 <sup>3</sup>/<sub>32</sub>"      5 <sup>3</sup>/<sub>16</sub>"      5 <sup>3</sup>/<sub>8</sub>"  
 5 <sup>1</sup>/<sub>8</sub>"      5 <sup>1</sup>/<sub>4</sub>"

## LETTER SETS in Wooden Box

Each letter set is packaged in its own solid wooden box. Lid doubles as a holder for composition. Letter sets consist of 27 stamps; letters A through Z and a period.

Part No.	Character Height
10-651	3/32"
10-653	1/8"
10-655	3/16"
10-657	1/4"
10-659	3/8"

## FIGURE SETS in Wooden Box

Each figure set is packaged in a solid wooden box. Figure sets consists of 9 stamps; 0 through 8, the 6 also being used for the 9.

Part No.	Character Height
10-650	3/32"
10-652	1/8"
10-654	3/16"
10-656	1/4"
10-658	3/8"

# Folding Rule

## Stud mark every 16 inches

This wooden carpenters' rule is 6 foot long and 5/8" wide. Both sides are marked in 16ths of an inch, with red stud markings every 16 inches. Outside reading (numbering begins on top of slat). White finish. Made in U.S.A. **Part No. 10-668**

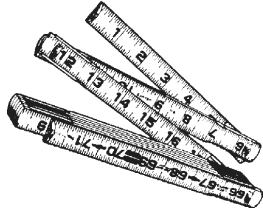

# Pocket Slide Caliper

A handy pocket slide caliper now made entirely of stainless steel with both inside and outside reading of measurements. The rule has easy reading graduations in 16ths and 32nds. For mechanics, servicemen, hobby-crafters, anyone who must occasionally measure small objects such as nails, screws, buttons, lenses, tubing, etc. Has a handy decimal equivalents table on back. Made of stainless steel.

### FRACTIONAL

Readings up to 5" in 16ths and 32nds. **Part No. 10-479**



### FRACTIONAL & METRIC

Readings up to 5" in 16ths and millimeters. **Part No. 10-480**

# Vernier Calipers

Inside and outside vernier caliper, with depth Gauge. Friction roller permits simple, yet sensitive adjustment. Caliper may be locked at any desired position for gaging purposes. Made of nickel plated steel.

### FRACTIONAL

Readings up to 5" in 16ths and 32nds, with a vernier reading of 1/128th. (half of 1/64th) **Part No. 10-477**

### FRACTIONAL & METRIC

Readings up to 5" in 16ths and millimeters. **Part No. 10-478**

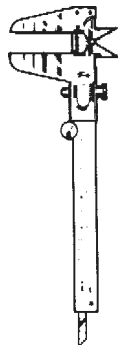

*Vernier Calipers also available in Stainless Steel and Plastic*

# Tape Measures



Popular brand. High impact plastic case fits comfortably in your hand. All blade returns cushioned by shock absorber. Cam activated lock prevents blade from slipping back. Hi-Vis yellow spring steel blade is easy to read. Steel pocket clip. The 25 foot rules have a 3" base for easy inside measurements. Made in U.S.A..

Part No.	Size	Pkg
21-350	1/2 x 12'	6
21-351	3/4 x 12'	6
21-352	3/4 x 25'	6
21-353	1" x 25'	6

# Extra-Wide Tape Measure



## Extends to 11 feet without support!

High impact plastic case fits comfortably in your hand. Blade return cushioned by shock absorber. Cam activated lock prevents blade from slipping back. Hi-Vis yellow spring steel blade is easy to read. Steel pocket clip. The 25 foot rules have a 3" base for easy inside measurements. Color: orange. Imported.

Part No.	Size	Pkg
10-667	1-1/4" x 25'	1



# Screw Gauges & Thread Pitch Gauges

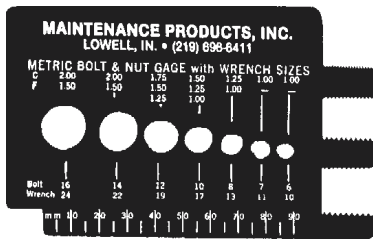

## Metric Bolt & Nut Gauge

Just push the bolts through the holes to find diameter. Measures hex head of bolts for wrench size and/or diameter of fastener. Thread pitch gauge quickly measures five thread pitches. **Part No. 42-003**

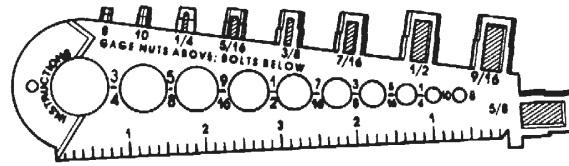

## U.S. Standard Bolt & Nut Gauge

Easiest to use... shirt-pocket size! Just push the bolts through the holes to find diameter. Measures regular and countersunk heads. Nuts drop on plugs along top edge of Gauge. NF nuts fit to base of plugs, NC nuts fit half-way. **Part No. 42-000**

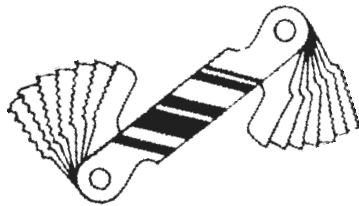

## Metal Screw Pitch Gauges

### LARGE U.S. STANDARD PITCH

Measures pitch sizes from 4 to 84, including 11-1/2 and 27 pipe thread. 51 pitches. Gauges V, American National and U.S.S. 60° threads. **Part No. 10-472**

### SMALL U.S. STANDARD PITCH

Measures pitch sizes from 9 to 40, including 11-1/2 and 27 pipe thread. 22 pitches. Gauges V, American National and U.S.S. 60° threads. **Part No. 10-473**

### METRIC PITCH GAUGE

Measures pitch sizes from .25 to 6mm. 24 pitches. **Part No. 7070**

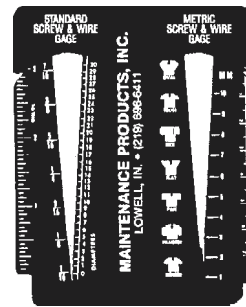

## Combination Inch & Metric Screw Gauge

To use, hold small screws at an angle in slots to find diameter. Measures regular and countersunk heads. **Part No. 42-002**



## Copper Wire/Battery Terminal Gauge

Determines the correct size of copper wire from 10 to 4/0 gauge. Simply insert bare wire into the "V" section of the tool to identify what gauge wire it is. This sturdy plastic tool includes a feature for identifying the correct wire size of battery terminal compression nuts. **Part No. 42-001**

## 'O' Ring Sizing Cone

Sizes O-rings with standard AS568A-dash numbers up to 8" ID. Includes pi tape for measuring large sizes.

**Part No. 20-1007**

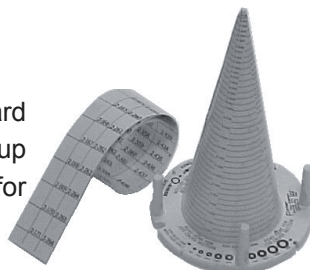



## Tubing Cutters

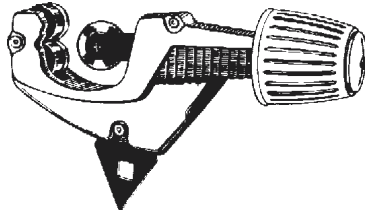

**LARGE TUBING CUTTER** includes two steel cutter wheels (one stored in knob) and a retractable reamer. Capacity: 1/8" - 1-1/8". **Part No. 10-463**



**MIDGET TUBING CUTTER** for hard to get at places. Needs only 1-1/4" clearance. Capacity: 1/8" thru 5/8" **Part No. 10-444**



**REPLACEMENT CUTTER WHEELS**  
One size fits all the above tubing cutters. **Part No. 10-490**

## Plastic Tubing Cutter

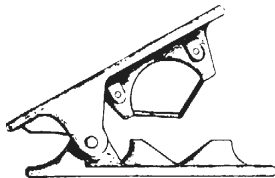

Razor sharp blade cuts small plastic and vinyl tubing and non-wire reinforced hose up to 9/16" OD. **Part No. 23-317**

## Deluxe Hose Cutter



Length is 9 3/4" for extra leverage. Razor sharp blade cuts plastic and vinyl tubing and non-wire reinforced hose up to 1-1/8" OD. All metal construction. Comfortable PVC coated handles. Made in Canada. **Part No. 10-393**

Replacement Blades: Part No. 10-394

## Flaring Tool Kit



*Completed double flare.*

**For Single & Double Flaring Steel, Copper, or Aluminum Tubing up to 1/2" OD**

Double flares most tubing materials, even soft steel. Will also single flare. High grade alloy steel swivel is precision ground and chromed to reduce friction. Each adapter is stamped with size. Comes with flaring tool, adapters for 3/16, 1/4, 5/16, 3/8, 1/2" tubing, instructions and durable polyethylene box. Made in U.S.A. **Part No. 10-664**

## Heavy Duty Tubing Bender

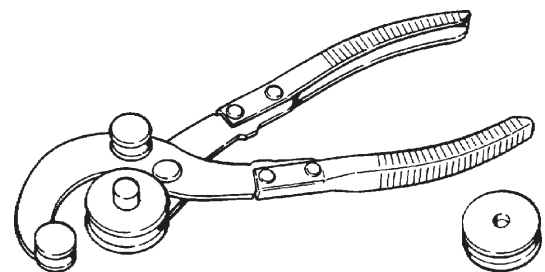

Bends 3/16, 1/4, 5/16, and 3/8" diameter copper and soft steel tubing. Makes tight bends without collapsing tubing. Roller adapters included for each tubing size. Place tubing between adapter and studs. Squeeze handles to bend. **Part No. 10-663**

# Tungsten Carbide Scribe with Magnet



Marks hard materials including hardened steel, ceramic and glass. Handy magnet picks up small parts, steel chips, etc. Length: 6".

Part No.	Description	Pkg Qty
10-484	Scriber	1
10-485	Replacement Points	1

# Steel Scribe



Ideal for etching hard metals and soft materials. Also use as an O-ring removal tool. Has straight and right angle hardened steel tips. Knurled aluminum body. 8-1/2" length. **Part No. 12-72443**

# Automatic Center Punch



Black oxide finish inhibits rust. All steel 5" body with threaded, replaceable hardened steel point and shaft. Body diameter is 1/2".

Part No.	Description	Pkg Qty
10-481	Automatic Center Punch	1
10-482	Replacement Points	1

# Drop Forged "C" Clamps

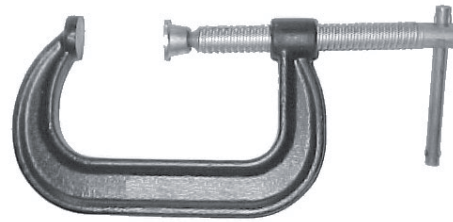

Heavy duty industrial quality clamp with copper coated stem for spatter-resistance. Made in U.S.A.

Part No.	Capacity		Throat Depth
	Max.	Min.	
10-669	4"	0"	2-3/4
10-670	6"	0"	3-5/8
10-671	8"	0"	4-1/2
10-672	10"	0"	5-3/8
10-673	12"	0"	5-3/4

# WISE-GRIP® QUICK-GRIP® Welding Clamp

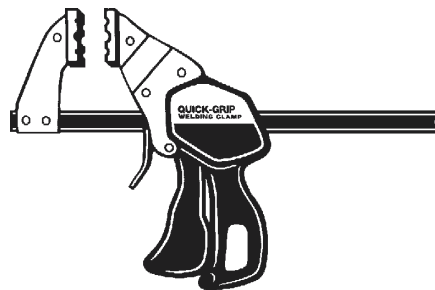

Perfect for quick-tacking and other welding jobs. Fast, one-handed pistol-grip operation revolutionizes clamping. Heat-treated carbon steel jaws. Spatter-resistant copper plated pads. Horizontal and vertical grooves in jaws allow easy clamping of round stock.

Part No.	Jaw Opening	Vise-Grip Stock No.
10-648	6"/150mm	05906



# WISE-GRIP®

## Locking Pliers

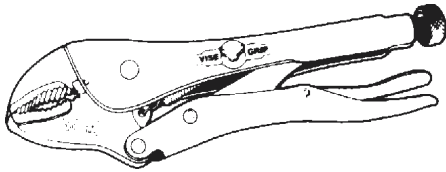

### CURVED JAW

For better contact on bolt heads, nuts, and round stock.

Part No.	Length	Jaw Opening	Vise-Grip No.
10-642	7"	1-5/8"	7CR
10-627	10"	1-7/8"	10CR

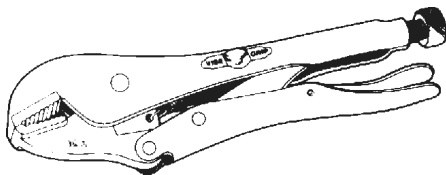

### STRAIGHT JAW

Part No.	Length	Jaw Opening	Vise-Grip No.
10-643	7"	1-1/8"	7R
10-628	10"	1-1/2"	10R

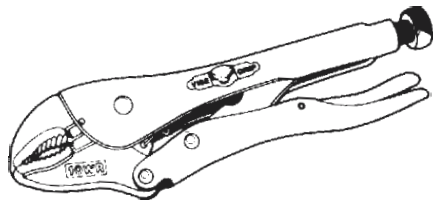

### CURVED JAW W/WIRE CUTTER

Part No.	Length	Jaw Opening	Vise-Grip No.
10-638	5"	1-1/4"	5WR
10-644	7"	1-5/8"	7WR
10-629	10"	1-7/8"	10WR

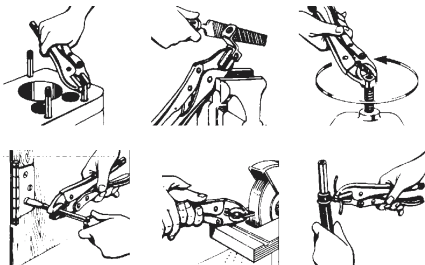

## Long Nose Locking Pliers with Wire Cutter

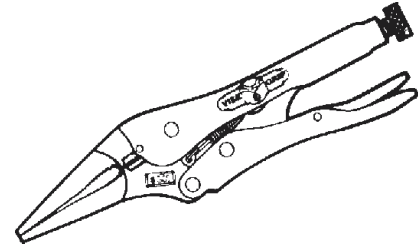

### STRAIGHT NOSE

jaws reach into tight spots where other tools can't.

Part No.	Length	Jaw Opening	Vise-Grip No.
10-639	6"	2-1/4"	6LN

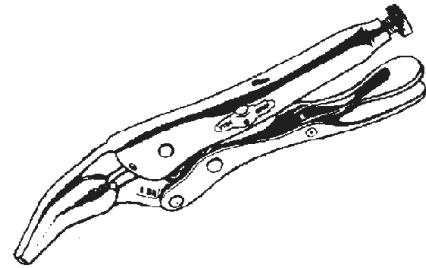

### BENT NOSE

Provides off-angle access to tight places.

Part No.	Length	Jaw Opening	Vise-Grip No.
10-674	6"	2-1/4"	6BN

## Large Jaw Locking Clamp



Especially use for those who work with large objects like exhaust system and oil filters.

Part No.	Length	Jaw Opening	Vise-Grip No.
10-646	12"	3-1/8"	12LC

# WISE-GRIP®

## Locking Wrench

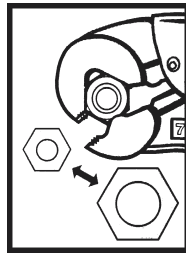

This 16-IN-1 locking wrench locks on to three flat sides of hex fasteners, allowing for tremendous force to be applied without marring or slipping off the fastener. Each locking wrench adjusts to 16 different standard and metric sizes. Equipped with wire cutter.

MPI PART NO.	ViseGrip Model	Description	Adjusts to Inch Sizes	Adjusts to Metric Sizes
#10-714	4LW	4" Locking Wrench	1/4" - 9/16"	7mm - 14mm
#10-715	7LW	7" Locking Wrench	7/16" - 3/4"	11mm - 19mm
#10-716	10LW	10" Locking Wrench	5/8" - 1-1/8"	15mm - 28mm
#10-721	248	3 piece Locking Wrench Set with storage pouch		

## Locking Chain Pipe Clamp

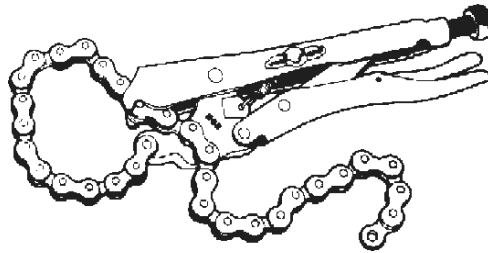

Holds and locks around any size or shape - anything the chain can be wrapped around. Adjusts to ratchet action in either direction. Won't slip, won't crush thin-walled pipe.

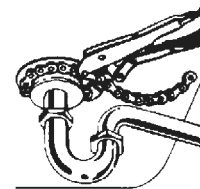
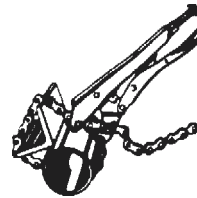

Part No.	Chain Length	Vise-Grip No.
10-634	19"	20R

## Locking C-Clamp

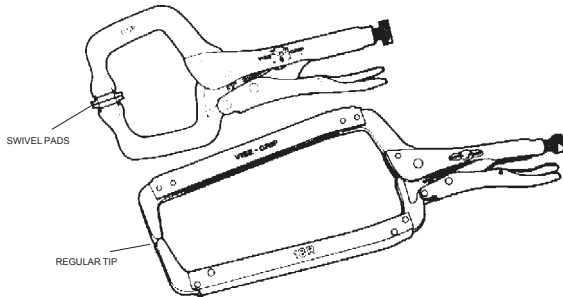

Perfect for welding and body repair shops. Available with self-leveling swiveling pads or regular tips. Locks to work with hand squeeze.

Part No.	Length	Throat Height	Grip Depth	Vise-Grip No.
<b>SWIVEL PADS</b>				
10-641	6"	2"	2"	6SP
10-631	11"	3-3/4"	2-5/8"	11SP
10-633	18"	4"	10"	18SP
<b>REGULAR TIP</b>				
10-640	6"	2"	2"	6R
10-630	11"	3-3/4"	2-5/8"	11R
10-632	18"	4"	10"	18R

## Locking Sheet Metal Tool



Locks to work with powerful grip for smooth and accurate bending and seaming. Micro-adjusting screw and easy release trigger.

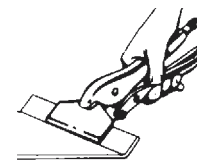
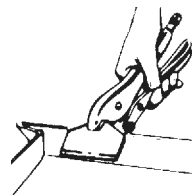

Part No.	Chain Length	Jaw Width	Vise-Grip No.
10-645	8"	3-1/8"	8R

# Power Bits

Heat treated tool steel. For use in drill chucks and "quick-release" chuck adapters.



## PHILLIPS

1/4" HEX SHANK, 2-3/4" LONG

Pkg: 10 each

Part No.	Point Size	Body Dia.	Apex* No.
6765	1	3/16	491-A
6766	2	1/4	492-A
6767	3	5/16	493-A

# Insert Bits

Heat treated tool steel. For use with magnetic bit holder (6767A) in drill chuck, cordless screwdrivers, or square drive magnetic hex bit holders.



## PHILLIPS

1/4" HEX SHANK, 1" LONG

Pkg: 10 each

Part No.	Point Size	Apex* No.
6723	1	440-1
6724	2	440-2
6725	3	440-3

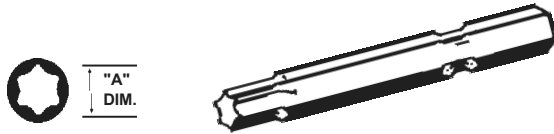

## TORX

1/4" HEX SHANK, 1-15/16" LONG

Pkg: 10 each

Part No.	Point Size	"A" Dim.	Apex* No.
6783	T27	.195"	TX27-3
6784	T30	.216"	TX30-3
6785	T40	.260"	TX40-3

# Screwdriver Bit Kit

31 piece set includes magnetic screwdriver with storage in handle, bit holder, 8) torx bits, 4) phillips bits, 5 hex socket bits, 5) slotted bits, 4) square recess bits, 2) clutch bits and storage case. Imported.



**Part No. 6782**

**NEW! 31 PC. SECURITY BIT KIT** Includes magnetic screwdriver with storage in handle, bit holder, 1/4" socket adapter, 10) security torx bits, 2) security phillips bits, 8) security hex socket bits, 4) security spanner bits, 2) square recess bits, 1) .250" slotted bit, 1) #1 phillips bit, and plastic storage case. Imported. **Part No. 6781**

*\*For reference only. Not an Apex product.*



## TORX

1/4" HEX SHANK, 1" LONG

Pkg: 10 each

Part No.	Point Size	"A" Dim.	Apex* No.
6716	T10	.107"	TX10-1
6717	T15	.128"	TX15-1
6718	T20	.151"	TX20-1
6719	T25	.173"	TX25-1
6720	T27	.195"	TX27-1
6720A	T30	.216"	TX30-1
6721	T40	.260"	TX40-1

## TORX DRIVER SIZE GUIDE

*Torx point size fits these fasteners*

TORX POINT SIZE	FOR USE WITH THESE TORX SCREW SIZES					
	Pan Hd.	Flat Hd.	100° Flat Hd.	Button Hd.	Socket Hd.	Set Screw
T10	6	6	6	5,6	4,5	-
T15	8	8	8	8	6	-
T20	10	10	10	-	-	1/4
T25	12	12	-	10	8	-
T30	1/4	-	1/4	-	1/4	3/8
T40	5/16	5/16, 3/8	5/16	5/16	-	7/16
T45	3/8	-	3/8	3/8	5/16	1/2
T50	7/16	7/16, 1/2	-	-	3/8	9/16



# Insert Bits (cont'd)

Heat treated tool steel. For use with magnetic bit holder (6767A) in drill chuck, cordless screwdrivers, or square drive magnetic hex bit holders.

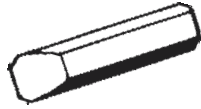

**SLOTTED**  
1/4" HEX SHANK, 1" LONG  
Pkg: 10 each

Part No.	Screw Size*	Blade Width	Blade Thickness
6732	4F-5R	.156"	.032"
6734	8F-10R	.250"	.042"
6735	10F-12R	.281"	.046"
6736	12F-14R	.281"	.050"
6737	14F-16R	.281"	.055"

## HEAVY DUTY SLOTTED\*\*

5/16" HEX SHANK, 1-1/2" LONG

Note: This item is not heat-treated. Pkg - 10 each

6789	8F-10R	.250"	.042"
6790	12F-14R	.313"	.050"

\*F - flat head; R - round head \*\*Do not use with Impact Drivers.

## SQUARE RECESS BITS

1/4" HEX SHANK, 1" LONG

Pkg: 10 each

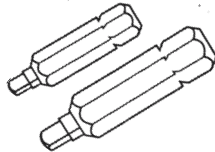

Part No.	Point Size	Screw Sizes
6797	0	3, 4
6798	1	5, 6, 7
6799	2	8, 10
6800	3	12, 1/4

## HEX BITS

1/4" HEX SHANK, 1-1/4" LONG

For Socket Screws. Pkg: 10 each



Part No.	BIT SIZE	SCREW SIZE	
		Cap	Set
6791	3/32	4-5	10
6792	1/8	-	1/4
6793	5/32	10	5/16
6794	3/16	1/4	3/8
6795	7/32	-	7/16
6796	1/4	5/16	1/2

# Magnetic Power Nutsetters

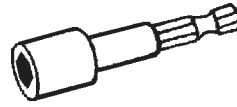

For Hex Head Self-Drilling and Tapping Screws. Magnetic to hold screw while positioning. Made of shock resistant tool steel and heat-treated for maximum strength and hardness.

## 2-9/16" LONG • 1/4" HEX SHANK

Hex Size	Part No.	Pkg Qty
1/4	6771	10
5/16	6772	10
3/8	6773	10
7/16"	6774	10



## 6" EXTRA-LONG • 1/4" HEX SHANK

Hex Size	Part No.	Pkg Qty
1/4	6775	10
5/16	6776	10
3/8	6777	10

# Magnetic Insert Bit Holder

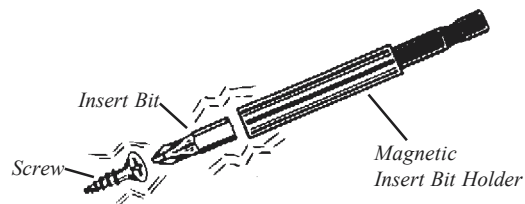

For use with any style 1/4" hex insert bit. Bits snap securely into holder to hold screw while positioning. Made from stainless steel. Pkg: 10 each

Part No.	Hex Opening	Hex Shank	O.A. Length
6767A	1/4"	1/4"	3"

Not for use with Power Shank Bits. Available in Female Square Drive for use with Ratcheting Tools.

# Ball End L-Wrenches



- Ball end provides convenience of off-axis rotation.
- Long-arm - provides leverage to attain full torque.
- Made of heat-treated 8650 alloy steel.

Part No.	Hex Size	Length	Pkg Qty
<b>INCH SIZES</b>			
29-330	.050	2.80"	10
29-331	1/16	3.00"	10
29-332	5/64	3.20"	10
29-333	3/32	3.40"	10
29-334	7/64	3.60"	10
29-335	1/8	3.80"	10
29-336	9/64	3.90"	10
29-337	5/32	4.10"	10
29-338	3/16	4.50"	10
29-339	7/32	4.90"	10
29-340	1/4	5.20"	10
29-341	5/16	6.00"	10
29-342	3/8	6.80"	10
29-343	7/16	7.50"	2
29-344	1/2	8.30"	2
29-345	9/16	9.00"	2
29-346	5/8	9.80"	2
29-347	3/4	11.30"	1
<b>METRIC SIZES</b>			
29-348	1.5mm	3.00"	10
29-349	2mm	3.20"	10
29-350	2.5mm	3.50"	10
29-351	3mm	3.90"	10
29-352	4mm	4.30"	10
29-353	5mm	5.00"	10
29-354	6mm	5.90"	10
29-355	8mm	6.70"	10
29-356	10mm	7.40"	10

# Ball End L-Wrench Sets

- Ball end provides convenience of off-axis rotation.
- Features handy tool holder
- Each wrench slips into its own size-marked slot and locks securely in place.
- Long-arm - provides leverage to attain full torque.
- Compact - fits in your pocket.
- Made of heat-treated 8650 alloy steel.

*Lifetime Guarantee Against Breakage!*

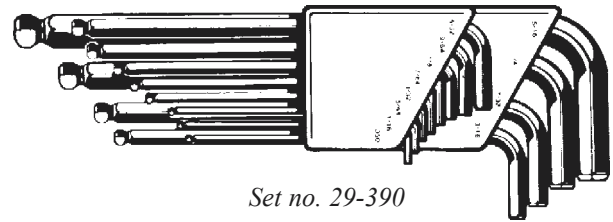

## INCH SETS

**12 PC. SET** Sizes .050, 1/16, 5/64, 3/32, 7/64, 1/8, 9/64, 5/32, 3/16, 7/32, 1/4 and 5/16. **Part No. 29-390**

**7 PC. SET** Sizes 5/64, 3/32, 7/64, 1/8, 9/64, 5/32 and 3/16. **Part No. 29-391**

## METRIC SETS

**6 PC. SET** Sizes 1.5, 2, 2.5, 3, 4 and 5 mm. **Part No. 29-392**

**9 PC. SET** Sizes 1.5, 2, 2.5, 3, 4, 5, 6, 8 and 10 mm. **Part No. 29-393**

## Need a Key Wrench Assortment?

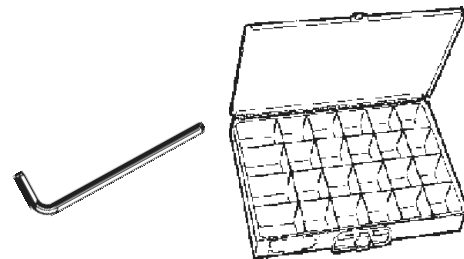

**LET MPI BUILD ONE  
JUST FOR  
YOU!**

# Hex Key Wrenches



Part No.	Hex Size	Length	Pkg Qty
----------	----------	--------	---------

## SHORT ARM HEX KEYS

6821	.028	1.30"	10
6822	.035	1.30"	10
6823	.050	1.70"	10
6824	1/16	1.70"	10
6825	5/64	2.00"	10
6826	3/32	2.10"	10
6827	7/64	2.20"	10
6828	1/8	2.30"	10
6829	9/64	2.50"	10
6830	5/32	2.60"	10
6831	3/16	2.70"	10
6832	7/32	3.10"	10
6833	1/4	3.30"	10
6834	5/16	3.75"	10
6835	3/8	4.25"	10
6836	7/16	4.75"	2
6837	1/2	5.25"	2
7015	9/16	5.75"	2
7016	5/8	6.25"	2
7017	3/4	7.30"	1
7018	7/8	8.30"	1
7019	1"	9.30"	1

## LONG ARM HEX KEYS

6838	1/16	3.10"	10
6839	5/64	3.30"	10
6840	3/32	3.35"	10
6841	7/64	3.65"	10
6842	1/8	3.85"	10
6843	9/64	4.00"	10
6844	5/32	4.20"	10
6845	3/16	4.60"	10
6846	7/32	5.00"	10
6847	1/4	5.30"	10
6848	5/16	6.00"	10
6849	3/8	6.75"	10
6850	7/16	7.50"	2
6851	1/2	8.25"	2
7020	9/16	9.00"	2
7021	5/8	9.75"	2
7022	3/4	11.30"	1
7023	7/8	12.80"	1
7024	1"	14.30"	1

**See a complete list of 'Metric' Key Wrenches on page 118.**

# Chamfered L-Wrench Sets

- Chamfered ends - clearance between the wrench and screw is usually less than .001" per side for faster socket entry.
- Features handy tool holder
- Each wrench slips into its own size-marked slot and locks securely in place.
- Long-arm - provides leverage to attain full torque.
- Compact - fits in your pocket.
- Made of heat-treated 8650 alloy steel.

*Lifetime guarantee against breakage!*

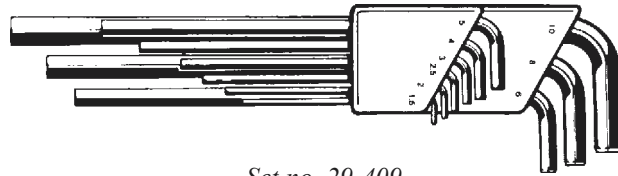

Set no. 29-409

## INCH SETS

**12 PC. SET** Sizes .050, 1/16, 5/64, 3/32, 7/64, 1/8, 9/64, 5/32, 3/16, 7/32, 1/4 and 5/16. **Part No. 29-409**

**7 PC. SET** Sizes 5/64, 3/32, 7/64, 1/8, 9/64, 5/32 and 3/16. **Part No. 29-410**

## METRIC SETS

**6 PC. SET** Sizes 1.5, 2, 2.5, 3, 4 and 5 mm. **Part No. 29-411**

**9 PC. SET** Sizes 1.5, 2, 2.5, 3, 4, 5, 6, 8 and 10 mm. **Part No. 29-412**

*"Genius is only a greater aptitude for patience."*

- George Villiers,  
Second Duke of Birmingham



# Vinyl Grip T-Handle Hex Wrench Sets

- Cushion grip for user comfort.
- Size marked for easy identification.
- Made of heat-treated 8650 alloy steel.
- Handy storage pouch

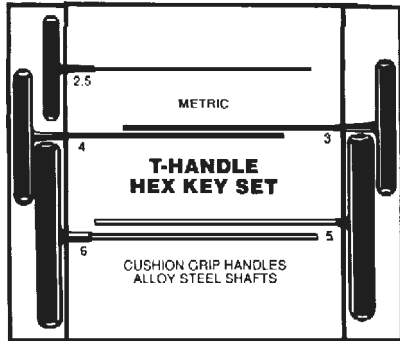

## REGULAR HEX END

Part No. 29-394 / INCH SIZES  
Includes 8 Tools  
Sizes: 3/32, 7/64, 1/8, 9/64, 5/32, 3/16, 7/32, 1/4

Part No. 29-395 / METRIC SIZES  
Includes 5 Tools  
Sizes: 2.5, 3, 4, 5, 6 mm

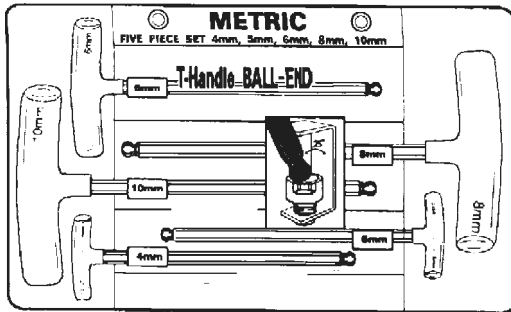

## BALL END STYLE

Part No. 29-396 / INCH SIZES  
Includes 6 Tools  
Sizes: 5/32, 3/16, 7/32, 1/4, 5/16, 3/8

Part No. 29-397 / METRIC SIZES  
Includes 5 Tools  
Sizes: 4, 5, 6, 8, 10 mm

# Vinyl Grip T-Handle Hex Wrenches

Plastic dipped cushion grip handles.



Choose from Ball End or Straight End.

## INCH SIZES

Ball End (Length)	Straight End (Length)	Hex Size	Pkg Qty
.....	29-363(6")	3/32	5
.....	29-364(6")	7/64	5
.....	29-365(6")	1/8	5
.....	29-366(6")	9/64	5
29-357(8.5")	29-367(6")	5/32	5
29-358(9.2")	29-368(6")	3/16	5
29-359(9.6")	29-369(6")	7/32	5
29-360(10.1")	29-370(6")	1/4	5
29-361(10.5")	29-371(6")	5/16	5
29-362(10.8")	29-372(6")	3/8	5

## METRIC SIZES

Ball End (Length)	Straight End (Length)	Hex Size	Pkg Qty
.....	29-378(4")	2.5mm	5
.....	29-379(4.3")	3mm	5
29-373(7.8")	29-380(6")	4mm	5
29-374(8.9")	29-381(6")	5mm	5
29-375(9.5")	29-382(6")	6mm	5
29-376(10.2")	29-383(6")	8mm	2
29-377(11")	29-384(6")	10mm	2



# T-Handle Hex Key Wrenches

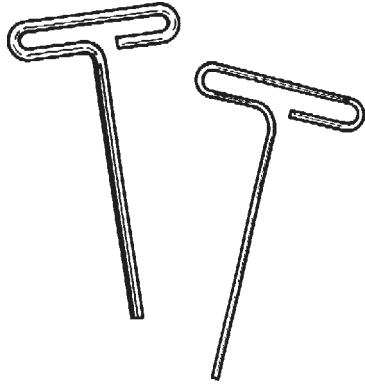

Hex size stamped on handle. Balanced loop design for maximum leverage. 8650 alloy steel. Pkg: 1 each.

Part No. 6" ARM	Part No. 9" ARM	Hex Size
6852 .....	6862 .....	3/32
6853 .....	6863 .....	7/64
6854 .....	6864 .....	1/8
6855 .....	6865 .....	9/64
6856 .....	6866 .....	5/32
6857 .....	6867 .....	3/16
6858 .....	6868 .....	7/32
6859 .....	6869 .....	1/4
6860 .....	6870 .....	5/16
6861 .....	6871 .....	3/8

# T-Handle Hex Key Wrench Sets

With Metal Stand

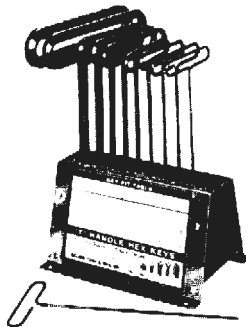

Part No.	Arm Length	No. Pieces	Size Range
6818 .....	6"	10 .....	3/16" - 3/8"
6819 .....	9"	10 .....	3/16" - 3/8"

# Fold-Up Hex Key Tools

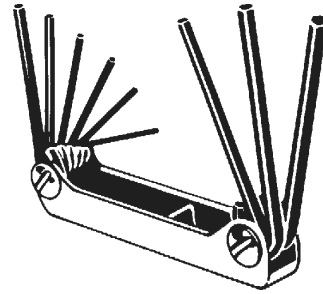

Rugged keys fold up into a convenient case like a pocket knife. Case doubles as a handle. Made from 8650 alloy steel. Black oxide finish. Pkg: 1 each.

Part No.	No. Keys	Size Range
6814 .....	8 .....	.050 - 5/32"
6815 .....	9 .....	5/64 - 1/4"
6813 .....	5 .....	3/16 - 3/8"
6816 .....	7 .....	1.5 - 6 mm
6817 .....	6 .....	4 - 10 mm

# Hex Key Sets

Short Arm

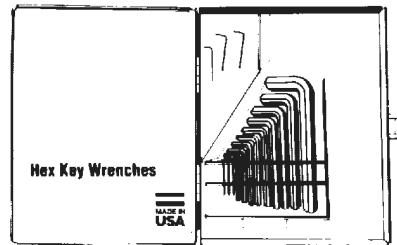
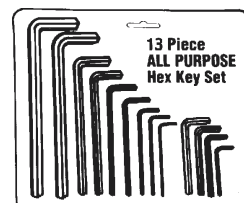

Made from heat treated 8650 alloy steel.  
Black oxide finish.

Part No.	Holder	No. Pieces	Size Range
6873 .....	Vinyl pouch .....	13 .....	.050" - 3/8"
6876 .....	Metal index .....	15 .....	.028" - 3/8"

# Utility Knives and Scrapers

## Safety Nose Retractable



Our biggest seller by far, this hefty, rugged tool is built to last a lifetime! Features the "SafetyNose"—a secure top and bottom nose overlap that will not split or separate. Ergonomic design fits the hand for a more comfortable grip. All metal construction. 3 blades included. Blade storage in handle. Color: Hi-visible orange. Made in U.S.A. Pkg: 1 each. **Part No. 21-300**

*Replacement blades: 10-532 bulk, 10-531 dispenser.*

## **new Stanley Swivel-Lock®**

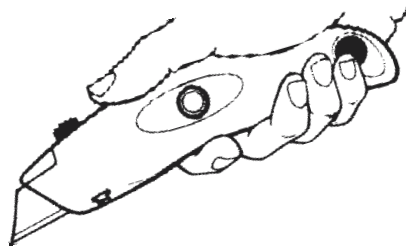

SWIVEL-OPEN HANDLE FOR QUICK BLADE CHANGES. ERGONOMIC DESIGN REDUCES SLIPPAGE. SAFETY NOSE FEATURE!

Push-button and "swivel" the handle open for quick blade change-overs. Ergonomic design fits the hand for a more comfortable grip. Safety nose features secure top and bottom nose overlap that will not split or separate. All metal die-cast construction. 3 blades included. Blade storage in handle. Color: Hi-visible yellow. Stanley model no. 10-989. Pkg: 1 each. **Part No. 10-742**

*Replacement blades: 10-619 dispenser*

## Front Loading

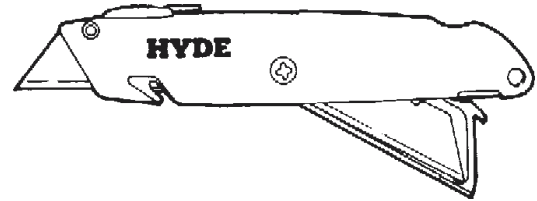

Automatic blade changing without opening the knife. String cutting without exposing blade. 3 blades included. Blade storage in handle. Color: Silver. Hyde model no. 42020. Made in U.S.A. Pkg: 1 each. **Part No. 10-527**

*Replacement blades: 10-532 bulk, 10-531 dispenser*

## Side Push Button

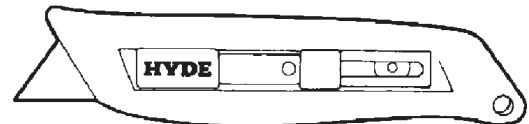

Side retractor assures stable blade position. Push retractor button to release. Slides in 2 blade positions. Die cast metal construction. 1 heavy duty blade included. Color: Silver. Hyde model no. 42000. Made in U.S.A. Pkg: 1 each. **Part No. 10-526**

*Replacement blades: 10-532 bulk, 10-531 dispenser*

## Razor Blade Scrapers

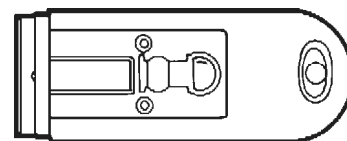

Removes paint and stickers from window glass. Retractable blade. Safe locking push button control. Includes one single edge razor blade. Polished metal construction. Hyde model no. 13000. Made in U.S.A. Pkg: 1 each. **Part No. 10-521**

*Replacement blades: 10-522 bulk*



# Single Edge Razor Blades



Use in razor blade scrapers, razor knives, wallcovering knives and vinyl knives. Industrial quality steel. Oiled to prevent rusting. Individually wrapped for safe handling. Made in U.S.A

Part No.	Description	Pkg Qty
10-522 ..	Single Edge Blades, 100 per Box .....	1

# Bulk Knife Blades

Handy bulk box of 100 heavy duty industrial quality blades. Dispenses 5 blades at a time (20 packs of 5 blades). Fits most utility knives. Thickness: .025". Made in U.S.A.



(Actual size)

Part No.	Description	Pkg Qty
10-532 .....	Bulk knife blades, 100 per box .....	1

*Fits our part numbers 10-526, 10-527, 21-300. Fits Hyde models: 42000, 42020, 42023, 42050, 42060, 42065, 42066, 42070, 42080, 42085, 42090, 13200 (scraper). Fits Stanley models 10-099, 10-199, 10-299, 28-499.*

VISIT OUR WEBSITE  
**mpi-online.com**  
FAX ANYTIME!  
**219-696-6413**

# Knife Blades with Dispenser

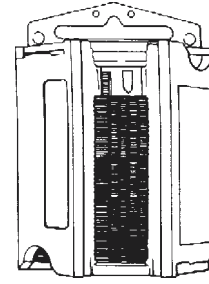

Handy dispenser contains 100 utility knife blades. Designed to be wall hung or fits easily into a tool box. Dispenses one at a time for safety and convenience. Choose from 3 blade styles.

Part No.	Brand	Blade Thickness	Pkg
----------	-------	-----------------	-----

10-531 ..... Hyde ..... .025" ..... 1  
*Fits our part numbers 10-526, 10-527, 21-300. Fits Hyde models: 42000, 42020, 42023, 42050, 42060, 42065, 42066, 42070, 42080, 42085, 42090, 13200 . Fits Stanley models 10-099, 10-199, 10-299, 28-499.*

10-618 ..... Stanley ..... .017" ..... 1  
*Fits Stanley models: 10-199, 10-299, 10-519, 10-599, 10-901.*

10-619 ..... Stanley ..... .025" ..... 1  
*Fits our part numbers 10-742, Fits Stanley models: 10-079, 10-099, 10-199, 10-299, 10-399, 10-499, 10-519, 10-599, 10-989, 28-593.*

(Actual sizes below)



10-531



10-618



10-619

# Putty Knives & Scrapers

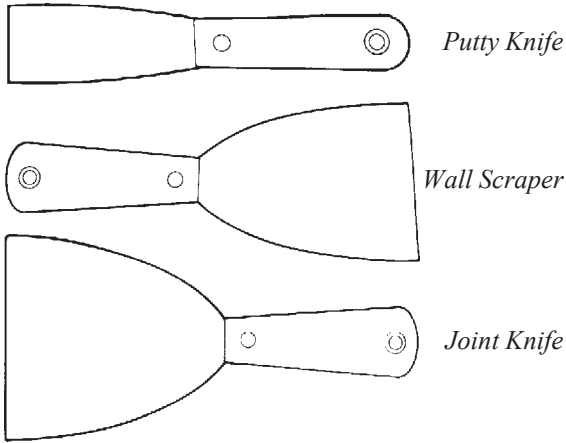

High carbon steel blades. Durable handles resistant to common paint thinners. Made in U.S.A.

Part No.	Style	Blade Width	Blade Type	O.A. Length
10-499	Putty Knife	1-1/4"	Stiff	7-1/4"
10-502	Putty Knife	1-1/2"	Stiff	7-3/4"
10-505	Putty Knife	2"	Stiff	8"
10-508	Wall Scraper	3"	Stiff	8"
10-519*	Burn-off, Bent	3"	Stiff	9"
10-510	Joint Knife	4"	Flexible	8"

\*Paint Scraper with 20° bend (not pictured).

# Mechanic's Wire

(Baling Wire)

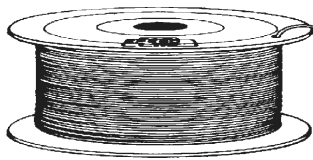

Multipurpose utility wire for wrapping and tying. Made from annealed steel wire. Plain black finish. Furnished in 5 lb. spools.

Part No.	Gauge	Wire Dia.	Pkg Qty
1831	20	.0348"	1 RL
1832	18	.0470"	1 RL
1833	16	.0630"	1 RL

# Perforated Strapping

(Hanger Iron)

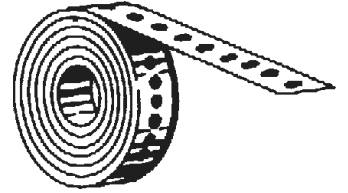

A malleable steel strapping used for hanging fixtures, pipes, drains, conduit, air ducts, mufflers and more. Comes with 1/4" holes on 1/2" centers. Made from galvanized steel.

Part No.	Width	Length	Thick-ness	Pkg Qty
1834	3/4"	10ft.	.035"	10

# General Purpose Masking Tape



Excellent for general painting and masking. Not recommended for use on automotive finishes.

Part No.	Size	Pkg Qty
17-005	1/2" x 60 yards	1 RL
17-005C	CASE of 72 rolls	1 CS
17-006	3/4" x 60 yards	1 RL
17-006C	CASE of 48 rolls	1 CS
17-007	1" x 60 yards	1 RL
17-007C	CASE of 36 rolls	1 CS
17-009	2" x 60 yards	1 RL
17-009C	CASE of 24 rolls	1 CS

When American Airlines wanted to advertise its new leather first class seats in the Mexican market, it translate its "Fly In Leather" campaign literally, which meant "Fly Naked" (vuela en cuero) in Spanish!



# Cloth Duct Tape

*All Purpose Grade*



High strength with exceptional adhesive qualities. Apply to sheet metal and fiber duct. Stops air leakage and prevents dust, moisture, and odors from entering duct. Ideal for attaching duct insulations. Color: Silver.

Part No.	Size	Pkg Qty
17-004 .....	2" x 60 yards .....	1 RL
17-004C .....	CASE of 24 rolls .....	1 CS

# Clear Carton Sealing Tape & Dispenser

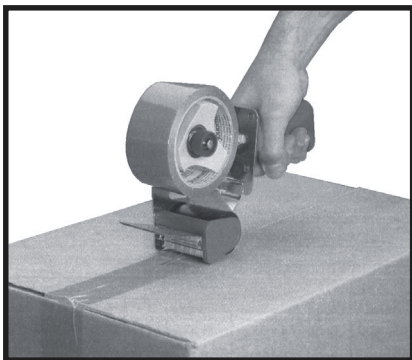

Clear, pressure sensitive polyethylene packaging tape adheres to all types of cartons. Highly impact resistant. Quick and easy dispenser (sold separately) is steel and plastic construction. Designed for all 2" wide packaging tapes.

Part No.	Description	Pkg Qty
17-101 .....	Carton Sealing Tape, 2" x 165' .....	36 RL
17-102 .....	Tape Dispenser .....	1 EA

# Strapping Tape

*Fiberglass Filament*



Tough, durable, and tear-proof. Excellent for carton sealing. High tensile strength for heavy cartons, palletizing loads or strapping steel rods.

Part No.	Size	Pkg Qty
17-010 .....	1/2" x 60 yards .....	72 RL
17-011 .....	3/4" x 60 yards .....	48 RL
17-012 .....	1" x 60 yards .....	36 RL

# Teflon Pipe Tape

*Dope Tape*

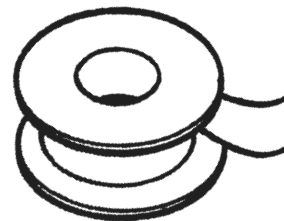

Seals all threaded connections under the most difficult service conditions. Made of pure white teflon. Use on any surface. Withstands chemicals and solvents. Non-toxic. Safe for water lines.

*Each roll enclosed in plastic dust-proof case.*

Part No.	Size	Pkg Qty
17-081 .....	1/4" x 520" .....	50 RL
17-082 .....	1/2" x 520" .....	50 RL
17-013 .....	1/2" x 1296" .....	50 RL
17-083 .....	3/4" x 520" .....	50 RL

# Electrical Tape

## 3M™ Scotch™ Super 33+ Vinyl Electrical Tape



Super 33+ is a stickier, stretchier, highly conformable premium grade 7-mil thick tape that applies well at temperatures as low as -18°C/0°F and has an operating temperature range to 105°C/220°F. Flame retardant, hot and cold weather resistant. Resists UV rays, moisture, alkalis, acids and corrosion. Use as a primary insulation for wire cable splices up to 600V and for fixture and wire splices up to 1 kV. Meets ASTM, UL, HHI and CSA requirements.

Part No.	Size	Pkg
17-000 .....	3/4" x 66 ft. roll .....	10 RL
17-000C .....	CASE of 100 rolls .....	1 CS

## 3M™ Scotch™ Super 88 Vinyl Electrical Tape



A heavy duty, 8.5-mil thick, flame retardant, weather resistant tape with superior cold weather handling features. Extra thickness provides added electrical properties, quicker insulation buildup and abrasion resistance. Remains conformable on cold days—even at -18°C/0°F and has an operating temperature range to 105°C/220°F. Resistant to UV rays, moisture, alkalis, acids and corrosion. Meets ASTM, UL, CSA and MIL specifications.

Part No.	Size	Pkg
17-008 .....	3/4" X 66 ft. roll .....	10 RL
17-008C .....	CASE of 100 rolls .....	1 CS

## 3M™ Temflex™ 1700 Vinyl Electrical Tape



Temflex 1700 is 3M's economical, yet durable line of 7-mil thick electrical tape. Performs well in a variety of indoor and outdoor installations. Flame retardant, UL listed and CSA certified for 80°C/176°F. Made in USA.

Part No.	Size	Pkg
17-019 .....	3/4" x 60 ft. roll .....	10 RL
17-019C .....	CASE of 100 rolls .....	1 CS

## 3M™ Scotch™ 130C Linerless Rubber Splicing Tape



A highly conformable, high-voltage insulating tape formulated to provide excellent thermal dissipation of splice heat. Self-vulcanizes to a watertight bond. Rated for continuous operating service to 90°C and for short term overload service to 130°C. Insulates electrical connections thru 69kV. Stretch and wrap rubber tape under tension with a 50% overlap. Linerless feature provides faster, hassle-free installation. Add a layer of 3M electrical tape or friction tape to protect from abrasion and UV rays. Meets ASTM and HHI requirements.

Part No.	Size	Pkg
17-020 .....	3/4" x 30 ft.roll .....	10 RL

## 3M™ Temflex™ 1755 Friction Tape



Temflex 1755 is a 15 mil thick, coated cloth tape used in electrical and mechanical applications. Made from high quality cotton fabric, coated with an electrical grade adhesive. Provides extra protection against friction and wear due to movement and vibration. Commonly used to protect rubber splicing tapes. Meets ASTM standards.

Part No.	Size	Pkg
17-020B .....	3/4" x 60 ft roll .....	10 RL



# Electrical Tape

## 3M™ Scotch™ 27 Glass Cloth Electrical Tape



A 7-mil thick tape with thermosetting, pressure sensitive adhesive which performs at class B temperatures (130°C/266°F). 27 provides heat-stable insulation for hot-spot applications, such as furnace and oven controls, motor leads and switches. UL recognized component listing for 150°C. CSA accepted component listing for 130°C. Made in U.S.A.

Part No.	Size	Pkg
17-119	1/2" x 66 ft roll	10 RL

## 3M™ Scotch™ Electrical Moisture Sealant

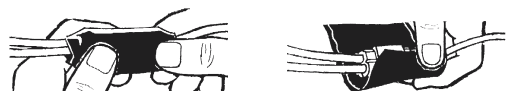

A tough, self-fusing, rubber based, insulating compound laminated to an all-weather grade vinyl (PVC) backing. Molds easily around difficult shapes and will insulate, moisture seal, and pad all connections up to 600V. Protects against elements and abrasion. Replaces common electrical tape for all season, all weather protection. 60 applications per roll.

Part No.	Size	Pkg Qty
17-014	2 1/2" x 10 ft.	10 RL

## GAMPAK® Color-Coded Electrical Tape

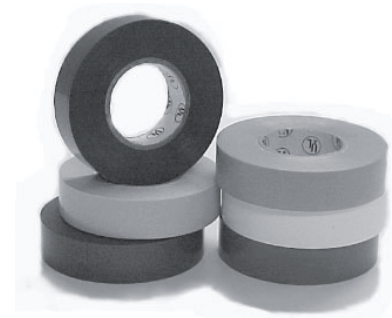

Pressure sensitive vinyl electrical tape used where color-coded wires are unavailable. Cold and weather resistant. Suitable for use at not more than 600 Volts as primary insulation. Flame retardant. UL recognized 119K at 80°C (176°F). CSA accepted. Roll size: 3/4" x 66 ft. Imported. (Not a 3M product)

Part No.	Color	Pkg
17-078	Red	10 RL
17-079	White	10 RL
17-080	Green	10 RL
17-085	Yellow	10 RL
17-087	Blue	10 RL
17-088	Orange	10 RL

17-096 ... Color-coded Electrical Tape Asst. .... 1 Kit  
Contains one of each color shown (bagged).

## Liquid Electrical Tape



A dielectric coating that seals out moisture and prevents corrosion. Insulates, protects, will not crack, peel or harden. Remains flexible under extreme conditions. Acid and salt resistant. Stops terminal screws from vibrating loose. Applications: Terminal connections, damaged wire insulation and battery terminals on boats, trailers, autos, pumps, timers, pool filters and more. UL listed 746A Color: black. Made in U.S.A.

Part No.	Size	Pkg Qty
30-1002	4 oz. brush-can	12



# 3M™ Safety Walk™

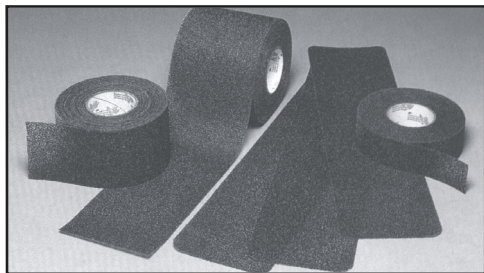

## **new** 610 General Purpose Treads

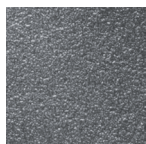

The most popular and economical of 3M's anti-slip tread line. Use *General Purpose Treads* for dry, wet and oily situations. This easy-to-apply tape has a mineral coated, slip-resistant and highly durable surface. Low-profile design reduces trip hazards. Pressure sensitive adhesive backing stands up to traffic immediately after installation. Applications: entry-ways, stairs, ramps, aisles, walkways, loading docks, locker rooms<sup>2</sup>, around machinery, steps and walk areas on industrial equipment and vehicles. Can be cut to fit special size requirements. *Note: For use on smooth flat surfaces only<sup>1</sup>. Not for use on surfaces subjected to hydrocarbon solvents and fuels.* Color is black.

Part No.	Size	Pkg
17-053	1" x 60'	4 rolls
17-054	2" x 60'	2 rolls
17-055	4" x 60'	1 roll
17-056	6" x 60'	1 roll
17-057	12" x 60'	1 roll

Sizes and colors not shown may be available on special request, subject to minimum packaging.

*Job-specific 3M™ Safety Walk™ products available...*

<sup>1</sup>*Conformable Treads* for irregular surfaces— Perfect for diamond grade safety plates, ladders, steps, etc.

<sup>2</sup>*Easy Clean Treads*. Will not shred mops or other cleaning tools — Preferred in locker rooms, showers, saunas, pool areas, etc..

*Medium Resilient Treads*. A nonmineral surface suitable for bare feet areas—Used on boats, boat docks, interior stair wells, entryways and lobbies.

*Slip-Resistant Matting*. These popular nonstick floor mats are available in 3 and 4 foot widths and lengths through 20 feet. Can be moved and repositioned at any time.— Found in processing plants, walk-in coolers-freezers, restaurants/kitchens, machine shops and work areas nationwide.

Special orders subject to factory minimum packaging.

See also "Big Foot Anti-Slip Coatings" on page 381.

## **new** Painting Accessories



### 9" Paint Roller Covers

Economical and disposable. 3/8" nap thickness for use on smooth or semi-smooth walls. 9" in length. 100% polyester with phenolic core. Use with latex paints only. Pkg: 24 each (shipped in twin packs) **Part No. 17-073**

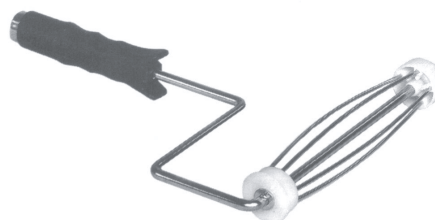

### 9" Paint Roller Frame

For standard 9" rollers covers. Durable 5 wire cage. Pkg: 10 each. **Part No. 17-074**



### Galvanized Paint Tray

For 7" and 9" rollers. Standard galvanized steel 2 quart capacity. Rust retardant. Pkg: 10 each. **Part No. 17-075**

### Plastic Tray Liner

(Not shown) Black plastic liner makes cleanups easy. Fits in paint tray above. Pkg: 10 each. **Part No. 17-076**



### Painter's Mitt

Can be used with all types of paint. Lint-free synthetic glove with protective plastic liner. Use on fences, railings, pipes and hard-to-reach areas. Pkg: 10 each. **Part No. 17-077**



# 3M Scotch-Code™ Wire Marker Tape Dispenser



**Dispenser only.** Provides fast, convenient marking of wire and cable. Ten refillable compartments let you choose any number combination needed. Holds ten rolls. **Part No. 10-678**

*Tape sold separately (see below).*

# 3M Scotch-Code™ Wire Marker Tape

Durable white plastic tape with black numbers for use with 3M's Scotch-Code™ dispenser shown above.

**Roll size: .215 in. x 8 ft.**

Part No.	Description	Pkg Qty
<b>ASSORTED NUMBERS - 1 each</b>		
10-679	0 thru 9 (total 10 rolls)	1 Pkg
<b>INDIVIDUAL NUMBERS</b>		
10-680	0	10 Rolls
10-681	1	10 Rolls
10-682	2	10 Rolls
10-683	3	10 Rolls
10-684	4	10 Rolls
10-685	5	10 Rolls
10-686	6	10 Rolls
10-687	7	10 Rolls
10-688	8	10 Rolls
10-689	9	10 Rolls

A man who views the world at 50 the same as he did at 20 has wasted 30 years of his life.

-Muhammed Ali

# Gasket Material

*(Sheet Packing)*



## Red Rubber Gasket Material

Use for hot and cold water, saturated steam, and air applications. Remains soft and pliable. Withstands temperatures to +180° F. Durometer hardness; 75-85. Roll size: 36" x 36".

Part No.	Thickness	Pkg.
15-011	1/16	1 RL
15-012	3/32	1 RL
15-013	1/8	1 RL
15-014	3/16	1 RL

## Cork Gasket Material

Flexible, firm gasketing resistant to most oils, petroleum products and chemicals. Makes excellent vibration dampening and cushioning material. Withstands temperatures to +200° F. Roll size: 36" x 36".

Part No.	Thickness	Pkg.
15-022	1/16	1 RL
15-023	3/32	1 RL
15-024	1/8	1 RL

## Fiber (Paper) Gasket Material

Composed of vegetable fibers, fiber gasketing seals against fluids like gasoline, oil, inert gases, grease, tar, compressed air, hot and cold water. Pliable and compressible. Withstands temperatures to +250° F. Roll size: 36" x 36".

Part No.	Thickness	Pkg.
15-025	1/64	1 RL
15-026	1/32	1 RL
15-027	1/16	1 RL
15-028	3/32	1 RL
15-029	1/8	1 RL

*Also available in neoprene and compressed nonasbestos gasket material.*

# Gasket Material Assortment

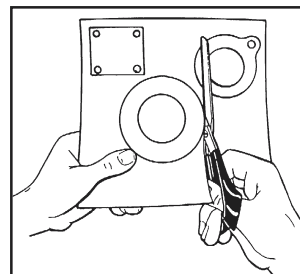

12 piece assortment includes 3/32" black rubber, 3/32" cork and 1/16" paper gasket material in 6 inch square sheets (boxed). **Part No. 31-710**

# Steel Shim Stock



Precise thicknesses to handle almost any shimming application. Use individually or combine them for the size you need. Shim Stock can be bored, stamped, cut, milled, sheared, and drilled into any shape and size. Used in tool and die set up, machine assembly and repair - mounting motors and pumps, prototype work and pilot production runs. Roll size: 6"W x 100"L

Part No.	Thickness	Pkg
12-020	.003"	1 RL
12-022	.004"	1 RL
12-023	.005"	1 RL
12-024	.006"	1 RL
12-025	.007"	1 RL
12-028	.010"	1 RL
12-031	.015"	1 RL
12-034	.020"	1 RL
12-036	.025"	1 RL
12-037	.031"	1 RL

# Clear Plastic Covers

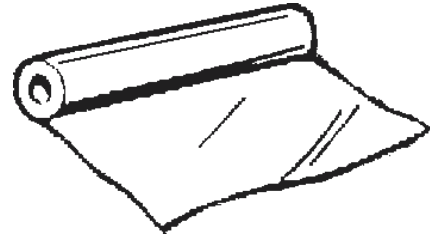

**INDUSTRIAL STRENGTH — 4 ML THICK**  
Protects against wind, dust, moisture and chemicals. Uses: drop cloth, equipment covers, construction enclosures, vapor barriers, window covering, leaky roofs, water tanks, pit liners, greenhouse walls, etc. Made in U.S.A.

Part No.	Width	Length	Thick-ness	Pkg Qty
17-130	10 ft.	25 ft.	4 ml.	1 RL
17-131	15 ft.	50 ft.	4 ml.	1 RL
17-132	20 ft.	100 ft.	4 ml.	1 RL

# Steel Shim Stock Assortment

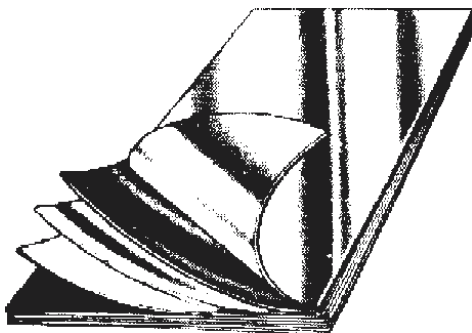

## 6" x 12" Flat Sheets

15 piece assortment contains: .001", .0015", .002", .003", .004", .005", .006", .007", .008", .010", .012", .015", .020", .025", .031". Made from cold rolled, full hard mild steel. Hardness: Rb80. **Part No. 12-056**

# Trash Can Liners



Thick, flexible plastic can liners come with handy dispenser box. Liners roll out for easy dispensing. Color: brown\*. Pkg: 1 Box

Part No.	Size	Thick-ness	No. Bags /Box	Type
17-125*	13 gal.	0.70 ml	90	Draw-string
17-126	26 gal.	1.25 ml	100	Twist-tie
17-127	30 gal.	1.50 ml	100	Twist-tie
17-128	33 gal.	1.50 ml	100	Twist-tie
17-134	55 gal.	.65 ml	200	Twist-tie
17-129	55 gal.	1.75 ml	100	Twist-tie

\* 17-125 kitchen bags are white in color



**!new** **C-Fold Towels & Dispenser**

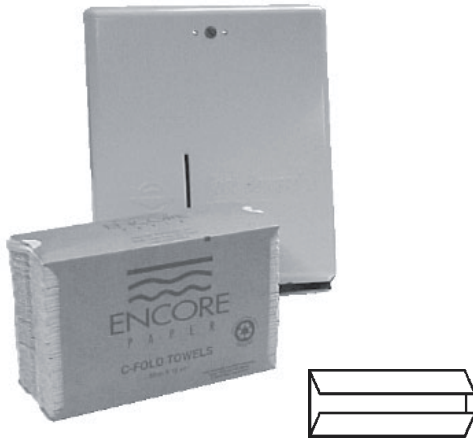

This highly absorbent flat sheet paper towel is perfect for restrooms and wash areas. Packaged in convenient 200 sheet sleeves (12 sleeves per case). Color: white. Made in U.S.A. *Sold only by the case.*

Part No.	Sheet Size	Sheets per case	Pkg Qty
17-070	10.25"x12.75"	2,400	1 Case
17-071	Metal Wall Dispenser (white) 1 Ea		

**Scott® Shop Towels**



*In convenient pop-up box or roll.*

Highly absorbent blue shop towels performs like a cloth, but at a fraction of the cost. One towel can be used again and again. Extra-heavy duty—strong enough to handle the toughest messes like grease and oil, solvents, hand cleaner and more. Excellent for hand polishing metals too! Color: blue. Made in U.S.A. *Sold by the roll or case lot.*

Part No.	Sheet Size	Square Ft.Pkg	Sheets per pkg	Pkg Qty
17-068	10.4"x11"	194	55	30 Rolls
17-069	10"x14"	43	200	1 Box

**Multi-Purpose Hand Cleaning Towels**

Removes dirt, resins, tar, oil, grease, wax, printers ink, paint, adhesives, rubber gasket cement and tile cement from hand, face, tools, countertops and work areas. Great for all non-porous surfaces around your shop, office or home. To aid in cleaning, the towels are made from a rough, yet non-scratching fabric that helps lift away heavy deposits of grime and dirt. Reduces trips to wash area. Towel size: 10" x 12".



Part Number	Cannister Size	Pkg Qty
30-1009	Large (130 count)	4 Ea
30-1007	Medium (70 count)	6 Ea
30-1008	Small (20 count)	12 Ea

**Teri® Reinforced Wipers**



A tough, 4-ply towel with nylon reinforcement for extra strength, even when wet. Convenient pop-up box keeps towels clean, fresh and uncontaminated. Color: white. Made in U.S.A. *Sold by the box or case lots.*

Part No.	Sheet Size	Sheets per box	Pkg Qty
17-072	10"x17"	150	6 Boxes

# **Rope Ratchet™**

## **Compact Ratchet Tie-Down System**

Tie-down loads and tarps. Secure aircraft and boats. Straighten wind-blown trees or hang game. Attach two hooks supplied and pull the loose end of rope tight. Rope Ratchet may be pulled as tightly as needed. Once pulled, it stays put. Release tension by taking up slack and pushing the convenient thumb release lever. 8 feet of solid braid rope included. Made in U.S.A.



Part No.	Load Limit	Description	Pkg Qty
10-745 .....	150 LBS .....	1/4" Rope (2-Pack) ..	1 Pkg
10-746 .....	150 LBS .....	1/4" Rope (6-Pack) ..	1 Pkg
10-747 .....	250 LBS .....	3/8" Rope (1-Pack) ..	1 Pkg
10-748 .....	250 LBS .....	3/8" Rope (6-Pack) ..	1 Pkg

# **Rubber Tarp Straps**



Prevents flapping tarps, increases tarp life. Special polymer resists the sun and bad weather. Shipped assembled. Made in the U.S.A.

**Pkg: 50 EACH**

Part Number	Rubber Length	Span Length
3163 .....	9" .....	15"-19"
3164 .....	15" .....	20"-29"
3165 .....	20" .....	30"-39"
3166 .....	31" .....	40"-49"
3167 .....	41" .....	50"-61"

*Caution: Failure can occur with any tarp strap. Proper safety precautions should be used whenever working around rubber straps.*

# **Plastic Tarps**



Fiber reinforced polyethylene cover with rope reinforced edges and rust resistant grommets. Shrinkproof, waterproof and washable.

Part No.	Size	Pkg
23-293 .....	6' x 8' .....	1
23-294 .....	8' x 10' .....	1
23-296 .....	10' x 20' .....	1
23-297 .....	12' x 16' .....	1
23-298 .....	16' x 20' .....	1
23-299 .....	18' x 24' .....	1

# **Tarp Rope & Hooks**

## **Rubber Tie-Down System**

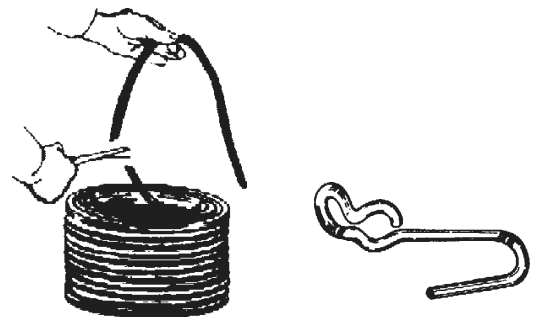

1. Custom cut the length you need with scissors or knife.
2. Add the eye hooks.



**Fast-Hitch**



**Permanent Installation**

Part No.	Description	Unit
3168 .....	7/16" x 150' Cord .....	1 RL
3169 .....	Double Eye Hooks .....	50 EA

# Hickory Hammer Handles

Flame tempered, American hickory. Hickory's long fibers and unique cellular structure allows this handle to absorb and dissipate impact shock before it reaches the user. Clear lacquer finish.  
Each handle includes one steel and one wooden wedge. All Pkg. Qty. - 1 each

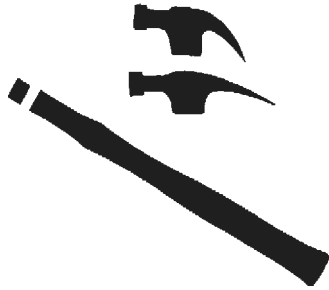

## NAIL/CLAW/CARPENTERS HAMMERS

Part No.	Length	Eye Size	Tool Size
21-468	12"	7/16 x 13/16	4 - 7 oz.
21-469	13"	1/2 x 15/16	13 oz.
21-470	14"	9/16 x 1-1/16	16-20 oz.



## HATCHETS - HALF/CLAW/BUILDERS/BROAD

Part No.	Length	Eye Size
21-476	14"	9/16 x 1-9/16



## MACHINIST/BALL PEIN HAMMERS

Part No.	Length	Eye Size	Tool Size
21-471	12"	7/16 x 3/4	8-12 oz.
21-472	14"	17/32 x 29/32	16-20 oz.
21-473	16"	19/32 x 1-1/16	24-28 oz.

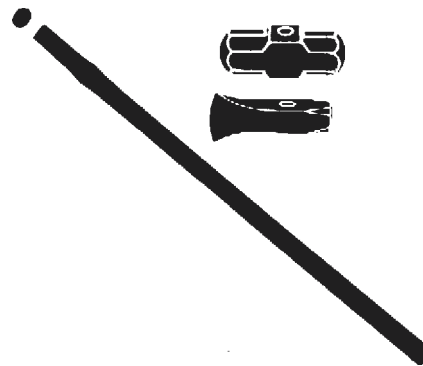

## SLEDGE/SPIKE MAUL/WOOD-CHOPPERS MAUL

Part No.	Length	Eye Size	Tool Size
21-477	36"	1 x 1-3/8	6-16 lbs.

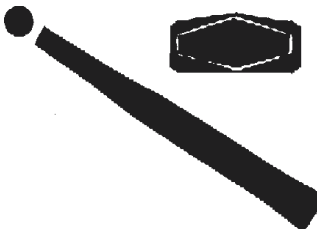

## BLACKSMITH/ENGINEERS/CROSSPEIN/DOUBLE FACED (OVAL EYE)

Part No.	Length	Eye Size	Tool Size
21-474	16"	3/4 x 1	2-1/2 - 4 lbs.
21-475	18"	1 x 1-1/4	6 - 8 lbs.

*Why does sour cream  
have an  
expiration date?*

# Lightweight Ratchet Tie Downs

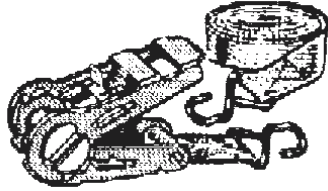

**1" WIDE WEBBING.** Overall length: 15 ft. Working load limit: 400 lbs. Breaking strength: 1,200 lbs. For small loads on utility trailers, automobiles and pickup trucks. Heavy duty ratcheting design with quick release mechanism. S-hooks are heat-treated and vinyl coated. Working load limit: 400 pounds. Breaking strength: 1,200 pounds. Pkg: 1 each. **Part No. 10-720B**

# Heavy Duty Ratchet Straps

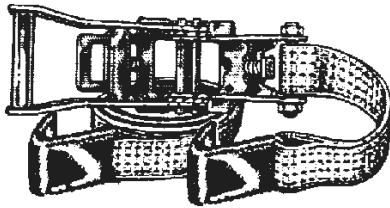

## 27 FT. STRAPS • FLAT HOOKS

Designed to handle most types of flatbed tie-down requirements. Extra long & wide handle. Meets CVSA guidelines. Made in U.S.A.

**2" WIDE WEBBING** Overall length: 27ft. Fixed end length: 18". Working load limit: 3,335 lbs. *D.O.T. requirement: 1 strap for every 3,335 lb. load.* Breaking strength: 10,000 lbs. Pkg: 1 each. **Part No. 10-713**



**3" WIDE WEBBING** Overall length: 27ft. Fixed end length: 18". Working load limit: 5,000 lbs. *D.O.T. requirement: 1 strap for every 5,000 lb. load.* Breaking strength: 15,000 lbs. Pkg: 1 each. **Part No. 10-712**

*Sizes and styles not shown may be available on special request, subject to minimum packaging.*

**WARNING! WEBBING MUST BE PROTECTED WHEN USED ON ROUGH OR SHARP OBJECTS. RATCHET STRAPS THAT ARE DAMAGED, CUT OR WORN SHOULD BE REPLACED IMMEDIATELY.**

# Master® Laminated Pad Locks

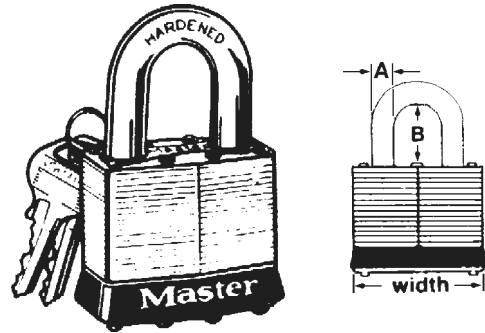

**MAXIMUM SECURITY STEEL PADLOCKS**  
Recommended for high security uses. Very resistant to physical abuse. Case hardened and chrome plated alloy steel shackle. Exclusive patented shackle design guards against shimming or rapping. Resilient bumper keeps padlock from marring or scratching. Cadmium plated body.

"Keyed-alike" locks sold only in packages of 6.

Part No.	Tumbler Keyed	Pkg Qty	SHACKLE		
			A	B	Width
<b>Gas Pumps, Lockers, Tool Boxes</b>					
10-604	Different	1	9/32	3/4	1-1/2
10-605	Alike	6	9/32	3/4	1-1/2
<b>Cabins, Sheds, Boat Houses</b>					
10-602	Different	1	5/16	15/16	1-3/4
10-603	Alike	6	5/16	15/16	1-3/4
<b>Vending Machines, Store Fronts</b>					
10-600	Different	1	7/16	1"	2"
10-601	Alike	6	7/16	1"	2"
<b>Truck Doors, Warehouses, Box Cars</b>					
10-598	Different	1	7/16	1"	2-1/2
10-599	Alike	6	7/16	1"	2-1/2

# Electric Heater

*(Milkhouse Heater)*

Quiet, fan-forced convection heat. Nichrome wire non-glow elements, automatic on/off thermostat with operation indicator light, dual heat rocker switch (750-1500w), overload thermal protector (circuit breaker), rugged steel cabinet, color is charcoal gray. UL approved, 2 wire cord with 2-prong connector, 120 volts, 60 hz AC, 1500 watts. Made in U.S.A.

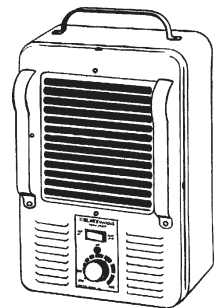

**Part No. 17-169**



It only takes 3 things to make your shop run smoothly...

# Assortments!

# Assortments!

# Assortments!

And **MPI** makes it easy for you!

**HUNDREDS OF ASSORTMENTS IN STOCK!** Ask your MPI representative to show you our Assortment Catalog with hundreds of special assortments to fit your needs. For details, call our office to request a fax of the actual lid chart showing illustrations and quantities. Look for our flyers showing the "Assortment of the Month", featuring new assortments and standard assortments at bargain prices.



**STANDARD ASSORTMENTS** We have popular assortments on the shelf and ready to ship. They include the most popular items and sizes used and a generous quantity of parts to get you started. Many standard assortments have space available for future expansion.

**CUSTOM ASSORTMENTS** We make custom assortments from scratch or by modifying our regular assortments.

**LABELS WITH ACTUAL SIZE ILLUSTRATIONS** Most assortments have actual size pictures to make choosing and sorting parts easy. All assortments have our part numbers clearly labeled to make ordering a breeze.

**DRAWER FRONT LABELS** Each assortment has a picture label on the front to help you easily locate what parts are in what bin.

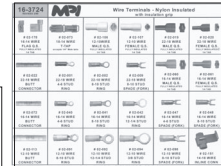

**STORAGE OPTIONS** Choose from several styles of bins and cabinets to suit your needs. The cost of storage equipment is always included in the assortment, so it's yours to keep! You never have to worry about anyone removing your bins because you switched vendors.

**PARTS BIN ASSORTMENTS** Our steel parts bins are the heaviest in the industry. It will take all the rough handling you can give it and still come back for more! No sharp edges to cut you. Clearly labeled and coated with a plastic spray to allow easy cleanup.

**MAINTENANCE KITS** Our handy Maintenance Kits make stocking a large variety of parts easy and inexpensive. Each kit is in a see-through styrene plastic compartmented box so you can see at a glance just what's inside. The lid is labeled for easy reordering.



**DRAWER ASSORTMENTS** Our most popular assortments come equipped with a steel drawer, featuring a lift-up lid that latches shut to keep out dirt and prevent spillage. The drawers fit easily in the handy steel slide rack (shown at right) and most competitive slide rack brands. Ask your sales representative how you can get a FREE 4-DRAWER SLIDE RACK to hold your new drawer assortments. The rust-proof, seamless heavy duty plastic insert has been on the market for years and will take the toughest abuse. Deep pockets hold a full box of small parts.

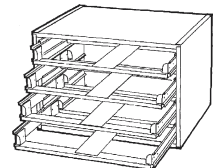

**BIN SERVICE** Your MPI representative can restock your parts room on a scheduled basis with just the right amount of product you need.

**LABEL SERVICE** Are your old bin labels dirty and torn? Give us a list and we'll make more for you..at no charge!



# Assortments



TYPE 1

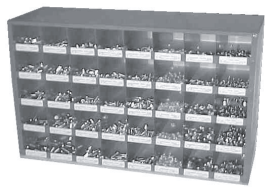

TYPE 2



TYPE 3



TYPE 4

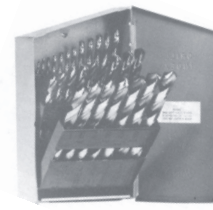

TYPE 5



## HEX HEAD CAP SCREWS

Part No.	Description	Bin Type	No. Sizes	Cabinet
72-100	GRADE 5 NC w/Nuts and Washers, 1/4-3/4 to 4"	1	72	98-72B
80-100	GRADE 5 NC - same as 72-100, except with two 40 hole bins.	2	72	2, 98-40B
72-100R	ASSORTMENT REFILL for 72-100, 80-100 (above)	-	72	-
72-102	GRADE 5 NC w/Nuts and Washers, 1/4-3/4 to 4"	1	72	98-72B
72-110	GRADE 5 NC w/Nuts and Washers, 1/4-3/4 to 6" - extra long lengths	1	72	98-72B
80-110	GRADE 5 NC - same as 72-110, except with two 40 hole bins.	2	72	2, 98-40B
72-110R	ASSORTMENT REFILL for 72-110 or 80-110 (above)	-	72	-
40-100	GRADE 5 NC w/Nuts and Washers, 1/4-1/2 to 3"	2	40	98-40B
40-100R	ASSORTMENT REFILL for 40-100 assortment (above)	-	40	-
16-0124	GRADE 5 NC w/Nuts, 1/4-1/2 to 3"	3	24	98-DL24
72-104	GRADE 8 NC w/Nuts and Washers, 1/4-3/4 to 4"	1	72	98-72B
80-104	GRADE 8 NC same as 72-104, except with two 40 hole bins.	2	72	2, 98-40B
40-102	GRADE 8 NC w/Nuts and Washers, 1/4-1/2 to 3"	2	40	98-40B
72-105	GRADE 8 NF w/Nuts, 1/4-3/4 to 6" - extra long lengths	1	72	98-72B
72-106	GRADE 8 NF w/Nuts and Washers, 1/4-3/4 to 4"	1	72	98-72B
40-103	GRADE 8 NF w/Nuts and Washers, 1/4-1/2 to 3"	2	40	98-40B
40-104	METRIC CLASS 8.8 COARSE M6-M12 dia. w/Nuts and Washers	2	32	98-40B
40-104R	ASSORTMENT REFILL for 40-104 (above)	-	32	-
16-2424	METRIC CLASS 8.8 COARSE M4-M7 dia. w/Nuts	3	24	98-DL24
16-2524	METRIC CLASS 8.8 COARSE M8-M12 dia. w/Nuts	3	24	98-DL24
512MK	METRIC CLASS 8.8 COARSE M4-M10 dia. w/Nuts and Washers	4	22	13-994
40-112	METRIC ALLOY CLASS 10.9 COARSE M6-M12 dia. w/Nuts and Washers	2	32	98-40B
40-111	STAINLESS STEEL T18-8, NC w/Nuts and Washers, 1/4-1/2 to 3"	2	32	98-40B
16-4924	STAINLESS STEEL T18-8, NC w/Nuts and Washers, 1/4-1/2 to 1/2"	3	24	98-DL24



## NUTS & WASHERS

16-0220	NUTS, GRADE C OVAL LOCK, NC and NF 1/4-1" dia., zinc plated alloy steel, waxed	3	20	98-DL20
535MK	NUTS, GRADE C OVAL LOCK, NC, 1/4-5/8" dia., zinc plated alloy steel, waxed	4	6	13-995
536MK	NUTS, GRADE C OVAL LOCK, NF 1/4-5/8" dia., zinc plated alloy steel, waxed	4	102	13-995
529MK	NUTS, CASTLE, NF 1/4-5/8" dia., zinc plated steel	4	6	13-995
532MK	NUTS, GRADE 5 FINISHED HEX, NC, 1/4-5/8" dia., zinc plated steel	4	6	13-995
528MK	NUTS, GRADE 5 FINISHED HEX, NF 1/4-5/8" dia., zinc plated steel	4	6	13-995
509MK	NUTS, KEP® LOCK, 8-32, 10-24, 10-32 (NF), 1/4-20, 5/16-18, 3/8-16, zinc plated steel	4	6	13-995
526MK	NUTS, METRIC FINISHED HEX, CLASS 8 COARSE, M4-M12 dia., zinc plated steel	4	6	13-995
527MK	NUTS, NYLON LOCK, NF 1/4-5/8" dia., zinc plated steel	4	6	13-995
507MK	NUTS, NYLON LOCK, NC, 1/4-5/8" dia., zinc plated steel	4	6	13-995
16-0120	NUTS, NYLON LOCK, NC and NF, no.10-3/4" dia., zinc plated steel	3	18	98-DL20
533MK	NUTS, SLOTTED, NC 1/4-5/8" dia.	4	6	13-995
534MK	NUTS, SLOTTED, NF 1/4-5/8" dia.	4	6	13-995
508MK	NUTS, WING, NC #8-1/2" dia., zinc plated forged steel	4	6	13-995
16-0720	WASHERS, EXTRA THICK SAE FLAT ALLOY, sizes 1/4-3/4 dia., zinc dichromate	3	8	98-DL20
16-0324	WASHERS, SHAKEPROOF, Internal and External, 6-5/8" dia., zinc plated steel	3	24	98-DL24
510MK	WASHERS, SHAKEPROOF, External, 6-1/2" dia., zinc plated steel	4	9	13-997

• NEW ASSORTMENT

**MPI CAN BECOME YOUR SINGLE-SOURCE SUPPLIER ON  
MANY OF THE PARTS YOU CURRENTLY USE!**



# Assortments



## SCREWS

Part No.	Description	Bin Type	No. Sizes	Cabinet
16-4712	DRYWALL AND DECK, Phillips Twinfast, Black Oxide, w/insert bits and holder	3	11	98-DL12
16-5012	CONCRETE SCREWS, Hex and flat head, 3/16" & 1/4" dia. to 3-1/4" lg., w/drills (space for installation kit)	3	11	98-DL12
16-1824	MACHINE, Flat Hd. Slotted, zinc plated steel, 6-1/4-1 1/2 w/Nuts	3	24	98-DL24
16-4624	MACHINE, Flat Hd. Slotted, Brass, 6,8,10 and 1/4 w/Nuts	3	24	98-DL24
16-1524	MACHINE, Round Hd. Slotted, zinc plated steel, 6-1/4-1 1/2 w/Nuts	3	24	98-DL24
16-1624	MACHINE, Round Hd. Slotted, zinc plated steel, 6-12 to 1 1/2 w/Nuts	3	24	98-DL24
16-1724	MACHINE, Round Hd. Slotted, zinc plated steel, 6-1/4 to 2" w/Nuts	3	24	98-DL24
502MK	MACHINE, Round Hd. Slotted, zinc plated steel, 6,8,10 (NC only) w/Nuts	4	12	13-996
503MK	MACHINE, Round Hd. Slotted, zinc plated steel, 6,8,10, 1/4 w/Nuts	4	18	13-993
504MK	MACHINE, Round Hd. Slotted, zinc plated steel, 10-32,12,1/4 w/Nuts	4	12	13-996
16-2224	MACHINE, Round Hd. Slotted, 18-8 Stainless Steel, 6-1/4 to 1 1/2 w/Nuts	3	24	98-DL24
16-3924	MACHINE, Pan Head Phillips Steel, 1/4 to 1 1/2 w/Nuts	3	24	98-DL24
16-2924	MACHINE, METRIC Pan Head Phillips Steel, 3mm - 8mm dia. to 40mm	3	24	98-DL24
16-4524	MACHINE, Round Hd. Slotted, Brass, 6-1/4 to 1 1/2 w/Nuts	3	24	98-DL24
16-1324	SHEET METAL, Hex Wshr. Hd. Slotted and Unslotted, zinc plated steel, 6-5/16	3	24	98-DL24
16-1424	SHEET METAL, Hex Hd., Zinc, 6-3/8 to 2"	3	24	98-DL24
16-0924	SHEET METAL, Oval Hd. Phillips, zinc plated steel, 6-14 to 1 1/2	3	24	98-DL24
16-1024	SHEET METAL, Oval Hd. Phillips, Black Oxide, steel, 6-10 to 1 1/2	3	24	98-DL24
16-0724	SHEET METAL, Pan Hd. Slotted, zinc plated steel, 6-14 to 1 1/2	3	24	98-DL24
500MK	SHEET METAL, Pan Hd. Slotted, zinc plated steel, 6-14 to 1 1/4	4	12	13-994
16-2324	SHEET METAL, Pan Hd. Slotted, Stainless steel, 6-14 to 1 1/2	3	24	98-DL24
16-0824	SHEET METAL, Pan Hd. Phillips, zinc plated steel, 6-14 to 1 1/2	3	24	98-DL24
501MK	SHEET METAL, Pan Hd. Phillips, zinc plated steel, 6-14 to 1 1/4	4	12	13-994
16-5124	SHEET METAL, Pan Hd. Phillips Stainless steel, 6-14 to 1 1/2	3	24	98-DL24
16-1124	SHEET METAL, Pan and Round (OEM) Phillips Trim, Black Oxide, steel, 6-10 to 1 1/2	3	24	98-DL24
547MK	SHEET METAL, ONE-WAY SECURITY, Round Hd., zinc plated steel, 6-14 to 1"	4	11	13-994
16-0620	TEKS (Self-Drilling), Hex and Pan Hd., 8,10,12 and 14 dia., zinc plated steel	3	20	98-DL20
505MK	TEKS (Self-Drilling), Hex Hd., 8,10,12 and 14 dia., zinc plated steel	4	6	13-995
16-1924	THREAD CUTTING, Hex Hd., NC threads, 6-3/8 dia., zinc plated steel	3	24	98-DL24
16-2124	WOOD FLAT Hd. Slotted, 6-14 dia., zinc plated steel	3	24	98-DL24



## SOCKET SCREWS

16-0424	SOCKET HEAD CAP SCREWS, NC sizes 1/4-1/2 to 2-1/2"	3	24	98-DL24
16-2624	METRIC SOCKET CAPSCREWS, CLASS 12.9 COARSE, M4-M12 dia.	3	24	98-DL24
16-2724	METRIC SOCKET CAPSCREWS, FLAT HEAD, CLASS 10.9 COARSE, M4-M12 dia.	3	24	98-DL24
16-0524	FLAT SOCKET HEAD CAP SCREWS, NC sizes 1/4-1/2 to 2 1/2"	3	24	98-DL24
16-0624	SOCKET SET SCREWS, NC, cup Point, 6-5/8" dia.	3	24	98-DL24
506MK	SOCKET SET SCREWS, NC and NF, cup Point, No.6-3/8" dia.	4	18	13-993
16-2824	METRIC SOCKET SET SCREWS, CLASS 12.9 COARSE, M3-M12 dia.	3	24	98-DL24



## THREAD REPAIR KITS

537MK	E-Z LOK®, NC, sizes 1/4-3/4" dia.	4	8	13-997
538MK	E-Z LOK®, NF sizes 1/4-3/4" dia. (9/16" not included)	4	7	13-997
33004	RECOIL®, NC Master Range Kit; sizes 1/4-1/2 Inserts, interchangeable with Heli-Coil inserts	-	5	Case
34004	RECOIL® NF Master Range Kit; sizes 1/4-1/2 interchangeable with Heli-Coil inserts	-	5	Case



## HOSE CLAMPS

2396	HOSE CLAMPS, STANDARD partial stainless worm-drive clamps, sizes 4 - 36 and deluxe wire rack	-	10	2398
2397	HOSE CLAMPS, ALL STAINLESS STEEL worm-drive clamps, sizes 4 - 36 and deluxe wire rack	-	10	2398
540MK	HOSE FERRULES, BRASS, for assembling low pressure hoses up to .850" OD	4	6	13-995



## ANCHORS

511MK	ANCHORS, PLASTIC, 6-8, 10-12, 14-16 with tapping screws (no drills)	4	6	13-995
23-114	ANCHORS, PLASTIC, 6-8 with tapping screws and concrete drill	4	2	Plastic
23-115	ANCHORS, PLASTIC, 10-12 with tapping screws and concrete drill	4	2	Plastic
23-116	ANCHORS, PLASTIC, 12-14 with tapping screws and concrete drill	4	2	Plastic
546MK	ANCHORS, NYLON WALLBOARD, also includes pan hd. tapping screws and flat washers	4	5	13-995
541MK	ANCHORS, ZINC WALLBOARD, also includes pan hd. tapping screws and flat washers	4	5	13-995
16-5012	CONCRETE SCREW, hex and flat head, 3/16" and 1/4" dia., special concrete screw drills included	3	11	98-DL12

• NEW ASSORTMENT

# Assortments



## FITTINGS

Part No.	Description	Bin Type	No. Sizes	Cabinet
16-4024	AIRBRAKE COMPRESSION FITTINGS, Brass, 1/4-1/2 OD tube (for copper airbrake tubing)	3	24	98-DL24
16-4124	AIRBRAKE NTA FITTINGS, Brass, 1/4-5/8 OD tube (for nylon airbrake tubing)	3	24	98-DL24
16-0332	COMPRESSION FITTINGS, Brass, 1/8-3/8 OD tube	3	32	98-DL32
16-0432	COMPRESSION FITTINGS, Brass, 1/4-5/8 OD tube	3	32	98-DL32
16-4224	FLARE FITTINGS, SAE 45°, Brass 1/4-1/2 OD tube	3	24	98-DL24
520MK	GREASE FITTINGS, STANDARD 1/4-28 and 1/8PT straight, 45° angle and 90° angle, some long lengths	4	13-997	
521MK	GREASE FITTINGS, STANDARD 1/4-28 and 1/8PT straight, 45° angle and 90° angle	4	6	13-995
522MK	GREASE FITTINGS, METRIC, M6x1.0, M8x1.0, M10x1.0 pitch in straight, 45° angle and 90° angle	4	9	13-997
16-6524	GREASE FITTINGS, STANDARD straight, 45° angle and 90° angle, DRIVE TYPE and METRIC straight, w/ dust caps	3	18	98-DL24
40-105	HYDRAULIC HOSE ENDS & ADAPTERS, Parker series 43 ends, 1/4-1" I.D. with popular adapters	2	26	98-40B
16-6024	INSTANT PUSH-IN FITTINGS, ACETYL, 1/4 and 3/8" OD	3	19	98-DL24
16-5924	INSTANT PUSH-IN FITTINGS, BRASS INDUSTRIAL, 1/8 to 1/2" tube OD	3	19	98-DL24
16-6124	INSTANT PUSH-IN FITTINGS, BRASS AIRBRAKE, 1/8 to 1/2" tube OD	3	19	98-DL24
16-4324	INVERTED FLARE, Brass, for 3/16-3/8 OD steel tubing	3	24	98-DL24
16-5632	PIPE FITTINGS, BLACK 150# MALL. IRON, 1/8-1/2 NPT	3	28	98-DL32
40-107	PIPE FITTINGS, BLACK 150# MALL. IRON, 1/8-3/4 NPT	2	34	98-40B
40-117	PIPE FITTINGS, BLACK 150# MALL. IRON, 150#, 1"-2" NPT	2	28	98-40B
16-5732	PIPE, GALVANIZED 150# MALL. IRON, 1/8-1/2 NPT	3	28	98-DL32
40-108	PIPE, GALVANIZED IRON, 150#, 1/8-3/4 NPT	2	34	98-40B
40-118	PIPE, GALVANIZED 150# MALL. IRON, 150#, 1"-2" NPT	2	28	98-40B
16-0232	PIPE FITTINGS, BRASS HEX, 1/8-3/8 NPT elbows, plugs, tees, couplers, bushings, nipples	3	32	98-DL32
16-5832	PIPE FITTINGS, BRASS, 1/8-1/2 NPT elbows, plugs, tees, couplers, bushings, nipples	3	28	98-DL32
16-5624	PIPE NIPPLES, BLACK 150# MALL. IRON, 1/8-1/2 NPT	3	20	98-DL24
40-109	PIPE NIPPLES, BLACK 150# MALL. IRON, 150#, 1/8-3/4 NPT	2	35	98-40B
40-119	PIPE NIPPLES, BLACK 150# MALL. IRON, 150#, 1"-2" NPT	2	24	98-40B
16-5824	PIPE NIPPLES, BRASS, 1/8-1/2 NPT	3	20	98-DL24
16-5724	PIPE NIPPLES, GALVANIZED 150# MALL. IRON, 1/8-1/2 NPT	3	20	98-DL24
40-110	PIPE NIPPLES, GALVANIZED 150# MALL. IRON, 150#, 1/8-3/4 NPT	2	35	98-40B
40-120	PIPE NIPPLES, GALVANIZED 150# MALL. IRON, 150#, 1"-2" NPT	2	24	98-40B
16-0420	PUSH-ON FITTINGS, BRASS, 1/4-5/8 ID hose barsbs and menders (for low pressure push-on hose)	3	20	98-DL20



## ELECTRICAL TERMINALS

16-5212	BATTERY TERMINALS, FUSION™ TYPE, 1 & 2 GA, 1/0 AND 2/0 TERMINALS, SHINK TUBING INCLUDED	3	12	98-DL12
16-2024	ELEKTRALINK, SEALED SOLDER, 24-10 awg	3	19	98-DL24
542MK	ELEKTRALINK, SEALED SOLDER, 20-10 awg, Ring Terminals and Butt Connectors	4	6	13-995
16-5521	KRIMP 'N SEAL, 22-10 awg with heat shrink insulation	3	16	98-DL21
548MK	POSI-LOCK™ BUTT CONNECTORS, 24 - 8 awg. <b>No tools required!</b>	4	3	13-995
16-3724	SOLDERLESS, NYLON w/Ins. Grip, 22-10 awg, includes T-Taps	3	24	98-DL24
16-3824	SOLDERLESS, NYLON w/Ins. Grip, 22-10 awg, includes Scotchlocks	3	24	98-DL24
523MK	SOLDERLESS, NYLON w/Ins. Grip, 16 - 14 awg (blue), includes Scotchlocks	4	9	13-997
524MK	SOLDERLESS, NYLON w/Ins. Grip, 22-10 awg	4	12	13-996
531MK	SOLDERLESS, NYLON w/Ins. Grip, 22-10 awg, includes T-Taps	4	12	13-996
16-0520	SOLDERLESS, VINYL INSULATED, 22-10 awg, includes Scotchlocks	3	20	98-DL20
530MK	SOLDERLESS, VINYL INSULATED, 22-10 awg	4	12	13-996
525MK	WIRE NUTS, gray, blue, orange, yellow and red	4	6	13-995



## O-RINGS

16-3524	O-RING ASSORTMENT, Buna N Rubber, 1/4 thru 2-1/8" OD (1/16", 3/32", 1/8" & 3/16" dia.)	3	24	98-DL24
16-6232	1/16" O-RING ASSORTMENT, Buna N Rubber, 1/4 thru 2-3/8" OD (all 1/16" dia.)	3	30	98-DL32
16-6324	1/32" O-RING ASSORTMENT, Buna N Rubber, 5/16 thru 1-11/16" OD (all 1/32" dia.)	3	24	98-DL24
16-6432	1/8" O-RING ASSORTMENT, Buna N Rubber, 3/4 thru 3-1/2" OD (all 1/8" dia.)	3	32	98-DL32
519MK	MAINTENANCE KIT, Buna N Rubber, 1/4-1-3/16 OD (1/16", 3/32", 1/8" dia.)	4	18	13-993
10-675	PLUMBERS' KIT, Buna N Rubber, 3/8-1-1/8" OD	4	12	Plastic
10-676	UNIVERSAL KIT, Buna N Rubber, 1/4-2-1/8" OD	4	30	Plastic
10-677	VITON KIT, Special High Temperture Viton Rubber, 1/4"- 2-1/8" OD	4	30	Plastic
AV-15961	METRIC KIT, Buna N Rubber, M5.4 - M24 OD	4	36	Plastic

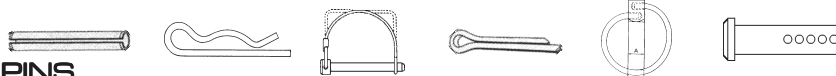

## PINS

16-0320	ASSORTED PINS, Cotter Pins, Hitchpin Clips, Lynch Pins and Wire Lock Pins	3	20	98-DL20
16-3224	CLEVIS, standard and universal, 3/16-1/2" dia.	3	24	98-DL24
16-3024	COTTER, 1/16-1/4" dia., zinc plated steel	3	24	98-DL24
515MK	COTTER, 1/16-3/16 dia., zinc plated steel	4	6	13-995
514MK	HITCH PIN CLIPS, 1/4-1" shaft size.	4	6	13-995
16-5224	SPIROL (COILED) 1/16-5/16 dia., plain finish steel	3	24	98-DL24
16-0132	SPRING (ROLL), 1/16-1/2 dia., zinc plated steel	3	32	98-DL32
513MK	SPRING (ROLL), 1/16-3/8 dia., zinc plated steel	4	32	13-994

• NEW ASSORTMENT



# Assortments



## RETAINING RINGS

Part No.	Description	Bin Type	No. Sizes	Cabinet
16-3324	EXTERNAL AND INTERNAL, shaft sizes to 1/2"	3	24	98-DL24
16-3424	EXTERNAL, INTERNAL, AND E-TYPE, sizes to 1"	3	24	98-DL24
516MK	EXTERNAL, 1/4-1-1/4" shaft dia.	4	12	13-994
517MK	E-TYPE, 1/16-3/4" shaft dia.	4	12	13-994



## KEYSTOCK & WOODRUFF KEYS

545MK	KEYS, MACHINERY, SQUARE STEEL, 1/8"-3/8" x 1-1/2"	4	6	Plastic box
20-139	KEYSTOCK, SQUARE STEEL, 1/8-1/2" x 12" in metal stand	-	7	20-140
16-5106	KEYSTOCK, SQUARE STEEL, 1/8-1/2" x 12" in steel drawer	3	7	98-DL6H
20-751	KEYSTOCK, SQUARE STAINLESS STEEL, 1/8-1/2" x 12" in metal stand	-	7	20-140
16-3624	WOODRUFF KEYS, Sizes 3/32-3/8, plain finish	3	24	98-DL24
518MK	WOODRUFF KEYS, Sizes 3/32-5/16, plain finish	4	18	13-993



## CUTTING TOOLS

1224	CAR REAMER SET, 1/2, 5/8 and 3/4" dia. in custom hardwood case	-	3	wood case
5983	CARBIDE BURS, Double-Cut Flutes, 1/4" shank in custom hardwood case	-	8	wood case
5987	DRILL SET, 1/2" REDUCED SHANK, 9/16-1"x16ths, 118° standard point	5	8	5967
1496	DRILL SET, AIRCRAFT STRAIGHT SHANK, Type B, 1/16 to 1/2 x 64ths, 135° split pt.	5	29	6003
5999	DRILL SET, AIRCRAFT STRAIGHT SHANK, Type B, 1/16 to 3/8 x 64ths, 135° split pt.	5	21	5971
6006	DRILL SET, AIRCRAFT STRAIGHT SHANK, Type B, 1/16 to 1/2 x 32nds, 135° split pt.	5	15	5970
1558	DRILL SET, BRUTE™ 1/2 REDUCED SHANK, 9/16-1"x16ths, 118° split pt.	5	8	5967
5989	DRILL SET, BRUTE™ 3/8 REDUCED SHANK, 1/16 to 1/2 x 64ths, 135° split pt.	5	29	6003
1499	DRILL SET, BRUTE™ STRAIGHT SHANK, Type B, 1/16 to 1/2 x 64ths, 135° split pt.	5	29	6003
5994	DRILL SET, BRUTE™ STRAIGHT SHANK, Type B, 1/16 to 3/8 x 64ths, 135° split pt.	5	21	5971
5995	DRILL SET, BRUTE™ STRAIGHT SHANK, Type B, 1/16 to 1/2 x 32nds, 135° split pt.	5	15	5970
5998	DRILL SET, BRUTE™ STRAIGHT SHANK, Type B, WIRE SIZES #1 - 60 (#1-#47 are 135° split pt.)	5	60	6004
5997	DRILL SET, BRUTE™ STRAIGHT SHANK, Type B, LETTER SIZES A to Z, 135° split pt.	5	26	6005
6010	DRILL SET, COBALT STRAIGHT SHANK, Type J, 1/16 to 1/2 x 64ths, 135° split pt.	5	29	6003
5991	DRILL SET, COBALT STRAIGHT SHANK, Type J, 1/16 to 3/8 x 64ths, 135° split pt.	5	21	5971
5992	DRILL SET, COBALT STRAIGHT SHANK, Type J, 1/16 to 1/2 x 32nds, 135° split pt.	5	15	5970
5993	DRILL SET, COBALT STRAIGHT SHANK, Type J, 1/16 to 1/4 x 32nds, 135° split pt.	5	13	5968
5972	DRILL/TAP SET, BRUTE™ NC Spiral Point Taps 6-32 - 1/2-13 with Brute™ drills	5	18	5966
5973	DRILL/TAP SET, BRUTE™ NF Spiral Point Taps 6-40 - 1/2-20 with Brute™ drills	5	18	5969
NES-123	THREAD RESTORING KIT contains NES1A, NES2, NES3, Internal thread cleaner, extension rod, extra blades	-	-	Case
5958	TAP and DIE SET, NC and NF #4-1/2", carbon steel plug taps and solid round dies	-	-	Case
5959	TAP and DIE SET, METRIC sizes M3-M12, carbon steel plug taps and solid round dies	-	-	Case

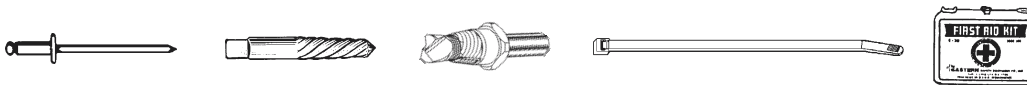

## MISCELLANEOUS

16-5306	CABLE TIES, BLACK NYLON, 4" - 15" with steel drawer	3	6	98-DL6H
29-434	CABLE TIES, BLACK NYLON, 4" 7" and 11" in resealable clamshell container	-	3	Clam-Shell
16-5406	CABLE TIES, WHITE NYLON, 4" - 15" with steel drawer	-	6	98-DL6H
29-432	CABLE TIES, WHITE NYLON, 4" 7" and 11" in resealable clamshell container	-	3	Clam-Shell
5985	EXTRACTORS, SPIRAL FLUTE WITH L.H. DRILLS, #1 thru #5 with sturdy metal index	5	10	Index
50-261	EXTRACTORS, SPIRAL FLUTE, #1 thru #5 in plastic pouch	-	5	Pouch
539MK	EXTRACTORS, STRAIGHT FLUTE WITH L.H. DRILLS, #1 thru #5	4	10	13-995
5964	DRILL-OUT POWER EXTRACTORS, REGULAR SET, sizes 1/4, 5/16, 3/8, 1/2	5	4	Case
5965	DRILL-OUT POWER EXTRACTORS, MICRO SET, sizes 6, 8, 10, 1/4, 5/16, 3/8, 1/2	8	7	Case
17-180	FIRST AID KIT, DELUXE, meets OSHA requirements. <b>Weatherproof sealed metal cabinet</b>	-	-	Metal
17-180R	FIRST AID KIT REFILL (no cabinet)	-	-	Metal
16-5532	FUSES, AUTOMOTIVE, Glass fuses, ATC standard blade, ATM mini blade and fuseholders	3	30	98-DL32
549MK	FUSES, AUTOMOTIVE, ATM mini blade fuses	4	8	13-994
31-710	GASKET MATERIAL, rubber, cork, and fiber. 6 inch square pieces.	-	3	Boxed
16-4706	HEAT SHRINK TUBING, MEDIUM WALL, 3/16-3/4" x 16"	3	6	98-DL6H
16-5206	HEAT SHRINK TUBING, HEAVY WALL, .300" - 2.00" x 12"	3	6	98-DL6H
6648	HOLE SAW SET, TRADITIONAL ARBORS, Bi-metal, variable pitch, 3/4 to 2 1/2 dia., 3 arbors, 3 drills, 12" extension	4	15	Case
6647	HOLE SAW SET, BUILT-IN ARBORS, Bi-metal, variable pitch, 3/4 to 2 1/2, 4 drills, 12" extension	4	15	Case
16-5506	RECIPROCATING SAW BLADES, Bi-metal, 4" to 8" long "Sawzall" style blades	3	6	98-DL6V
20-916	RIVET TOOL KIT, includes Marson heavy duty riveter (20-915) and 1/8" dia. A/A and A/S blind rivets	-	2	Case
16-4806	RIVETS, BLIND, 1/8" and 3/16" dia. A/A rivets (space for optional riveter)	3	6	98-ADL
12-056	SHIM STOCK, 6" x 12" flat steel sheets, .001" to .031" thickness	-	15	Box

• NEW ASSORTMENT

# Storage Bins

All of these bins allow easy access to parts and each compartment is open for speedy inspection and search. Front lips designed to retain parts and are wide enough for stick-on labels. All edges are burr-free.

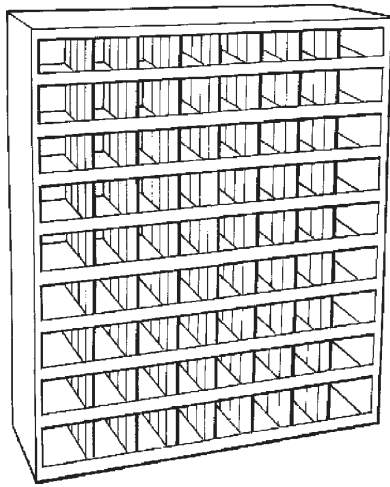

## 98-72B / 72 Hole Bin

America's most popular storage bin. The 72 Hole Bin will accommodate medium to large size parts such as bolts and fittings.

Bin size: 35"W x 42"H x 12"D

Comp. size: 4"W x 4-5/8"H

Material: 22 ga. steel

Finish: Gray enamel

Shipping wt.: 125 lbs. (Truck only)

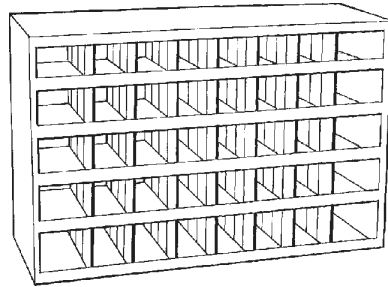

## 98-40B / 40 Hole Bin

Stack or stand two side-by-side for a 80 hole bin that can be shipped UPS.

Bin size: 35"W x 24"H x 12"D

Comp. size: 4"W x 4-1/8"H

Material: 22 ga. steel

Finish: Gray enamel

Shipping wt.: 65 lbs. (UPS-able)

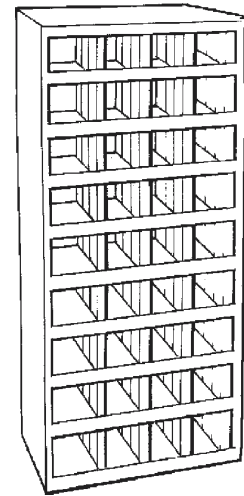

## 98-36B / 36 Hole Bin

Stand two narrow 36 Hole Bins side-by-side for a 72 hole bin that can be shipped UPS.

Bin size: 17-1/2"W x 42"H x 12"D

Comp. size: 4"W x 4-5/8"H

Material: 22 ga. steel

Finish: Gray enamel

Shipping wt.: 50 lbs. (UPS-able)

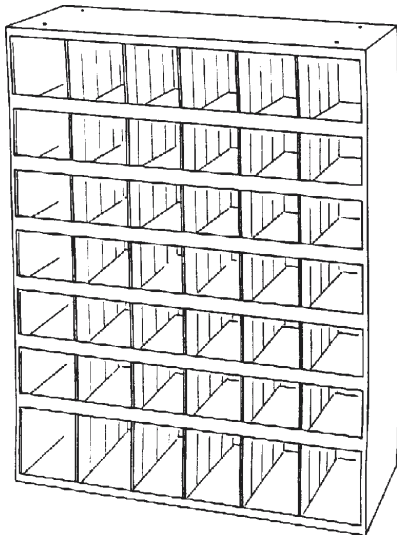

## 98-42B / 42 Hole Bin

Extra-large compartment size for bulky parts such as pipe fittings.

Bin size: 35"W x 42"H x 12"D

Comp. size: 5-1/2"W x 6"H

Material: 22 ga. steel

Finish: Gray enamel

Shipping wt.: 100 lbs. (Truck only)

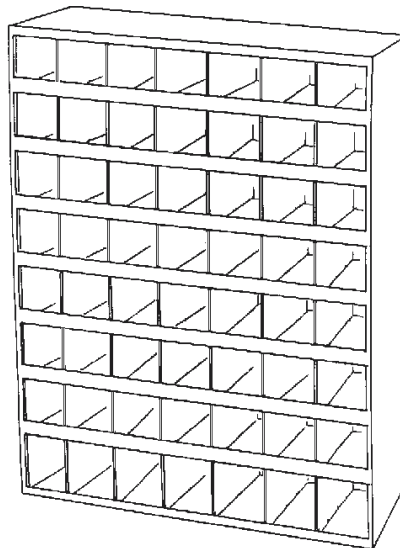

## 98-56B / 56 Hole Bin

Large compartment size for easier access to bulk parts.

Bin size: 35"W x 42"H x 12"D

Comp. size: 4-3/4"W x 5-1/4"H

Material: 22 ga. steel

Finish: Gray enamel

Shipping wt.: 110 lbs. (Truck only)

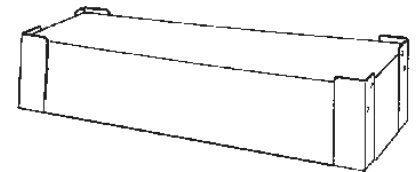

## 98-BBC / Base

For storage bins above to raise units 6-1/2".

Size: 35-3/8"W x 6-1/2"H x 12"D

Shipping wt.: 10 lbs.



# Slide Racks for Steel Drawers

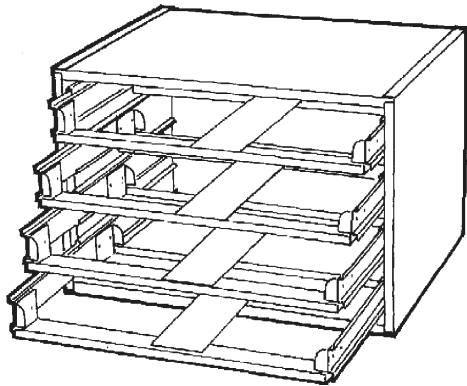

**98-4SR**  
**Small Four Drawer Slide Rack**  
15-1/4"W x 11-3/4"D x 11-1/4"H

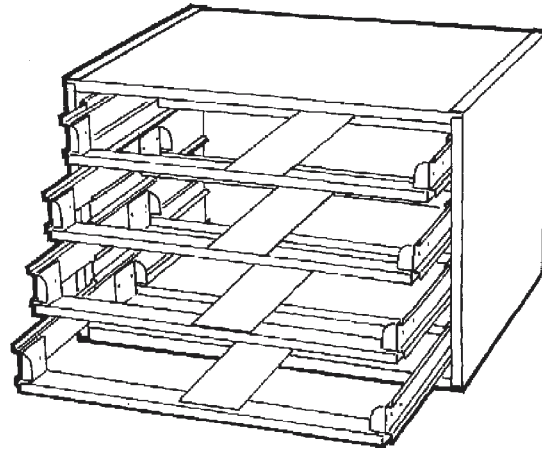

**98-4LR / Large Four  
Drawer Slide Rack**  
20"W x 15-3/4"D x 15"H

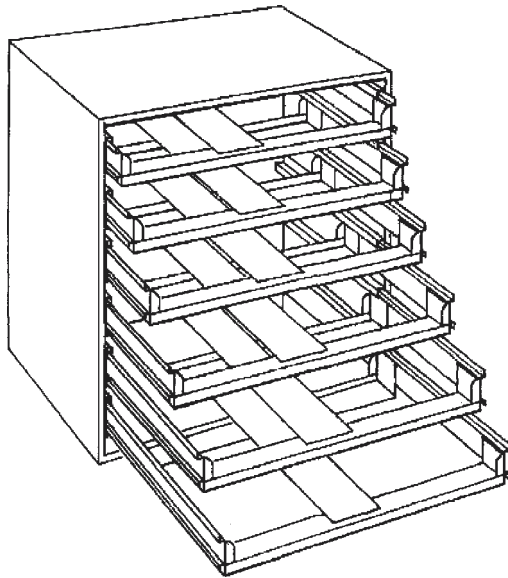

**98-6SR**  
**Small Six Drawer Slide Rack**  
15-1/4"W x 11-3/4"D x 16-5/16"H

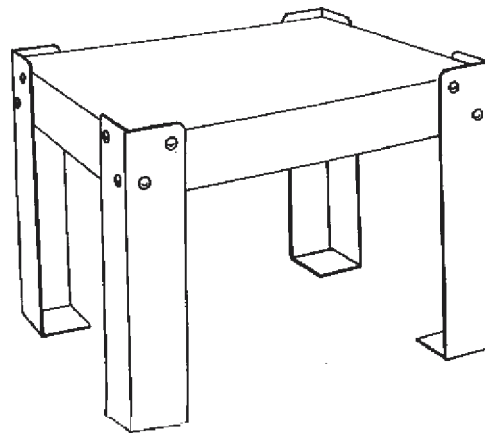

**98-BLR**  
**Large Rack Base**  
Raises rack 18" above  
floor.

*Note: drawers are not included with racks.*

# Steel Parts Drawers

Perfect for small screws and fittings. Gray baked-on enamel finish. Durable 24 gauge steel shell. Impact resistant plastic tray inserts resist rust and corrosion. Easy-to-scoop compartments have no seams to lose small parts. Built for years of rugged use. Each drawer provided with strong steel handle and a secure lid latch for job-site transport.

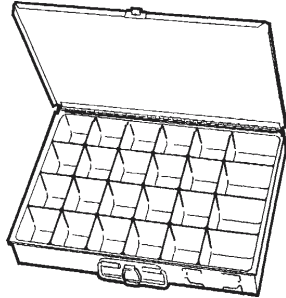

## SMALL DRAWERS

(98-DS24 shown above)

SIZE: 2"H x 9-3/8"D x 13-3/8"W  
Will fit slide racks 98-4SR, 98-6SR

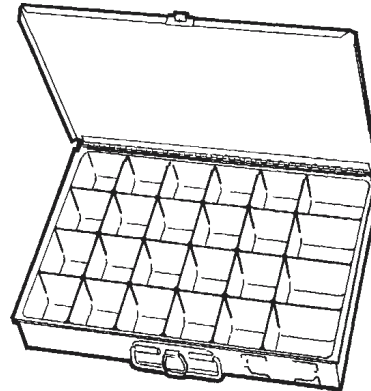

## LARGE DRAWERS

(98-DL24 shown above)

SIZE: 3"H x 12"D x 18"W  
Will fit slide rack #98-4LR

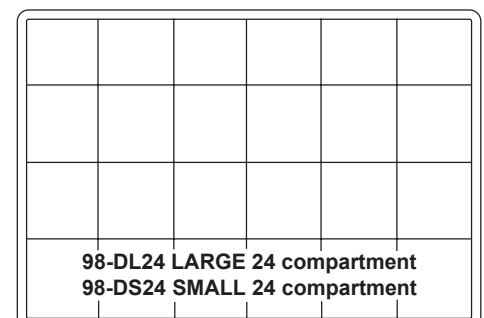
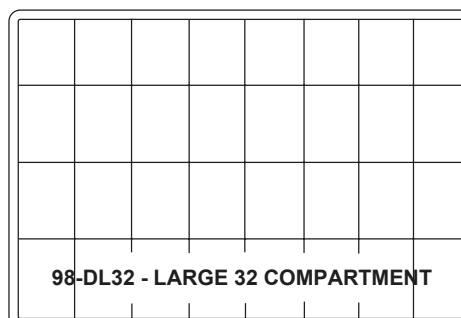
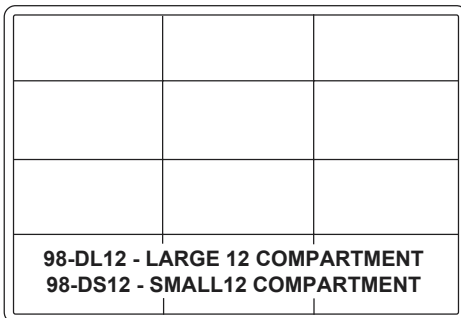
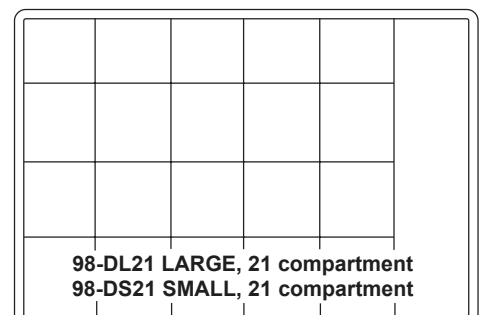
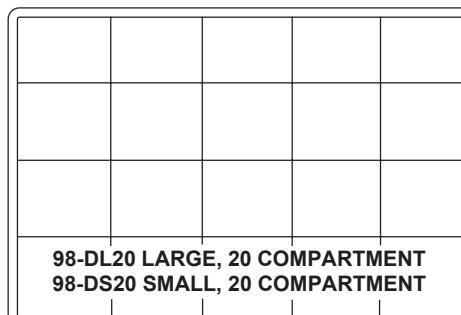
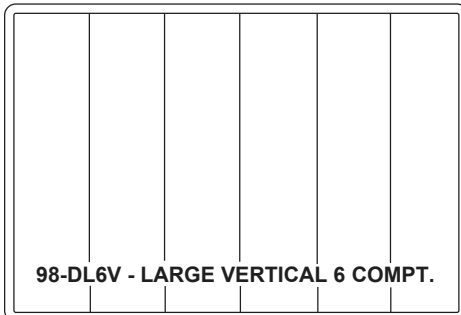
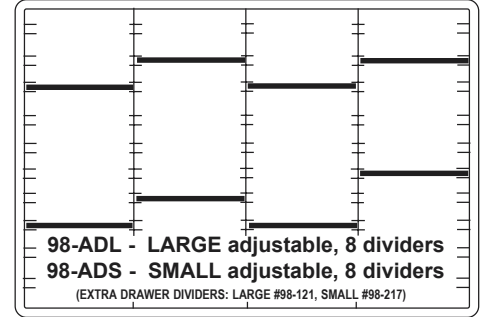
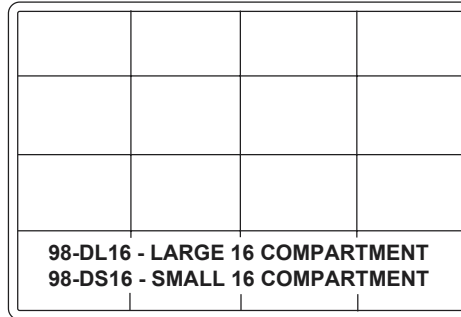
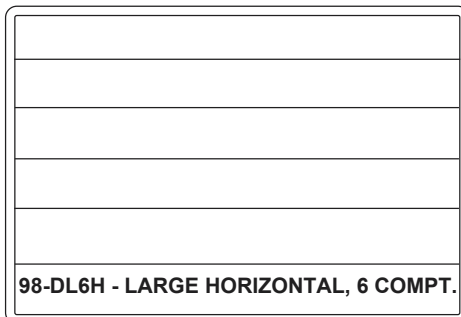

# Steel Cabinets

## With Adjustable Dividers

### FEATURES

- Quality 24 gauge steel construction thru-out • Shipped fully assembled
- Smooth drawer face for adhesive labels • Gray baked-on enamel finish
- Stackable for expandability • Positive drawer stops prevent accidental removal
- Partition slots on 1" centers • Each cabinet supplied with two dividers per drawer

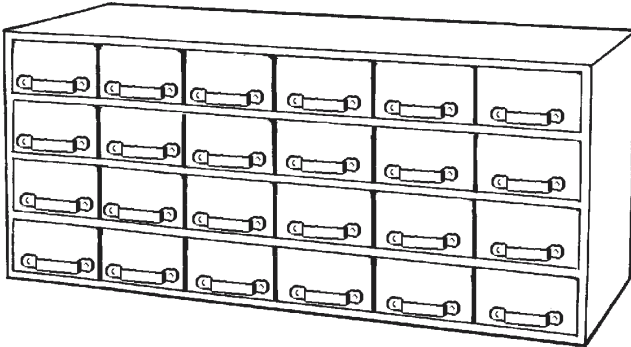

#### 98-24D / 24 Drawer Cabinet

Cabinet size:

14-1/4"H x 11-1/2"D x 34"W

Drawer inside dimensions:

2-3/4"H x 5-3/8"W x 11-1/4"D

Shipping wt.: 60 lbs.

No. of Dividers: 48

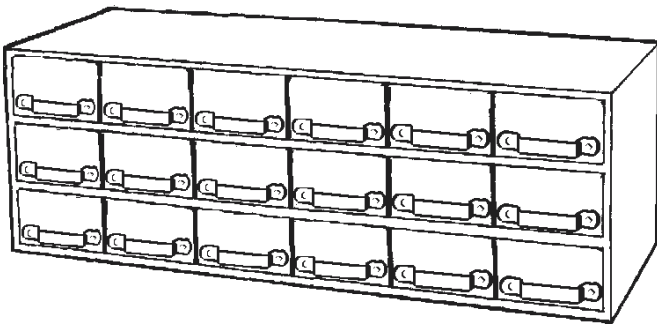

#### 98-18D / 18 Drawer Cabinet

Cabinet size:

10-3/4"H x 11-1/2"D x 34" W

Drawer inside dimensions:

2-3/4"H x 5-3/8"W x 11-1/4"D

Shipping wt.: 50 lbs.

No. of Dividers: 36

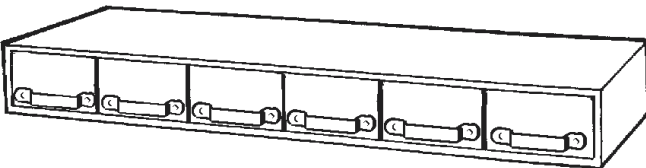

#### 98-6D / 6 Drawer Cabinet

Cabinet size:

4"H x 11-1/2"D x 34"W

Drawer inside dimensions:

2-3/4"H x 5-3/8"W x 11-1/4"D

Shipping wt.: 21 lbs.

No. of Dividers: 12



#### 98-010 / Cabinet Dividers

Size: 2-1/2" x 5-3/16"

Steel divider for any of the above steel cabinets.

#### 98-BD / Steel Cabinet Base

Size: 15H" x 34"W x 11-3/4"D

Raises steel cabinets 15" above floor. Use with any of the above.

*(Not pictured)*

*Individual drawers available upon special request*



# Miscellaneous Storage Units

## Key Stock Rack

Holds 10 sizes.  
Size: 10-1/2"W x 6"H x 5"D. Compartment size: 1-1/2" x 1-1/2". Shipping wt. 3 lbs. **Part No. 20-140**

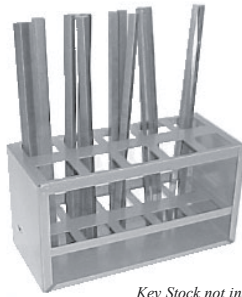

*Key Stock not included.*

## Welding Rod Cabinet

Used for welding rods, keystack and long bolts up to 18 inches long. Compartment measures 4"H x 5 1/4"W. Cabinet size is 18 1/2"D x 8"H x 16"W. **Part No. 98-WRC**

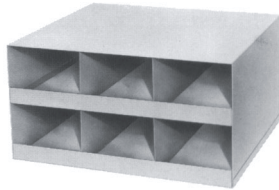

## Threaded Rod Storage Rack

This rack organizes and protects up to 6' long rods, round bars and other steel stock. Has eighteen openings (2-1/16" dia.) Size: 24-1/8"W x 24"H x 6-7/8"D. Made from heavy gauge cold rolled steel. Comes assembled. Color is gray. **Part no. 99-112**

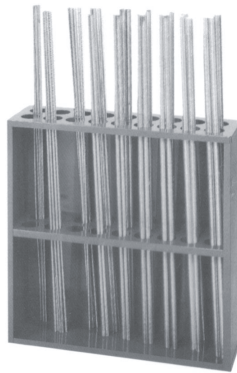

*(Threaded Rods not included)*

## Adjustable Storage Bin

Features removable vertical dividers allowing multi-width compartments. Scoop front lips allow easy small parts removal. Perfect for small parts, metric fasteners and more. Wall-mountable. Gray baked enamel. shipping Wt. 25 lbs. No. of bins: 36. Bin size: 23-3/4"W x 23-3/4"H x 4-3/4"D. Compartment size: 3-7/8" x 3-3/4" x 4-5/8" **Part No. 98-MB36**

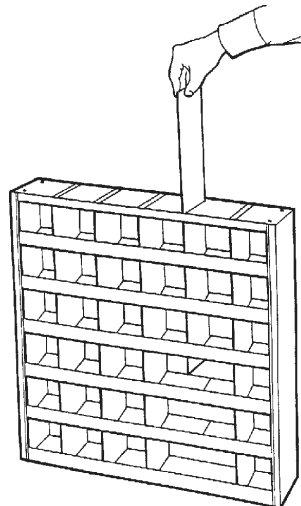

## Wire Spool Truck

Accommodates spools of battery cable, small wire rope, 500 ft. spools of THHN and 2,500 ft. reels of Romex. Size: 23 1/2" wide x 46" high x 24" deep. **Part No. 29-436**

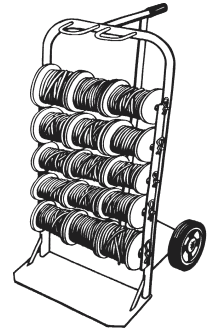

## Adapter for Wire Spool Truck.

Expand capacity without the expense of an additional truck. Size: 18 3/4" wide x 33 1/4" high x 18" deep. **Part No. 29-438**

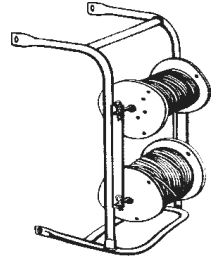

## Portable Wire Caddy

A real time saver for small jobs. Wire is easy to pull and control. Size: 21 1/4" wide x 11 1/2" deep. **Part No. 29-442**

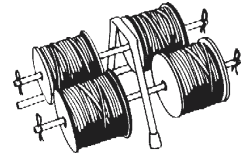

## Wire Spool Racks

Convenient for dispensing wire. Holds spools up to 10" in diameter. Unit is easy to assemble and wall mountable. Gray baked enamel finish. Shipping weight: 25 lbs. Size: 26-1/8"W x 37-1/8"H x 6"D. **Part No. 98-WSR-4**

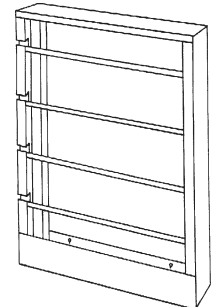

## Aerosol Storage Cabinet

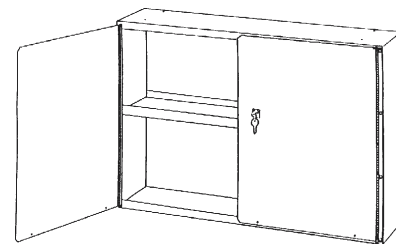

Divided into four sections. Includes lock and two keys. Easily wall mounted using keyholes provided. Gray baked enamel finish. Shipping wt. 45 lbs. Size: 34"W x 22"H x 8-1/2"D. **Part No. 98-343**



# Satchel Cases

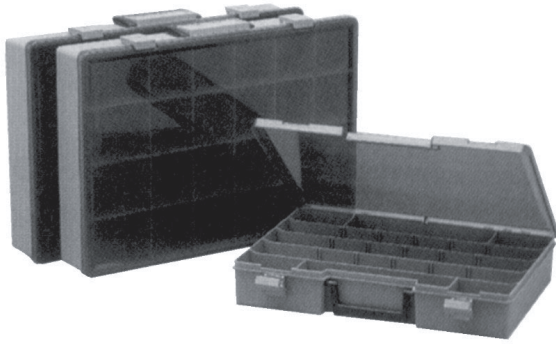

Molded from rugged copolymer resins to meet a variety of storage carrying needs. Used for small parts, tools, sales samples, etc. Take parts directly to work area. Comfortable handle for easy portability. Translucent lids provides visibility and quick identification of contents. Two latches. Fits standard slide racks (98-4LR). Color: gray.

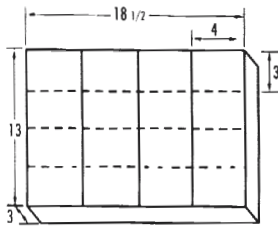

98-1016

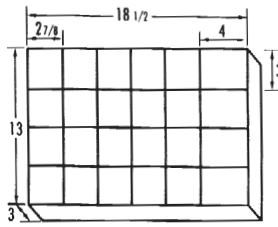

98-1024

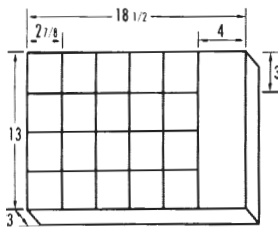

98-1021

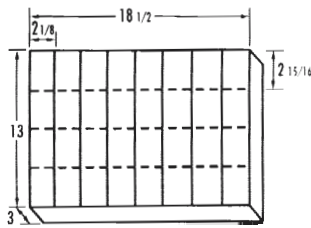

98-1032

Part No.	No. of Compts.	No. of Moveable Dividers	Pkg Qty
98-1016*	4-16	12	6
98-1021	21	-	6
98-1024	24	-	6
98-1032*	8-32	24	6

\* Adjustable layout



## POLYPROPYLENE STORAGE BOX

Unbreakable plastic box with large capacity. 18 compartments. Outside dimensions: 13"W x 8-3/4"D x 2-1/4"H. Color: yellow. Pkg: 1 each. Part No. 13-999

# Stackable Plastic Bins

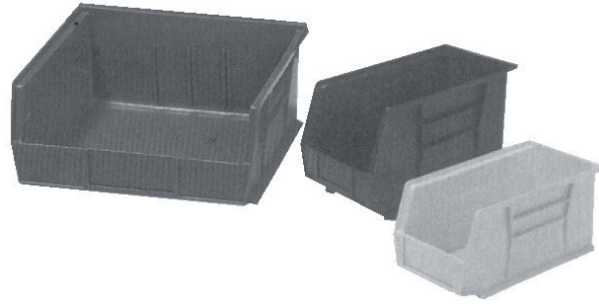

These heavy duty, unbreakable stacking bins are waterproof, oil and chemical resistant. Can be taken directly to work areas for assembly operations. Molded slots for ID labels. Reinforcement ribs. Curved scoop bottom. Color: blue.

Part No.	Outside Dimensions			Pkg Qty
	Length	Width	Height	
98-001	5 3/8"	4 1/8"	3"	24
98-002	7 3/8"	4 1/8"	3"	24
98-003	10 7/8"	5 1/2"	5"	12
98-004	10 7/8"	11"	5"	6
98-005	14 3/4"	8 1/4"	7"	12
98-006	14 3/4"	16"	7"	6

# Corrugated Bins

Store and locate parts fast and efficiently. Carry parts directly to work area. Reduce and control inventories, shorten assembly time and minimize parts handling.

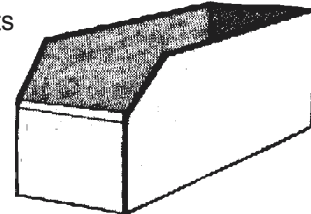

Rugged 200 pound test corrugated fiberboard bins offer exceptional strength and durability. May be placed back-to-back to fit 24" or 36" wide shelving. White on one side only. Shipped flat. Easy to assemble.

Part No.	Outside Dimensions			Pkg Qty
	Length	Width	Height	
98-007	12"	2"	4 1/2"	100
98-009	12"	4"	4 1/2"	100
98-013	12"	6"	4 1/2"	100
98-015	12"	8"	4 1/2"	100
98-011	12"	10"	4 1/2"	100
(98-011 accommodates 8 1/2" x 11" literature, forms, etc.)				
98-012	18"	4"	4 1/2"	100

# Clear Styrene Boxes

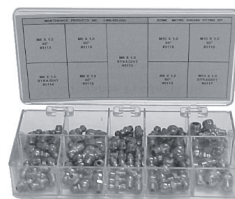
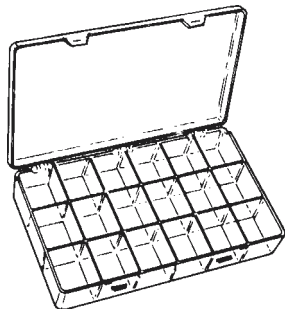

**Great for small parts storage!**

Convenient and inexpensive! Protects small components, precision parts, electronic parts, hardware, office supplies, pins, needles, small tools, labels, sportsmens accessories, precision parts. Molded polystyrene construction. Permanently molded-in compartments. Made in U.S.A.

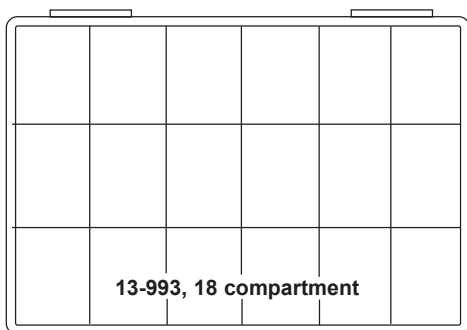

**13-993, 18 compartment**

*Outside dimensions:  
8-1/2"W x 4-1/2"D x 1-3/8"H*

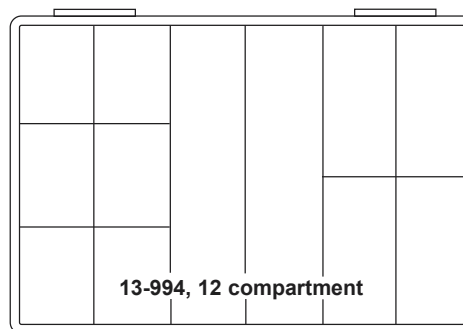

**13-994, 12 compartment**

*Outside dimensions:  
8-1/2"W x 4-1/2"D x 1-3/8"H*

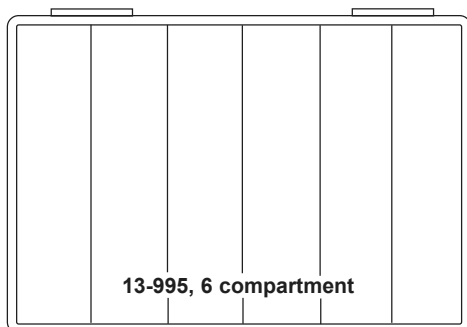

**13-995, 6 compartment**

*Outside dimensions:  
8-1/2"W x 4-1/2"D x 1-3/8"H*

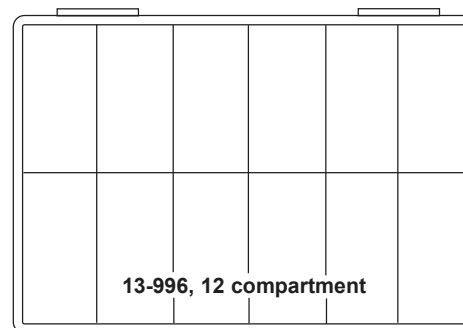

**13-996, 12 compartment**

*Outside dimensions:  
8-1/2"W x 4-1/2"D x 1-3/8"H*

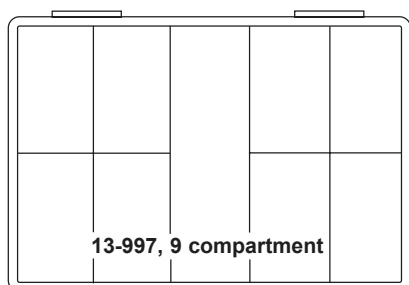

**13-997, 9 compartment**

*Outside dimensions:  
7"W x 3-3/4"D x 1-1/4"H*

VISIT OUR WEBSITE  
**mpi-online.com**  
FAX ANYTIME!  
**219-696-6413**



# "Customized" Assortments

Can't find the right assortment? Your MPI representative can help you design a custom assortment to fits your needs!

MAINTENANCE PRODUCTS, INC. CUSTOM ASST			Customer If a non stock item, please include full description		
PART NO	PART NO	PART NO	PART NO	PART NO	PART NO
QTY	QTY	QTY	QTY	QTY	QTY
DESC.(n/a only)	DESC.(n/a only)	DESC.(n/a only)	DESC.(n/a only)	DESC.(n/a only)	DESC.(n/a only)
PART NO	PART NO	PART NO	PART NO	PART NO	PART NO
QTY	QTY	QTY	QTY	QTY	QTY
DESC.(n/a only)	DESC.(n/a only)	DESC.(n/a only)	DESC.(n/a only)	DESC.(n/a only)	DESC.(n/a only)
PART NO	PART NO	PART NO	PART NO	PART NO	PART NO
QTY	QTY	QTY	QTY	QTY	QTY
DESC.(n/a only)	DESC.(n/a only)	DESC.(n/a only)	DESC.(n/a only)	DESC.(n/a only)	DESC.(n/a only)
PART NO	PART NO	PART NO	PART NO	PART NO	PART NO
QTY	QTY	QTY	QTY	QTY	QTY
DESC.(n/a only)	DESC.(n/a only)	DESC.(n/a only)	DESC.(n/a only)	DESC.(n/a only)	DESC.(n/a only)

Drawer Planograph

MAINTENANCE PRODUCTS, INC.							
Customer Name		CUSTOMIZED ASSORTMENT					
Control number							
Always put down part number and quantity for each item Attach completed planograph to original order.							
Reorder Numbers: Planograph--72							
PART #	PART #	PART #	PART #	PART #	PART #	PART #	PART #
SIZE	SIZE	SIZE	SIZE	SIZE	SIZE	SIZE	SIZE
DESC.	DESC.	DESC.	DESC.	DESC.	DESC.	DESC.	DESC.
QTY	QTY	QTY	QTY	QTY	QTY	QTY	QTY
PART #	PART #	PART #	PART #	PART #	PART #	PART #	PART #
SIZE	SIZE	SIZE	SIZE	SIZE	SIZE	SIZE	SIZE
DESC.	DESC.	DESC.	DESC.	DESC.	DESC.	DESC.	DESC.
QTY	QTY	QTY	QTY	QTY	QTY	QTY	QTY
PART #	PART #	PART #	PART #	PART #	PART #	PART #	PART #
SIZE	SIZE	SIZE	SIZE	SIZE	SIZE	SIZE	SIZE
DESC.	DESC.	DESC.	DESC.	DESC.	DESC.	DESC.	DESC.
QTY	QTY	QTY	QTY	QTY	QTY	QTY	QTY
PART #	PART #	PART #	PART #	PART #	PART #	PART #	PART #
SIZE	SIZE	SIZE	SIZE	SIZE	SIZE	SIZE	SIZE
DESC.	DESC.	DESC.	DESC.	DESC.	DESC.	DESC.	DESC.
QTY	QTY	QTY	QTY	QTY	QTY	QTY	QTY
PART #	PART #	PART #	PART #	PART #	PART #	PART #	PART #
SIZE	SIZE	SIZE	SIZE	SIZE	SIZE	SIZE	SIZE
DESC.	DESC.	DESC.	DESC.	DESC.	DESC.	DESC.	DESC.
QTY	QTY	QTY	QTY	QTY	QTY	QTY	QTY
PART #	PART #	PART #	PART #	PART #	PART #	PART #	PART #
SIZE	SIZE	SIZE	SIZE	SIZE	SIZE	SIZE	SIZE
DESC.	DESC.	DESC.	DESC.	DESC.	DESC.	DESC.	DESC.
QTY	QTY	QTY	QTY	QTY	QTY	QTY	QTY

Bin Planograph

# Assortment Labels

Reorganizing your stock room? Replacement bin labels are available for any assortment in our line at no charge to you.

16-3724 REVISED 2/89		MPI Wire Terminals - Nylon Insulated with insulation grip									
# 02-178 16-14 WIRE FLAG Q.S. FULLY INSULATED 1/4 TAB	# 02-073 18-14 WIRE T-TAP accepts 1/4" Male tabs	# 02-106 12-10 WIRE MALE Q.S. FULLY INSULATED 1/4 TAB	# 02-107 12-10 WIRE FEMALE Q.S. FULLY INSULATED 1/4 TAB	# 02-019 22-18 WIRE MALE Q.S. FULLY INSULATED 1/4 TAB	# 02-020 22-18 WIRE FEMALE Q.S. FULLY INSULATED 1/4 TAB	# 02-022 22-18 WIRE BUTT CONNECTOR	# 02-001 22-18 WIRE 4-6 STUD RING	# 02-002 22-18 WIRE 8-10 STUD RING	# 02-009 22-18 WIRE 8-10 STUD SPADE (FORK)	# 02-060 16-14 WIRE MALE Q.S. FULLY INSULATED 1/4 TAB	# 02-061 16-14 WIRE FEMALE Q.S. FULLY INSULATED 1/4 TAB
# 02-072 16-14 WIRE BUTT CONNECTOR	# 02-040 16-14 WIRE 4-6 STUD RING	# 02-041 16-14 WIRE 8-10 STUD RING	# 02-042 16-14 WIRE 12-1/4 STUD RING	# 02-047 16-14 WIRE 4-6 STUD SPADE (FORK)	# 02-048 16-14 WIRE 8-10 STUD SPADE (FORK)	# 02-113 12-10 WIRE BUTT CONNECTOR	# 02-091 12-10 WIRE 8-10 STUD RING	# 02-092 12-10 WIRE 12-1/4 STUD RING	# 02-094 12-10 WIRE 3/8 STUD RING	# 02-098 12-10 WIRE 8-10 STUD SPADE (FORK)	# 02-151 14-18 WIRE INLINE CONN

Lid charts



Drawer front labels

1/4 LOCK WASHER #01-1010 Pkg 100 MPI 800-523-2367...Reorder at 25, Order Qty 100
5/16 LOCK WASHER #01-1020 Pkg 100 MPI 800-523-2367...Reorder at 25, Order Qty 100
3/8 LOCK WASHER #01-1030 Pkg 100 MPI 800-523-2367...Reorder at 25, Order Qty 100
7/16 LOCK WASHER #01-1040 Pkg 100 MPI 800-523-2367...Reorder at 25, Order Qty 100
1/2 LOCK WASHER #01-1050 Pkg 100 MPI 800-523-2367...Reorder at 25, Order Qty 100
9/16 LOCK WASHER #01-1060 Pkg 50 MPI 800-523-2367...Reorder at 13, Order Qty 50
5/8 LOCK WASHER #01-1070 Pkg 50 MPI 800-523-2367...Reorder at 13, Order Qty 50
3/4 LOCK WASHER #01-1080 Pkg 25 MPI 800-523-2367...Reorder at 6, Order Qty 25

Bin and cabinet labels

# Rate Your Current Hardware Supplier

## SERVICE

- Regular service calls, month-in and month-out? **Free!**
- Sort and maintain bins with easy to read labels? **Free!**
- Fast service on special orders?
- Instant stock checks by phone?
- Instant order status inquiries by phone?
- Instant access to your own purchase history?
- Toll **Free!** phone number?
- Annual reports showing all your purchases? **Free!**
- Same day shipping on orders called in by 2:00 P.M. CST?

## PRODUCTS

- Made in the U.S.A.?
- Brand name products you can trust?
- M.S.D.S.. For O.S.H.A. compliance? **Free!**
- Free!** certifications?
- ISO 9000 manufacturers?
- New products introduced regularly?
- 97% fill rate?
- Special ordered parts?
- Special stocking arrangements to suit your needs?

## PRICES AND CATALOGS

- No "low-ball" prices just to get your business?
- Prices are consistent order after order, no surprises six months later?
- Prices are as quoted?
- Price lists on computer disk? **Free!**
- Price lists on paper? **Free!**
- Catalogs? **Free!**
- Free!** Freight on orders over \$300?

## RETURNS AND CREDITS?

- Handled promptly and at no charge?
- Few and far between, orders double checked for accuracy?
- Replacements made quickly and accurately?



**CAN! NUFF SAID!**

(And besides, we have nicer sales people!)





# Maintenance Products Inc.

797 W. Commercial Ave. • PO Box 368 • Lowell, IN 46356-0368  
(800)523-2367 • (219)696-6411 • FAX (219)696-6413

## CREDIT APPLICATION

Company Name \_\_\_\_\_

Mailing Address \_\_\_\_\_

City \_\_\_\_\_ State \_\_\_\_\_ Zip Code \_\_\_\_\_

Ship to Address (if different) \_\_\_\_\_

City \_\_\_\_\_ State \_\_\_\_\_ Zip Code \_\_\_\_\_

Phones

Purchasing \_\_\_\_\_ Shop \_\_\_\_\_ Accounts Payable \_\_\_\_\_

Fax \_\_\_\_\_  Corporation  Proprietorship  Partnership

Owner or President \_\_\_\_\_ Title \_\_\_\_\_

Social Security or Federal ID Number \_\_\_\_\_

Years in Business \_\_\_\_\_ Nature of Business \_\_\_\_\_

Bank Name \_\_\_\_\_ Checking Account Number \_\_\_\_\_

Address \_\_\_\_\_

If you are tax exempt, please attach a signed sales tax exemption certificate.

### CREDIT REFERENCES

We need three current sources of supply with whom you do business with on an open, 30 day account.

Please do not use banks, credit card companies or secured loans as references.

Name	Address	Phone	Acct #
1. _____	_____	_____	_____
2. _____	_____	_____	_____
3. _____	_____	_____	_____

Terms of payment are net 30 days. Past due invoices are subject to a 1-1/2% monthly service charge. Credit privileges are revoked if consistently past due. Minimum invoice charge is \$10.00. Cost of collecting money due and owing on this account, including court and attorney fees, will be charged to the debtor. In making this application, the customer agrees to these terms.

Signature \_\_\_\_\_ Title \_\_\_\_\_ Date \_\_\_\_\_

CUT ALONG DOTTED LINE