

Small Parcel Shipping within the Continental U.S.

Use the shipping schedule to determine your charges for small parcel surface shipping in the continental United States. Air shipping is available at extra cost. All carriers use dimensional weight to assess air shipping charges.

Minimum order amount is \$25.00. With the rising costs of supplies, credit card processing and administrative fees, orders under 25.00 are not financially feasible to process in any practical manner.

Small Parcel Shipping to Alaska, Hawaii, and Foreign Countries including Canada:

Since the Post Office, Federal Express, and other small package carriers have instituted dimensional weight, the charges for packages vary widely. Estimates are 25% of parts cost. We have had several lost parcels using the postal service and recommend FedEx as the best delivery company for non-continental U.S. addresses. Large parcel orders are shipped via air freight. Contact us with the details of your order and we will quote the charges.

Back Orders: Although we have a large inventory of parts available, occasionally back orders occur. Regular inventory items not in stock at the time of your order will be shipped at no additional cost, as quickly as possible.

Damaged Merchandise: Contact us immediately if you have a damaged parcel. Do not discard any packing as you may harm your chances of quick resolution. Have your invoice number ready when calling.

Returns: Must be accompanied by copy of invoice and returned in the same condition as shipped.

All returns are subject to a 15% inspection and restocking assessment.

Warranty: Items we manufacture carry a limited lifetime warranty. Items we do not manufacture carry a warranty of one year from the date of purchase. Warranty is limited to the replacement of parts. Proof of purchase required.

Price Changes: We will notify you of any substantial price changes before shipping. Items with small increases will be processed and the amount due will be billed to your account or added to your invoice. If you are billed, please pay the balance due upon receipt. Prices are subject to change without notice.

Payment: Because of increasing amount of incomplete transactions, we are no longer accepting COD orders. Please mail check or money order payable to: Fusick Automotive Products, Inc. We reserve the right to hold personal checks up to 14 days for bank clearance.

Credit Cards: We accept Visa, MasterCard, American Express and Discover Card as payment. FAX, mail or Email orders are preferred to avoid delays due to incorrect or incomplete information.



Shipping: Orders are processed within 2 hours of receipt and are shipped the same day whenever possible. Please provide a street as well as mail address to assist us in handling your order quickly. Please print or type your order.

Show Schedule: It is impossible to have every item in our inventory available off premises. However we do try to have a large selection of popular items available. If you plan on attending one of the shows and would like us to deliver parts to you please contact us 2 weeks prior to the show. We will have the parts set aside for you.

Uncommon color interior items or special order items will need even more time.

- | | | |
|---|--------------------------|---------------------|
| 1. Spring Carlisle, Penn. | Spaces N160-65 | April 23-27, 2008 |
| 2. Long Island Oldsmobile Club Spring Dustoff | Merrick, Long Island, NY | First Sunday in May |
| 3. Oldsmobile Club of America National Meet | Dearborn, MI | August 6-9, 2008 |
| | Pittsburgh, PA | July 15-19, 2009 |
| 4. Fall Carlisle, Penn. (Infield) | Spaces IJ33-39 | October 3-7, 2007 |
| 5. Fall Hershey, Penn. (Green Field) | Spaces GBJ 1-5 | October 10-13, 2007 |



Fusick

Automotive Products Inc.

PO Box 655, 22 Thompson Road
East Windsor, CT 06088-0655

FAX MACHINE
1-860-623-3118

Email: fusickauto@aol.com

Website: www.fusick.com



1-860-623-1589

1-860-623-1583

M-TH 8:00 AM to 6:00 PM

FRI 8:00 AM to 5:00 PM

SAT 9:00 AM to NOON



Welcome "Early Olds" Enthusiasts,

This is our 37th year of serving the Oldsmobile enthusiast. We constantly strive to bring you the hard to find parts you need to restore your Oldsmobile. Fusick Automotive Products, Inc. has over 1000 tools we use to bring non-existent parts back to the market place. We want you, the Oldsmobile enthusiast, to have as many parts available as other popular makes. Over 97% of orders are shipped within 24 hours of receipt and are filled complete.

Popular New Old Stock has become nearly extinct while tooling and production costs have continued to rise. Some reproduction parts have taken years to sell their initial amount so a second production run has become unlikely. Additionally, several tools have become obsolete with new technology machinery. Check the parts that are destined for discontinuation to see if you have any future need. We dislike the idea of removing any pre 1961 Oldsmobile parts from the catalog, but unfortunately it has become an economic reality.

Please read our policies and procedures on the opposite page before ordering. Remember, we consistently maintain a large inventory of parts in order to offer same day shipping. We appreciate your mail-in, e-mail, or fax order to help eliminate needless communication errors. Enjoy the catalog and we look forward to assisting with your Oldsmobile restoration in the near future.

For those of you who are restoring or own more than one Oldsmobile, we have catalog 40C for 1961-77 Cutlass-442-Hurst/Olds, and Catalog 18BC for 1961-75 88-98-Starfire-Tornado owners. As always, catalogs are free with an order.

Sincerely for Oldsmobile,

Office Personnel

David Jackson

Jason Jutras

Kevin McMahon

Stephen O'Brien

Warehouse Personnel

James Hemingway

Terrance Chase

Michael Fusick

Member:

Oldsmobile Club of America (#43)

National Antique Oldsmobile Club (#15)

Antique Automobile Club of America (303935J)

Serving Oldsmobile Enthusiasts Since 1971

WHEEL COVERS

All of the wheel covers on this page are in danger of discontinuation. Manufacturer indifference, unreliable antiquated tooling, and slow sales have all contributed to their demise. If you see a future need do not wait. The 1956 Deluxe Spinner Wheel covers have been discontinued.

1939-42 Hub Caps: Brilliant chrome finish with red ring and crest. Fits 1939-42 16 inch rims ONLY and measures 9 3/8" in diameter. Superior quality and workmanship. Original part number is 916490. These have been discontinued by our supplier and only 20 sets remain in stock at catalog printing.

HC250 1939-42 Hub Cap (four) 190.00 set **HC250A** Hub Cap (one) 50.00 ea.



Wheel Trim Rings: For all 1934-53 15 or 16 inch wheel rims with small hub caps. 1949-53 Models originally used a 3 rib trim ring. The 15 inch trim ring we offer is a single rib design. Although not correct, the single rib does have an excellent appearance. Highly polished stainless steel. Sold individually.

WTR15 Wheel Trim Ring 15 inch wheel 1940 90, 1941-53 All 31.50 ea.
WTR16 Wheel Trim Ring 16 inch wheel 1934-48 All 31.50 ea.

1953 Fiesta, 1954-55 All Deluxe Spinner Wheel Covers:

Probably the most sought after Oldsmobile Wheel Cover. Constructed in stainless steel with a hard chrome surface as original to resist scratches. The Wheel Cover features correct painted white rings, center medallion, and three flipper ornaments. For 15" wheels only.

HC400 Spinner Wheel Cover 1953 Fiesta, 1954-55 All Discontinued
HC400A Spinner Wheel Cover 1953 Fiesta, 1954-55 All Discontinued



1957 All Deluxe Spinner Wheel Cover: The 1957 Spinners are a two piece stainless steel construction and finished with hard chrome like the originals. Much time and expense was dedicated to make a superior Wheel Cover. Retaining clips are NOT included with the Wheel Covers, see below. For 14" wheels only. This will be the final run on the 1957 wheel covers.

HC500 Spinner Wheel Cover 1957 All 395.00 set
HC500A Spinner Wheel Cover 1957 All 110.00 ea.



Deluxe Wheel Cover Retaining Clips: For installation on all 1957-60 and 1962-63 Oldsmobiles with Deluxe Wheel Covers. Uses 5 clips per wheel.

578143 Wheel Cover Clips 6.00 ea.



1941-58 Small Hub Cap Retaining Clip: These clips are missing on wheels that used full disc wheel covers. Clip fastens to three slotted holes in rim. 3 clips used per wheel.

564692 Retaining Clip 1941-58 All 4.50 ea.



Tire Valve Stems: For use on tubeless design rims. Correct sizes for 1941-60 Oldsmobile.

10204 Valve Stem 1941-56 All 6.50 ea.
10192 Valve Stem 1957-60 All 6.50 ea.

INSIDE AND OUTSIDE REAR VIEW MIRRORS



397IM Inside Rear View Mirror (not non-glare) 1939-47 Most Models. 39.50



480IM Inside Rear View Mirror using threaded type mounting bracket. 1948-50 Some Models using 1 piece windshield. Non-glare. 79.50



480IMS Inside Rear View Mirror using loop bracket and set screw. 1950-53 Models using 1 piece windshield. Non-glare. Check usage carefully. 79.50

546IMS Day/Night Inside Rear View Mirror (non-glare), fits 1954-56 all models. 79.50

549IMS Day/Night Inside Rear View Mirror (non-glare), fits 1957-60 all models. 79.50



IMS522 Inside Mirror to Bracket Chrome Set Screw 1952-60 All 3.50



328L 1932-38 Left Outside Chrome Side View Mirror. Fits all closed Models. Package includes gasket and mounting screws. 64.50



540B 1954-56 Outside Chrome Side View Mirror. Fits all models on both right and left side. Screws, mounting bracket and rubber gasket included. (3 1/4" x 1 3/16") 84.50 each



378L 1939-50 Left Outside Chrome Side View Mirror. Used on all closed Models except 1949 76 & 88 series. Gasket and screws included. (3 3/16" x 5/8") 84.50



570B 1957-58 All Models Outside Chrome Side View Mirrors. Fits left and right side of car. Screws, mounting bracket and rubber gasket included. (4 11/16" x 1 1/8") 84.50 each



490L/R 1941-48 Convertible, 1940-48 Station Wagons Outside Chrome Side View Mirrors. Screws included. Specify Left or Right side. (2 5/8" x 11/16") 84.50 each



590B 1959-60 Outside Chrome Side View Mirrors. Fits all models on right and left side of car. Mounting bracket, gasket and screws included. (4 3/16" x 3/4") 84.50 each



483L/R 1949-50 Outside Chrome Side View Mirrors. Fits all 1949-50 Holiday Coupes and Convertibles. Screws included. Specify Left or Right side. (2 5/8" x 11/16") 84.50 each

982178 Visor Vanity Mirror:

Fashionable accessory used on either visor for all 1936-1960 models. Oldsmobile logo in center and areas for maintenance reminders such as mileage, tune-up, oil change, lubrication, spark plugs, etc. Licensed and approved by General Motors. 38.00



513L/R 1951-53 All Models Outside Chrome Side View Mirrors. Screws, Mounting Bracket and rubber gasket included. Specify Right or Left side. (3 1/8" x 1 1/4") 84.50 each



Accessory Traffic Light Viewer:

Brings traffic lights into view even on cars with accessory visors. A highly sought after accessory for all 1949-56 models.

TLV496 Traffic Light Viewer 49.50

Special Note on Mirrors: The mirrors we have manufactured are exact copies of original mirrors supplied by General Motors. Please note the measurement provided for the base. There were several different manufacturers of aftermarket mirrors that could have been installed on your car over the years. These mirrors differ from the correct mirrors we offer.

PARK AND BACK-UP LIGHT LENSES

Park Light Lenses



1949-50 All, 1951 88A and 51 98 Park Light Lens: Lens is molded with the correct Guide F-39 and 5938319 part number.

5938319 Park Light Lens 21.50 ea.
PLG49 Park Light Lens Gasket 3.75 ea.

1951-52 88-Super 88 Park Light Lens: Lens is molded with the correct Guide F3-51.



5940023 Park Light Lens 21.50 ea.



1953 88-S88-98 Park Light Lens: Molded with Guide F3-53 and 5944027 part number.

5944027 Park Lens 21.50 ea.
PLG53 Park Lens Gasket 3.75 ea.

1954 All Models Park Light Lens: Lens has Guide F3-54 and 5941748 molded in plastic as original.



5941748 Park Light Lens 26.50 ea.
PLG54 Park Lens Gasket 3.75 ea.
PLG54B Park Light Assembly to fender mounting gasket 3.75 ea.



1955 All Models Parking Light Lens: Guide F3-55 and 5945728 molded in lens as original.

5945728 Park Light Lens 26.50 ea.
PLG55 Park Lens Gasket 3.75 ea.

1956 All Models Park Light Lens: Lens has Guide F3-56 and 5947087 molded in plastic as original.



5947087 Parking Light Lens 26.50 ea.
PLG56 Parking Lens Gasket 3.75 ea.



1957 All Models Parking Light Lens and Chrome Ornament: Guide F3-57 is molded in lens as original. Chrome ornament (bullet) sold separately.

5948507 Park Lens 26.50 ea.

PLO57 Chrome Ornament 12.50 ea.
PLG57 Park Lens Gasket 3.75 ea.

1958 All Models Park Light Lens: Lens has Guide F3-58 molded in the plastic as original.

5949175 Park Light Lens 37.50 ea.
PLG58 Park Lens Gasket 4.75 ea.



1959 All Models Park Light Lens: Part number 5949997 is molded in plastic lens as original.

5949997 1959 All Park Lens 29.50 ea.



License and Back-Up Lenses



1955-58 License Lamp Lens: Molded with Guide L-3-55 and 5945916 as original.

5945916 License Lens 19.50
LLG558 Lens Gasket 2.75

1952-56 Models used glass back-up lenses. Glass back-up lenses have been more and more difficult to obtain, however we do have the gaskets available for those models.

BUG525 1952 98, 1953-55 All Back-up Lens Gasket. 3.75 ea.

BU56A 1956 All Back-up Assembly to Body Gasket. 4.50 ea.

BUG56 1956 All Back-up Lens Gasket 4.50 ea.



1957 All Models Back-up Light Lens: Lens has Guide B3-57 and part number 5949582 molded as original.

5949582 1957 All Back-up Lens 24.50 ea.
BUG57 1957 Back-up Lens Gasket 3.75 ea.

1958 88 Back-up Light Lens:

Tear drop shape back up lens used on 88 Models only. Lens has Guide R8B-58 and number 5949006 molded in plastic. Silver painted highlights as original.

5949006 Back-up Lens 34.50 ea.
BUG58 Lens Gasket 5.50 ea.



TAIL LIGHT LENSES



1949 All, 1950 76-88, 1951 88A Tail Light Lenses: Red Lens is molded with Guide R38B and 5938589 in the plastic as original. Early 1949 models used glass lenses. Plastic lenses replace glass lenses and are correct.

5938589 Tail Lens 26.50 ea.
TLG49 Lens Gasket 11.50 ea.

1948-52 Tail Light Reflex Lens:

Correct red reflex lens is metal backed as original. This is the small round reflector under tail light.

5937280 Reflex Lens 16.50 ea.

1948 All, 1949-50 76-88, 1951 88A

5937790 Reflex Lens 11.50 ea.

1950-51 98, 51-52 Super 88 (no metal backing)



1951 Super 88, 1952 88-Super 88 Tail Light Lens: Lens has Guide R3-51 molded in red plastic as original.

5940051 Tail Lens 38.00 ea.

1952-53 98 and Fiesta Tail

Light Lens: Guide R3-52 is molded in red lens as original.

5942900 Tail Lens 38.00 ea.

TLG523 Lens Gasket 3.75 ea.



1953 88 and Super 88 Tail Light Lens: Red lens has Guide R3-53 and 5943993 molded in plastic.

5943993 Tail Lens 38.00 ea.

1954 98 Tail Light Lens:

Guide R3-54 and 5941624 are molded in the red plastic.

5942096 Tail Lens 42.00 ea.

TLG54C Lens Gasket 4.50 ea.



1954 88 and Super 88 Tail Light Lens: Molded in the red plastic are Guide R3A-54 and 5942489 as original.

5942398 Tail Lens 42.00 ea.

TLG54B Lens Gasket 4.50 ea.

1955 98 Tail Light Lens: Red lens has Guide R3A-55 and 5945936 molded in the plastic. Lens also includes the chrome medallions.

5947031 Tail Lens 74.50 ea.

TLG55 Lens Gasket 4.50 ea.

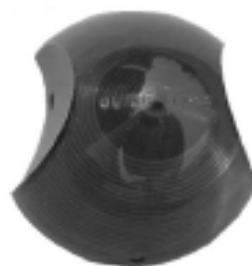

1955 88 and Super 88 Tail Light

Lens: Red lens has Guide R3-55 and 5945941 molded in lens as original.

5945797 Tail Lens 38.00 ea.

TLG55 Lens Gasket 4.50 ea.

1956 98 Tail Light Lens: Red tail lens has Guide R3A-56 and 5946826 molded in plastic as original. Lens includes center chrome molding.

5946758 Tail Light Lens 79.50 ea.

TLG56C Lens Gasket 4.50 ea.



1956 88 and Super 88 Tail Light Lens: Guide R3-56 and 5946756 are molded in the red plastic as the originals.

5946756 Tail lens 45.00 ea.

TLA56B Tail light to body gasket 4.50 ea.

TLG56 Lens gasket 4.50 ea.

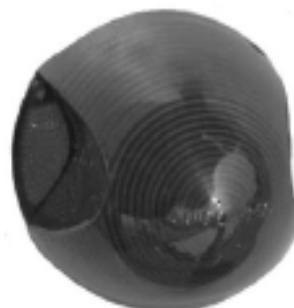

1957 Super 88-98 Tail Light Lens:

Guide R3-57 and 5947890 is molded in red lens as original.

Chrome ornaments available, not included with lenses.

5947890 Tail Light Lens 29.50 ea.

5947891 Lens Ornament 42.00 ea.

TLG57 Lens Gasket 4.50 ea.



1958 88-S88-98 Upper Round Tail Light Lens:

Lens fits all 1958 models. Guide R3A-58 and 5949573 molded in red plastic.

5949573 Upper Lens 48.00 ea.

TLG58U Lens Gasket 5.50 ea.



1958-S88-98 Lower Tear Drop Tail

Light Lens: Lens has Guide R3B-58 and 5949089 molded in red plastic with silver paint accent as original.

5949089 Lower Tail Lens 38.00 ea.

BUG58 Lens Gasket 5.50 ea.



HOOD AND TRUNK EMBLEM INSERTS

Hood and Trunk Plastic Inserts: One of the impossible to repair areas for 1940's and 1950's Oldsmobiles are the hood and trunk plastic inserts.



1948 Deluxe Red Hood Lucite Insert: This hand crafted insert measures 3 1/2" X 3 1/2". Only 5 remain in stock at catalog printing.
554762 Red Insert 1948 all 79.50

1947-49 Hydra-Matic Drive Trunk Inserts



1947 All, 1948 except 98, 1949 Wagon, 1950 Deluxe Wagon Hydra-Matic Drive Plastic Trunk Emblem Insert. This insert fits the trunk emblem on all 1947 models, all 1948 models except 98, all 1949 Station Wagons, 1950 Deluxe Wagon. Red background with silver letters like original, measuring 5 3/8" X 1 3/4".
419657 Hydra-Matic Trunk Insert 49.50



1948 98, 1949 All with Hydra-Matic Transmission Plastic Trunk Emblem Insert. Insert is red background with silver "Hydra-Matic Drive" molded in plastic. Fits 1948 98s and all 1949s except wagons.
554838 Trunk Emblem Plastic Insert 32.50

1952 98 Trunk, 1953 all Hood and Trunk Plastic Inserts: 5" diameter. Silver with black background and silver continents. Plastic inserts fit 1952 98 Trunk, and 1953 Hood and Trunk.

562835 Trunk Emblem Insert 37.50
 1952 98, 1953 All exc. Fiesta

562789 Hood Emblem Insert 35.00
 1953 All models exc. Fiesta



1953 Fiesta, 1954 All models Hood Emblem Plastic Insert: 4 1/2" diameter clear plastic with silver continents. Fits 1953 Fiesta and all 1954 models.



563869 Hood Emblem Insert 35.00



1955 Oldsmobile Hood and Trunk Emblem Plastic Inserts: Hood and Trunk Emblem Inserts are 4 1/2" in diameter. Clear plastic over silver continents with black background.



566324 Hood Emblem Insert 35.00
 1955 All
566325 Trunk Emblem Insert 37.50
 1955 98 Only

1956 Hood Emblem Plastic and Metal Insert (2 pc.): New metal insert with gold stars on a silver background. 4 5/8" diameter, plastic cover sold separately.



567449 Clear plastic cover 1956 All 24.00
567450 Metal star section 1956 All 35.00



1957 Oldsmobile Hood and Trunk Plastic Inserts: Hood and Trunk Inserts are 8 1/2" oval shape with gold stars and silver background. Trunk insert has hole for trunk lock.

569248 1957 All models Hood Insert 32.50
569060 1957 88-S88 Trunk Insert 35.00

1958 Oldsmobile Plastic Trunk Handle Inserts: 1 3/4" diameter red, white, and silver trunk handle insert fits all 1958 Models. 2 used per car.



572551 Trunk handle insert 24.50 ea.

SCRIPTS AND EMBLEMS

We have reproduced the following scripts and emblems as per original. Platers can only make an attempt to correctly restore these parts. Your satisfaction is absolutely guaranteed. All Oldsmobile Scripts and Emblems are reproduced under license to General Motors. * Please note we have marked a few of the emblems as FINAL RUN, which means we will not run any more when supply is out. Keep this in mind if there are any emblems that will be needed in the future.

1940-41 'Olds Hydramatic' Front Fender Script:

One piece script fits all 1940-41 Oldsmobiles equipped with Hydramatic Transmission. Includes fasteners. Two used per car.

415488 'Olds Hydramatic' Script 35.00 ea. *FINAL RUN



1941 'Oldsmobile' Trunk Script: Correct block letter script with excellent chrome finish per original. Fits all 1941 models. Includes fasteners

414235 'Oldsmobile' Trunk Script 32.00 *FINAL RUN



1948-49 'Oldsmobile' Hood and Trunk Letters: Individual letters used on the hood and trunk of all 1948-49 models. Very nice detail and finish. Fasteners included. Two sets per car.

553984 'O-L-D-S-M-O-B-I-L-E' Letter set 38.00 set



1949-1954 '88' Numerals: Individual '8' numerals used on 1949 88s, 1950 88 Station Wagons, 1951-53 all Super 88s & 88s, and on 1954 88 models. Mounts on rear door on four doors and rear fender on two door models. White painted highlights with chrome edges.

Sold in sets of four 8s. Fasteners included.

557230/31 '88' Numerals 45.00 set



1950 'Oldsmobile' Hood and Trunk Letter Set: Individual letter set for the hood and trunk on 1950 Oldsmobiles. Two sets needed except for Station Wagons use one set. Fasteners included.

558182 'O-L-D-S-M-O-B-I-L-E' Letter Set 38.00 set



1952-1953 'Ninety Eight' Script: Correct angle of letters for left and right side of car. Used on rear door or quarter panel on all 1952-53 98 models. One set is four pieces (2-Ninetys, 2-Eights). Only sold in a set. Fasteners Included.

561566/7/8/9 'Ninety Eight' Script set 90.00 set *FINAL RUN



1953 'Oldsmobile' Grille Bar Letter Set: These individual letters fit on the grille bar on all 1953 Oldsmobile models. Correct brushed finish. Fasteners included.

563032/9 'O-L-D-S-M-O-B-I-L-E' Letter set 45.00 set *FINAL RUN



1953 Fiesta, 1957 Fiesta Wagon 'Fiesta' Scripts: Fits on rear quarter for 1953 Fiestas and on the front fender for 1957 Fiesta Station Wagons. Sold in a pair only. Fasteners included.

570248/9 'Fiesta' Scripts 49.00 pr.



1953 'Fiesta' Trunk Script: Fits on the trunk lid on all 1953 Oldsmobile Fiestas. Correct thin script. Fasteners included.

563859 'Fiesta' Trunk Script 37.50



1953-55 'Ninety Eight' Fender and Trunk Script: Fits 1953-55 98s on trunk, and front fenders for 1955 98 4 door sedans. Sold as a pair (one Ninety & one Eight). Two pairs required for fenders, one pair for trunk. Fasteners included.

562793/4 'Ninety Eight' Script 39.50 pr. *FINAL RUN



1954-55 'Holiday' Front Fender Scripts: Script is used on all 1954-55 98 Holiday Coupes and all 1955 Holiday Sedans. Fasteners included.

565050 'Holiday' Fender Script 35.00 ea.



1954-55 98 Convertible 'Starfire' Fender Script: Mounts on front fender on all 1954-55 98 Convertibles. Fasteners included.

565051 'Starfire' Fender Script 35.00 ea.



1955 'Oldsmobile' Grille Letter Set: Individual block stand-up letters that mount on to the grille bar on all 1955 models. Excellent quality chrome with correct ribbed finish. Mounting screws included.

566381/88 'O-L-D-S-M-O-B-I-L-E' Grille letters 95.00 set



1955 98 Convertible Front Fender Star: This star emblem with a circle in the background was used on all 1955 98 convertibles. Two are used per car. Fasteners are included.

566337 Front Fender Star 22.00 ea. *FINAL RUN



1955 Super 88

1955 Super 88 Fender Emblems: Correct round emblem used on all 1955 Super 88s on the lower front fender. Excellent chrome finish with silver painted inside. Fasteners included.

**note: at this time we only have left side available, which can be used on right side with minor modifications.

566642/3 1955 Super 88 Fender Emblems 26.50 ea. *FINAL RUN



1955 88

1955 '88' Front Fender Emblems: Chrome emblems with the correct brushed finish fit on the lower front fenders of all 1955 plain 88s. Sold in a pair. Fasteners included.

566316/7 1955 '88' Fender Emblems 47.50 pr.



1956 Super 88

1956 Super 88 Front Fender Emblems: Two eights over a round background with concentric circles. Beautiful chrome finish with correct black highlights per original. Used on lower front fenders on all 1956 Super 88 models. Sold in a pair. Fasteners included.

567496/7 1956 Super 88 Fender Emblems 53.00 pr.



1956 88

1956 '88' Front Fender Emblems: Fits all 1956 plain 88 models on lower front fender. Two eights connected in the middle with black highlights. Sold in a pair for both sides. Fasteners included.

567536/7 1956 '88' Fender Emblems 47.50 pr.

1956 'Ninety Eight' Trunk & Fender Scripts: Used on all 1956 98s on trunk lid and on 1956 98 4 door sedan front fenders. Sold as a pair (one 'Ninety' one 'Eight'). Fasteners included.

567720/1 1956 'Ninety Eight' Script 39.00 pr.



1956 98 Convertible 'Starfire' Front Fender Letters: Individual letters with excellent chrome finish. Used on front fenders of all 1956 98 convertibles. Two sets needed per car. Fasteners included.
567501/7 1956 'S-T-A-R-F-I-R-E' Letter Set 38.00 set



1956 'Holiday' Front Fender Letters: Individual letter set used on front fenders of all 1956 98 Holiday Coupes (2 dr. hardtop) and all 1956 Holiday Sedan models (4 dr. hardtop). Fasteners included. Two sets per car.
567508/11 1956 'H-O-L-I-D-A-Y' Letter Set 38.00 set



1957 'Oldsmobile' Grille Letter Set: Individual block letter set with excellent chrome finish and correct ribbed face. Fits on grille of all 1957 models. Fasteners included.
570891/98 1957 'O-L-D-S-M-O-B-I-L-E' Grille Letters 95.00 set



1957 'Ninety Eight' Right Fender Scripts: Three piece script set with the Saturn emblem in the middle. Correct angle of the letters for the passenger front fender on all 1957 98s. Fasteners included.
570250/2/4 1957 'Ninety Eight Saturn' Script Set 55.00 set



1957 'Ninety Eight' Left Fender scripts: Three piece script set includes the Saturn emblem. Correct backward angle of the letters for the driver side front fender on all 1957 98s. Fasteners included.
570251/3/5 1957 'Ninety Eight Saturn' script Set 55.00 set



1957 'Ninety Eight' Trunk Script Set: Three piece set includes the Saturn emblem. Used on the trunk lid of all 1957 98s. Letters are angled forwards as original. Includes fasteners.
569083/4/5 1957 'Ninety Eight Saturn' Trunk scripts 89.00 set



1957 '88' Emblem: Chrome emblem is mounted on molding (pass. side) or gas door (driver side) below the tail lights on all 1957 plain 88 models. Correct contour on back to fit snug on molding. Fasteners included. Sold in a pair for both sides of car.
569079 1957 '88' Emblems 49.50 pr.



1957 'Super 88' Front Fender Scripts: Excellent quality chrome script with correct black accents. Fits on front fender for all 1957 Super 88 models. Sold in a pair. Fasteners included.
570292/3 1957 'Super 88' Fender Script 55.00 pr.



1958 'Oldsmobile' Hood Letter Set: Beautiful reproduction of the hood letters that go on all 1958 models. Excellent chrome finish with black highlights in the letters. Sold only in a set. Fasteners are included with hood letter set.
572560/69 1958 'O-L-D-S-M-O-B-I-L-E' Hood Letters 95.00 set



1958 Super 88 and 98 'Oldsmobile' Trunk Letter Set: Same excellent finish as the hood letters above. Fits on trunk lid of 1958 super 88s and 98s. Fasteners are a special design and are not included with letter set, available separately (below).

572462/69 1958 'O-L-D-S-M-O-B-I-L-E' Super 88 & 98 Trunk Letter Set 95.00 set
EF58L 1958 Trunk Letter Fastener Set includes clips and rubber grommets 40.00 set

1958 'Fiesta' Station Wagon Script: Mounted on the rear quarter panel on all 1958 Wagons. Correct script with excellent chrome finish. Two needed per car, fits either side. Fasteners included.

572658 1958 'Fiesta' Script 39.00 ea. *FINAL RUN



1958 Grille Emblem: Beautiful reproduction of a very hard to restore emblem. Excellent chrome finish with correct red and white painted sections. Mounts in the center of the grille on all 1958 models. Mounting studs and fastener. included.

574767 1958 Grille Emblem 49.00
*FINAL RUN



1958 Super 88 and 98 Rear Door or Quarter Emblem: Chrome plated die cast emblem with red and white paint detail as original. Mounts on rear door for 4 door models and rear quarter panel for 2 door models. Fasteners included.

4722817 1958 Super 88 & 98
Rear Emblem 35.00 ea.
*FINAL RUN



1951 Super 88, 1952-53 88 & Super 88 Trunk Rocket: Beautiful chrome finish with black and white highlights per original. Applicable to all 1951 Super 88s and 1952-53 Super 88 and 88 models. Mounts on the driver side trunk lid with the fasteners provided.

560070 '88' Rocket Emblem 72.00



1954-56 Super 88 Trunk Rocket Emblem: Standard on all 1954-1956 Super 88 models. Nice optional addition for plain 88 models. Quality chrome plating with correct white and black highlights where originally used. Fits on drivers side trunk lid with included fasteners.

983176 '88' Rocket Emblem 72.00

1958 All Models Rear Door or Rear Quarter Panel Vertical Cast Molding: This is the vertical molding on all 1958 Oldsmobiles where the four horizontal moldings begin. Excellent quality chrome finish with correct black highlights. Two used per car, same on left or right side. Sold individually, includes fasteners.

4738043 1958 Vertical Quarter Panel or Rear Door Molding 42.00 ea.



1959 Super 88 & 98 Front Fender Chevron Moldings: New reproductions using quality chrome plating with the correct painted black highlights inside moldings. Used on all 1959 Super 88 and Ninety-Eight models. Sold in a set of twelve moldings with correct molding clips included.

578074/5/6/7 1959 Chevron Moldings Coming soon
Mid 2008

INTERIOR APPEARANCE ITEMS

Door Lock Buttons and Plastic Lock Ferrules:

For 1937-58 Models. Plastic ferrules used on most 1953-58. Adds the final touches to your interior restoration.

DB37 Door Lock Button, brown rubber (1 1/4") tall for 1937-48 All exc. 1948 98 5.50 ea.

DB48 Door Lock Button chrome plated (1 3/8" tall) 1948 98, 1949-58 All 12.50 ea.

DLF536 Door Lock Button Ferrule (grey plastic) 1953-56 Super 88-98-Fiesta, H/Coupe & Conv., 1955-56 4 Door Hardtops 4.50 ea.

DLF578 Door Lock Button Ferrule (grey plastic) 1957-58 Super 88-98 Exc. S88 2 & 4 Door Sedans 4.50 ea.



Inside Door-Window-Vent Opening Handles:

Difficult and expensive parts to replate. Usually pitted after many years. Check your car for proper usage and quantities needed.

1949-53, 1959-60 Inside

Door Opening Handle:

Fits all 1949-53, 1959-60 Dynamic 88 Front and Rear Door, except 1950-51 98s. 5 1/2" long, cast chrome plated with fastener clip.

IDH493 Inside Door Opening Handle 24.50 ea.



1954-58 Inside Door

Opening Handle: Fits all 1954-58 Models. 5" length, cast chrome plated with fastener clip.

IDH548 Inside Door Opening Handle 24.50 ea.

1959-60 Inside Door

Opening Handle:

Fits 1959-60 Super 88-98 models. Paddle style, smooth chrome finish.

IHD634 Inside Door Opening Handle 42.50 pr.



1949-58 Window Crank Handle: 5 3/4" long. This handle fits 1949-52 (except 1950-51 98 and 1949-50 Station Wagons), 1953 All, 1954-57 Super 88-98, 1958 Super 88 Wagon. With chrome knob, includes fastener.

IWH497 Window Crank Handle 26.50 ea.



1959-60 Window Crank

Handle: This window crank handle fits 1959-60 All models. 4 1/2" long with chrome knob.

IWH594 Window Crank Handle 26.50 ea.



1949-58 Vent Window Crank

Handle: Fits 1949 98, 1951 Super 88, 1952-57 all (except 1953 Fiesta), 1958 98 (except 4 door sedan), 1958 Super 88

Wagon. 3 1/2" long with chrome knob, includes clip.

IVH498 Vent Window Crank Handle 26.50 ea.



1959-60 Vent Window

Crank Handle: 3 1/2" long with chrome knob, correct ring design. Fits all 1959-60 models.

Includes fastener clip.

IVH594 Vent Window Crank Handle 26.50 ea.



1949-56, & 1959 Outside Door Handles

This is a part constantly ruined by platers because of the detailed design in the handle. **ODH503** fits 1949-50 76-88, 1951 88A all 2 and 4 door models except 1949 Station Wagon front or rear. Also fits 1951 Super 88, 1952-53 88-98-Fiesta

Holiday Coupe and Convertible. You will need to reuse your old lock button and retaining parts. **ODH546** and **ODH59** fit 2 door models only and include buttons. Sold in pairs only. Door handle gaskets sold separately.

ODH503 Door Handles 1949-53 see above 110.00 pr.

ODH546 Door Handles 1954-56 2 Door Holiday Coupe and Convertible 115.00 pr.

ODH59 Door Handles 1959 2 Door 129.00 pr.



1949-53 Convertible Top Chrome Latch Handle:

Nice chrome reproduction of a piece commonly broken or pitted. Handle fit 1949-53 All convertible models. Chrome set screw included with handle.

CTH453 Top Handle 1949-53 All Conv. 59.50

Dome and Courtesy Lenses and Bezels



1934-39 Dome Lens with Stainless Rim: This dome lens with stainless steel rim fits 1934-38 all closed models, 1939 60 series 2 and 4 door sedans. 4 3/8" diameter.

DL348 Dome lens and rim 26.50

1953-60 Accessory Courtesy Lamp Bezel and Lens: 3" long diamond shaped chrome bezel and lens. This assembly fits under the dash on driver and passenger side of cars equipped with the accessory lamp package.



CLB530 Courtesy Lamp Lens and Bezel 33.50 ea.



1939-48 Closed Model Dome Lens:

Dome lens fits 1939-40 70 & 90 Series 2 and 4 door sedans, 1941-48 2 and 4 door sedans.

DL398 Dome Light Lens 22.50 ea.

1949-50 Side roof panel courtesy light lens:

Fits in rear passenger area at bottom of side roof panel for 1949 98 holiday coupes, 1950 76-88 deluxe holiday coupes. Translucent lens measures 3 1/2" x 1 3/4" and has four grooves in lens.

Two lenses used per car.

DL490 Side Courtesy Lens 16.50 ea.

1940-48 Convertible, 1949-50 76-88 Convertible Dome Lens and Chrome Bezel: Translucent lens with chrome bezel.

DL409 Dome Lens and Bezel



37.50



1949-60 Center Roof Mount Dome Lens and Rim:

Center roof mount dome lens measures 4 1/2" X 2" and chrome bezel is 7 1/2" X 2 3/4". This assembly is mounted in the center of the roof on most 1949-60 2 and 4 door sedan models. Opening in bezel for switch.

Check your car for proper application.

DL506 Center Roof Dome Lens 11.50

DL506R Center Roof Dome Lens Bezel 29.50

1954-60 Courtesy Lamp Lens and Chrome Bezel:

Courtesy Lamp Housing at rear arm rest area is show quality chrome. Highly detailed, chrome plated with white painted interior, this housing fits in the rear arm rest area of all 1954-60 Convertibles. Companion lens measures 1 1/2" X 1 1/4" and is sold separately.

CLH622 Convertible Lens Housing 26.50 ea.

CL877 Convertible Courtesy Lens 6.50 ea.



1951-58 Side Roof Courtesy Lens and Rim: Side Roof Lens fits 1951-53 Convertibles and many 1951-58 models. This assembly is mounted above the side windows. Lens measures 3 1/2" X 1 1/2" and the plastic chrome rim measures 5 1/4". Uses 2 per car.

DL505 Side Roof Lens 9.50 ea.

DL505R Chrome Bezel 21.50 ea.



1959-60 Side Roof Dome Light Lens: Fits 1959-60 models except conv. & wagons in roof rail area. Lens measures 6 1/4" long X 1 1/2" wide at widest point. Uses two lenses per car.

DL591 Side Roof Dome Lens 1959-60 16.50 ea.

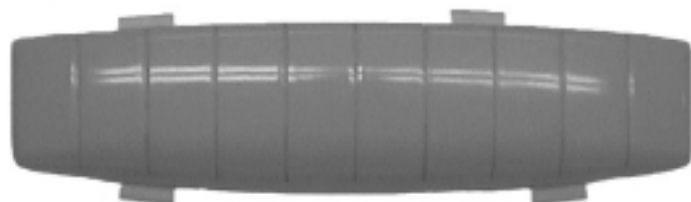



1948-57 Dome Light Switch Cover: Chrome plated stamped steel cover fits dome light switch on 1948-57 all models, and 1958-

59 convertibles only.

DL457 Dome Light Switch Cover 9.50 ea.

1948-58 Dome Light Switch: Fits under the dome light switch cover (above) on 1948-51 all models except 48-49 98 conv., also fits 1952-58 all models with two roof rail dome lights.



DLS488 Dome Light Switch 16.50



1941-47 Plastic Dome Light Switch: Nice reproduction of a hard to find switch. Made in ivory colored plastic. Fits 1941-47 except 1941 98 2 doors.

DLS417 Dome Light switch 28.50

1949-60 Chrome Interior Coat Hooks: Stamped steel and chrome plated.

CH496 1949-60 Coat Hook 8.50 ea.



Chrome Seat Adjuster Knob: Fits 1949-50 76 & 88, 1951-52 All models, 1957-60 All with manual seat adjuster. Chrome plated, T shaped knob with allen set screw.

4591925 Seat Adjuster Knob 29.50 ea.

Windlace Rubber Stop: Applies to many 2 Door Convertible & Holiday Coupe (2 Dr Htop) models from the 30s thru 60s. Rubber 'cap' attaches to the top of the door windlace, usually missing or deteriorated.

WRS30 Windlace Rubber Stop 30s-60s 11.50 pair



1933-38 Standard Shift Knob: Black plastic shift knob with knurled edges fits all 1933-38 Oldsmobiles with standard transmissions. Metal collar 7/16"-20 thread inserted into bottom of knob.

SK338 Shift Knob 16.50



1949-51 Seat Back Bumpers: Fits 1949-50 76-88 2 door models and 1951 88A 2 doors. 2 used per car.

SB491 Seat Bumpers 1949-51 7.50 ea.



1954-58 Seat Back Bumpers: Fit 1954-56, 1957-58 All 2 door models. Metal inserted. 4 per car.

SB546 1954-56 2 Doors 7.50 ea.

SB578 1957-58 2 Doors 7.50 ea.



Rear Quarter Arm Rest Ash Trays

Rear Arm Rest Ash Tray Frame and Sliding Cover:

Fits 1950 76-88 models, 1951-53 All Convertible and Holiday Coupe on the rear arm rest. We no longer have any of the ash trays that fit in this piece.



ATF513 Ash Tray Frame and Cover 29.50 ea.

1954-60 Holiday Coupe and Convertible Rear Quarter Arm Rest Ash Trays and Bezel: Ash trays measure 2 1/2" X 2 1/4" and Bezel measures 2 1/2" X 3 1/8". Quality items made from stainless steel and chrome plated. AT547 features separate raised knob while AT6145 uses an integral knob stamped in lid.

AT547 Ash Tray fits 1954-58 All Holiday Coupes and Convertibles 29.50 ea.



AT6145 Ash Tray fits 1959-60 88 Holiday Coupes and Convertibles 29.50 ea.



AT548B Ash Tray Bezel for above ash trays. 14.50 ea.



1950-56 SHIFT KNOBS AND TURN SIGNAL KNOBS

1950-56 Hydramatic Shift and Turn Signal Knobs are the proper color, shape and detail. 1950-51 Knob is Dark Charcoal, 1952 is Grey, and 1953-56 Knobs are Ivory only, you will have to paint to match other colors.

TSL50 Turn Signal Lever Assembly 1950 All 29.50

TSK501 Turn Signal Knob 1951 All 9.50

TSK520 Turn Signal Knob 1952 All 9.50

TSK536 Turn Signal Knob 1953-56 All 9.50

SK501 Shift Knob 1950-51 All with Hydramatic 12.50

SK520 Shift Knob 1952 All with Hydramatic 12.50

SK536 Shift Knob 1953-56 All with Hydramatic 12.50



1950-57 STEERING WHEELS

Wheels have the correct framework and injection molded plastic for strength and appearance. These Steering Wheels are an exact copy of wheels supplied by Oldsmobile. Steering wheels listed are limited to one run only.

SW501	Charcoal Steering Wheel 1950-51 All with Deluxe Wheel	295.00
SW502	Grey Steering Wheel 1952 All with Deluxe Wheel	295.00
SW534	Ivory Steering Wheel 1953-54 All with Power Steering Insert	325.00
SW556	Ivory Steering Wheel 1955-56 All with Deluxe Wheel	295.00
SW578	Ivory Steering Wheel 1957 All with Deluxe Wheel	295.00



“GM Power Steering” Plastic Wheel Insert: Fits 1953-54 steering wheels on all models equipped with power steering.

GMW534 “GM Power Steering” insert 24.50

1949-52 DELUXE HORN CAPS

1948 98, 1949-52 Deluxe Horn Cap Center Plastic: Original plastic horn cap clear cover is usually cracked or crazed over the years. You will need to disassemble the horn cap unit, repaint the globe area, and replace the old plastic cover with the new part.

Restored versions of the 1949-52 Horn Center Cap Assemblies are also available. **Core charge on restored horn cap assembly is 50.00.**

HCE490	Deluxe Horn Cap Plastic Center Cover Only	1948 98, 49 All	19.50
HCE502	Deluxe Horn Cap Plastic Center Cover Only	1950-52 All	19.50
HC490	Restored Horn Cap Assembly (gold globe with blue)	1949 All	112.00
HC501	Restored Horn Cap Assembly (gold globe with blue)	1950 All	112.00
HC510	Restored Horn Cap Assembly (silver globe with blue)	1951 All	112.00
HC502	Restored Horn Cap Assembly (silver globe with silver)	1952 All	112.00



1934-56 FISHER BODY PLATES

Perfect copies with correct color combinations. Body plates are located on left side of cowl (1934-40) or on front lower portion of seat (1941-56).

4102041 Fisher Body Plate 1934-40 All 14.50 ea.

4116759 Fisher Body Plate 1941-56 All 14.50 ea.



DOOR SILL PLATES

Finely reproduced examples that exceed the quality of any new old stock plates. Correct anodized aluminum construction with pre-drilled holes for easy installation. New screws included. SP502D and SP590D include fisher body plates per original, all others are smooth anodized aluminum and do not use fisher body plates.

SP502D	Door Sill Plates	1949-50 76-88 Holiday Coupe and Convertible	219.00 pair
SP4904D	Door Sill Plates	1949-50 76-88, 1951 88A 4 Door Sedan Sill Plates	245.00 set
SP5564D	Door Sill Plates	1955-56 4 Door Sedan (has center post)	99.00 4 pc. set
SP554HS	Door Sill Plates	1955-56 4 Door Holiday Sedan (no center post)	99.00 4 pc. set
SP562D	Door Sill Plates	1955-56 All 2 Doors	92.00 pair
SP782D	Door Sill Plates	1957-58 All 2 Doors	95.00 pair
SP590D	Door Sill Plates	1959-60 All 2 Doors	115.00 pair

BACK-UP AND HEADLIGHT RIMS

HEADLIGHT RIMS (Bezels): 1948-53 Headlight Rims are die-stamped stainless steel reproductions. 1948-53 Rims are complete with rubber seals and retainers. 1955-57 Headlight Bezels are Cast Chrome reproductions made using expensive high pressure tooling. Rubber seals around headlight bulbs are included.

5940756	Headlight Stainless Steel Rim	1948 98, 1949 All, 50 76-88, 51 88A	38.00 ea.
5938928	Headlight Stainless Steel Rim	1950 98, 1951-53 All except 1951 88A	42.00 ea.
924535	Headlight Bulb Chrome Retaining Ring (Stamped Steel)	1940-55 All	27.50 ea.
5945771	Headlight Cast Chrome Bezel with seal	1955 All	89.50 ea.
5946763	Headlight Cast Chrome Bezel with seal	1956 All	89.50 ea.
5947804	Headlight Cast Chrome Bezel with seal	1957 All	89.50 ea.



5941555 1954-55 Back-up Light Bezel: Beautiful die-stamped reproduction of a very hard to find part. These back-up bezels fit 1954-55 All with Back-up Lights.
5941555 Back-up Light Bezel
 1954-55 All 27.50 ea.



ROCKER PANEL MOLDINGS

1955 AND 1957 98 ROCKER PANEL MOLDINGS: Excellent reproductions of very hard to find parts. It can be expensive to repair and buff originals, which are usually dented or distorted over time. Sold in pairs only. Clips can be ordered separately or with moldings.

566338/9	Rocker Panel Moldings	1955 Super 88, 1955 98 4 Door Sedan	without clips 150.00 pr.	with clips 195.00 pr.
566340/1	Rocker Panel Moldings	1955 98 Holiday Coupe & Conv. & Holiday Sedan	150.00 pr.	195.00 pr.
569929	Rocker Panel Moldings	1957 98 All Models	150.00 pr.	195.00 pr.

Rocker Panel Molding Clips: We have reproduced the following rocker panel molding clips for Oldsmobile.

RMC490	Rocker Panel Molding Clip (uses 22 per car)	1949 All Models	3.50 ea.
RMC501	Rocker Panel Molding Clip (uses 14 per car)	1950 76-88 1st type	3.50 ea.
RMC502	Rocker Panel Molding Clip (uses 18 per car)	1950 76-88 2nd type	3.50 ea.
RMC530	Rocker Panel Molding Clip (uses 22 per car)	1953 98 and Fiesta	3.50 ea.
RMC545	Rocker Panel Molding Clip (uses 22 per car)	1954 Super 88, 1955 Super 88-98, 1957 98 only	3.50 ea.
RMC580	Rocker Panel Molding Clip (uses 22 per car)	1958 All Models	4.50 ea.



FRONT AND REAR BUMPER BOLTS: We have experienced difficulties in finding a company to manufacture cold rolled steel bumper bolts in small quantities at a reasonable price. It is our decision to make one final run of the BB125 and BB125A. However, the cost to make 2000 pieces has skyrocketed. Once supply is exhausted on the remaining bumper bolts, they will be discontinued.

BB121	Bolt with Nut	1941 All Front or Rear	4.50 ea.
BB125	Bolt with Nut	1948 98, 1949-53 3 1/2" overall length	9.50 ea.
BB125A	Bolt with Nut	1948 98, 1949-53 2 1/4" overall length	7.50 ea.
BB126	Bolt with Nut	1948 98, 1949-53 All Rear License Plate Bracket	9.00 pr.
BB127	Bumper End Plug (Short Bumper Bolt, unthreaded, retained by clip which is included)	1948 98, 1949-53 All	9.00 pr.



EXHAUST DEFLECTORS AND ORNAMENTS



Exhaust Deflector: Fashionable accessory used on all 1936-55 Oldsmobiles. Copied from an original 1949-55 Deflector.

982511 Exhaust Deflector 26.50



1956 Dual Exhaust Bumper Ornament: Used on all 1956 Oldsmobiles with factory dual exhaust and bumper.

Hardware included to attach to factory bumper. Perfect stamping and finish. These will be discontinued when supply is exhausted.

568623 Dual Exhaust Ornament 55.00 ea.

1957 Dual Exhaust Ornament:

Used on all 1957 Oldsmobiles with factory dual exhaust and bumper. A difficult part to produce requiring different manufacturing procedures. Correct stainless cap, aluminum four studded body, and exhaust baffle.

569641 Dual Exhaust Ornament 55.00 ea.



HOOD INSULATION

We have located the 1 inch thick yellow hood insulation used on 1952-60 OLDSMOBILES. All Pads are die cut with original configuration. Some Hood Pads are held in place by the hood tie bars, while others are glued in place. For Pads requiring glue, we suggest 3M #80 Spray Adhesive available at local parts stores.

Yellow side of hood insulation always faces engine.

HI523	Hood Insulation	1952-53 All	36.50
HI546	Hood Insulation	1954-56 All	36.50
HI570	Hood Insulation	1957 All	36.50
HI580	Hood Insulation	1958 All	36.50
HI590	Hood Insulation	1959-60 All	36.50

1949-60 ANTENNA PARTS

1949-60 Antenna Mast, Plastic Nut, and Rubber Gasket:

MAG456	Manual Antenna Mount Pad	1949-56 All	4.50
MAG570	Manual Antenna Mount Pad	1957 All	4.50
MAG570A	Power Antenna Mount Pad	1957 All	6.50
AN457	Manual Antenna Black Plastic Nut	1949-57 All	11.50



Manual Antenna Package: Universal 3 piece mast and lead in. Correct appearance for 1946-60 models.

A901 Antenna Package 24.50



Door Jamb Strikers: Fits 1940 90, 1941-48
All except 1948 98 and 1954-59 All Models.
2 Door models will need one pair, 4 Doors
need two pair.



DJS418 Door Striker 1940 90, 41-48
All except 1948 98 21.50 ea.



DJS549 Door Strikers 1954-59 All 43.00 pr.

1932-47 Door and Trunk Handle

Ferrules: Fits 1932-40 Door and 1929-47 Trunk Handles. Chrome plated ferrule with rubber grommet.



DF287 1932-37 Door, 1929-37 Trunk Handle Ferrule 13.75 ea.



DF380 1938-39 all, 1940 60-70 Series Door Handles and 1938-47 All Trunk Handle 13.75 ea.

Door Lock Ferrule Tool: Installation tool for 1932-47 door and trunk handle ferrules.

DFTOOL Ferrule installation tool 39.50



TRUNK HINGES

THS40 Trunk Hinge Set: This set fits 1940 60-90 Coupe and Convertible, 1941 66-68-98 Coupe and Convertible, 1942-48 66-68 Coupe only. Chrome Hinge set includes rubber mounting pads.

THS40 Hinge Set 89.50 set



THS42 Trunk Hinge Set: For 1942-48 66-68 Convertibles only. Chrome Hinge set includes rubber mounting pads.

THS42 Hinge Set 89.50 set

1949-50 76-88, 1951 88A Front Door Check Link: Includes dovetail as original. Old links are vulnerable to breakage. New links will need to be painted car color. Not applicable to rear doors.

DCL491 Door Check Link 16.50 ea.



1950 NEUTRAL SAFETY SWITCHES AND ACCESSORIES

We have located a decent quantity of the GM 1950 Neutral Safety /Back-up Light Switches Limited availability. We also have original wire harness straps and clips used on accessory wiring installations.

5939582 1950 All Hydramatic Neutral Safety/Back-up Light Switch 29.50



WHS400 1940-50's Wire harness brass strap. Used to attach accessory harness wires to main front harness. Requires 3 or 4 per car. 1.50 ea.

WHC500 Wire Harness Clip. Used to attach accessory wires to frame and other sheet metal areas. Used on 1940-50's Models. Up to 10 per car. .50 ea.

GAS CAPS

Gas Caps: Exact reproductions of the original Gas Caps used on 1934-39 All Models, 1940 60-70 Series, and 1941-58 All Models.

GC39 Gas Cap 1934-39 All Models, 1940 60-70 Series 12.50

511124 Gas Cap 1940 90, 1941-58 All 17.50



1950-58 GLASS WASHER JAR CAPS

New Washer Jar Caps are now available to fit 1950-57 and 1958 Oldsmobile. Quality cap replaces often worn or rusted original. No internal parts or jars are included or available at this time.

WJC507 Washer Jar Metal Cap 1950-57 All 59.00

WJC580 Washer Jar Metal Cap 1958 All 59.00



FIREWALL INSULATORS



These insulators are precision made with all the areas and cutouts for easy installation. The pads are molded rubber bonded to the original style insulation material. Old insulators are usually deteriorated beyond use and are essential for restorers who insist on a complete job. You must reuse your old fasteners and clips as no source has been located as yet. Most applications are in stock for immediate shipment.

FP356 Firewall Insulator 1935-36 All	193.00	FP530 Firewall Insulator 1953 except Fiesta	199.00
FP370 Firewall Insulator 1937 All	209.00	FP530F Firewall Insulator 1953 Fiesta Only	209.00
FP380 Firewall Insulator 1938 6 Cylinder	209.00	FP540 Firewall Insulator 1954 All	199.00
FP390 Firewall Insulator 1939 60 Series	209.00	FP546 Firewall Insulator 1955-56 All	199.00
FP400 Firewall Insulator 1940 70 Series	209.00	FP570 Firewall Insulator 1957 All	189.00
FP428 Firewall Insulator 1942-48 60 Series	209.00	FP580 Firewall Insulator 1958 All	189.00
FP491 Firewall Insulator 1949-50 76-88, 1951 88A	199.00	FP590 Firewall Insulator 1959 All	193.00
FP512 Firewall Insulator 1951 S 88, 1952 All	199.00	FP600 Firewall Insulator 1960 all exc. 98	193.00

GLOVE BOXES

Glove Box Assemblies: Exact die cut reproductions folded and stapled for exact fit. These cloth-lined Glove Boxes are available for the following models.

GB37 Glove Box 1937 All	36.50	GB53 Glove Box 1953 All	36.50
GB38 Glove Box 1938 All	36.50	GB54 Glove Box 1954 All, 1955 exc. A/C	36.50
GB39F Glove Box 1939 60 Series	36.50	GB55A Glove Box 1955 All with A/C	38.50
GB39 Glove Box 1939 70-80 Series	36.50	GB56 Glove Box 1956 All except A/C	36.50
GBX40 Glove Box 1940 All	36.50	GB56A Glove Box 1956 All with A/C	38.50
GB41 Glove Box 1941-48 exc 1948 98	36.50	GB57 Glove Box 1957-58 All exc A/C	38.50
GB49 Glove Box 1948 98, 1949 All	36.50	GB57A Glove Box 1957-58 All with A/C	43.50
GBX50 Glove Box 1950 76-88, 1951 88A	36.50	GB59 Glove Box 1959-60 All exc A/C	36.50
GB52 Glove Box 1952 All	36.50		

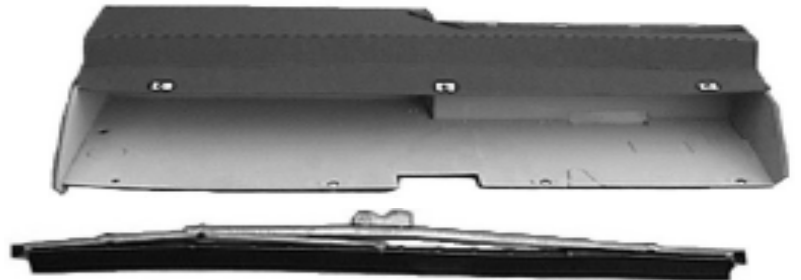
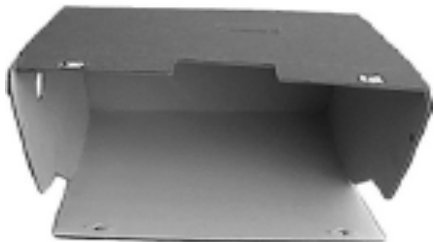

WINDSHIELD WIPER BLADES AND ARMS

We are able to supply the following windshield wiper blades and arms. Please note that 33111, 33122 and 33150 Wiper Blades are satin finished only. They are not the original style polished stainless steel.

WWN390 Windshield Wiper Arm Chrome Nut	1936-40 All	4.50 ea.
WWA320 Windshield Wiper Arm	1936-40 All	18.50 ea.
WWA418 Windshield Wiper Arm	1941-48 All except 1948 98	19.50 ea.
TAU-8 Windshield Wiper Blade (8 inch)	1932-38 All	11.00 ea.
TAU-9 Windshield Wiper Blade (9 inch)	1939-48 All except 1948 98	11.50 ea.
33111 Windshield Wiper Blade (satin finish)	1949-53 All except 1953 Fiesta	19.50 ea.
33122 Windshield Wiper Blade (satin finish)	1954-56 All	19.50 ea.
WB546 Windshield Wiper Blade (stainless)	1954-56 All with hook type arm	39.75 ea.
WWF578 Windshield Wiper Refill Only (rubber portion)	1957-58 All	9.50 ea.
33150 Windshield Wiper Blade (satin finish)	1959-60 All	19.50 ea.



ACCESSORY RUBBER FLOOR MATS, ACCELERATOR PEDALS AND BRAKE PADS

Accessory Rubber Floor Mats: Original accessory used exclusively on 1953-56 Oldsmobiles. Also applicable to 1957-58 and models prior to 1953. Superb reproduction of a rare original part. Order two pair if you want to install front and rear mats in your Oldsmobile. 18 1/2"H X 16 3/4" W.



FM536B	Black Floor Mats	Models to 1958	65.00 pair
FM536BL	Blue Floor Mats	Models to 1958	65.00 pair
FM536R	Red Floor Mats	Models to 1958	65.00 pair
FM536GY	Grey Floor Mats	Models to 1958	65.00 pair
FM536GR	Green Floor Mats	Models to 1958	65.00 pair

ACCELERATOR PEDALS: Exact copies as per original with steel core molded into rubber.



AP37	Accelerator Pedal (specify brown or black)	1937-38 All	29.50
AP49	Black Accelerator Pedal	1949-52 All with stud mount. Will not fit 1949-51 98, and 1949 models with lever and bracket pedal.	32.00
AP54	Black Accelerator Pedal	1954 All Models	29.50
AP55	Black Accelerator Pedal	1955-56 All Models	39.50
AP57	Black Accelerator Pedal	1957-58 All Models	39.50
SP34	Black Starter Pedal Pad	1935-48 All except 1946-48 98	12.00

1934-58 BRAKE-CLUTCH PEDAL PADS: Original style brake and clutch pedal pads will fit over your existing metal brake pedal base. Check your application carefully.

CB34	Brake-Clutch Pedal Pads 1934-39	All Models (specify black or brown)	18.00 pair
CB40	Brake-Clutch Pedal Pads 1940-48	All Models (brown)	12.50 ea.
CB49	Brake-Clutch Pedal Pads 1949-52	All Models (black)	12.50 ea.
CB53	Brake-Clutch Pedal Pads 1953-58	Standard Transmission and all 1953-58 Hydramatic equipped cars with manual brakes.	12.50 ea.



1954-58 POWER BRAKE PAD ASSEMBLY AND PARK BRAKE PADS

The power brake pad assemblies now include the metal backing plate, brake rod grommet, and the correct "Power Brake" script.

PB54M	Power Brake Pad Assembly 1954-56	All with power brake	34.50
PB57M	Power Brake Pad Assembly 1957-58	All with power brake	34.50
PB56	Park Brake Pedal Pad 1956	All	12.50
PB58	Park Brake Pedal Pad 1957-58	All	16.50



TLG501

DCG61

1950-60 OLDSMOBILE HANDLE AND LOCK GASKETS

1950-58 DOOR LOCK CYLINDER & TRUNK LOCK GASKET: Proper die cut rubber lock cylinder gasket for your Oldsmobile.

TLG501	Trunk Lock Gasket 1950 All, 1951 88A models	3.75
DCG61	Trunk Lock Gasket 1951-53 All except 1951 88A, 1955-58 All	1.95
DCG61	Door Lock Cylinder Gasket 1954-56 All, 1959-60 All	1.95

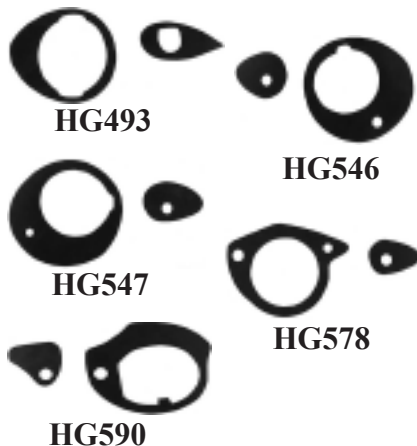

1949-60 DOOR HANDLE GASKETS

Nice finishing detail to any new paint job. Die cut rubber. Two piece door handle gasket services one handle (one large-one small gasket).

HG493	Handle Gasket 1949 76-88, 1950-53 All 2 and 4 door models.	3.75 ea.
HG546	Handle Gasket 1954-56 all models except 2 door hardtop and convertible.	3.75 ea.
HG547	Handle Gasket 1954-56 All 2 door hardtop and convertible	3.75 ea.
HG578	Handle Gasket 1957-58 All models front and rear	3.75 ea.
HG590	Handle Gasket 1959-60 All models front and rear	3.75 ea.

TRUNK COMPARTMENT



We have reproduced the Brown Chain-Linked Material used on most 1946-56 Oldsmobiles. Some 1955-56 Models used different colors such as green, tan, blue, gray, etc. There are no plans to offer these colors in the future. Samples are available on the trunk material and trunk cardboard at no charge. Although 1946-56 Brown Trunk Cardboard did vary from year to year, we have only one shade available. Trunk material will require sewing and in some cases the material must be sewn to the cardboard. We recommend a trim shop for this type of work. For 1957, Holiday Coupe and Convertible are the only models we have available. 1958-60 Owners, your trunk material and cardboards are isolated from the other years. There are no plans to reproduce the material.

- TM300 Brown Chain-Linked Trunk Material:** For most 1946-56 Models 49.00 yard
Sold by linear yard approximately 56" X 36". Most models use 3 1/2 yards.
- TM350 Grey Embossed Trunk Material:** For 1957 S88-98 Models. Can be used on 88 Models. 55.00 yard
Sold by linear yard approximately 56" X 36". Most models use 4 yards.

TRUNK CARDBOARD SETS

TCK49S	Trunk Cardboard Kit	1949-50 76-88, 1951 88A 2 & 4 Door Sedans (vertical spare only)	89.50 (3 pc)
TCK49CS	Trunk Cardboard Kit	1949-50 76-88 Club Sedans	106.50 (5 pc)
TCK49CC	Trunk Cardboard Kit	1949-50 76-88, 1951 88A Club Coupes	106.50 (4 pc)
TCK49HC	Trunk Cardboard Kit	1950 76-88 Holiday Coupes	106.50 (4 pc)
TCK49CV	Trunk Cardboard Kit	1949-50 76-88 Convertibles (vertical mounted spare only)	129.00 (6 pc)
TCK51S	Trunk Cardboard Kit	1951-53 S88 & 88 2 & 4 Door Sedans	89.00 (3 pc)
TCK51HC	Trunk Cardboard Kit	1951-53 Super 88 Holiday Coupes	93.00 (3 pc)
TCK51CV	Trunk Cardboard Kit	1951-53 Super 88 Convertibles	89.00 (3 pc)
TCK52S	Trunk Cardboard Kit	1952-53 98 4 Dr Sedan	93.50 (5 pc)
TCK52HC	Trunk Cardboard Kit	1952-53 98 Holiday Coupe	93.50 (5 pc)
TCK52CV	Trunk Cardboard Kit	1952-53 98 Convertible and 1953 Fiesta Convertible	89.00 (5 pc)
TCK54S	Trunk Cardboard Kit	1954-56 S88 & 88 2 & 4 Door Sedans	106.00 (3 pc)
TCK54HC	Trunk Cardboard Kit	1954-56 S88 & 88 Holiday Coupes	103.00 (3 pc)
TCK54CV	Trunk Cardboard Kit	1954-56 S88 & 88 Convertibles	86.00 (2 pc)
TCK55S	Trunk Cardboard Kit	1954-56 98 4 Door Sedans	103.00 (3 pc)
TCK55HC	Trunk Cardboard Kit	1954-56 98 Holiday Coupes	103.00 (3 pc)
TCK55CV	Trunk Cardboard Kit	1954-56 98 Convertibles	93.00 (3 pc)
TCK57C	Trunk Cardboard Kit (grey color)	1957 98 Holiday Coupe	133.00 (5 pc)
TCK57B	Trunk Cardboard Kit (grey color)	1957 98 Convertible	106.00 (4 pc)
TCK57D	Trunk Cardboard Kit (grey color)	1957 Super 88 Holiday Coupe	133.00 (3 pc)
TCK57E	Trunk Cardboard Kit (grey color)	1957 Super 88 Convertible	106.00 (2 pc)



FRONT DOOR AREA LOWER KICK PANELS: Correct die cut profile in neutral white waterproof cardboard. Spray paint or color dye to match interior.

KP492	Lower Kick Panels	1949-50 76-88, 1951 88A	36.50 pair
KP520	Lower Kick Panels	1952 All	36.50 pair
KP545	Lower Kick Panels	1954-55 88 Models	36.50 pair
KP560	Lower Kick Panels	1956 All 88-S88	36.50 pair
KP570	Lower Kick Panels	1957 Super 88-98 except Convertibles	36.50 pair
KP570C	Lower Kick Panels	1957 Super 88-98 Convertibles	36.50 pair
KP571	Lower Kick Panels	1957 88 Models except Convertibles	36.50 pair
KP571C	Lower Kick Panels	1957 88 Convertibles	36.50 pair

Spare Tire Retaining Nut: Exact copy of the original part with cadmium plated finish. Fits 1941-48 All and 1949-58 All with vertical spare tire.

- STN458** Spare Tire Retaining Nut 9.50



RUBBER PARTS

GB10 1941-60 Glove Box Bumpers: Fits most models 1.00 ea. 

GB10 1941-53 Gas Door Bumpers: 1941-53 all except 1950-53 76-88 1.00 ea. 

GB560 Glove Box Hinge Grommet: Fits 1956-60 all models 4.50 ea. 

GB15 Gas Door Bumpers: 1950-53 76-88, 1954-56 all, includes screws 4.50 pr. 

GB20 1957 Gas Door Bumpers: For 1957 all models 9.50 pr. 

GF57 Gas Filler Door Flap: Fits all 1957 models 23.50 

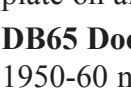
LB558 Rear License Plate Bumper: Fits in rear bumper behind license plate on all 1955-58 Models 4.50 

DB65 Door Lock Pillar Bumper: Fits 1950-60 most models (flat round) 2.00 ea. 

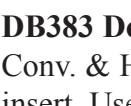
DB80 Door Lock Pillar Bumper: 1950-60 most applications where there are two small holes side by side 2.50 ea. 

DB383 Door Pillar Bumper: Fits 1938-53 Conv. & Hol. Cpe. Flat square with metal insert. Uses 4 screws. 14.50 each 

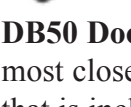
DB45 Door Lock Pillar Bumper: 1937-60 Most closed models, others 1949-60. Self retaining, fits in one round hole 2.00 ea. 

DB50 Door Lock Pillar Bumper: 1949-57 most closed models, retained by a screw that is included 2.00 ea. 

DB59 Door Lock Pillar Bumper: 1959-60 Holiday Coupe and Convertible, self retaining, fits in rectangular hole 3.50 ea. 

DB59A Door Lock Pillar Bumper: Same design as DB59 but smaller size. Fits 1959-60 some models. 3.50 ea. 

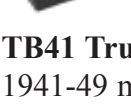
DB60 Door Lock Pillar Bumper: 1957-60 4 Door Sedans. Self retaining, fits in rectangular hole. 3.00 ea. 

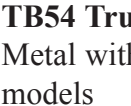
TB41 Trunk Ledge Bumper: 1941-49 most models. 4.00 ea. 

TB54 Trunk Ledge Bumper and Adjuster: Metal with rubber cushion, fits all 1954-56 models 6.50 ea. 

TB56 Trunk Ledge Bumper: 1950-58 All except 1954-56 2.50 ea. 

HB38 1938-40 Hood Bumper: All models and uses up to 20 per car. 1.50 ea. 

HB41 Hood Bumper: 1941 All Models 5.00 ea. 

HB42 Hood Bumper: 1942-48 66-68 Series 1.50 ea. 

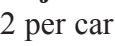
HB54 Hood Ledge Bumper and Adjuster: Fits 1954-60 all models 2 per car 8.50 ea. 

HB49 Hood to Grille Bar Bumper: Fits 1948 98, 1949-52 all 4.50 ea. 

Hood to fender bumpers are located on upper edge of fender to keep the hood from contacting fender when closed. Side views are shown. 6-8 used per car.

HB50 Hood to Fender Bumper: Fits 1948 98, 1949-52 all 4.50 ea. 

HB53 Hood to Fender Bumper: Fits 1953 all models 4.50 ea. 

HB55 Hood to Fender Bumper: Fits 1954-56 all models 4.50 ea. 

HB57 Hood to Fender Bumper: Fits 1957-58 all models 4.50 ea. 

HB59 Hood to Fender Bumper: Fits 1959 all models 4.50 ea. 

DJP41 Door Jamb Light Switch Pad: 1941-56 All models 3.50 ea. 

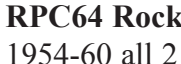
RPC64 Rocker Panel Inner Cover: For 1954-60 all 2 Doors, covers drain hole at rear of rockers, 2 per car. 4.50 ea. 

Bumper Bar Grommets: Seals between body and bumper bar. 

BG387 1937 all front 33.50 pr. 

BG379 1937-38 all rear 34.50 pr. 

BG390 1939 all front and rear 34.50 pr. except for 60 series rear 

BG390F 1939 60 series rear 34.50 pr. 

BG400 1940 all front 34.50 pr. 

BG401 1940 60 series rear 36.50 pr. 

BG402 1940 70 & 90 rear 36.50 pr. 

Gear Shift Lever Boots: One of the vulnerable parts of your interior that crack and fade with age.

GS328 Boot 1932-38 all black or brown 13.50 

GS480 Boot 1948 all grey 11.50 

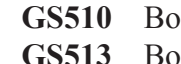
GS490A Boot 1949-50 all grey 11.50 

GS490B Boot 1949-50 all black 11.50 

GS510 Boot 1951 all black 11.50 

GS513 Boot 1952 all, 1953 S.T. grey 11.50



RUBBER BEADED MOUNTING PADS



Top Quality Rubber Beaded Mounting Pads: These pads add the professional touch to your restoration, prevent moisture, and eliminate paint chips when assembling the body pieces.

PL36	Park Light Mounting Pad	1936 All	16.50 ea.
TL36	Tail Light Stanchion to Fender Mounting Pad	1936 All	15.00 ea.
HL36	Headlight Mounting Pad	1936 All	19.50 ea.
HL37F	Headlight Mounting Pad	1937 All 6 Cylinder	18.50 ea.
HL37L	Headlight Mounting Pad	1937 All 8 Cylinder	18.75 ea.
TLO37LH	Trunk Light Ornament Mounting Pad	1937 8 Cylinder 2 & 4 Door Sedan	19.75 ea.
TLO37CR	Trunk Light Ornament Mounting Pad	1937 All Coupes & Convertible	13.50 ea.
TLO37FB	Trunk Light Ornament Mounting Pad	1937 6 Cylinder 2 and 4 Door Sedans	15.00
TH378	Trunk Hinge Mounting Pad	1937-38 All (2 piece set)	19.50 set
HL38	Headlight Mounting Pad	1938 All	23.50 ea.
TL38A	Tail Light Mounting Pad	1938 All 2 & 4 Door Sedans	16.50 ea.
TLO38	Trunk Light Ornament Mounting Pad	1938 All	16.50 ea.
HL39	Headlight Mounting Pad	1939 All	19.75 ea.
LL39	License Lamp Mounting Pad	1939 All	15.00 ea.
TL40	Tail Light Mounting Pad	1939-40 60 2 & 4 Door Sedans	19.50 pr.
TL40A	Tail Light Mounting Pad	1939-40 60 Coupes & Convertible	19.50 pr.
TL40B	Tail Light Mounting Pad	1939 70-80 & 1940 70 2 & 4 Door Sedans	19.50 pr.
TL40C	Tail Light Mounting Pad	1939 70-80 & 1940 70 Coupes & Conv.	19.50 pr.
HL401	Headlight to Fender Mounting Pads	1940-50 All exc 1950 98, 1951 88A	15.00 ea.
HLR407	Headlight Rim Seals	1940-54 All	14.50 ea.
TL41	Tail Light Mounting Pad	1941 66-68	19.50 pr.
TL41A	Tail Light Mounting Pad	1941 76-78	23.50 pr.
TL41B	Tail Light Mounting Pad	1941 96-98	21.50 pr.
TL427	Tail Light Mounting Pad	1942-47 66-68-76-78	24.50 pr.
TE428	Trunk Handle Escutcheon Mounting Pad	1942-48 66-68 except Club Sedan	21.75
TE49	Trunk Handle Escutcheon Mounting Pad	1949 76-88	21.50
CTL490*	Crown & Tail Light Mounting Pad (4 pc set)	1949 76-88, 1950 76	59.50 set
CTL501*	Crown & Tail Light Mounting Pad (4 pc set)	1950 88, 1951 88A	59.50 set
CTL512*	Crown & Tail Light Mounting Pad (4 pc set)	1951-52 Super 88	59.50 set
BU523	Back-up Light Mounting Pad	1952 98, 1953-55 All	9.50 ea.
HL513	Headlight Mounting Pad	1950 98, 1951 S88-98, 1952-53 All	23.50 ea.
HLR557	Headlight Rim Seals	1955-57 All	15.00 ea.

*Because of the convex curvature of the 1949-52 Crown Moldings and Tail Lights, splitting the mounting pads may be necessary for proper fit. Splitting the pad will draw the rubber in or out, whichever the case.

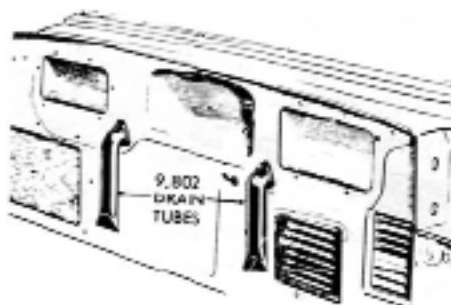

Cowl Drain Tubes: Used on All 1954-58 Oldsmobiles. These rubber tubes are always brittle from engine heat and deteriorate from age. We had a difficult time locating useable parts to copy. A necessary detail item for your engine compartment restoration. You will need to reuse your old mounting hardware.

565496	Cowl Vent Drains	1954-56 All	26.50 pr.
570288	Cowl Vent Drains	1957-58 All	26.50 pr.

COWL AND FIREWALL RUBBER PARTS



Cowl or Radiator Channeled Lacing:
Tar treated as original. 1925-39 All.
CL30 Cowl lacing 3.00 per ft.

CL40 Hood to Cowl Lacing: Six foot rubber extrusion for 1940 60-70 Series.
CL40 Cowl lacing 21.50

1942-48 60 Series Hood to Cowl Lacing Strip:
Extremely difficult part to manufacture. Small rubber push-in tabs are molded into the rubber strip per the original. Part was made for 1942-48 66-68 models, but can be used on 1941 66-68, and 1941-48 76-78 models with minor trimming and drilling of holes to align tabs.
CL42 Cowl lacing strip 93.00



1950 76-88, 1951 88A Hood to Cowl Lacing Strip: Nice duplication of hard to manufacture part. Center molded section pre drilled for installation.
CL49 Cowl lacing strip 99.00

1951-59 Hood to Cowl Lacing Strip: Fits 1951 S88-98, 1952-59 all models. Five foot molded extrusion. Reuse your old retaining clips. Holes are not predrilled.
CL50 Cowl lacing strip 34.50

CB490  CB491 

1946-53 Cowl Bumpers: CB490 retained by sheet metal screws. CB491 Self Retaining design.

CB490 Cowl Bumper 1946-50, 1951 88A 7.50 pr.
CB491 Cowl Bumper 1951 S88-98, 52-53 all 7.50 pr.

Upper Radiator Baffle Seals: Fits 1956 88 models without air conditioning and 1957 all models.
URS56 Upper radiator baffle seal 1956 88 21.50
URS57 Upper radiator baffle seal 1957 all 21.50

1937-53, 1956-58 Main Wiring Harness Grommet:
FG378 1937-52, 1956-58 Grommet 16.50
FG530 1953 only Grommet 23.50

1949-58 Firewall Grommet: Fits ignition switch to coil wire, heater, turn signal, back-up and fog lamp wires.
FG498 Firewall grommet 4.75 ea. 

1939-54 Firewall Grommet: Fits 1939-48 fuel gauge wire, 1949-50, 51 88A fuel gauge and horn wire, 1949-54 hood latch and fresh air cable.
FG374 Firewall grommet 5.00 ea. 

1939-47 Ignition Switch Cable to Coil Firewall Grommet:
FG377 Firewall grommet 9.50 

1940-54 Speedometer Cable Grommet:
FG404 Firewall grommet 7.50 



1950-58 Hand Brake to Frame Lever Cable Grommet: Fits 1950-58 all models except 1950-51 98. Curved hole to accommodate cable bend.
FG508 Brake cable grommet 9.50 

1939-48 Horn Wire, Throttle, Speedometer Cable, Wiper Pipe, and Temp Gauge Firewall Grommet: fits 1939-48 all except 1948 98.
FG398 Grommet 8.75 

1948-56 Gas Gauge Wire Grommet:
FG456 Gas wire grommet 2.50 

1952-56 Rear Wheel House Electrical Wire Grommet:
QP526 Wire Grommet 4.75 ea. 

1940-57 Light Wire Grommet: Fits 7/8" hole in light assemblies. Up to 8 per car.
LG507 Light wire grommet 6.75 ea. 

1949-60 Body and Floor Plug Kit: 10 each of two different size plugs. (1/2" & 7/8")
BFP490 Plug kit (20 pc pkg.) 28.50 
FG515 3/4" Firewall plug 2.75 ea. 

Windshield Wiper Transmission Mounting Pads: A small part that adds extra fine detail to your Oldsmobile restoration.
WW378 1937-38 All 2.95 ea.
WW400 1940 60, 90 2.95 ea.
WW400 1941 96-98, 41-48 76-78 2.95 ea.
WW418 1941-48 66-68 2.95 ea.
WW490 1949-50 76-88 2.95 ea.
WW513 1951-53 All 2.95 ea.
WW546 1954-56 All 2.95 ea.
WW578 1957-58 All 2.95 ea.

Hydraulic Pump Mount: 1946-54 with hydraulic window and top system. 3 per car.
TMG454 Pump Mount 8.50 ea. 

Convertible Top Motor Mounting Grommet: 1955-60 all with power convertible top. Usually 4 per car.
TMG642 Top motor grommet 3.50 ea. 

WINDOW CHANNEL

Preformed pieces are not available for any of these models. We supply sufficient measurements in our complete kits to re-channel one car or you can purchase channel strips individually. In all cases a certain amount of trimming and bending is required. For rigid channels, rivets are used and sweepers use staples or clips. Rivets and staples can be obtained from your local hardware store. Kits do not include windshield, rear window, or vent window rubber. These items can be found on pages 25-27 in this catalog.

WINDOW CHANNEL KITS: Includes rigid and flexible channel, flexible sweepers and staples or sweeper clips. Each kit services one car. Window cushions and side window run clips (514C or 515C) are not included in kits.

CK100	Window channel kit	1933-60 4 door sedans and station wagon (does not include rear sliding window channel)	209.00
CK200	Window channel kit	1933-60 2 door sedans and coupes	189.00
CK300	Window channel kit	1933-56 2 door convertible	139.00
CK300A	Window channel kit	1957-60 2 door convertible	149.00
CK400	Window channel kit	1949-56 2 door hardtop (no center post)	139.00
CK400A	Window channel kit	1957-60 2 door hardtop (no center post)	159.00
CK500	Window channel kit	1955-60 4 door hardtop (no center post)	169.00
CK600	Window channel kit	1936-41 2 door business coupe	149.00

625C Sweeper Clip: Used in attaching outer flexible sweeper. For use on all 1933-60 models. Two doors usually require 12 clips, 4 doors require 26.

625C Sweeper clip .75 ea.



625C



514C



515C



WB408

Side Window Run Clips: 2 styles used on 1939-50 models. Check your car for proper clip and quantity needed. These are not included in channel kits above.

514C Window clips 1.75 ea.

515C Window clips 1.75 ea.

C101 Flexible Window Glass Channel: Mohair lined, cloth covered with stainless steel bead. Fits 1933-60 2 and 4 door sedan side windows.

C101 Flexible channel (6 ft) 33.00 ea.

C202 Rigid Upper Division Bar: Mohair lined with stainless steel bead. Used on front and rear door window channel above belt line. Fits 1933-60 models in vent window frame.

C202 Upper division bar (two 18" lengths) 29.50 pr.

C303 Rigid Lower Division Bar: Mohair lined, no bead. Used on front and rear door window channel down inside door. Fits all 1940-60 models.

C303 Lower division bar (two 18" lengths) 29.50 pr.

C404 Flexible Sweeper: For inner and outer beltline, used on all cranking and sliding glass. Applies to 1933-60 all models. Specify year and inner or outer.

C404 Flexible sweeper (64" length) 29.50 ea.

6114 Mohair Channel Liner: Fits 1954-58 all holiday coupe and convertible in rear of front door glass and rear quarter window channel.

6114 Mohair Liner Sold by the foot 4.00 ft.

Front Door Window Adjuster Bumper Cushion:

This small part, when worn, is the main reason for scratched side glass. Fits 1940-58 convertible, 1949-58 holiday coupe, 1955-60 4 door holiday sedan, and 1957-58 wagon. 6 used per car.

WB408 Window cushion 2.00 ea.

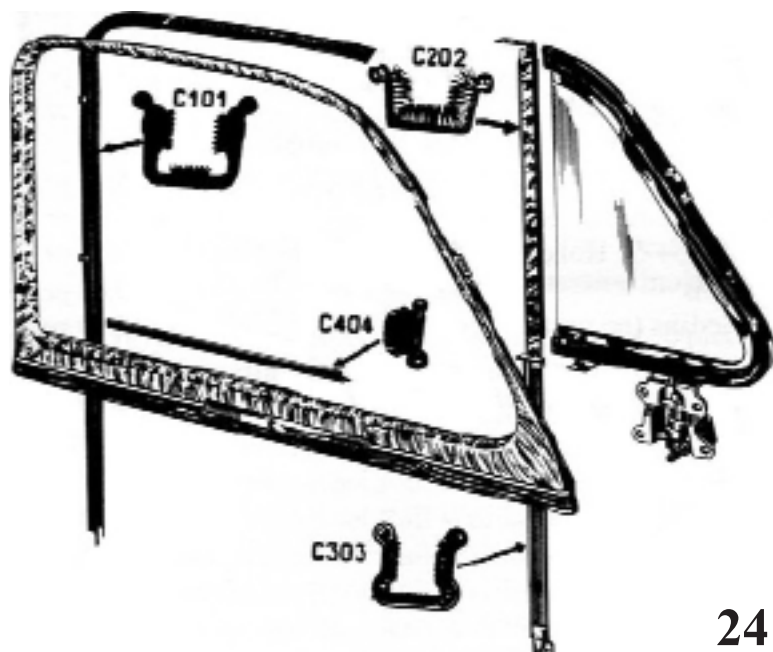

VENT WEATHERSTRIPPING



Front and Rear Vent Window Molded Weatherstrips: All Vent Window Rubber is molded to original manufacturer's specifications.

Vent Window Division Bar Vertical Seals: Cements to original metal backing. For front and rear vents on all 1934-60 Oldsmobiles. Applications available with metal core are listed below.

VS30 Vertical Vent Seals 1934-60 All 9.50 pr.



UPPER CORNER WINDOW STOP

WS518 Upper Corner Window Stop 1951-58 All Holiday Coupe and Convertible 33.00 pr.

WS590 Upper Corner Window Stop 1959-60 All Holiday Coupe and Holiday Sedan 35.00 pr.

VENT SEALS WITH STEEL CORE

VS411	Vent Seal	1941-48 66, 68 Conv., 1949 76-88 Closed, 1950 76-88 exc Holiday Cpe & Conv.	28.50 pr.
VS500	Vent Seal	1949-50 76-88 Holiday Coupe and Convertible	28.50 pr.
VS502	Vent Seal	1951-53 S88 Holiday Coupe and Convertible	28.50 pr.
VS503	Vent Seal	1950-53 98 Holiday Coupe and Convertible	28.50 pr.
VS504	Vent Seal	1954-56 All Holiday Coupe and Convertible	28.50 pr.
VS505	Vent Seal	1955-56 Holiday Sedan	28.50 pr.
VS507	Vent Seal	1957-60 Convertible, 1959-60 Holiday Coupe	28.50 pr.
VS508	Vent Seal	1957-58 Holiday Coupe	28.50 pr.
VS509	Vent Seal	1957-58 Holiday Wagon, 1957 Holiday Sedan	28.50 pr.
VS510	Vent Seal	1957 2 and 4 Door Sedan, 1957 Post Wagon	28.50 pr.
VS512	Vent Seal	1958 Holiday Sedan (4 door no post)	28.50 pr.
VS506	Vent Seal	1958 2 and 4 Door Sedan	28.50 pr.
VS511	Vent Seal	1959-60 All Convertible and Holiday Coupes	28.50 pr.

FRONT VENT WINDOW WEATHERSTRIPS

VR7	Vent Weatherstrips	1937-38 All except Convertible	103.00 pr.
VR8	Vent Weatherstrips	1937-38 All Convertibles	113.00 pr.
VR9	Vent Weatherstrips	1939 60 Series except Convertibles	103.00 pr.
VR17	Vent Weatherstrips	1941-48 66-68 except Town and Club Sedans and Convertibles	99.00 pr.
VR18	Vent Weatherstrips	1941-48 66-68 Convertibles	113.00 pr.
VR19	Vent Weatherstrips	1941-48 76-78 All Models	113.00 pr.
VR22	Vent Weatherstrips	1948-49 98 Convertible, 1949 98 Holiday Coupe	136.00 pr.
VR23	Vent Weatherstrips	1949-50 76-88 except Holiday Coupe and Convertible, 1951 88A All	109.00 pr.
VR24	Vent Weatherstrips	1949-50 76-88 Convertible, 1950 76-88 Holiday Coupe	119.00 pr.
VR24C	Vent Weatherstrips	1950-51 98 Holiday Coupe and Convertible	149.00 pr.
VR25	Vent Weatherstrips	1951 Super 88, 1952-53 All except Holiday Coupe and Convertible	113.00 pr.
VR26	Vent Weatherstrips	1951 S88, 1952-53 Holiday Coupe and Convertible	176.00 pr.
VR27	Vent Weatherstrips	1954-56 All Holiday Coupe and Convertible	123.00 pr.
VWG546	Vent Window Assembly Base Rubber Gasket	1954-56 Holiday Coupe and Convertible	39.50 pr.
VR28	Vent Weatherstrips	1954-56 All 2 and 4 Door Sedans	103.00 pr.
VR29	Vent Weatherstrips	1955-56 All 4 Door Holiday Sedans (no post)	129.00 pr.
VR30	Vent Weatherstrips	1957-58 All Holiday Coupe and Convertible	149.00 pr.
VR30A	Vent Weatherstrips	1957-58 Holiday Wagon, 1957 4 Door Holiday Sedan (no post)	149.00 pr.
VR30B	Vent Weatherstrips	1957 2 and 4 Door Sedan, 1957 Post Wagon	149.00 pr.
VR30C	Vent Weatherstrips	1958 2 and 4 Door Sedan (with post)	149.00 pr.
VR30D	Vent Weatherstrips	1958 All 4 Door Holiday Sedan (no post)	149.00 pr.
VR30E	Vent Weatherstrips	1958 All Holiday Wagon	149.00 pr.
VR31	Vent Weatherstrips	1959-60 All Convertible and Holiday Coupe	89.00 pr.
VR32	Vent Weatherstrips	1959 All 2 and 4 Door Sedan and Station Wagons	83.00 pr.
VR33	Vent Weatherstrips	1960 All 2 and 4 Door Sedan and Station Wagons	83.00 pr.

REAR VENT WINDOW WEATHERSTRIPS

VR2 Rear Vent Weatherstrips	1937-38 All 4 Door Touring Sedans (style 3619, 3819)	149.00 pr.
VR2A Rear Vent Weatherstrips	1949-50 76-88, 1951 88A 4 Door Sedan	113.00 pr.
VR2B Rear Vent Weatherstrips	1951-53 All 4 Door Sedans except 1951 88A	123.00 pr.
VR2C Rear Vent Weatherstrips	1954-56 All 4 Door Sedans except style #3669 (does not fit plain 88)	139.00 pr.

Quarter Window or Rear Window Division Rubber Channels: Fits between front and rear window and is always mounted on the leading edge of the rear window. Trim to correct length.

QW50 Quarter Window Channel
1949-60 2 Door H/T and Convertible 18.50 pr.



QW55 Rear Door Window Channel
1955-60 4 Door Hardtops & Station Wagon
19.50 pr.



Body Quarter Window Sealing Strips: With metal insert. Details upper rear body pillar jamb under quarter window.

BP546 Quarter Sealing Strip 1954-56
Holiday Coupe. 39.50 pr.

BP545 Quarter Sealing Strip 1952-56
Convertibles, 1952-53 Hol. Cpes 29.50 pr.

BP580 Quarter Sealing Strip 1957-58
Holiday Coupe. 37.50 pr.

BP581 Quarter Sealing Strip 1957-60
Convertibles. 29.50 pr.



1957-58 WINDOW DRAIN TUBES-BODY LOCK PILLAR WEATHERSTRIP

1957 All Convertible Rear Quarter Window Drain Tube: Mounted in the rear quarter of all 1957 convertibles under the rear quarter windows, these parts are often deteriorated beyond recognition. These tubes are molded with the correct oval shape and are used along with the Drain Tube Grommets. Tubes and Grommets each sold separately, in pairs.

DH57CV Quarter Window Drain Tube 1957 All Convertibles 32.00 pr.

DHG57CV Drain Tube Grommet 1957 All Convertibles 16.50 pr.

1957 All Convertibles Body Lock Pillar Molded Weatherstrip: Complicated molded rubber pillar lock seal with steel insert. These previously unavailable pieces perfectly replace original GM numbers 4695400/01. Mounted on the rear quarter under the rear window on all 1957 convertibles. Sold in pairs.

QW57BP Body Lock Pillar Molded Weatherstrip 1957 all Convertibles 65.00 pr.



1957-58 Rear Window Gutter Drain Tube: Molded rubber drain tube fits most 1957-58 models at rear window gutter area.



RWD578 Rear Gutter Drain Tube 1957-58 most models 35.00 pr.

1957-58 All Models Windshield Channel at Firewall to Fender Drain Tubes:

20" long tube with correctly molded self retaining, oval end and grommet to prevent chafing against sheet metal. Sold in pairs.

WDT578 Windshield Channel to Fender Drain Tubes 1957-58 All 35.00 pr.



CONVERTIBLE ROOF RAIL WEATHERSTRIP SETS

We have most of the pre-1961 Convertible Top Weatherstrip Sets available. All weatherstrips are sold as sets only, no single pieces. Manufactured in steel compression molds with metal reinforcements where required.

RR428 Convertible Roof Rail Weatherstrip Set (6 pieces)	1942-48 60 Series Convertible	239.00 set
RR490 Convertible Roof Rail Weatherstrips (7 pieces)	1949-50 76-88 Convertible	339.00 set
RR501 Convertible Roof Rail Weatherstrips (8 pieces)	1950-51 98 Convertible	399.00 set
RR512 Convertible Roof Rail Weatherstrips (6 pieces)	1951-52 All except 1951 98	219.00 set
RR530 Convertible Roof Rail Weatherstrips (7 pieces)	1953 Convertibles except Fiesta	269.00 set
RR546 Convertible Roof Rail Weatherstrips (7 pieces)	1954-56 All Convertible	399.00 set
RR570 Convertible Roof Rail Weatherstrips (7 pieces)	1957-58 All Convertible	359.00 set
RR590B Convertible Roof Rail Weatherstrips (7 pieces)	1959-60 88 Convertible	279.00 set
RR590C Convertible Roof Rail Weatherstrips (7 pieces)	1959-60 98 Convertible	289.00 set

WINDSHIELD, QUARTER, AND REAR WINDOW MOLDED RUBBER CHANNEL

All Windshield, Quarter, and Rear Window Channels are one-piece units molded into an endless ring. No cutting or splicing is needed during installation. Please provide your body style number to avoid confusion on the model you have. The body style number can be found on the plate riveted on the firewall, and starts with the year of the car.

PS418  **PINCHWELD SEAL:** Used to retain 1941-48 Windshield Reveal Moldings.

	PS418 Pinchweld seal	Available in 12 foot lengths.	36.50
WR103	Windshield Channel	1935-36 All except Convertible	86.00
WR103A	Windshield Divider Molded Channel	1935-36 All Models	59.00
WR104	Windshield Channel	1937-38 All except Convertible	96.00
WR104A	Windshield Divider Molded Channel	1937-38 All Models	49.00
WR105	Windshield Channel	1937-38 Convertible	83.00
WR112	Windshield Channel	1941-48 66-68 except 1942-48 Club Sedans	103.00
WR113	Windshield Channel	1941-48 76-78 All Models	136.00
WR114S	Windshield Channel	1949-50 76-88 Station Wagons with reveal molding	123.00
WR115	Windshield Channel	1949-50 76-88 Club Sedan (Fastback) 2 pc Wind.	126.00
WR116	Windshield Channel	1949-50 76-88 Club Coupe, 2 and 4 Dr Sedan 2 pc Windshield	119.00
WR117	Windshield Channel	1949-50 76-88 Holiday Coupe and Convertible 2 pc Windshield	126.00
WR118	Windshield Channel	1949-50 76-88 Club Sedan, Hol. Cpe and Conv. with 1 pc Windshield	106.00
WR119	Windshield Channel	1949-50 76-88 Club Coupe and All 2 and 4 Door Sedans with 1 piece Windshield, 1951 88A All Models	99.00
WR120	Windshield Channel	1951 Super 88, 52-53 All except Holiday Coupe and Convertibles	99.00
WR121	Windshield Channel	1951 Super 88, 52-53 All Holiday Coupe and Convertibles	99.00
WR121F	Windshield Channel	1953 98 Fiesta Convertible	219.00
WR122	Windshield Channel	1954 All, 1955-56 Convertibles	129.00
WR123	Windshield Channel	1955-56 except Convertibles	139.00
WR124	Windshield Channel	1957-58 All Convertibles & Holiday Coupe	139.00
WR125	Windshield Channel	1957-58 All except Convertibles & Holiday Coupe	136.00
WR126	Windshield Channel	1959-60 All Holiday Coupes and Convertibles	89.00
WR127	Windshield Channel	1959-60 All except Holiday Coupes and Convertibles	89.00

Rear Quarter Window Channels for 1937-41 Models with Stationary Side Windows:

RQW379	Rear Quarter Window Channels	1937-38 All Business Coupes, 1939 60 series Bus. Coupes	79.50 pr.
RQW390	Rear Quarter Window Channels	1939 70-80 series Coupes, 1940 70 series Business Coupes	79.00 pr.
RQW400	Rear Quarter Window Channels	1940 60 series Business Coupes	99.00 pr.
RQW410	Rear Quarter Window Channels	1941 66-68 series Business Coupes	99.00 pr.

REAR WINDOW CHANNELS:

RW103	Rear Window Channel	1935-36 All Sedans	79.00
RW104	Rear Window Channel	1937-38 All except Convertibles	93.00 pr.
RW105	Rear Window Channel	1939-40 60 series except Convertible	79.00
RW107	Rear Window Channel	1939-40 70-80 series, 1941-48 All except 1948 98	96.00
RW109	Rear Window Channel	1949-50 76-88 Town and Club Sedan (Fastback)	83.00
RW110	Rear Window Channel	1949-50 76-88 Club Coupes	89.00
RW111	Rear Window Channel	1949-50 76-88 2 and 4 Dr Sedans (plainback)	93.00
RW113	Rear Window Channel	1952-53 All with One Piece Rear Window	129.00
RW114	Rear Window Channel	1954-56 All Holiday Coupes	149.00
RW115	Rear Window Channel	1954-56 All 2 and 4 Door Sedans	139.00
RW116	Rear Window Channel	1955-56 All Holiday Sedans (4 door, no post)	116.00
RW117	Rear Window Channel	1957 All Holiday Coupes (3 piece set)	243.00
RW118	Rear Window Channel	1957 All except Holiday Coupe (3 piece set)	243.00
RW119	Rear Window Channel	1958 All Models except Convertibles	149.00
RW121	Rear Tailgate Window Channel	1957-58 All Station Wagons	216.00

4 Door Hardtop (no center pillar) Roof Rail Weatherstrip



Oldsmobile introduced the 4 Door Hardtop or Holiday Sedan in 1955. We have all applications available for this body style through 1960. The 1955-56 Holiday Sedan uses a very complex, expensive roof rail weatherstrip with a metal insert. We also offer an economy straight extrusion, which you can glue to your old metal core, if desired (please note that this is a difficult, cumbersome process).

RR558	Roof Rail Weatherstrips (2 six foot extruded sections without metal backing)(economy choice)	1955-56 All Holiday Sedans	69.50 pr.
RR558M	Roof Rail Weatherstrips (with metal backing)	1955-56 All Holiday Sedans	399.00 pr.
RR568A	Roof Rail Weatherstrips (with molded ends)	1957 All Holiday Sedans and 1957-58 Super 88 Station Wagon	129.00 pr.
RR568B	Roof Rail Weatherstrips (with molded ends)	1958 All Holiday Sedans	129.00 pr.
RR590A	Roof Rail Weatherstrips (with molded ends)	1959-60 Dynamic 88-S 88 Holiday Sedans	119.00 pr.
RR590D	Roof Rail Weatherstrips (with molded ends)	1959-60 98 Holiday Sedans	119.00 pr.

2 Door Hardtop (Holiday Coupe) Roof Rail Weatherstrip



For 1950 Holiday Coupes we offer both types of Roof Rail Weatherstrips. The 1st type extends the full length of the roof. The 2nd type extends only to the rear of the door. Holiday Coupes not listed used a "Flipper Molding" which is not available.

RR50	Roof Rail Weatherstrip (1st type)	1950 76-88 Holiday Coupes	289.00 pair
RR50A	Roof Rail Weatherstrip (2nd type)	1950 76-88 Holiday Coupes	239.00 pair
RR578M	Roof Rail Weatherstrip	1957-58 88 Holiday Coupes	129.00 pair
RW59	Roof Rail Weatherstrip	1959-60 Holiday Coupes	119.00 pair
RR546HT	Flipper Molding End Weatherstrip	1954-56 All Holiday Coupes	46.00 pair
RP578HC	Flipper Molding Mounting Pad	1957-58 All S88-98 Holiday Coupes	11.00 pair

Windshield Pillar Post Weatherstrip

These pillar post weatherstrips fit all 1949-50 Convertibles, 1954-60 Convertibles, Holiday Coupe and Holiday Sedans vertically on the windshield post. Trim and cement in proper location.

WP49	Windshield Pillar Weatherstrips	1949-50 76-88 Convertibles	89.00 pr.
WP95S	Windshield Pillar Weatherstrips (with pins)	1954-58 Conv., HC, HS	39.00 pr.
WP95	Windshield Pillar Post Weatherstrip	1954-58 Conv., HC, HS	16.50 pr.
WP59	Windshield Pillar Weatherstrips	1959-60 Conv., HC, HS	89.00 pr.



Molded Door Weatherstrip



1949-60 Door Weatherstrips are now available as tab inserted (where applicable) sponge rubber with molded ends and corners. Holiday Sedan models are 4 door hardtops, Sedan models are 4 door post, and Holiday Coupe is a 2 door hardtop (no post). See diagram on following page. The price of these weatherstrips reflects the complexity of the molded ends and corners. The correct configuration weatherstripping is also available by the foot on page 31.

2 Door Hardtop and Convertible Door Weatherstrip

DW49	Door Weatherstrips	1949-50 76-88 Hol Cpe & Conv. (glue on with molded ends)	149.00 pr.
DW51	Door Weatherstrips	1951-53 Holiday Coupe and Convertible, exc 1951 98 (glue on)	219.00 pr.
DW54	Door Weatherstrips	1954, 1955 1st type Holiday Coupe and Convertible (glue on)	123.00 pr.
DW56	Door Weatherstrips	1955 2nd type, 1956 All Holiday Coupe and Conv. (push in tab)	123.00 pr.
DW58	Door Weatherstrips	1957-58 All Holiday Coupe and Convertible (push in tab)	123.00 pr.
DW59	Door Weatherstrips	1959-60 All Holiday Coupe and Convertible (push in tab)	93.00 pr.

2 Door Sedan (with post), 4 Door Holiday Sedan (no post) and 4 Door Sedan (with post) Door Weatherstrip

DW50F	Front Door Weatherstrips	1949-50 76-88, 1951 88A 4 Door Sedan (with post)(glue on)	143.00 pr.
DW50R	Rear Door Weatherstrips	1949-50 76-88, 1951 88A 4 Door Sedan (with post)(glue on)	116.00 pr.
DW54F	Front Door Weatherstrips	1954-56 4 Door Sedans (with post)(glue on)	89.00 pr.
DW54R	Rear Door Weatherstrips	1954 4 Door Sedans (with post)(glue on)	119.00 pr.
DW55F	Front Door Weatherstrips	1955-56 4 Door Holiday Sedan (no post)(glue on)	119.00 pr.
DW55R	Rear Door Weatherstrips	1955-56 4 Door Holiday Sedan (no post)(glue on)	119.00 pr.
DW556R	Rear Door Weatherstrips	1955-56 4 Door Sedan (with post)(push in tabs)	89.00 pr.
DW57F	Front Door Weatherstrips	1957-58 4 Door Holiday Sedan, and Wagon (no post)(push in tabs)	119.00 pr.
DW57R	Rear Door Weatherstrips	1957 4 Door Holiday Sedan, and Wagon (no post)(push in tabs)	119.00 pr.
DW58S	Door Weatherstrips	1958 2 Door Sedan (with post)(push in tabs)	99.00 pr.
DW58R	Rear Door Weatherstrips	1958 4 Door Holiday Sedan and Wagon (no post)(push in tabs)	119.00 pr.
DW58SF	Front Door Weatherstrips	1958 4 Door Sedan (with post)(push in tabs)	139.00 pr.
DW58SR	Rear Door Weatherstrips	1958 4 Door Sedan (with post)(push in tabs)	109.00 pr.
DW59F	Front Door Weatherstrips	1959-60 4 Door Sedan and Wagons (with post)(push in tabs)	109.00 pr.
DW59R	Rear Door Weatherstrips	1959-60 4 Door Sedan (with post)(push in tabs)	109.00 pr.
DW59HF	Front Door Weatherstrips	1959-60 D88-S88 4 Door Holiday Sedan (no post)(push in tabs)	109.00 pr.
DW59HR	Rear Door Weatherstrips	1959-60 D88-S88 4 Door Holiday Sedan (no post)(push in tabs)	109.00 pr.



1954-60 All Models Auxiliary Door Hinge Weatherstrip: For all 1954-60 Models on front portion of front door. This is the J shaped rubber piece that loops under the top door hinge. Cement in place. Comes with alignment pins.

DW90	Auxiliary Door Weatherstrips	1954-56 All Models	33.50 pr.
DW90A	Auxiliary Door Weatherstrips	1957-58 All Models	33.50 pr.
DW90B	Auxiliary Door Weatherstrips	1959-60 All Models	33.50 pr.

Body Style Description

The following illustrations show 4 of the 6 major body styles used by Oldsmobile in the 40's and 50's. Convertibles and Station Wagons are not shown. When ordering parts it is essential to accurately describe your car. Body style is especially important when ordering weatherstripping. Please use the illustrations to identify your body style.



Holiday Coupe or 2 Door Hardtop.
No post when door and rear quarter windows are rolled down.

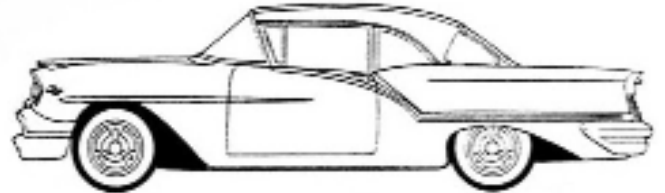

2 Door Sedan, or Post Coupe Has a post all around the door and rear window glass. Post stays when windows are rolled down.

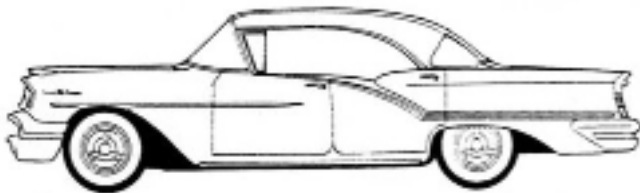

Holiday Sedan or 4 Door Hardtop.
No post when both side windows are rolled down.

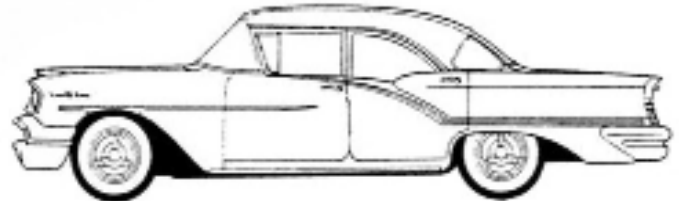

Sedan or 4 Door Sedan. Has post all around both side door windows. Post stays when windows are rolled down.

Door Bottom Drain Hole Seals



Seal for door bottom drain hole in all models. Usually 2 used per door. Also used in the bottom of the tailgate on 1957-58 Station Wagons.



DHS578	Door Bottom Drain Hole Seal	1957-58 All models	4.50 ea.
DHS591	Door Bottom Drain Hole Seal	1959-60 All models	4.50 ea.

Fender Skirt Rubber



Skirt Rubber for 1941 through 1960 Models. 9 foot length supplied. Skirt Rubber must be cut for fender skirt tabs where needed. Cross sections of rubber pictured to the left.

FS4	Fender Skirt Rubber	1941-48 All models except 1948 98	29.50
FS5	Fender Skirt Rubber	1948 98, 1949-55 All except 1951-53 S88	29.50
FS6	Fender Skirt Rubber	1951-53 Super 88 and 88 models	29.50
FS7	Fender Skirt Rubber	1956-60 all models with Foxcraft skirts	21.50 pr.

Rear Gravel Deflector Rubber



Rear Gravel Deflector Rubber. Used as an insulator between rear bumper and gravel deflector.

GDR490	Gravel Deflector Rubber (3 pc die cut)	1949-50 76-88, 1951 88A	23.00
GDR493	Gravel Deflector Rubber (8 ft section)	1950 98, 1951 S88-98, 1952-53 All	26.50

3/16" Beaded Fender Welt

Used on all 1928-48 models, and 1949-53 98's. Order by the foot or in economical rolls.

FW100	Fender Welt	1.00 per foot
FW100A	Fender Welt 25 ft roll	18.00 per roll
FW100B	Fender Welt 50 ft roll	30.00 per roll



1950 76-88, 1951 88A Steering Column Black Rubber Filler: Fits 1950 76-88, 1951 88A, used as an anti-squeak seal between dash and column.

SCF50	Steering Column Filler	1950-51 All	19.50
--------------	------------------------	-------------	-------



1950 76-88 Models Steering Column Rubber Grommet: Used on 1950 76 & 88 models only, Located on column to floor board. Black only. Inner Felt washer inside grommet not included.

SCG50	Steering Column Grommet	24.50
--------------	-------------------------	-------



1957 Oldsmobile Tail Light Mounting Bead:

An essential detail item for all 1957 Oldsmobile restorations. This is a paint line weatherstrip only, and does not install the entire perimeter of the tail light assembly.

TLB57	Mounting Bead	1957 All models	22.00 pr.
--------------	---------------	-----------------	-----------



Deluxe Steering Wheel Horn Button Rubber

Cushion: An important part for proper horn operation. These cushions become brittle with age and are a possible cause of inadvertent horn operation.

562694	Cushion 1953-54 All with Deluxe Wheel	14.50
566369	Cushion 1955-56 All with Deluxe Wheel	14.50
569764	Cushion 1957 All with Deluxe Wheel	14.50

1949-53 All Models Fresh Air Rubber Sleeve: For all 1949-53 models. Uses two or 3 sleeves per car.

FAS493	Fresh Air Sleeve	1949-53 All	19.50 ea.
---------------	------------------	-------------	-----------

Gas Filler Neck Grommets:

GF35	Grommet	1935 all	35.00
GF63	Grommet	1936 all	23.50
GF73	Grommet	1937 all	24.50
GF83	Grommet	1938 All	24.50
GF93	Grommet	1939 all, 1940 60-70 Series	27.50



Cowl Vent Gaskets:

New exact copy of the original part. Prevents water and air leaks and adds detail to cowl area.

CV356	Vent Gasket	1935-36 All	22.00
CV378	Vent Gasket	1937-48 All	22.00



MOLDED RUBBER WEATHERSTRIPPING

Outstanding quality extruded black closed cell sponge rubber weatherstrip used on all 1935-60 Models. Molded extruded rubber (solid) applies to pre 1940 Oldsmobiles. All extruded weatherstrips are a glue-on design. Molded one piece door weatherstrips are located on page 28-29. Many models from 49-53 use a split trunk weatherstrip, which has one piece in the body gutter across top of trunk opening and the remainder on the trunk lid. Please watch applications carefully.

DOOR WEATHERSTRIP

DW55 All 1935-36 Models on door top only 4.00 ft.



DW85A 1955-60 Models using push-in tab type. Used where molded ends are not available.



DW85A Door W/Strip 3.00 ft.



DW60 All 1936-39 Models on door bottom only.

DW60 Door W/Strip 3.90 ft.

TRUNK WEATHERSTRIP

TW20 Trunk weatherstrip for all 1936-39 Coupes & Convertibles Black Sponge.



TW20 Trunk W/Strip 3.00 ft.

DW65 1937-39 All Models. DW70 can be used as substitute for DW65 if desired.



DW65 Door W/Strip 3.50 ft.

DWC73 Clip for DW65 1.50 ea.

TW25 1937-39, 1940 70 series 2 & 4 Door Sedans, available in 15 foot lengths.



TW25 Trunk W/Strip 48.50 lgth.

DW70 1937-48 All except 1948 98, on top and sides of door.

DW70 Door W/Strip 3.00 ft.

TW35 Trunk weatherstrip for All 1940-48 models except 1948 98 and TW45 Applications.



TW35 Trunk W/Strip 3.00 ft.

DW75 Fits 1948 98, and most 1949-53 models.



DW75 Door W/Strip 3.00 ft.

TW45 Trunk weatherstrip for 1942-47 98, 1941-48 Fastback (Club Sedan), available in 15 foot lengths only.



TW45 Trunk W/Strip 59.00 lgth.



Body Hinge Pillar to Door Sealing Strips: Die cut original material with thread reinforcement. Fits 1949-50 76-88 & 1951 88A. Sold in pairs. **FS491** 28.50 pr.

DW80 1951-55 Models not using DW75 or DW85A door weatherstrip.



Check your door for proper usage.

DW80 Door W/Strip 3.00 ft.

3M Weatherstrip Adhesive:

Black rubber to metal cement supplied by 3M. Sold in a 5oz. tube.



8008 3M Adhesive 8.50 tube



TW48 Trunk weatherstrip for all 1948 98 models on trunk lid.



TW48 Trunk W/Strip 3.00 ft.

TWL50 Trunk weatherstrip for 1949-50 76-88, 51 88A in trunk gutter. Usually 6 ft. per car.



TWL50 Trunk W/Strip 3.50 ft.

Trunk weatherstrip for all 1949-51 98, 1952-53 models in gutter.

TWL50A Trunk W/Strip 3.50 ft.

TWU66 Trunk weatherstrip for 1949-51 All, 1952-53 S88-88, and all 1954-56 models on trunk lid. 1949-53 cars use 9 ft per car. 1954-56 cars use 18 ft per car.



TWU66 Trunk W/Strip 3.00 ft.

TWU70 Trunk weatherstrip for all 1952-53 98 models on trunk lid. Requires 9 ft. per car.



TWU70 Trunk W/Strip 3.75 ft.

TWL75A Trunk weatherstrip for all 1957-60 models, requires 18 ft. per car. Molded to fit into channel around perimeter of trunk.



TWL75A Trunk W/Strip 2.50 ft.

MECHANICAL REBUILDING SERVICES

We offer rebuilding services on these increasingly difficult to locate primary mechanical parts. All individual services require that your existing part or parts (commonly called cores) be shipped complete and unaltered for rebuilding. If you do not send a core in advance, we will require a core charge. Please do not disassemble old units. Cores with missing or broken parts will be assessed a deduction in core refund or rejected and returned.



Carburetors: Cosmetically restored exterior with new internal parts. Most 1949-60 Rochester 2 & 4 barrel carburetors are in stock. **Core charge** for 2 barrel is **175.00**, and **295.00** for 4 barrel units. Rebuilding available for Carter or Rochester 1, 2 & 4 barrels not listed with a 6-8 week lead time.

RC4902V	1949-50 8 cylinder Rochester 2V	399.00			
RC523	1952-53 Roch. 4V Manual Brake	449.00	RC5602V	1956Rochester 2V	399.00
RC530	1953 Rochester 4V Power Brake	449.00	RC570	1957 Rochester 4V	449.00
RC545	1954-55 Rochester 4V	449.00	RC580	1958 Rochester 4V	449.00
RC560	1956 Rochester 4V	449.00	RC590	1959-60 Rochester 4V	449.00

Fuel Pumps: Dual-action vacuum and fuel combination. **Core charge** on all 1937-60 Pumps is **125.00**. Rebuilding cost for each pump rebuild is **95.00**. Missing or broken glass fuel bowls will be charged 20.00 off the core refund.

523	1937-38 All	536	1941-48 6 Cylinder	4540	1957 no Glass Bowl, 1958 with Air
523	1939-40 6 Cylinder	9294	1949-54 8 Cylinder	4646	1957 with Glass Bowl, 1958 exc. A/C
516	1939-40 8 Cylinder	9297	1949-50 6 Cylinder	4727	1959-60 All without Air Conditioning
535	1941-48 8 Cylinder	4317	1955-56 All	4728	1959-60 All with Air Conditioning



Windshield Wiper Vacuum Motors: (no electric): **Core charge** for wiper motor is **60.00**. Each wiper motor rebuild service is **98.00**. Vacuum wiper motors not listed can be rebuilt using your old one. 1954 & 1956 both used 2 different designs which are very similar to each other. On these it is best to send in your core so we can match it up with the correct rebuilt wiper motor.

4573747	1949-50 76-88, 1951 88A	4649022	1954 2nd, 55 All, 56 1st
4609720	1952-53 All except Fiesta	4687069	1956 2nd type, 1957 All
4221497	1953 Fiesta, 1954 1st type	4749829	1958 All



1939-60 Water Pumps: **Core charge** for rebuilt water pumps is **60.00**. No core needed on W993A water pump. All water pumps are shipped with new gasket.

W992A	1939-41 6 Cylinder, 1942-48 All except 1948 98	Rebuilt Water Pump	129.00
W994A	1954-60 8 Cylinder with Air Conditioning	Rebuilt Water Pump	119.00
W993A	1949-60 8 Cylinder without Air Conditioning	Water Pump	89.50



1934-60 Engine Oil Pump Assembly: New internal parts and gears for all 1934-60 models. **Core charge** for oil pumps is **65.00**. We need 557162 1934-50 Oil Pump Cores.

557162	Engine Oil Pump	1934-36 6 Cyl., 1937-48 All, 1949-50 6 Cyl.	145.00
557934	Engine Oil Pump	1949-58 8 Cylinder (NEW, no core charge)	109.00
575006	Engine Oil Pump	1959-60 All Models (NEW, no core charge)	109.00



1953-60 Harmonic Balancers: Revulcanized using the latest silicon polymers. Cleaned and repainted, Each balancer (1,2, or 3 groove) is 179.00 to rebuild. We will require your old balancer to be shipped in advance to us for rebuilding. Allow 3-4 weeks lead time.

HBR536	1953-60 Harmonic Balancer Rebuild Service	179.00
---------------	---	--------



Power Brake Unit Rebuild Kits: Rebuild kits are now available for 1955-59 Moraine Power Brake units and 1953-59 Bendix Power Brake Units, commonly called Treadle-Vac. Kits include all seals and gaskets needed to rebuild your brake unit. Rubber push rod boot sold separately.

MPBK559	Moraine Power Brake Kit	1955-59	99.00 kit
BPBK539	Bendix Power Brake Kit	1953-59	63.00 kit
BPRB539	Power Brake Push Rod Rubber Boot	1953-59	19.00



BRAKE PARTS

Wheel Cylinders: Often frozen or leaking. Replace your old wheel cylinders with new ones.

6090	Left Front Wheel Cylinder	1937-41 All, 1949 88, 1950-56 All	47.50
6091	Right Front Wheel Cylinder	1937-41 All, 1949 88, 1950-56 All	47.50
7536	Left Front Wheel Cylinder	1942-48 All, 1949 98, 1949-50 76	49.50
7537	Right Front Wheel Cylinder	1942-48 All, 1949 98, 1949-50 76	49.50
7563	Left Rear Wheel Cylinder	1942-48 All, 1949 98, 1949-50 76	49.50
7564	Right Rear Wheel Cylinder	1942-48 All, 1949 98, 1949-50 76	49.50
4801	Left Rear Wheel Cylinder	1949 88, 1950-53 All	47.50
4802	Right Rear Wheel Cylinder	1949 88, 1950-53 All	47.50
13387A	Left Rear Wheel Cylinder	1954-55 All (requires adapter which is included)	49.50
13388A	Right Rear Wheel Cylinder	1954-55 All (requires adapter which is included)	49.50
13387	Left Rear Wheel Cylinder	1956-60 All	47.50
13388	Right Rear Wheel Cylinder	1956-60 All	47.50
24800	Left Front Wheel Cylinder	1957-58 All	47.50
24801	Right Front Wheel Cylinder	1957-58 All	47.50
32071	Left Front Wheel Cylinder	1959-60 All	47.50
32072	Right Front Wheel Cylinder	1959-60 All	47.50



Wheel Cylinder Kits: Use these when complete cylinders are not available or needed.

3600	Front and Rear Wheel Cylinder Kit	1934-36 All	9.75 ea.
19386	Front Wheel Cylinder Kit	1937-41 All	9.75 ea.
3600	Rear Wheel Cylinder Kit	1937-48 All, 1949 98, 1949-50 76, 1959-60	9.75 ea.
13620	Front Wheel Cylinder Kit	1942-48 All, 1949 98, 1949-50 76, 1959-60	9.75 ea.
19386	Front Wheel Cylinder Kit	1949 88, 1950-58 All except 1950 76	9.75 ea.
3608	Rear Wheel Cylinder Kit	1949 88, 1950-53 All except 1950 76	9.75 ea.
19325	Rear Wheel Cylinder Kit	1954-58 All	9.75 ea.



1939-56 Complete Manual Brake Master Cylinders and Rebuild Kits: Brand new master cylinders are available for cars with manual brakes. No power brake master cylinders or booster units available at this time

4363	NEW Master Cylinder Assembly	1939-56 All with Manual Brakes	135.00
3626	Master Cylinder Overhaul Kit	1939-56 All with Manual Brakes	19.50



1941-60 Brake Shoes:

577277	Front Brake Shoe Set	1942-48 78-98 series (GM NOS)	49.50 set
228RR	Front Brake Shoe Set	1941 76-78-96-98, 1942-50 66-68-76	55.00 set
160RR	Front Brake Shoe Set	1949-60 All 8 Cylinder	55.00 set
228RR	Rear Brake Shoe Set	1941 76-78-96-98, 1949-60 All 8 Cylinder	55.00 set



Brake Hardware: Springs, adjusters, and hold downs lose their tension. Kits available only for the cars listed.

BRS304	Brake Return Spring Set (4 wheels)	1942-60 All Front and Rear	35.00 set
BHD412	Brake Hold Down Kit (2 wheels)	1942-55 All Front	16.75 kit
BHD417	Brake Hold Down Kit (2 wheels)	1942-56 All Rear, 1956-58 All Front	16.75 kit
BHD409	Brake Hold Down Kit (2 wheels)	1957-58 All Rear	16.50 kit
BHD412	Brake Hold Down Kit (2 wheels)	1959-60 All Front	16.75 kit
BHD418	Brake Hold Down Kit (2 wheels)	1959-60 All Rear	16.50 kit
BHS562	Brake Adjuster Screw Assembly	1942-60 All Front and Rear	19.50 ea.
BHS503	Brake Adjuster Spring	1942-60 All Front and Rear	4.50 ea.



Brake Hoses:

4497	Front Brake Hose	1934-36 All	39.50 ea.
4497	Rear Brake Hose	1934-36 All	39.50
7600	Front Brake Hose	1937-38 All	39.50 ea.
7600	Rear Brake Hose	1937-38 All	39.50
5931	Front Brake Hose	1939-55 All	33.50 ea.
6560	Rear Brake Hose	1939-40 All	43.50
4497	Rear Brake Hose	1941-53 All	36.50
25629	Rear Brake Hose	1954-55 All	39.50
24058	Front Brake Hose	1956-60 All	33.50 ea.
36501	Rear Brake Hose	1956-60 All	43.50
PBH537	*Master Cylinder Brake Hose		
	1953-57 All with Power Brakes		43.50
	*Differs in appearance from original.		



PBH537

Brake Hole Adjuster Cover: original part for all 1934-60 Oldsmobiles. Sold in a pack of four.

C3460 Brake Adjuster Covers 6.00 pkg.

Brake Vacuum Hose & Clamps:

H6 Original Vacuum Brake Hose Clamp 4.50 ea.

H1451 Brake System Vacuum Hose 3.50 ft

405999 Front Wheel Dust Cap
1939-56 All 14.50 ea.



Manual Brake Stop Light Switches:

SLS24 Stop Light Switch 1934-39 All 19.50

SLS27 Stop Light Switch 1940-50 All 19.75

SLS40 Stop Light Switch 1951-58 All with Manual Brakes 23.50

Emergency/Parking Brake Cables: 1949 thru 1960 Emergency/Parking Brake Cables. Manufactured to original specifications with the correct ends and connections on cables. Correct sheathing on cables where required.

Front Brake Cables

1642	1949 76-88	69.50
1673	1950 76-88, 1951 88A	69.50
1819	1951 S88, 1952-53 All	69.50
1922	1954 98, 1955 All	69.50
1990	1956-58 All	69.50
2047	1959-60 All	69.50

Rear Brake Cables

1640	1949-50 76-88, 1951 88A	63.00 ea.
1821	1951 S88, 1952-53 88-S88	63.00 ea.
1835	1952-53 98	63.00 ea.
1900	1954-55 98	63.00 ea.

Rear Brake Cables (continued)

1899	1954-55 88-S88 (2 cable type)	63.00 ea.
1956	1956 88-S88 (2 cable type)	63.00 ea.
1959	1956 98 (1 cable type)	95.00
1957	1956 98 (2 cable type)	63.00 ea.
1986	1957-58 88-S88 exc. Convertible and 1958 Air Ride	63.00 ea.
1987	1957-58 88-S88 Convertible	63.00 ea.
1988	1957-58 98 exc Convertible & A.R.	63.00 ea.
1989	1957 98 Convertible	63.00 ea.
2016	1958 88-S88 with Air Ride	63.00 ea.
2048	1959-60 All	63.00 ea.

SPEEDOMETER CABLES:

1939-60 Complete Speedometer Cable and Casing with correct steel braided casing.

CC1	Speedometer Cable and Casing 1939-60 exc. 41-48 Hydramatic	38.50
CC7	Speedometer Cable and Casing 1941-48 with Hydramatic	39.50



IGNITION AND ELECTRICAL PARTS

Points

DR2236P	Point Set	1937-55 All	23.50
D106PS	Point Set	1956-60 All	23.50

Condensers

D203	Condenser	1937-55 All	7.50
D204	Condenser	1956-60 All	7.50

Rotors

DR158	Rotor	1937-50 6 Cylinder	9.50
DR142	Rotor	1937-50 8 Cylinder	9.50
DR306	Rotor	1951-53 All	9.50



DR309 Rotor 1954-55 All 9.50
D426R Rotor 1956-60 All 8.50

Distributor Caps

DR413	Cap	1937-50 6 Cylinder	19.50
DR196	Cap	1937-50 8 Cylinder	19.50
DR427	Cap	1951-55 All	19.50
D308R	Cap	1956-60 324-371 V8	19.50
D310R	Cap	1959-60 394 V8	19.50

TUNE-UP KITS: Consists of points, condenser, rotor and distributor cap.

TK1	Tune-up Kit	1937-50 all 6 cylinder	46.50
TK2	Tune-up Kit	1937-50 all 8 cylinder	46.50
TK3	Tune-up Kit	1951-53 all	46.50
TK4	Tune-up Kit	1954-55 all	46.50
TK5	Tune-up Kit	1956-58 all, 1959-60 371 V8	46.50
TK5A	Tune-up Kit	1959-60 394 V8 (uses special cap)	49.50



SPARK PLUGS: A.C. Delco type.

C86	Spark Plug	1928-36 all	3.50 ea.
R45	Spark Plug	1937-48 all, 1949-50 6 cylinder	3.00 ea.
R45	Spark Plug	1949-54 8 cylinder	3.00 ea.
R43	Spark Plug	1955-60 all	3.00 ea.



1937-60 IGNITION WIRE SETS AND SPARK PLUG WIRE HOLDERS:

1954-60 Delco-Packard tailored wire sets, 1937-48 semi-tailored black lacquered cloth wire sets, and 1949-60 semi tailored rubber wire sets.

RS214	Lacquered Cloth Wire Set	1937-50 all 6 cylinder	36.50 set
RS215	Lacquered Cloth Wire Set	1937-48 all 8 cylinder	39.50 set
RS240R	Rubber Wire Set	1949-60 all	39.50 set
RS260D	Reproduction Delco-Packard Wire Set	1954-56 all	89.50 set
RS270D	Reproduction Delco-Packard Wire Set	1957-58 all	89.50 set
RS280D	Reproduction Delco-Packard Wire Set	1959-60 all	89.50 set
WH490	Single Spark Plug Wire Holder	1949-50 all (up to 12 per car)	1.50 ea.
WH518	4 Spark Plug Rubber Wire Holder	1951-60 all (up to 4 per car)	5.00 ea.



1940-48 8 Cylinder NOS Distributor Assembly:

We have located a supply of New Old Stock 1940-48 8 Cyl. Distributors. Comes complete with vacuum advance, NEW cap, rotor, points and condenser.

1110808	NOS Distributor Assembly	1940-48 8 Cyl.	128.00
----------------	--------------------------	----------------	--------

FACTORY REBUILT DISTRIBUTORS

All Distributors for 1949-60 Oldsmobile V8's in stock for immediate shipment. **Core charge of 100.00 on all distributors.** Rebuilt distributor includes vacuum advance, points, condenser, rotor and distributor cap. On 1956-60 specify with or without oil tube.

849	Rebuilt Distributor	1949-50 all V8	149.00
851	Rebuilt Distributor	1951-55 all	149.00
900	Rebuilt Distributor	1956-58 all	149.00
903	Rebuilt Distributor	1959-60 all	149.00



REBUILT DISTRIBUTOR VACUUM ADVANCES:

We now have the Distributor Vacuum Advance available for 1949-60 V8 All models. These are rebuilt units and require a **core charge of 35.00.**

VA849	Distributor Vacuum Advance	1949-50 8 cyl. Models	49.50
VA851	Distributor Vacuum Advance	1951-55 All Models	49.50
VA900	Distributor Vacuum Advance	1956-58 All Models	49.50
VA903	Distributor Vacuum Advance	1959-60 All Models	49.50



1948-60 IGNITION COIL AND BALLAST RESISTOR

337164	6 Volt Ignition Coil (current Delco)	1948-52 All	49.50
337166	12 Volt Ignition Coil (current Delco)	1953-60 All	49.50
1957154	Ignition Ballast Resistor	1954-60 All	36.50



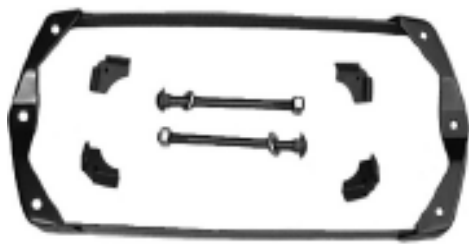

BATTERY HOLD-DOWNS AND ATTACHING PARTS

Most original hold-downs have either been discarded or have deteriorated over the years from battery acid. We have die-stamped the correct battery hold-downs for all 1949-60 models except 1953 which is unique. These hold-downs were very expensive to manufacture, however, we felt there was a need for correct detail under the hood in the battery area. All hold down parts are sold separately. Picture shown is for 1957-59 models.

556023	Battery Hold-down (2 piece unit with battery cap cover)	1949-52 all (10" X 7 3/8")	49.50
567046	Battery Hold-down (includes brace)	1954-56 all (13 1/4" X 6 1/2")	38.00
568900	Battery Hold-down (pictured above)	1957-59 all (13 1/4" X 6 3/4")	39.50
HD6201	Battery Hold-down	1960 all	24.00
BK10643	Hold-down Nuts, Bolts, Washers (cut to fit)	1949-56 all	11.00
BK579	Hold Down-kit (includes nuts, bolts, washers)	1957-58 all	11.00

Battery Cable Boot

Cover: Fits all 1954-60 models. Usually missing or destroyed.



SCC46 Cable Boot 8.50

Rubber Battery

Cable Cover at Positive Battery Post: Applies to all

1931-60 models.



BCC36 Cable Cover 8.50

Battery Hold-down Rubber End

Cushions: Fits all 1957-59 models. 4 cushions per car.



BHC54 Cushions 5.00 ea.

1949 & 1950 8 Cylinder Valve Cover Ignition Wire Covers: New reproductions of the stamped metal plates that bolt onto the top of the valve covers and retain the Ignition Wires. 1949 cover is silver with the 'Oldsmobile Rocket' in red. 1950 cover is gold with red printing.

VCP49 1949 Silver Valve Cover Plate 1949 V8 engines 49.50 pair

VCP50 1950 Gold Valve Cover Plate 1950 V8 engines 49.50 pair



POSITIVE BATTERY CABLES AND NEGATIVE STRAPS:

For 1934-60 Oldsmobiles. All applications are the correct color cable and use the correct gauge cable. All 1954-60 models used two section positive battery cables.

Positive Battery Cables

SA58	1934-37 all	37.50
SA17	1938-48 all	29.75
SA27	1949-50 6 cylinder	33.50
SA38	1949-52 8 cylinder	44.50
26735	1953 all	39.50
23720	1954 all (junction block to starter)	46.50
26740	1954 all (battery to junction block)	36.50
26700	1955 all without A/C (junction block to starter)	46.50
23600	1955 all without A/C (battery to junction block)	37.50
23685	1956-58 all without A/C (junction block to starter)	46.50
23690	1956-58 all with A/C (junction block to starter)	46.50
23345	1956-58 all with A/C (battery to junction block)	36.50
23695	1956 all without A/C (battery to junction block)	39.50



23700 1957 all without A/C 39.50

(battery to junction block)

23345 1958 all without A/C 36.50

(battery to junction block)

26710 1959-60 all 47.50

(junction block to starter)

26890 1959-60 all 37.50

(battery to junction block)

Negative Ground Straps

7230300 1938-58 Engine to Cowl Strap 13.50

38119 1952-53 98 & Fiesta top motor to 25.50
cowl brace ground strap

G9 1934-37 all 35.00

SA24 1938-40 all 35.00

G17 1941-52 all 33.50

G19 1953 all 33.50

01707 1954-56 all 39.50

23365 1957-58 all 39.50

23360 1959 all 39.50

23350 1960 all 36.50

STARTER AND GENERATOR ARMATURES:

GM New Old Stock Starter Armatures available for 1934-38 All models and Generator Armatures are available for 1934-51 All models.

823881	Starter Armature	1934-38 All Models	49.50
1871826	Generator Armature	1934-39 All Models	53.50
1867897	Generator Armature	1940-51 All Models	58.50



STARTER SOLENOID SWITCHES:

GM New Old Stock for 1949-52 and 1957-60, New units available for 1954-56.

1118156	Starter Solenoid Switch (NOS GM)	1949-52 All	54.50
SS201	Starter Solenoid Switch (New)	1954-56 All	64.50
D969	Starter Solenoid Switch (NOS GM)	1957-60 All	39.50



STARTER DRIVE ASSEMBLIES:

New Old Stock Starter drives available for 1939-53 All models and NEW Starter Drives for 1954-60 All models.

1873789	Starter Drive Assembly (NOS)	1939-53 All	39.50
SDN1A	Starter Drive Assembly (New)	1954-56 All	37.50
SDN8	Starter Drive Assembly (New)	1957-60 All	37.50



Starter Solenoid Plunger Boot: Rubber boot used on all starter solenoids from 1949-56. Replaces dried out or cracked original boot. **SPB567** Starter Solenoid Plunger Boot 1949-56 All 9.50



STARTER AND GENERATOR BRUSH SETS:

Necessary maintenance item for any rebuilding process. Each brush set will service one unit.

RX60	Starter Brush Set	1932-52, 1954-60 all	8.50
RX45	Starter Brush Set	1953 all	8.50
RX51	Generator Brush Set	1940-51 all	8.50
RX58	Generator Brush Set	1952-53 all	8.50
RX63	Generator Brush Set	1954-60 all	8.50
3203	Generator End Bearing	1936-60 all	14.50



DIMMER SWITCH, VOLTAGE REGULATORS, AND HORN RELAYS

We use Delco parts whenever possible. If another brand is used it is the best available replacement.

DS40	Headlight Dimmer Switch	1936-58 all	19.50
HR114	Horn Relay (Standard)	1937-52 all	23.50
U1738	Horn Relay (Delco)	1953-57 all	27.50
D601	Voltage Regulator	1940-52 all	89.50
D618	Voltage Regulator	1953-56 all, 1957 without A/C	89.50
VR24R	Voltage Regulator (Standard)	1957 with A/C, 1958-60 all	89.50

ENGINE GASKET SETS

Includes head, oil pan, rocker cover, valve cover, timing cover, intake and exhaust manifold gaskets, and main bearing seals. *Includes a rubber rear main seal.

RS516C	Gasket Set	1937-48 6 cylinder	169.00
RS530C	Gasket Set	1949-50 6 cylinder	179.00
RS560C	Gasket Set	1937-48 8 cylinder	169.00
RS566S	Gasket Set	1949-53 8 cylinder	169.00
RS566SX	Gasket Set	1954-56 all	179.00
RS512S	*Gasket Set	1957-58 all	189.00
RS513S	*Gasket Set	1959-60 all	189.00

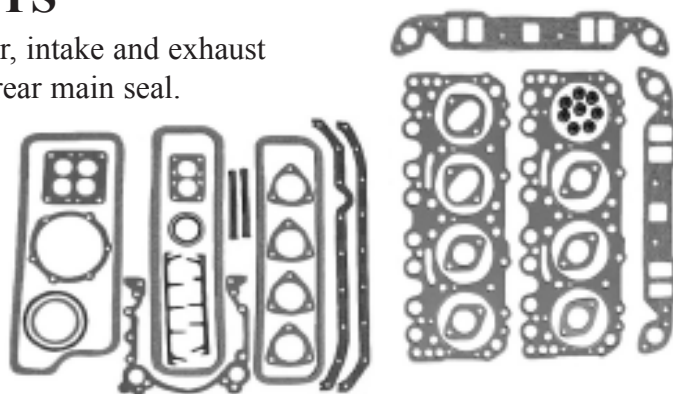

INDIVIDUAL GASKET SETS:

6412	Oil Pan Gasket Set	1949-56 8 cylinder	26.50
6412A	Oil Pan Gasket Set	1957-58 8 cylinder	26.50
6412B	Oil Pan Gasket Set	1959-60 8 cylinder	26.50
13008	Side Cover Gasket	1939-50 6 cylinder	13.50
16008	Side Cover Gasket	1939-48 8 cylinder	18.00
6405	Push Rod Cover Gasket (valley pan)	1949-58 8 cylinder	16.50
PS12420R	Push Rod Cover Gasket (valley pan)	1959-60 8 cylinder	17.50
37619	Valve Cover Gasket (2 pc set)	1949-56 8 cylinder	24.50
6428	Valve Cover Gasket (2 pc set)	1957-58 8 cylinder	24.50
12421	Valve Cover Gasket (2 pc set)	1959-60 8 cylinder	24.50
IEM358	Intake-Exhaust Manifold Gasket Set	1935-48 6 cylinder	26.50
IEM378	Intake-Exhaust Manifold Gasket Set	1937-48 8 cylinder	32.50
IEM490	Intake-Exhaust Manifold Gasket Set	1949-50 6 cylinder	29.50
19014	Intake-Exhaust Manifold Gasket Set	1949-53 8 cylinder	33.50
19018	Intake-Exhaust Manifold Gasket Set	1954-56 8 cylinder	33.50
9414/9416	Intake Exhaust Manifold Gasket Set	1957-58 8 cylinder	33.50
9549/9550	Intake-Exhaust Manifold Gasket Set	1959-60 8 cylinder	33.50
6402	Timing Case Cover Gasket Set and Seal	1949-60 8 cylinder	23.50
6406	Water Pump Gasket	1949-60 8 cylinder	6.50
5142	Rear Main Bearing Seal (Rope type)	1937-50 6 cylinder	19.50
5145	Rear Main Bearing Seal (Rope type)	1949-60 8 cylinder	19.50
3772	Rear Main Bearing Seal (New Rubber Style)	1949-56 8 cylinder	39.50
3A46	Rear Main Bearing Seal (New Rubber style)	1957-58 8 cylinder	39.50
3A45	Rear Main Bearing Seal (New Rubber style)	1959-60 8 cylinder	39.50

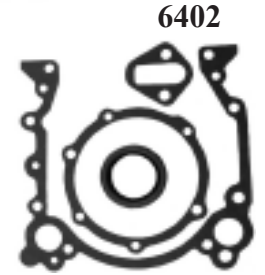
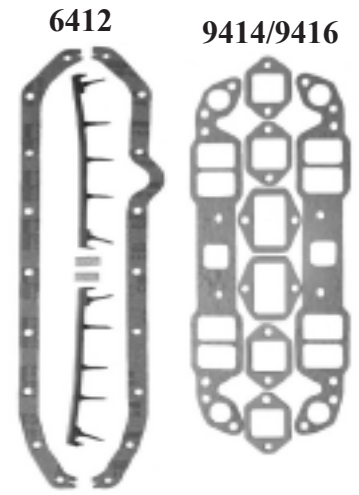

ENGINE PARTS

1949-60 FREEZE PLUG KITS:

These kits contain enough freeze plugs to complete your overhaul.

FPK1	Freeze Plug Kit (29 pcs)	1949-58 8 cylinder	48.00 kit
FPK2	Freeze Plug Kit (28 pcs)	1959-60 all	48.00 kit

1949-60 VALVE LIFTERS:

VL601	Valve Lifter	1949-51 8 cylinder	14.00 ea.
VL526	Valve Lifter	1952-56 all	14.00 ea.
VL574	Valve Lifter	1957-60 all	14.00 ea.

1949-60 PUSH RODS:

PR491	Push Rod	1949-51 8 cylinder	5.50 ea.
PR525	Push Rod	1952-55 all, 1959-60 all	5.50 ea.
PR560	Push Rod	1956 all	5.50 ea.
PR578	Push Rod	1957-58 all	5.50 ea.

1952-60 ROCKER ARMS AND ROCKER ARM SHAFTS:

RA528	Rocker Arm	1952-58 all	13.50 ea.
RA591R	Right Side Rocker Arm	1959-60 all	13.50 ea.
RA591L	Left Side Rocker Arm	1959-60 all	13.50 ea.
42010	Rocker Arm Shaft	1949-56 8 cylinder	49.00 ea.
42012	Rocker Arm Shaft	1957-59 all, 1960 first 12,000 cars	49.00 ea.
42013	Rocker Arm Shaft	1960 12001 VIN and up	49.00 ea.

1949-60 VALVE SPRINGS:

VS491	Valve Spring	1949-51 8 cylinder	6.50 ea.
VS525	Valve Spring	1952-55 all	6.50 ea.
VS560	Valve Spring	1956-60 all	6.50 ea.



**1949-60 INTAKE AND EXHAUST VALVES:**

EV493	Exhaust Valve	1949-53 8 cylinder	15.50 ea.
EV540	Exhaust Valve	1954 all	15.50 ea.
EV550	Exhaust Valve	1955 all	15.50 ea.
EV560	Exhaust Valve	1956-60 all	15.50 ea.
IV494	Intake Valve	1949-54 8 cylinder	15.50 ea.
IV558	Intake Valve	1955-58 all	15.50 ea.
IV590	Intake Valve	1959-60 all	15.50 ea.

1949-60 INTAKE AND EXHAUST VALVE GUIDE SETS: Sold in sets of 8 intake and 8 exhaust.

VG493	Valve Guide Set	1949-50 V8, 1951-53 all	80.00 set
VG541	Valve Guide Set	1954-60 all	80.00 set

**1949-60 TIMING CHAIN AND GEAR SETS:** Chain and gears should be replaced as a matched set

373/43/44	Timing Chain & Gear Set	1949-56 303-324 (64 links double flange 13/16"wide)	139.00 set
494/45/46	Timing Chain & Gear Set	1957-58 371 (48 links single flange 11/16" wide)	139.00 set
494/44/01	Timing Chain & Gear Set	1959-60 371-394 (48 links single flange 11/16" wide)	139.00 set

1949-60 PISTONS AND RINGS SETS: Pistons and rings are available in standard, oversize .010, .020, .030. We do not stock all size pistons and rings. Allow 1-2 weeks for shipment.

Specify size when ordering. Wrist pin bushings are included with piston sets.



P491	Piston and Pin Set	1949-51 303 V8	465.00 set
P523	Piston and Pin Set	1952-53 303 V8	465.00 set
P546	Piston and Pin Set	1954-56 324 V8	465.00 set
P578	Piston and Pin Set	1957-58 371 V8	465.00 set
P591	Piston and Pin Set	1959-60 371 V8	465.00 set
P594	Piston and Pin Set	1959-60 394 V8	465.00 set
PRS493	Piston Ring Set	1949-53 303 V8	75.00 set
PRS546	Piston Ring Set	1954-56 324 V8	75.00 set
PRS570	Piston Ring Set	1957-60 371 V8	75.00 set
PRS594	Piston Ring Set	1959-60 394 V8	75.00 set

**1949-60 CONNECTING ROD BUSHING TO PISTON PIN:** This bushing is installed on the piston end of the connecting rod.

CRB496	Connecting Rod Bushing	1949-60 All V8	6.00 ea.
---------------	------------------------	----------------	----------

**1950-60 ROD BEARING SETS:** Available in standard, undersize .010, or undersize .020. Specify size.

RB560	Rod Bearing Set	1950-56 8 cylinder	72.00 set
RB578	Rod Bearing Set	1957-58 all	72.00 set
RB590	Rod Bearing Set	1959-60 all	72.00 set

**1949-60 MAIN BEARING SETS:** Available in standard, undersize .010, or undersize .020. Specify size.

MB4	Main Bearing Set	1949-56 8 cylinder	115.00 set
MB5	Main Bearing Set	1957 all	115.00 set
MB6	Main Bearing Set	1958 all	115.00 set
MB7	Main Bearing Set	1959-60 all	115.00 set

**1949-60 CAM BEARING SETS:**

CB495	Cam Bearing Set	1949-55 8 cylinder	48.00 set
CB564	Cam Bearing Set	1956-60 all	48.00 set

1949-60 CAMSHAFTS: We have a limited supply of new camshafts for 1956 324, 1957-58 371, 1959-60 371 and 394 Engines. Original factory camshafts seemed to wear prematurely necessitating frequent replacement. 1949-55 8 cylinder SOC5 camshafts are now new camshafts not requiring a core charge.

SOC5	Camshaft	1949-55 V8	285.00
SOC1	Camshaft	1956-58 all	285.00
SOC2	Camshaft	1959-60 all	285.00

CARBURETOR REBUILD KITS:

We have all the kits to rebuild carburetors used by Oldsmobile, including the hard to find 1949-50 Rochester 2 barrels. These rebuild kits are made using new materials to better withstand today's more aggressive unleaded fuels. Kits include all the parts needed to rebuild your carb including new accelerator pumps. Floats and base gaskets are not included in kits (available separately, listed below). Please supply us with the carb number found on the small triangular tag on the carb. This will ensure you receive the correct kit for your application.

Please note that kits are non-returnable if opened.

1101	Carburetor Kit	1936-48 and 1942 all 6 cylinder Carter W1 1 barrel	47.50
1103	Carburetor Kit	1939-50 all 6 cylinder Carter WA-1 1 barrel	49.50
1104	Carburetor Kit	1936-37 all 8 cylinder Carter WDO 2 barrel	49.50
1104A	Carburetor Kit	1938-40 all 8 cylinder Carter WDO 2 barrel	49.50
1105	Carburetor Kit	1941-42, 1946, 1948 all 8 cylinder WDO Carter 2 barrel	49.50
1107	Carburetor Kit	1947 all 8 cylinder WCD Carter 2 barrel	49.50
1109	Carburetor Kit	1949-54 all 8 cylinder WGD Carter 2 barrel	49.50
1116	Carburetor Kit	1949-50 all 8 cylinder Rochester 2 barrel	68.00
1111	Carburetor Kit	1952-54 all 8 cylinder WCFB Carter 4 barrel	53.00
1118	Carburetor Kit	1951-53 8 cylinder Rochester 2 barrel	49.50
1120	Carburetor Kit	1952-53 8 cylinder Rochester 4 barrel	53.00
1122	Carburetor Kit	1954-56 all 8 cylinder Rochester 4 barrel	53.00
1124	Carburetor Kit	1954-55 all Rochester 2 barrel	49.50
1126	Carburetor Kit	1956 all Rochester 2 barrel	49.50
1128	Carburetor Kit	1957 all Rochester 4 barrel	57.50
1130	Carburetor Kit	1957-58 all 2 barrel, including J/2 option	47.50 ea.
1132	Carburetor Kit	1958-60 all Rochester 4 barrel	57.50



CARBURETOR BASE GASKETS: Base gaskets are the correct thickness and are made out of new material that will withstand today's unleaded fuels. Base gaskets are not included in carburetor rebuild kits above. Some applications require 2 gaskets.

564284	Carburetor Base Gasket	1949-55 2 barrel (requires 2)	8.50 ea.
561409	Carburetor Base Gasket	1952-53 4 barrel (requires 2)	12.50 ea.
568039	Carburetor Base Gasket	1956 2 barrel	11.00
562892	Carburetor Base Gasket	1954-56 4 barrel	13.50
570815	Carburetor Base Gasket	1957 4 barrel	13.50
571151	Carburetor Base Gasket	1957-58 2 barrel and J/2 applications	8.50 ea.
573280	Carburetor Base Gasket	1958-60 4 barrel	13.50

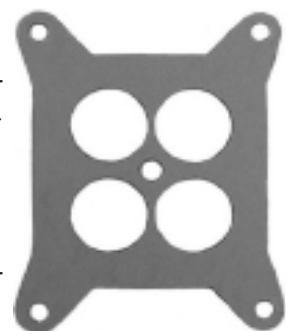

FLEXIBLE FUEL LINE HOSE: Flexible hose from the hard fuel lines on the frame up to the fuel pump.

11070	Fuel Line Hose	1939-40 8 cylinder, 1941-48 6 cyl	16.50
11202	Fuel Line Hose	1950-53 8 cylinder	16.50
11214	Fuel Line Hose	1954-55 all	16.50
11215	Fuel Line Hose	1956 all	16.50
11216	Fuel Line Hose	1957-58 all	16.50



New Delco-Remy Distributor, Starter & Generator Tags:

Replace your worn out and unsightly tags with these new reproductions. You will need to stamp the correct numbers needed in the center section. Distributor tags have correct curvature to them to mount flush on housing. Generator and Starter tags are available for 6 Volt (printed in black) or 12 Volt (printed in red). Correct rivets for installation are included with each tag.

GTB35	Black 6 Volt Generator & Starter Tag	1935-52	7.50
GTR53	Red 12 Volt Generator & Starter Tag	1953-60	7.50
DT35	Black Distributor Tag	1935-55	7.50



FUEL TANK SENDING UNITS

1939-60 NEW FUEL TANK UNITS: Tank units include new gasket, mounting screws, and washers.

For 1949 Oldsmobiles please check if your unit has a fuel pick-up line, or a separate line on side of fuel tank.

FTU390	Fuel Tank Sending Unit	1939 all except station wagons	84.50
FTU418	Fuel Tank Sending Unit	1941-49 all except station wagons	84.50
FTU50	Fuel Tank Sending Unit	1950 all models except station wagons	94.50
FTU513	Fuel Tank Sending Unit	1951-53 all models	94.50
FTU545	Fuel Tank Sending Unit	1954-55 all models	94.50
FTU560	Fuel Tank Sending Unit	1956 all models	94.50
FTU578	Fuel Tank Sending Unit	1957 all, 1958 without air conditioning	94.50
FTU590	Fuel Tank Sending Unit	1959-60 all without air conditioning	94.50



OIL AND TEMPERATURE SENDING UNITS:

PS12	Oil Sending Unit	1956-60 all	14.50
PSB12	Oil Sending Unit Rubber Boot	1956-60 all	4.75
TS6	Temperature Sending Unit (12 volt)	1953-55 all	17.50
TS15	Temperature Sending Unit	1956-58 all	18.50



ENGINE AND TRANSMISSION MOUNTS: New engine and transmission mounts for the applications listed below. ***Core charge of 50.00 per pair is assessed on transmission mounts 752264 and 753407** until your old mounts are returned to us. These are difficult mounts to obtain and must be sent to the manufacturer for revulcanizing.

758073	Front Lower Motor Mount	1937-53 all	39.00
572945	Front Lower Motor Mount	1954-60 all	39.00
752264	*Transmission Mounts	1936-38 6 cylinder	89.00 pr.
753407	*Transmission Mounts	1939-48 6 cylinder, 1940-48 Hydramatic exc 1948 98	89.00 pr.
758081/2	Transmission Mounts	1948 98, 1949-53 all, 1954-56 standard trans.	65.00 pr.
759263/4	Transmission Mounts	1954-56 all Hydramatic	65.00 pr.
568980/1	Transmission Mounts	1957-60 all except standard transmission	65.00 pr.



1939-59 ENGINE OIL FILTERS: Because of infrequent usage of collector cars we recommend a filter replacement at each oil change.

P112	Engine Oil Filter	1939-47 all	15.00
P115	Engine Oil Filter	1948 all, 1949-50 6 cylinder	15.00
PF122	Engine Oil Filter	1949-59 8 cylinder	13.50



HYDRAMATIC TRANSMISSION PAN GASKETS AND TRANSMISSION SEALS

13021E	Transmission Pan Gasket (12 pan bolts)	1946-55 all, 1956 type "R" Hydramatic	12.50
15030E	Transmission Pan Gasket (15 pan bolts)	1956 type "O", 1957-59 Hydramatic	12.50
13074E	Transmission Pan Gasket	1960 Hydramatic	12.50
49721	Transmission Front Pump Seal	1946-55 all, 1956 type "R" Hydramatic	29.50
23659	Transmission Front Pump Seal	1956 type "O", 1957 Hydramatic	33.00
24889	Transmission Front Pump Seal	1958-60 Hydramatic	29.50
1314707	Transmission Rear Tail Shaft Seal	1939-50 Hydramatic, 1939-56 standard trans.	23.50
46144	Transmission Rear Tail Shaft Seal	1952-54, 1956 type "O", 1957-60 Hydramatic	23.50
8617123	Transmission Rear Tail Shaft Seal	1955, 1956 type "R" Hydramatic	23.50



TRANSMISSION LINE COOLANT HOSES: Uses 2 per car, fits 1956 Jetaway and all 1957-60 Hydramatic transmissions.

4300	Transmission Coolant Hoses	1956, type "O", 1957-59 Hydramatic	16.50 ea.
-------------	----------------------------	------------------------------------	-----------

1948-56 TORUS COUPLING COVER GASKET: 30 hole gasket that seals flywheel and transmission fluid coupling on all Hydramatic transmissions, 1948-56 except 1956 Jetaway.

TCG14047E	Torus Coupling Cover Gasket	1948-56 Hydramatic exc. 1956 Jetaway	14.50
------------------	-----------------------------	--------------------------------------	-------



1955-58 ALL POWER STEERING PRESSURE AND RETURN HOSE KIT:

Exact pressure hose as original with correct bent steel ends and correct length return hose with original style clamps.

PSH55	Power Steering Hose Kit	1955 all	59.50 kit
PSH56	Power Steering Hose Kit	1956 all	59.50 kit
PSH578	Power Steering Hose Kit	1957-58 all	59.50 kit
PSH590	Power Steering Hose Kit	1959-60 all	59.50 kit
H5	Power Steering Return Hose Clamp	1955-60 all	3.50 ea.



1956-60 POWER STEERING COUPLING:

PSC560	Power Steering Gear Box to Steering Shaft Flexible Coupling (Rag Joint) Fits all 1956-60 Models with power steering		14.50
---------------	---	--	-------

1949-60 INTAKE MANIFOLD CHOKE TUBE: Usually destroyed over time from heat and carbon. Deteriorated tube can contribute to hard starting when car is cold. Fits all 1949-60 8 cylinders.

555959	Manifold Choke Tube	1949-55 8 Cylinder	26.50
567675	Manifold Choke Tube	1956-60 all	26.50

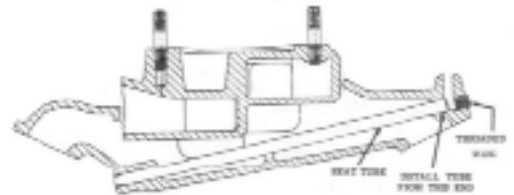

1949-60 EXHAUST MANIFOLD HEAT RISER VALVE: Often frozen in open or shut position, this valve should be replaced to ensure proper engine operation. Exhaust flange gaskets also available. Requires 4 gaskets per car.

HRV490	Heat Riser Valve	1949-60 8 Cylinder	79.50
563689	Exhaust Flange Gasket	1949-60 8 Cylinder	4.50 ea.



1949-56 EXHAUST MANIFOLD STUDS: Often rusted or broken.

9686/90	Exhaust Manifold to Cylinder Studs (12 pcs)	1949-53 V8	22.00 set
9686	Exhaust Manifold to Crossover Pipe Flange Studs (6 pcs)	1949-53 V8	12.00 set
9686A	Left Exhaust Manifold to Crossover Pipe Flange Studs (3 pcs)	1954-56 all	6.00 set



1955-60 POWER WINDOW MOTORS:

New Power Window Motors for all 1955-1960 2 and 4 Door Oldsmobiles with power windows. These motors have a square body, original motors from 1955-58 had a round body, and 1959 could have had either one. These will fit all Oldsmobiles from 1955-60.

M3898	Right Power Window Motor (passenger side)	1955-60 all	139.00 ea.
M3899	Left Power Window Motor (driver side)	1955-60 all	139.00 ea.

HYDRAULIC SYSTEM WINDOW AND SEAT CYLINDERS: Newly manufactured cylinders using modern materials. Available for all 1946-60 Oldsmobiles. Please be specific on year and model.

W612	Front or Rear Door Window Cylinder	1946-54 all	149.00 ea.
Q712	Rear Quarter Window Cylinder (2 doors)	1946-54 all	149.00 ea.
S812	Hydraulic Seat Cylinder	1949-54 all	149.00 ea.



CONVERTIBLE TOP CYLINDERS: New cylinders manufactured for 1946-60 Oldsmobiles. Applications vary so please be specific with model and year.

CT98	Convertible Top Cylinder	1946-60 convertibles	149.00 ea.
-------------	--------------------------	----------------------	------------

CONVERTIBLE TOP MOTOR PUMP AND HOSES: TP1 Pump is a universal replacement for all 12 volt hydraulic systems from 1955-56. TP2 is a direct replacement for 1957-60. Hoses are black rubber with 90 degree brass fittings. Call for price and availability on 6 volt models.

TP1	Convertible Top Motor/Pump	1955-56 all convertibles	249.00
TP2	Convertible Top Motor/Pump	1957-60 all convertibles	249.00
CTH561	Convertible Top Hoses	1955-60 all convertibles	109.00 pr.



SUSPENSION PARTS

TUBULAR SHOCK ABSORBERS

Tubular shock absorbers custom made for the 1951-60 Oldsmobiles. Designed as exact mechanical replacements for original shock absorbers long discontinued by OEM manufacturers.

50094G	Rear Gas Charged Shock Absorber	1951-56 all except 1951 88A	39.50 ea.
50141G	Rear Gas Charged Shock Absorber	1957-60 all except air ride	39.50 ea.
50103G	Front Gas Charged Shock Absorber	1955 all	39.50 ea.
50128G	Front Gas Charged Shock Absorber	1956 all	39.50 ea.
50140G	Front Gas Charged Shock Absorber	1957-60 all except air ride	39.50 ea.



SHOCK MOUNTING STUDS AND GROMMETS

New Shock Mounting Studs are now available for 1951-56 Oldsmobiles. Studs are sold each and Rubber grommets are sold in a set of 8.

RSM516	Rear Shock Mount Stud	1951 all except 88A, 52-56 all	16.50 ea.
RSMG516	Rear Shock Mount Grommet Set (8 per car)	1951 all except 88A, 52-56 all	22.00 set of 8



STABILIZER BAR BUSHINGS: The stabilizer bar bushings and link kits are essential in cornering maneuvers and help to eliminate a diving or swaying sensation on turns. Bushings are the proper shape before installation and assume the correct crushed shape when installed on the stabilizer bar and mounted on the car.

411392	Front Stabilizer Bar Bushing	1939-57 all	16.50 pr.
411392	Rear Stabilizer Bar Bushing	1941-56 all	16.50 pr.
573287	Front Stabilizer Bar Bushing	1958-60 all	19.50 pr.



STABILIZER LINK KITS:

18001	Front Stabilizer Link Kits	1939-56 all	23.50 pr.
18035	Front Stabilizer Link Kits	1957-59 all	23.50 pr.
18001A	Rear Stabilizer Link Kits	1948-56 all	23.50 pr.

KNEE ACTION SHOCK ABSORBERS:

We can rebuild your existing 1937-54 Front Shock Absorbers and 1937-50, 1951 88A Rear Shock Absorbers. Core Charge for shocks is 95.00 ea. Shocks that are frozen or have side to side play are not rebuildable. You will be assessed the 95.00 core charge per non-rebuildable shock. Please add normal Fed Ex shipping charges found on inner front cover of catalog.

FKS354	Front Knee Action Shocks	1935-54 all	295.00 pr.
RKS351	Rear Knee Action Shocks	1935-50 all, 1951 88A	245.00 pr.

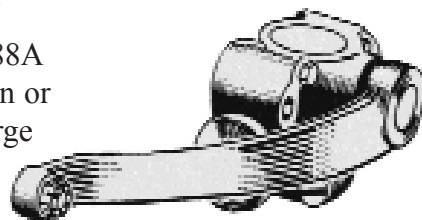

REAR SHOCK LINK PACKAGE:

Used on 1937-50 and 1951 88A Rear Lever Action Shock Absorbers. Includes rubber bushings and attaching hardware. Priced per pair.

5315895	Rear Shock Links	1937-38 all	59.50 pr.
5313880	Rear Shock Links	1939 all, 1940 60-90 Series	59.50 pr.
5352365	Rear Shock Links	1941-50 all, 1951 88A	59.50 pr.

WHEEL BEARINGS: Each bearing includes cup, cone, and spacer.

909001	Front Wheel Bearing outer	1939-56 all	59.50 ea.
909025	Front Wheel Bearing outer	1937-38, 1957-58 all	59.50 ea.
909052	Front Wheel Bearing inner	1940-52 all	59.50 ea.
909062	Front Wheel Bearing inner	1953-58 all	59.50 ea.
909066	Front Wheel Bearing inner	1959-60 all	59.50 ea.
909073	Front Wheel Bearing outer	1959-60 all	59.50 ea.
88128R	Axle Bearing Assembly rear	1939-60 all	49.50 ea.



909001

909062

FRONT WHEEL, PINION SHAFT, AXLE SEALS: Replace your worn out Oil Seals when installing new Wheel Bearings. The Pinion seal is located where the driveshaft goes into the rear end.

410950	Front Wheel Grease Seal	1939-52 all	19.50 ea.
20154	Front Wheel Grease Seal	1953-58 all	19.50 ea.
579207	Front Wheel Grease Seal	1959-60 all	23.50 ea.
232000	Axle Oil Seal	1937-38 all	19.50 ea.
15380	Axle Oil Seal	1939-54 all	21.50 ea.
54062	Axle Oil Seal	1955-60 all	19.50 ea.
501839	Pinion Shaft Oil Seal at Differential	1937-47 all	19.50
514066	Pinion Shaft Oil Seal at Differential	1948-52 all	19.50
19438	Pinion Shaft Oil Seal at Differential	1953-60 all	19.50



15380

20154



19438



ES140R

1939-60 OUTER TIE ROD ENDS: New Outer Tie Rods and Sleeves available to replace worn originals. Inners are not available new at this time, but we occasionally get them in. Check the NOS listing in the back of the catalog.

ES140R	Tie Rod End	1939-60 all	39.50 ea.
ES500S	Tie Rod End Sleeve	1939-60 all	19.50 ea.
6160	Tie Rod End Rubber Boot (Included with ES140R)	1937-60 all	4.00 ea.



K50

K90

KING BOLT, UPPER AND LOWER PIVOT PINS AND SEALS:

K90	King Bolt Set. Complete kit to service both front wheels. For all 1937-56 Oldsmobiles.		57.00 set
K60	Upper Control Arm Pivot Pin Kit for 1936-54 all Models at shock Each K60 does one side of your car.		49.50 per side
K65	Upper Control Arm Pivot Pin Kit for 1955-56 all Models. Each K65 does one side of your car.		49.50 per side
K50	Lower Control Arm Pivot Pin Kit for 1939-56 all Models at lower steering knuckle. Each K50 does one side of your car		49.50 per side
K80	Lower Control Arm Inner Shaft Package	1939-60 all 2 per car	65.00 per side
K85	Upper Control Arm Inner Shaft Package	1955-60 all 2 per car	69.00 per side
6166	Lower Control Arm Pivot Pin Seals	1936-56 all 4 per car	2.00 ea.
6167	Lower Control Arm Inner Shaft Kit Seals	1939-60 all 4 per car	2.00 ea.
6178	Upper Control Arm Pivot Pin Seals	1936-60 all 4 per car	2.00 ea.



K85

K65

K80

IDLER ARM ASSEMBLIES: New Idler Arm Assemblies available for 1941-56 All models. Support Bracket kit includes new bushings, bracket, rubber seals and grease fitting.

K75	Idler Arm Support Bracket Kit	1939-60 all	69.50
18521	Idler Arm Assembly	1941-48 all	79.00
18522	Idler Arm Assembly	1949-56 all	79.00



18522

K75

1298323 Upper Control Arm Rubber Bumper: Attaches to frame under shock absorber Arm. Fits all 1937-56 Models

13.50 ea.



411143 Lower Control Arm Rubber Bumper: Attaches to lower control arm on 1939-56 models. 18.50 ea.

571020 Upper Control Arm Rubber Bumper: Attaches to upper control arm. For all 1957-60 Models.

14.50 ea.



568866 Lower Control Arm Rubber Bumper: Attaches to lower control arm on all 1957-58 models. 18.50 ea.



AHB540 Axle Housing Bumper: Fits all 1954-60 models. Uses 2 per car. 14.50 ea.



BODY MOUNTS AND PADS:



BM378 Body Mount Pads: Fits all 1937-50, 1951 88A Models. Uses approximately 16 pads per car. Check your Olds for accurate count. Fabric reinforced rubber as original.

BM378 Body Mount Pad 7.50 ea.

BM518 Body Mounts: Fits all 1951-58 except 1951 88A. Upper and lower with steel collar in lower section. Uses approximately 16 mounts per car. Check your Olds for accurate count. Includes hardware.

BM518 Body Mounts 12.50 ea.

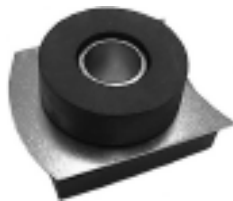

FRONT FENDER WELL

A-FRAME SEALS: Accurate reproductions of the original die cut masticated rubber A-Frame Seals used on 1954-55, 57-60 Oldsmobiles. Fasteners are included.

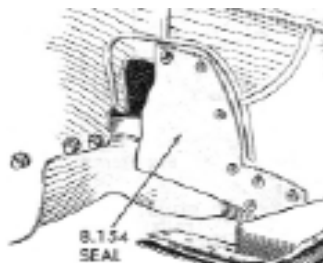

FCD10 Fender Well Seals 1954-55 all 24.50 pr.

FCD11 Fender Well Seals 1957-58 all 24.50 pr.

FCD12 Fender Well Seals 1959-60 all 24.50 pr.

405999 1939-56 Front Wheel Dust

Cap: New reproduction cap for all 1939-56 models. Replaces damaged or missing caps. Quality stamped steel.

14.50 ea.



Axle to Rear End Housing Gaskets (A) and Brake Backing Plate to Axle Gaskets (B) (4 piece set) Die cut gaskets apply to 1939-60 All Models.

ABP390 Axle & Brake Plate Gaskets 14.50 set

ABP390

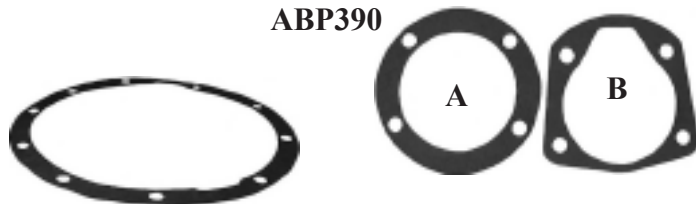

DIFFERENTIAL HOUSING GASKETS:

230972 Housing Gasket 1927-36 All 13.50

555262 Housing Gasket 1937-52 All 13.50

562426 Housing Gasket 1953-56 All 13.50

569569 Housing Gasket 1957-60 All 13.50

NEW DRIVESHAFT UNIVERSAL JOINTS:

114-2101 U Joint 1939-53 all Front 43.50

114-2100 U Joint 1939-52 all Rear 43.50

114-3011 U Joint 1954-56 all Front Hydra. 37.50

114-3102 U Joint 1954-56 all Rear Hydra. 43.50

114-3011 U Joint 1957-60 all Front-Center-Rear (Saginaw- Inner Snap Rings) 37.50 ea.

570816/7 U Joint 1957-60 all Front-Center-Rear * (Spicer-Outer Snap Rings) 38.50 ea.

* note: On 57-60 spicer U-Joints please specify location needed (front, center or rear)



DRIVESHAFT CENTER SUPPORT MOUNTS AND BEARINGS:

Used on all 1957-60 models.

88508 Driveshaft Center Bearing 1957 all, 1958 1st Type (1 1/32" thick) 56.50

6908 Driveshaft Center Bearing 1958 2nd type, 1959-60 all (19/32" thick) 66.50

570049 Driveshaft Support Mount 1957 all except Convertibles, all 1958 models 50.00

570050 Driveshaft Support Mount 1957 Convertibles 65.00

573356 Driveshaft Support Mount all 1959-60 models 63.50

WHEEL LUG NUTS: Fits all 1937-60 Models. Oldsmobile used left hand thread for drivers side of car, and right hand thread for passenger side of car. Lug nuts and studs are sold individually. Left thread wheel studs have been increasingly difficult to find. We have taken them out of the catalog, you can use the right thread studs for the left side of car (driver side)

8743	Lug Nut (left thread to tighten, drivers side)	1937-60 All	1.95 ea.
8744	Lug Nut (right thread to tighten, passenger side)	1937-60 All	1.95 ea.
499908	Front Wheel Stud (right thread to tighten, passenger side)	1937-60 All	8.50 ea.
499542	Rear Wheel Stud (right thread to tighten, passenger side)	1937-60 All	8.50 ea.



REAR LEAF SPRINGS AND ATTACHING HARDWARE: Fit 1951 to 1960 All models except 1951 88A. Rear Leaf Springs are made to exact specifications for your car. Please provide a complete description when ordering and allow 2-3 weeks delivery time.

RL510	Rear Leaf Springs	1951-60 All except 1951 88A	365.00 pr.
RSS510	Rear Spring Shackle Kit	1951-60 All except 1951 88A 2 kits needed per car.	42.00 kit
	Each kit includes 4 rear spring shackle rubber bushings, shackle, link, and lock nuts.		
RSB510	Rear Spring Shackle Bushings	1951-60 All except 1951 88A	48.00 set of 12
RSE510	Rear Spring Front Eyelet Bolt & Bushings	1951-60 All except 1951 88A	12.50 ea.
RSB511	Rear Spring Insulator Pad	1951-60 All except 1951 88A Requires 4 per car.	13.50 ea.
RSUB516	Rear Spring U-Bolts	1951 S88 & 98, 1952-56 All Models	16.50 ea.
RSUB578	Rear Spring U-Bolts	1957-58 All except Convertibles	16.50 ea.



RSS510

Rear Axle Housing Rubber Insulators: Upper and lower sections for all 1941-50 models and 1951 88A. Uses 8 pieces per car.

AHI410 Rear Axle Insulators 65.00 8 pc set



RSB511

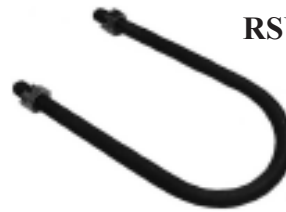

RSUB578



RAS510

Rear Axle Support Arm Bushings: Used on all 1941-50 and 1951 88A. Set of 4 services one car.

RAS510 Axle Arm Bushings 32.00 set of 4

Differential Housing Bumper: Used on all 1957-60 Models. 1 used per car.

DHB570 Differential Housing Bumper 18.50



COIL SPRINGS:

We can supply new coil springs for all 1941-60 Oldsmobiles. Front Coil Springs were used on all 1941-60 models, while rear coils were installed 1941-50 all and 1951 88A models. Leaf Springs were used on 1951 Super 88-98 and 1952-60 models. Since there are a large amount of coil spring applications we do not stock the springs.

All coil spring requests will be filled on a special order basis. Please provide a complete description of your car when ordering (year, model, engine size, air cond., sedan or hardtop, convertible, etc.) and allow 2-3 weeks for delivery.

CS30F	Front Coil Springs	165.00 pair
CS40F	Rear Coil Springs	165.00 pair
562197	Front Coil Spring Insulators (Spring to Frame): 1941-60 All Models.	13.50 ea.



BN6



BN7

1941-51 Rear Axle Housing Track Bar Bushings: Worn Track Bar Bushings are the reason for the thumping noise you may have experienced on your 1941-50 All, 1951 88A. Each set services one car.

BN6	Bushings	1941-48 All	36.00 set
BN7	Bushings	1949-50 All, 1951 88A	21.50 set

WIRING HARNESSSES

We are offering authentic Wiring Harnesses for 1949-58 Oldsmobiles. 1949-54 Models use cloth covered wiring while 1955-58 Oldsmobiles use the plastic-coated wire. Correct Wiring Harnesses require several man hours to manufacture. Their cost is relative to labor involvement.

1998763 Wire Junction Terminal Board:

Fits 1942-50 All, 1951 88A
19.50 ea.



1865535 Wire Junction Terminal Board:

Fits 1935-41 All, 1951 Super 88 and 1952 All with minor alteration.
16.50 ea.

Harnesses for 1949-50 88 & 98 Models:

H49A	Cowl, Engine, & Headlight Harness (main harness with turn signals)	585.00
H49C	Cowl, Engine, & Headlight Harness 1949 98 Models only.	595.00
H50C	Cowl, Engine, & Headlight Harness 1950 98 Models only.	595.00
HB49A	Body Harness (4 door models)	285.00
HB49B	Body Harness (convertible)	285.00
HB49C	Body Harness (2 door models)	285.00
HS49	Turn Signal Harness	79.00
HH49	Headlight Bucket Wires	79.00 pr.
HP49	Park/Turn Signal Wires (in column)	59.00 pr.
HHD49	Heater & Defroster Wires	59.00
HC49	Clock Harness	49.00

Harnesses for 1951 Super 88 Models:

H51S	Cowl, Engine, & Headlight Harness (main harness with turn signals)	595.00
H51B	Body Harness (88 2 door models)	295.00
HH51S	Headlight Bucket Wires	75.00 pr.
HP51S	Park/Turn Signal Wires	69.00 pr.

Harnesses for 1952 All with Hydramatic:

H52	Cowl, Engine, & Headlight Harness (main harness with turn signals)	585.00
HH51S	Headlight Bucket Wires	79.00 pr.
HP51S	Park/Turn Signal Wires	69.00 pr.



Typical Main Harness

Harnesses for 1953 All with Hydramatic:

H53	Cowl, Engine, and Headlight Harness (main wiring harness)	585.00
H53C	Cowl, Engine, & Headlight Harness 98 Fiesta Models Only.	595.00
HB53C	Body Harness 98 Convertible only	625.00
HH53	Headlight Bucket Wires	76.00 pr.
HP53	Park/Turn Signal Wires	66.00 pr.
HTM53	Convertible Top Motor Harness	39.00
HC53	Clock Harness	39.00
HBU53	Back-up Light Harness	33.50

Harnesses for 1954 All with Hydramatic:

H54	Cowl, Engine, and Headlight Harness (main harness)	595.00
HH54	Headlight Bucket Wires	69.00 pr.
HP54	Park/Turn Signal Wires	49.00 pr.

Harnesses for 1955 All with Hydramatic:

H55	Main Harness (no Air)	565.00
H55AC	Main Harness (w/ Air)	585.00
HH54	Headlight Bucket Wires	59.00 pr.

Harnesses for 1956 All with Hydramatic:

H56	Main Wiring Harness	565.00
HH54	Headlight Bucket Wires	59.00 pr.

Harnesses for 1957 All with Hydramatic:

H57	Main Wiring Harness (88 only)	565.00
H57A	Main Wiring Harness (S88 & 98)	575.00
HH57	Headlight Bucket Wires	59.00 pr.

Harnesses for 1958 All with Power Brake and Hydramatic Transmission: Main Harness does not include Fuse Block.

H58	Main Harness (88 only)	565.00
H58A	Main Harness (S88 & 98)	575.00
HH58	Headlight Bucket Wires	53.00 pr.

Note on 1958 Wiring Harnesses, you will need to send in your old harness and fuse box first. The manufacturer needs to re-use fuse box and wire connections.

Typical Headlight Harness



COOLING SYSTEM

MOLDED UPPER AND LOWER RADIATOR HOSES: We have all the upper and lower molded radiator hoses for Oldsmobile from 1949-1960. Hoses have the correct molded bends and original GM part number stamped on them.

556036	Radiator Hose (lower)	1949-50 88, 1951 88A, 1952 All	27.50
564361	Radiator Hose (lower)	1953-56 All	27.50
572557	Radiator Hose (lower)	1957-58 All	27.50
574876	Radiator Hose (lower)	1959-60 All	27.50
405561	Radiator Hose (upper)	1935-52 All exc. 1948 98, and 1952 2nd type	22.50
416480	Radiator Hose (upper)	1948 98	26.50
562114	Radiator Hose (upper)	1952 2nd type (curved)	26.50
567660	Radiator Hose (upper)	1953 2nd type (exc. Dynaflow & A/C) 1954-56 All	26.50
569333	Radiator Hose (upper)	1957 All with 4 barrel carburetor	26.50
571149	Radiator Hose (upper)	1957 with J/2 and all 2 barrel carburetor	26.50
572556	Radiator Hose (upper)	1958 All with 4 barrel carburetor	26.50
572689	Radiator Hose (upper)	1958 with J/2 and all 2 barrel carburetor	26.50
574875	Radiator Hose (upper)	1959-60 All with 4 barrel carburetor	26.50
574789	Radiator Hose (upper)	1959-60 All with 2 barrel carburetor	26.50



MOLDED HEATER HOSES: Correct shape molded hoses with 5 rib design and original GM part number. The hoses listed below are made exclusively from our tooling.

28401	Heater Hose 5/8" (black universal)	1935-53 All	4.50 ft.
564894	Molded Heater Hose (temperature control valve to heater)	1954-56 All	26.50
565064	Straight Heater Hose (water pump to heater)(not molded)	1954-56 All	27.50
564237	Molded Heater Hose (temperature control valve to Cyl. head)	1954-56 All	27.50
* 571044	Molded Heater Hose (temperature control valve to Cyl. head)	1957-58 All	30.50
570146	Molded Heater Hose (water pump to heater)	1957-58 All	29.50
* 571106	Molded Heater Hose (temperature control valve to heater)	1957-58 All	30.50
** 573669	Molded Heater Hose (temperature control valve to heater)	1958 All	28.50
575769	Molded Heater Hose (temperature control valve to heater)	1959-60 All	26.50
581993	Molded Heater Hose (water pump to heater)	1959-60 All	31.50



*This hose used with 1958 first type heater control valve on firewall.

**This hose used with 1958 second type heater control valve in engine block.

ORIGINAL STYLE HOSE CLAMPS: After much research and tooling expenses, we now offer the correct clamps for all Oldsmobile applications from 1935 through 1960. Historical photographs show the Band type clamp was used prior to 1949 and the Double Wire Grip type and Spring Wire combination was in use from 1949 to 1960.

	H8	Band Type Heater Hose Clamp (5/8" hose)	1935-53 All	3.50 ea.
	H15	Band Type Upper Radiator Hose Clamp	1935-48 All	4.50 ea.
	H20	Band Type Lower Radiator Hose Clamp	1935-48 All	4.50 ea.
	HC58	Spring Wire Heater Hose Clamps (5/8" hose)	1954-56 All	1.25 ea.
	HC59	Spring Wire Heater Hose Clamps (3/4" hose)	1957-60 All	1.25 ea.
	HC128	Double Wire Hose Clamp.	1949-60 Upper Hose	4.50 ea.
	HC202	Double Wire Hose Clamp.	1949-60 Lower Hose at Radiator, 1949-56 Lower at Water Pump	4.50 ea.
	HC212	Double Wire Hose Clamp.	1957-60 Lower Hose at Pump	4.50

Band Type Clamps



Spring Ring Clamps

Double Wire Clamps



1941-58 HEATER CONTROL VALVES:

We are now offering the hard to find heater control valves. These valves are rebuilt, tested and restored. **Core charge on all heater control valves is 85.00.** We need 1954-56 cores. We are able to rebuild any non-Oldsmobile Heater Control Valve made by Ranco, regardless of make and model. Call for information on rebuilding service.



3120343	Heater Control Valve	1941-48 All except 1948 98	94.50
3121987	Heater Control Valve	1949 All	94.50
3127005	Heater Control Valve	1950 76-88 with Deluxe Heater	94.50
3127213	Heater Control Valve	1951-53 All except 1951 88A	94.50
569689	Heater Control Valve	1954-56 All	94.50
570811	Heater Control Valve	1957 All, 1958 1st type on firewall	94.50

1937-40, 1948-60 AC DELCO REPRODUCTION RADIATOR CAPS:

Beautiful reproductions of radiator caps used by Oldsmobile.

RC10R	Radiator Cap	1937-40 All	26.50
RC2R	Radiator Cap	1948 All, 1949-50 6 Cylinder	26.50
RC1R	Radiator Cap	1949-56 All 8 Cylinder	26.50
RC15	Radiator Cap	1957-60 All with Air Conditioning	26.50
RC6R	Radiator Cap	1957-60 All without Air Conditioning	26.50



THERMOSTATS, THERMOSTAT HOUSINGS & GASKETS:

300-160	Thermostat 160 degree	1937-60 All (1937-48 Models require a retainer)	11.50
TG378	Thermostat Gasket	1937-48 All, 1949-50 76	4.50
TG498	Thermostat Gasket	1949-60 8 Cylinder except 1957-58 All 2 Barrel and J/2	4.50
TG578	Thermostat Gasket	1957-58 All 2 Barrel and J/2 Option	4.50



THERMOSTAT HOUSINGS: Fit All 1956 to 1958 Models. Correct Reproduction Thermostat Housings to replace cracked or deteriorated originals. 567874 Housing can be used on 1949-55 V8 engines.

567874	Thermostat Housing	1956 All, 1957-58 4 Barrel	28.50
571145	Thermostat Housing	1957-58 All 2 Barrel and J/2 Option	29.50



FAN, GENERATOR, & POWER STEERING BELTS: By Gates Rubber Company.

562	Fan & Generator Belt	1937-47 all, 1948 6 cylinder, 78 Hydramatic	28.50
7370	Generator Belt	1949-50 8 Cylinder	24.50
7390	Fan & Water Pump Belt	1949-51 8 Cylinder	24.50
7417	Generator Belt	1951 8 Cylinder	24.50
7575	Fan & Generator Belt	1952-58 all without A/C	24.50
7580	Fan & Generator Belt	1959-60 all without A/C	24.50
7560	Fan & Power Steering Belt	1952 all	24.50
7565	Power Steering Belt	1953-56 all	24.50
7565	Power Steering Belt	1957-58 exc. 1958 w/Air Ride or A/C	24.50
7650	Power Steering Belt	1959-60 all except Air Conditioning	24.50



1937-60 FUSE PACKAGES: The fuses listed are sold in packages of 5 at 4.50 per package. Keep a selection in your glove box.

AGA-1	1 Amp Fuse	4.50	AGC-20	20 Amp Fuse	4.50	**SFE-2	2 Amp Fuse	4.50
AGA-3	3 Amp Fuse	4.50	AGC-25	25 Amp	4.50	SFE-4	4 Amp Fuse	4.50
AGA-5	5 Amp Fuse	4.50	AGC-30	30 Amp Fuse	4.50	SFE-9	9 Amp Fuse	4.50
AGC-2	2 Amp Fuse	4.50	AGW-4	4 Amp Fuse	4.50	SFE-14	14 Amp Fuse	4.50
AGC-15	15 Amp Fuse	4.50	*AGW-7 1/2	7 1/2 Amp Fuse	4.50	SFE-20	20 Amp Fuse	4.50

* Use SFE-7 1/2 7 1/2 Amp Fuse ** Use AGA-2 2 Amp-Fuse

LAMP BULBS

ORIGINAL EQUIPMENT 12 VOLT T3 BULBS:

Exact reproductions of the T3 Bulbs used in 1956-59 Oldsmobiles. 1956-57 Oldsmobiles used a dual beam system, while 1958-59 used a set of four bulbs.

T3567	T3 Sealbeams	1956-57 All Models	115.00 pr.
T3589	T3 Sealbeams (1 Hi, 1 Lo)	1958-59 All Models	59.50 pr.



1935-52 ALL MODELS 6 VOLT SYSTEM BULBS:

51	Dash Turn Signal, Radio, Shift Indicator	1935-52 All	3.50 ea.
55	Instruments, Clock, Glove Box	1935-52 All	3.50 ea.
63	Parking or Fender Lamp w/o Turn Signal	1935-52 All	4.50 ea.
81	License, Trunk, Underhood Lamps	1935-52 All	4.50 ea.
82	Dome Light Various models	1949-52 All	4.50 ea.
1133	Back-up Lamps	1941-52 All	5.75 ea.
1154	Tail or Brake Light with Turn Signal	1940-52 All	4.50 ea.
1154	Parking Light with Turn Signal	1940-52 All	4.50 ea.
6006	Headlight Sealbeam	1940-52 All	18.25 ea.
55,63,81,82	Dome Light (used various bulbs from 1940-52)	1940-52 All	see above

1953-60 ALL MODELS 12 VOLT SYSTEM BULBS:

53	Ash Tray and Headlight Dash Beam	1953-60 All	3.50 ea.
57	Dash Instruments, Radio, Clock, Glove Box, Hand Brake	1953-60 All	3.50 ea.
67	License Lamp	1953-60 All	3.50 ea.
89	Underhood and Trunk Lamps	1953-60 All	3.50 ea.
89,90	Courtesy Lamps	(check your existing bulb)	3.50 ea.
90,1004	Dome Light	(check your existing bulb)	3.50 ea.
1073	Directional Signal (rear), Back-up Lights	1953-60 All	4.50 ea.
1157	Parking Light or Directional Signal	1953-60 All	4.50 ea.
1157	Stop and Tail Lamp with Directional Signals	1953-60 All	4.50 ea.
6014	Headlight Sealbeam	1953-57 All	18.25 ea.
4000	Headlight Sealbeam (low beam)(Replacement, not T3)	1958-60 All	16.50 ea.
4001	Headlight Sealbeam (high beam)(Replacement, not T3)	1958-60 All	16.50 ea.

IGNITION, DOOR, TRUNK AND GLOVE BOX LOCKS AND KEYS

Locks are available individually or in sets. All Locks and Sets supplied with two original style keys.

IGNITION LOCK CYLINDER

IC3565 1935-60 All Ignition Lock Cylinder 23.50

DOOR LOCKS

DL54	1954 All Models	63.00 pr.
DL556	1955-56 All Models	63.00 pr.
DL590	1959-60 All 2 Door Models	63.00 pr.
DL590A	1959-60 All 4 Door Models	63.00 pr.

GLOVE BOX LOCKS

GB492	1949-52 All Models	35.00
GB656	1953-55 All Models	46.00
GB578	1957-58 All Models	46.00
GB624	1959-60 All Models	36.00

TRUNK LOCKS

TL55	1955 88 All Models	33.00
TL55C	1955 98 All Models	35.00
TL568	1956-58 All Models	33.00
TL613	1959-60 All Models	33.00



DOOR AND IGNITION SETS

DI54	1954 All Models	79.50 set
DI556	1955-56 All Models	79.50 set
DI590	1959-60 All Models	79.50 set

GLOVE BOX AND TRUNK SETS

GT55	1955 All 88 Models	67.00 set
GT55C	1955 All 98 Models	69.00 set
GT590	1959-60 All Models	67.00 set

IGNITION AND DOOR KEY BLANKS

3964624	Ignition and Door Key Blank	
	1937-60 All	4.50 ea.
7002238	Trunk and Glove Box Key Blank	
	1937-60 All	4.50 ea.



MOLDING CLIPS & OTHER FASTENERS

Correct molding clips for Oldsmobiles have been difficult to find new or used. We have reproduced some of the hard to find clips used on select applications for Oldsmobiles. As time goes by we will try and add other clips not yet available. Please check applications carefully, as many of the clips have very limited usage, and are year or model specific.



1937 Belt Molding Clips:
Fits 1937 All Models on Belt Molding.
BMC37 1937 Belt Molding Clip 2.00 ea.

1949-51 Belt Molding Clips:

Fits 1949-50 76 & 88 models, and 1951 88A models, except wagons.

BMC491 Belt Molding Clip 2.50 ea.



Universal Molding Clip:
Replaces the impossible to find original clips that use a bolt-on design molding clip. Can be used

on moldings as wide as 2 1/2" or for moldings as small as 3/4". Trim to correct size needed.

2356 Universal Molding Clip 2.00 ea.

Rear Window Reveal Molding

Clips: These are the clips that are inserted into the rear window rubber channel and attach the rear window molding. Replaces original GM #4657731. Check usage carefully. GM parts book shows the clips are used on the following applications: 1955-56 Hol. Cpe. & Hol. Sedan on upper moldings (9 used), 1958 88 & Super 88 exc. wagons or 2-tone paint on lower moldings (26 used), 1958 88 with 2-tone paint exc. wagons on lower molding (4 used), 1959-60 2 & 4 Door Sedans and Hol. Cpe. on upper molding (9 used)

2628 Rear Window Molding Clip 2.00 ea.



Rear Window Reveal Molding Clip:

This is the other clip used on rear window moldings, replacing GM #4648731. Fits 1954-56 2 and 4 Door Sedan Models only. Uses 12 per car on lower rear window molding.

8731 Rear Window Molding Clip 3.00 ea.



Convertible Top Opening Molding

Clip: Fits All 1955-57 Convertibles on the molding around convertible top opening. Uses 20 clips per car.

TMC557 Convertible Top Molding Clip 3.50 ea.



1955 Front Fender Extension Molding Clip: Used on the Y-shaped molding that wraps around the front lower corner of the fenders.

FFM55 1955 Molding Clip 3.00 ea.



Interior Lower Windshield Garnish Molding Clip: This clip is used on the lower inside windshield reveal molding (between dash and windshield) Fits 1949-50 76 and 88 series and 1951 88A models. 6 clips used per car.
4952S Interior Windshield Garnish Molding Clip 3.00 ea.

1958 Front Fender Molding Clip:
Used on upper and lower front fender moldings on all 1958 models.
FFM58 1958 Molding Clip 3.00 ea.



1958 Quarter Panel/Rear Door Side Chrome Molding Clips: Used to attach the thin side moldings on all 1958 Oldsmobiles.

QD580 1958 Molding Clip 2.00 ea.



1954-56 Under Hood Wire

Retaining Clip: This is the clip used in the engine compartment to retain battery cables & wiring harness. Uses 3-4 clips per car.

2008 Wire Retaining Clip 1954-56 All Models 3.50 ea.



WHS400 1940-50's Wire harness brass strap. Used to attach accessory harness wires to main front harness. Requires 3 or 4 per car. 1.50 ea.



WHC500 Wire Harness Clip. Used to attach accessory wires to frame and other sheet metal areas. Used on 1940-50's Models. Up to 10 per car. .50 ea.



Wire Harness Fastener:

Fits 1957-60 Various applications for wiring, hoses, etc. Check your car for proper application and quantity.

WHF03 Wire Harness Fastener 1957-60 3.50 ea.



Wire Harness Fastener:

Fits 1957-60 Various applications for wiring, hoses, etc. Check your car for proper application and quantity.

WHF04 Wire Harness Fastener 1957-60 3.50 ea.



HARDWARE & FASTENERS



Inside Door Handle and Window Crank Handle Retaining Clips:

11A Fits all 1939-50 Oldsmobiles.
Clip package of 10 4.50

2451A Fits all 1951-60 Oldsmobiles
Clip Package of 10 5.50

Door Handle Tension Spring: Fits all 1937-60 door, vent, and window handles.

1267 Tension Spring 2.50 ea.



Door Panel Repair Tab: Fits all 1935-56 Oldsmobiles. **7585A** Package of 25 11.50



Interior Sheet Metal Screw

Assortment: 100 pieces of 5 different sizes of chrome-plated sheet metal screws. Fits all Models.

2860 Screw package 16.50



1953-60 All Models Cigar Lighter

Element: Limited supply of replacement 12 volt Elements used on 1953-60 All Models

7005278 Lighter Element 6.50 ea.



Nut and Bolt Rubber Insulators:

Used as a cushion under steel washers to eliminate water damage and prevent paint chips. Fits all models. 48 pc set

RP80 Rubber Cushion Set 11.50



Fender Washers: Correct 1 1/4" diameter to accommodate fender bolt 5451 (below). Used on all 1928-53 Models.

768A Washer package of 50 12.00



Fender Bolt: Correct 1" X 7/16" zinc-plated chromate.

5451 Bolt package of 25 11.00



Fender Well Anchor Nut with Tab:

Used mostly on rear body to rear fender area. Fits 1935-48 All, 1950-53 98's.

332 Fender Anchor Nut 3.50 ea.



Slotted Tapping Screw: Used on front fender and radiator sheet metal area. Fits 1940-60.

2219 Tapping Screw (25/pk) 8.50



Tapping Screws: Used to attach various front and rear sheet metal parts. Fits all models.

2972 Screw Package of 50 11.00



Air Cleaner Wing Nut: Correct style cadmium plated wing nut. Fits 1952-60
219210 Wing Nut 4.50 ea.



1949-54 Vent Window Rivet: Used on pivot points for vent windows
R7402 Vent Window Rivet 2.00 ea.



License Plate Bolt and Nut: Fits all models. Set of two bolts and two nuts will service one plate.

1313 License plate fasteners 3.50 4 pc set



Slotted Valve Stem Caps: Correct for all OLDSMOBILES through 1960. Chrome plated as original.

5716 Stem Caps 4.50 set of 5

Brake and Fuel Line Clips



1935-60 Fuel and Brake Line Fasteners: Used to attach lines to frame where there is only one 3/8" line.

3888J Brake and Fuel Line clips 2.00 ea.

1935-60 Fuel and Brake Line Clips:

For models using 2 parallel steel lines that are 1/4" and 5/16" diameter.

1012 Fuel and Brake Line Clip 2.50 ea.



1935-60 Fuel and Brake Line Clips:

For models using 2 parallel steel lines that are 5/16" and 5/16" diameter.

1012A Fuel and Brake Line Clip 2.50 ea.

1935-60 Fuel and Brake Line Clips:

For models using 2 parallel steel lines that are 1/4" and 3/8" diameter.

1013 Fuel and Brake Line Clip 2.50 ea.



GREASE FITTINGS:



9262A Fits all models including springs, upper and lower pivot pins, drag links, etc. 3/8" dia. Package of 10 Fittings 8.50



9257A Fits all models A-Frames, tie rods, u-joints, idler arm, etc. 1/4" dia. Package of 10 Fittings 7.50

DECALS AND ENGINE PAINT

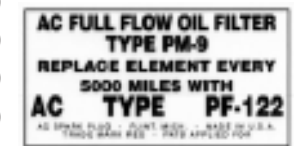
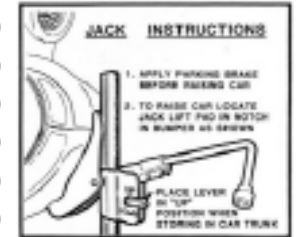
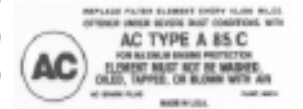
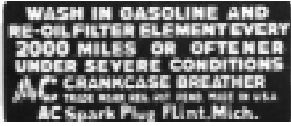

DECALS: All decals reproduced to exact specifications with colors where applicable.

D1	Oil Filler Cap Decal	1935-48 All, 1949-50 6 Cyl.	4.00
D2	Oil Filler Cap Decal	1949-60 All 8 Cylinder	4.00
D3	Air Filter Decal (oil bath)	1935-48 All	4.50
D4	Air Filter Decal (dry element)	1937-48 All	5.00
D5	Air Filter Decal (oil bath)	1949-51 All	4.50
D6	Air Filter Decal (dry element)	1949-56 All	4.50
D7W	Air Filter Decal White (oil bath)	1952-57 All	4.50
D7O	Air Filter Decal Orange (oil bath)	1952-57 All	4.50
D33	Air Filter Maintenance Decal	1959 All	5.00
D36	Air Filter Maintenance Decal	1960 All	5.00
D9	Windshield Washer Canister Decal	1941-60 All	4.50
D12	Jack Instructions Tag with Wire	1937-48 All exc. 1948 98	5.50
D13	Jack Instructions (on Trunk Lid)	1949-53 All	5.00
D14	Jack Instructions (on Trunk Lid)	1954-55 All	5.00
D15	Jack Instructions (on Trunk Lid)	1956-57 All	5.00
D15A	Jack Instructions (on Trunk Lid)	1958 All	5.00
D16	Jack Instructions (on Trunk Lid)	1959 All	5.00
D17	Jack Instructions (on Trunk Lid)	1960 All	5.00
D18	OLDSMOBILE BIG SIX Air Filter Decal	1949-50 6 Cylinder	8.50
D19	Oil Filter Canister Decal PF122	1949-59 All 8 Cylinder	5.50
D20	Power Steering Pump Decal (on lid)	1952-55 All	7.50
D21	Power Steering Pulley Decal	1952-55 All	4.50
D22	OLDSMOBILE ROCKET Air Filter Decal	1957-60 All except J/2	9.50
D23	OLDSMOBILE J/2 ROCKET Air Filter Decal	1957-58 All with J/2	9.50
D24	J/2 Air Filter Maintenance Decal (oil bath)	1957-58 All with J/2	5.50
D25	J/2 Air Filter Maintenance Decal (dry element)	1957-58 All with J/2	5.50
D34	Valve Cover Decals (red letters)	1949-50 All (sold in pairs)	19.00 pr.
D37	Valve Cover Decals (yellow letters)	1952-56 All (sold in pairs)	23.00 pr.
D26	Valve Cover Decals	1957-58 All (sold in pairs)	19.00 pr.
D27	Generator Warning Tag	1937-60 All	3.00
D28	Heater Door Decal (Peel and stick, no longer water type)	1949-56 All	7.50
D35	Heater Emblem Decal	1950 All	9.50
D32	Hydramatic Dip Stick Tag	1951-56 All Hydramatic	5.00

ENGINE PAINT

Engine enamels are color-matched to the original and are made of high quality materials. 3-4 aerosol cans will be enough for an engine, while 6 cans will be necessary for an engine and transmission job.

1937-51 All Models Green Engine Paint	EP50S 16 oz aerosol can	15.50 ea.
1952-56 All Models Green Engine Paint	EP60S 16 oz aerosol can	15.50 ea.
1957-58 All Models Gold Engine Paint	EP70S 16 oz aerosol can	15.50 ea.



Note: All 1940-56 Hydramatic Transmissions should be painted the corresponding green.

SPECIAL NOTE: We can only ship paint to addresses in the United States. Because of air carrier regulations we will not send paint by Air Service or out of the United States under any circumstances.

LITERATURE AND PROMOTIONAL ITEMS



Shop Repair Manuals: We are pleased to offer reprinted Shop Repair Manuals for most Oldsmobiles from 1950-59. These manuals contain hundreds of illustrations and include repair explanations for the engine, carburetor, transmission, electrical system, front and rear suspensions, drive train, brakes, radio, and more. At this time, only the years listed are available.

B50RM	1950-51 Shop Repair Manual	60.00
B52RM	1952 Shop Repair Manual	60.00
B54RM	1954 Shop Repair Manual	60.00
B55RM	1955 Shop Repair Manual	60.00
B56RM	1956 Shop Repair Manual	60.00
B57RM	1957 Shop Repair Manual	60.00

Fisher Body Manuals: Pertain exclusively to body oriented repairs. For example, glass and window channel installations, door-trunk alignment and repairs, wood configurations, wind and water leaks, etc.

BF38	Body Manual 1937-38 All	24.50
BF40	Body Manual 1939-40 All	24.50
BF41	Body Manual 1941-42 All	24.50
BF48	Body Manual 1946-48 All	24.50

Owners Manuals: Quality reprinted Owner's Manuals for selected years. Only years shown available.

OM48	Owner's Manual	1948 All	20.00
OM49	Owner's Manual	1949 All	20.00
OM51	Owner's Manual	1951 All	20.00
OM52	Owner's Manual	1952 All	20.00
OM57	Owner's Manual	1957 All	20.00



Oldsmobile Service Sign. 12" Dia. heavy gauge metal painted royal blue, white and yellow.

OC01	Oldsmobile Service	19.50
-------------	--------------------	-------



52 All Models Color Catalogs: We have located a supply of unused catalogs in their original box. The 1952 All Models catalog has 20 color pages. Normally these pristine catalogs would sell for 35.00 to 40.00. We are offering them at 20.00 ea.

CC52	1952 Olds Color Catalog	20.00
-------------	-------------------------	-------



Miscellaneous Oldsmobile Books

1946-60 Photo Archive book: 126 pages of black and white photos and information covering all Oldsmobile models from 1946-1960.

B207	1946-60 Photo Archive Book	29.95
-------------	----------------------------	-------



Oldsmobile Automobiles 1955-1963:

Published by Brooklands Road Test Books. Covers from 1955-1963 and has 100 pages of road tests, magazine articles, comparisons and technical data for all the popular Oldsmobile models.

B402	Oldsmobile Automobiles 1955-1963 Book	19.95
-------------	---------------------------------------	-------

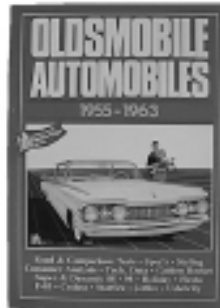

Oldsmobile Fender

Cover: Beautifully stitched black vinyl with gold lettered 'Oldsmobile' script. Foam rubber on the inside.

FC10	'Oldsmobile' Fender Cover	24.50
-------------	---------------------------	-------



Accessory License Plate

Frames:

LF370	1937-60 Accessory License Plate Frame	35.00
--------------	---------------------------------------	-------

LF415C	1937-55 California License Plate Frame. For round corner California plates only.	36.00
---------------	--	-------



NOS mechanical parts are grouped by associated areas I.E. suspension, electrical, etc. New Old Stock must be returned within 7 days of receipt or no refund will be issued.

577802/3	Lower Control Arm Assemblies (with ball joints)	1960 All	210.00 pr.
574433	Lower Control Arm Rubber Bumper	1959-60 All	16.50 ea.
1394944	Lower Control Arm Pivot Pin Package	1936-38 All	22.50 ea.
419668/9	Front Steering Knuckle Supports	1939-53 All	85.00 pr.
1319138	Right Front Wheel Spindle Nut	1957-60 All	8.50 ea.
1319139	Left Front Wheel Spindle Nut	1957-60 All	8.50 ea.
231901	Front Wheel Bearing Grease Seal	1935-38 All	19.50 ea.
577210/11	Lower Ball Joints	1959 All	185.00 pr.
10089	Upper Ball Joints	1957-58 All	85.00 ea.
KB591	King Pin Set	1928-36 All	55.00 set
231848/9	Tie Rod Ends	1937-38 All	49.00 pr.
5552510	Front Shock Absorbers (Delco spirals)	1959-60 98	95.00 pr.
5552511	Rear Shock Absorbers (Delco spirals)	1957-60 98	95.00 pr.
5740061	Rear Air Ride Height Control Valve	1958 with Air Ride	98.00
575037	Front Air Ride Height Control Valve	1958 with Air Ride	85.00
573422	Front Air Ride Pressure Pipe 6 Opening Fitting	1958 with Air Ride	29.00
984347	Accessory Grease Fitting Lubricaps (pk. of 20)	1935-53 All	9.50
5690852	Power Steering Pump Cap	1959-60 All	14.50
5686141	Power Steering Pump Shaft Oil Seal	1959-60 All	9.00
263287	Upper Stearing Shaft Bearing for Horn	1937-38 All	16.50
266218	Horn Cable Wire	1939-47 All	14.50
533600	Differential Case without gears	1958-60 All with anti spin for ratios 40-13, 42-13, 43-15, 43-16	115.00
7450299	Differential Side Bearings	1953-60 All	34.50 ea.
7450646	Differential Rear Pinion Bearing	1957-60 All	39.50
232000	Axle Oil Seals	1937-38 All	19.50 ea.
555632	Right Axle with Bearing	1949-50 76-88, 1951 88A, 1952 All	65.00
555633	Left Axle with Bearing	1949-50 76-88, 1951 88A, 1952 All	65.00
408733	Driveshaft Center Support Bearing Rubber Retainer	1937-38 All	39.50
88506	Driveshaft Center Support Bearing	1937-38 All	39.50
412577	Clutch Release bearing	1939-49 All	38.50
907109	Clutch Pilot Bearing	1933-38 All	19.50
412562	Clutch Pilot Bushing	1939-60 All	16.50
753391	Transmission Mounts	1939-48 8 cylinder w/Standard Trans.	78.00 pr.
7008981	Carburetor Throttle Return Dashpot	1956 2 Barrel Jetaway	16.50
388172	Carburetor Throttle Return Dashpot	1959-60 All 2 Barrel	21.50
388173	Carburetor Throttle Return Dashpot	1959-60 All 4 Barrel	24.50
414882	Fuel Pump Heat Shield	1941-48 All, 1949-50 6 cylinder	29.00
854444	Fuel Pump to Carburetor Inline Filter Assembly	1949-50 8 cylinder	24.50
412691	Crankshaft Balancer	1939-48 All, 1949-50 6 cylinder	65.00
561577	Piston Set with Pins (Standard Size)	1952-53 All	240.00 set
410985	Engine Oil Pump Filter Screen	1939-48 All, 1949-50 6 cylinder	29.50
414512	Valve Lifters	1937-48 All, 1949-50 6 cylinder	11.50 ea.
5231390	Valve Lifters (Standard Size)	1949-51 8 cylinder	9.50 ea.
5230471	Valve Lifters (oversize .001)	1949-51 8 cylinder	9.00 ea.
555648	Rocker Arm Shaft Anchor Bracket & Pin	1949-51 8 cylinder	39.00
408309	Valve Springs	1937-48 All, 1949-50 6 cylinder	7.50 ea.
416604	Rod Bearing Set (Standard Size)	1937-48 6 cylinder	75.00 set
418485	Rod Bearing Set (undersize .002)	1937-48 6 cylinder	75.00 set

418486	Rod Bearing Set (undersize .010)	1937-48 6 cylinder	120.00 set
418487	Rod Bearing Set (undersize .020)	1937-48 6 cylinder	120.00 set
418488	Rod Bearing Set (undersize .030)	1937-48 6 cylinder	120.00 set
417792/3/4/84	Cam Bearing Set	1937-40 6 cylinder	68.00 set
405628	Intake Valves	1934-36 6 cylinder, 1937-48 All	11.50 ea.
408192	Exhaust Valves	1937-48 All	11.50 ea.
567924	Valve Oil Seals	1956-57 All	16.00 set
561692/23	Valve Oil Seals	1958-60 All	24.00 set
414435	Cylinder Head Gasket	1937-48 6 cylinder	39.50
416416	Cylinder Head Gasket	1937-48 8 cylinder	42.50
564029	Cylinder Head Gaskets	1951-52 All	39.00 pr.
565504	Cylinder Head Gaskets	1953-56 All	39.00 pr.
575400	Cylinder head Gaskets	1959 Super 88-98	49.00 pr.
1865978	Distributor Primary Lead Wire	1951-55 All	5.00
1942518	Distributor Primary Lead Wire	1956-60 All	5.00
1838100	Distributor Cap	1928-36 6 cylinder	28.50
1110214	Distributor Assembly (New)	1946-48 6 cylinder	145.00
1110824	Distributor Assembly (New)	1951-53 All	145.00
4909335	Windshield Washer Top Cover and Switch Assembly	1959 Dyn 88 w/1 speed Wipers	58.00
4761427	Windshield Wiper & Washer Dash Control & Chrome Housing	1959 98 w/2 speed wipers	22.00
414247	Exhaust Pipe Flange Gasket	1935-48 All, 1949-50 6 cylinder	12.50
563300	Right Side Exhaust Manifold (reconditioned take-off)	1954-56 All	80.00
573324	Right Exhaust Manifold (reconditioned take-off)	1959-60 All	79.00
573324/5	Exhaust Manifolds (reconditioned take-offs)	1959-60 All	165.00 pr.
1116591	Ignition Switch	1959-60 All	38.00
1998681	Brake Stoplight Switch	1959 All Power Brake	18.50
1998742	Brake Stoplight Switch	1960 All Power Brake	16.50
1997810	Back Up-Neutral Safety Switch	1946-48 Hydramatic Trans.	22.00
5939582	Neutral Safety Switch	1950 H.T. with Back-up Lamps	27.50
1998125	Neutral Safety Switch	1956 Jetaway Transmission	35.00
3126120	Heater Core (reconditioned)	1950-52 All	59.00
3130917	Heater Core (reconditioned)	1953 All	59.00
3127971	Heater Resistor Coil	1951 Super 88-98, 1952 All	19.50
575930	Heater Fan Switch on Dash	1959-60 exc. Air Conditioning	29.00
572256	Water Pump Pulley (3 Groove)	1958 Air Ride exc. Air Conditioning	48.00
574814	Thermostat Housing	1959-60 2 Barrel	26.50
1998740	Temperature Sending Unit (in block)	1959-60 All	29.50
1344672	Speedometer Gear (19 teeth 33 pitch)	1951 -55 All Hydramatic	28.50
417984	Front and Rear Brake Shoe Set (4 wheels)	1937-40 6 cyl., 1941 66-68	95.00
5450406/7	Wheel Cylinders	1935-36 All Front, 1935-37 All Rear	85.00 pr.
412553	Front Brake Drum & Hub (turned & reconditioned)	1937-41 6 cyl., 1941 68 series	99.00
412556	Rear Brake Drums (turned & reconditioned)	1937-40 6 cyl., 41 66-68, 1942-50 66-68-76	89.00 ea.
556944/5	Front Brake Drum & Hub (turned & reconditioned)	1949-52 All 8 cylinder	125.00 ea.
565964	Rear Brake Drums (turned & reconditioned)	1952-56 All	95.00 ea.
565960	Right Front Brake Drum & Hub (turned & reconditioned)	1953-56 All	128.00 ea.
565961	Left Front Brake Drum & Hub (turned & reconditioned)	1953-56 All	128.00 ea.
1162771	Generator Assembly (New)	1949-51 8 Cylinder	149.00
566693	Generator Support Bracket	1953-56 All	18.50
571087	Generator Support Bracket	1957-58 All exc. Air Cond. or Air Ride	18.50
574874	Generator Support Bracket	1959-60 All exc. Air Conditioning	18.50

820052	Starter Switch (on top of starter)	1935-48 All Foot Starter	16.50
1107930	Starter Assembly (rebuilt and restored)	1942-47 8 cyl., 1948 All	165.00
1107982	Starter Assembly (rebuilt and restored)	1949-51 8 cyl.	179.00
1107623	Starter Assembly (rebuilt and restored)	1954-55 All	179.00
1116775	Horn Relay (Delco)	1941-52 All	45.00
1999631	Horn Assembly Low Pitch	1937-38 All, 1941 All, 1949-52 All	78.00
1119635	Voltage Regulator	1957 w/AC, 1958-60 All	79.50
1863373	Ignition Coil (Delco)	1935-36 All	85.00
1115380	Ignition Coil (Delco)	1948-52 All	79.00
4902201	Right Power Window Motor for Door or Quarter Window (less gear)	1954-59 round type	129.00
1517785	Electric Shift Indicator (N Dr S Lo R)	1953 All	35.00
1518960	Dash Gas Gauge	1958 All	18.50

NOS Body Parts are grouped earliest to latest applications.

2330	Headlight Bulb	1934-39 All	7.50 ea.
403628	Radiator Shell Emblem (excellent take-off)	1934 All	65.00
920696	Tail Light Lens	1937-38 6 Cylinder, 1938 8 Cylinder	18.50 ea.
984397	Accessory Grease Fittings Lubricaps (package of 20)	1937-53 All	9.50
4093396	Glove Box Lock Assembly with Keys	1939 70-80 series	37.00
4131755	Door Lock Cylinder Retaining Clips	1939-40 70-90, 1941-48 All exc. 1948 98	3.00 ea.
412734/5	Hood Side Moldings	1940 70-90 Series	65.00 pair
416068/9	Rocker Panel Moldings	1941 Series 66-68 All Models	128.00 pr.
416072/3	Rocker Panel Moldings	1941 Series 76-78 All Models	128.00 pr.
418554	Hood Emblem (nice restored)	1946-47 66-68-76-78	48.00
926701/2	Fog Lamp Assemblies with wiring (no other parts)	1946-48 All except 1948 98	120.00 pr.
419674	Hood Ledge Rubber Bumper (uses 2)	1946-48 All, 1949 98	3.00 pr.
419909	Left Front Bumper Guard	1948 98, 1949 All, 1950 76-88, 1951 88A	145.00
4580436/7	Lower Chrome Gravel Shields below Doors	1949 76-88 4 Dr., 1950 Deluxe SW	49.00 pr.
4151760	Outside Door Handle Push Button and Shaft with keys	1949-53 All except 1949 98	28.50 ea.
4168321	Left Outside Door Handle	1949-50 76-88, 1951 Super 88, 1952-53 Hol. Cpe & Conv	45.00
4577073	Left Rear Door 'FUTURAMIC' Molding	1950 76-88 4 Doors	42.00
4578128	Left Quarter Rubber Gravel Shield	1950 76-88 2 Doors	120.00
558368/9	Rear Fender "FUTURAMIC" Moldings	1950 98 2 Doors	120.00 pr.
4586939/40	Rear Quarter/Door Diagonal Chrome Moldings	1951 Super 88	49.00 pr.
1917579	Turn Signal Lever and Knob	1951 Super 88-88A without clock in wheel	32.00
7003280	Cigar Lighter Knob and Element	1951-52 All	19.00
4587367/8	Rear Door Chrome Moldings	1951-52 Super 88 4 Doors	42.00 pr.
4604439	Left Door Striker Assembly	1951 Super 88, 1952-53 All	24.50
88270	Right Windshield Wiper Transmission & Cable	1951 Super 88, 1952-53 exc. Fiesta	55.00
1921914	Turn Signal Lever and Knob	1952 88-Super 88	32.00
561567	Left 'NINETY' Door or Quarter Script	1952-53 98	25.00
1582180	Speedometer Assembly w/ new shift indicator (mileage 84378)	1953 All	58.00
5944028	Park Light Chrome Bezels	1953 All	24.50 ea.
4619034/5	'88' Door Panel Emblems	1953 Super 88 Hol. Cpe & Conv, 1954 88s	39.00 pr.
563809	Full Disc Wheel Cover Rim Stone Plugs	1953-54 All	2.00 ea.
4636064/5	'88' Rear Door or Quarter Panel Emblems	1954 Super 88	58.00 pr.
565126	Hood Emblem Bar and Ring	1954 All	98.00
563937	Hood Edge Chrome Molding	1954 All	78.00
5942074/5	License Lamp Chrome Rims	1954 All	22.00 pr.
565396	Trunk 'OLDSMOBILE' Script	1954 98	48.00

564477	Left Rocker Panel Molding	1954 Super 88	110.00
565179	Trunk Emblem	1954-55 Super 88 & 88	138.00
9701140	Small Disc Hub Caps	1954-55 All	24.00 ea.
1550204	Dash Radio Grille Upper & Lower Grille Assembly	1954-55 All	120.00
897632	License Lamp Assembly	1955 All	48.00
4656944/5	Rear Quarter V-shaped Moldings (buffed take-offs)	1955 Super 88-88 Holiday Coupes	118.00 pr.
566926/7	Front Fender Chrome Moldings	1955 All Holiday Sedan	95.00 pr.
566342/3	Rocker Panel Moldings	1955 98 4 Door	135.00 pair
4657964/5	Door Weatherstrips around Door (GM)	1955-56 Convertibles	110.00 pair
567932	Grille Halves	1956 All	120.00 pair
567698	Right Front Bumper Guard	1956 All	32.00
568581	Jack Assembly	1956-57 All	145.00
4694344	4 Button Left Front Door Power Window Switch (nice working take-off)	1957 All	95.00
989003	Deluxe AM Radio (nice take-off, sold as is)	1957 All	98.00
4233081	Center Roof Dome Light Lens	1957-60 Wagon Models	14.50
5948955	Left Headlight cast Chrome Bezel (excellent take-off)	1958 All	65.00
572096	Right Front Fender Hood Extension Molding (excellent take-off)	1958 All	78.00
571920	Right Front Bumper Guard	1958 All	48.00
5949574	Upper Tail Light Cast Chrome Housing (nice take-off)	1958 All	55.00 ea.
4755545	Left Rear Quarter Blister Molding	1959 Super 88-98	48.00
576621	Left Front Fender Edge Small Cast Ornament	1959 Super 88-88	20.00
575598	Right Front Fender Top Rocket (excellent NOS quality Take-off)	1959 All	48.00
4762937	Trunk Handle Assembly (excellent take-off)	1959 All	65.00
5950077	Tail Light Lenses	1959 88's	32.00 ea.

Part	Page	Part	Page	Part	Page
A-B		G		O-P	
Antenna Parts	16	Gasket, Cowl Vent Rubber	30	Ornament, Bumper Exhaust	16
Ash Trays and Bezels	13	Gasket, Door Handle Rubber	19	Pad, Brake-Clutch-Park Brake Rubber	19
Battery Hold-down Parts	36	Gasket, Door and Trunk, Rubber	31	Pad, Rubber Mounting	22
Bearing, Wheel	44	Gasket, Engine Overhaul	37-38	Pad, Windshield Wiper Transmission	23
Belt, Fan & Power Steering	49	Gasket, Park, Back-up, Tail Light	4-5	Pin Package, Suspension	44
Bead, 1957 Tail Light	30	Glove Compartment Box	18	Pistons and Rings, Engine	39
Bezel, Dome Light Chrome	12	Grease Fittings	52	Plate, Fisher Body Name	14
Bezel, Headlight & Back-up Chrome	15	Grommet, Bumper Bar Rubber	21	Plug, Body & Floor Pan	23
Body Mounts	45	Grommet, Firewall Rubber	23	Pump, Engine Fuel, Oil, Water	32
Bolt, Bumper	16	Grommet, Gasoline Filler Rubber	30	Q-R-S	
Bolt, Fender Attaching	52	H		Reflector, Tail Light Lens	5
Bolt, Rear Spring Shackle Eyelet	46	Handle, Convertible Top Chrome	11	Rocker Panel Moldings	15
Boot, Gear Shift Rubber	21	Handles, Chrome Door, Window, Vent	11	Rubber Channel, Front, Rear Window	27
Brake Parts	33-34	Handle, Outside Door Chrome	11	Screw, Sheet Metal Tapping	52
Bulb, Dash and T-3 Headlamp	50	Hardware	52	Scripts, Exterior Chrome	7-10
Bumper, Door, Trunk Rubber	21	Harmonic Balancer	32	Seal, Front Wheel-Axle-Pinion	44
Bumper, Gas Door Rubber	21	Heater Control Valve	49	Seal, Suspension Arm & Pivot	44
Bumper, Hood to Fender Rubber	21	Hinge, Chrome Trunk	17	Sealing Strip, Quarter Window Rubber	26
Bumper, Seat Back Rubber	13	Hood Insulation	16	Seals, Door Drain Hole Rubber	30
Bushing, Control Arm Rubber	45	Horn Cap Plastic Center	14	Seals, Door Hinge Pillar (1950)	31
Bushing, Rear Spring Shackle Rubber	46	Hose, Flexible Fuel Line	40	Seals, Front Fender A-Frame	45
Bushing, Stabilizer Bar Rubber	43	Hose, Radiator & Heater	48	Sending Unit, Fuel Tank	41
C		Hose, Transmission Coolant Line	41	Sending Unit, Oil & Temperature	41
Cables, Battery	36	Housing, Courtesy Lamp	12	Sheet Metal Screw Package, Interior	52
Cam, Engine and Bearings	39	Housing, Thermostat	49	Shock Absorber, Suspension	43
Cap, Gasoline Filler	17	Hub Caps, Chrome	2	Sill Plate, Door Step	14
Cap, Radiator Filler	49	Hub Cap, Retaining Clips	2	Sleeve, Fresh Air Duct Rubber	30
Carburetors	32	I-J-K		Speedometer Cable	34
Carburetors, Overhaul Kit-Floats	40	Idler Arm, Steering	44	Stabilizer Link Kit, Suspension	43
Clamp, Radiator Heater Hose	48	Ignition Wire Set	35	Steering Coupling, Power	42
Clip, Inside Crank Handle	52	Insert, Power Steering Plastic	14	Steering Wheels	14
Clip, Wheel Cover Retaining	2	Insulator, Axle Housing Rubber	46	T-U-V	
Clip, Gas & Brake Line	51	Insulator, Nut & Bolt Rubber	52	Terminal Board, Wire Junction	47
Clip, Universal Molding	51	Insulator, Rear Spring Rubber Pad	46	Thermostat, Cooling System	49
Coil Springs, Suspension	46	Kick Panel, Cardboard	20	Tie Rod End, Suspension	44
Cushion, Horn Button Rubber	30	Knob, Turn Signal, Shift, Plastic	13	Transmission Seal and Gasket	41
Cylinder, Window and Seat Hydraulic	42	L-M		Trunk Cardboard Kits	20
D-E-F		Lacing, Hood to Cowl	23	Trunk Material	20
Decals	53	Lamp Bulbs	50	Tube, Cowl Drain Rubber	22
Deflector, Chrome Exhaust	16	Leaf Springs, Rear Suspension	46	Tune-up Kit, Engine	35
Distributor	35	Lens, Courtesy Lamp Plastic	12	Universal Joint, Driveshaft	45
Door Sill Plate	14	Lens, Park-Tail-Back-up Plastic	4-5	Valve Stem, Tire	2
Drain Tubes, Quarter Window Area	26	Lifters, Valve	38	Valves, Intake and Exhaust	39
Electrical Parts	34	Link, Door Check	17	Voltage Regulator	37
Element, Cigar Lighter	52	Literature	54	W-X-Y-Z	
Emblem, Exterior Chrome	7-10	Locks and Keys, Ignition, Trunk	50	Washer Jar Lid	17
Emblem, Hood & Trunk Plastic	6	Manuals, Shop-Owners-Parts	54	Weatherstripping, Conv. Top Rubber	26
Engine Paint	53	Mats, Rubber Floor	19	Weatherstripping, Door Rubber	28-29
Engine Parts	37-39	Mirror, Side & Rear View	3	Weatherstripping, Rear Window Rubber	27
Exhaust Heat Riser and Gaskets	42	Mirror, Visor Vanity	3	Weatherstripping, Auxiliary Door Rubber	29
Fasteners	51-52	Motor, Windshield Wiper	32	Weatherstripping, Roof Rail Rubber	28
Fender Cover	54	Mount, Driveshaft Support & Bearing	45	Weatherstripping, Trunk Rubber	31
Fender Skirt Rubber	30	Mount, Engine & Transmission	41	Weatherstripping, Vent Window Rubber	25
Ferrule, Door Lock Button	11	N		Welt, Rear Fender Beaded	30
Filter, Engine Oil	41	New Old Stock Parts	55-58	Wheel Cylinders & Kits, Brake	33
Firewall Insulator	18	Nut, Spare Tire Retaining	20	Windshield Wiper Blades	18
Fuel Pump	32	Nut, Wheel Lug	46	Window Channel & Kits	24
Fuel Tank Unit	41			Wire Holder, Spark Plug	35
				Wiring Harnesses	47

