

# MADISOUND SPEAKER COMPONENTS

Audiophile Price List — May 2006

Central Time Hours: 9:00 a.m. to 5:00 p.m. Monday - Friday; 9:00 a.m. to 3:00 p.m. Saturday

Madisound Air Core Inductors					
mH	Size	Wire gauge	DCR $\Omega$	Power Watts	Cost
.10	SB/MB	20/19	.1 / .1	100	<b>\$2.40</b>
.15	SB/MB	20/19	.1 / .1	100	<b>2.50</b>
.20	SB/MB	20/19	.2 / .17	100	<b>2.70</b>
.22	MB	19	.18	100	<b>2.70</b>
.25	SB/MB	20/19	.31 / .2	100	<b>2.75</b>
.30	SB/MB	20/19	.34 / .3	100	<b>2.95</b>
.33	MB	19	.3	100	<b>3.10</b>
.35	SB/MB	20/19	.38 / .3	100	<b>3.10</b>
.40	SB/MB	20/19	.4 / .3	100	<b>3.20</b>
.45	SB/MB	20/19	.43 / .3	100	<b>3.25</b>
.47	MB	19	.34	100	<b>3.25</b>
.50	SB/MB	20/19	.44 / .35	100	<b>3.35</b>
.55	MB	19	.37	100	<b>3.45</b>
.56	SB	20	.48	100	<b>3.45</b>
.60	SB/MB	20/19	.5 / .37	100	<b>3.60</b>
.67	SB/MB	20/19	.53 / .4	100	<b>3.65</b>
.70	MB	19	.41	100	<b>3.85</b>
.75	MB	19	.43	100	<b>4.00</b>
.80	SB/MB	22/19	.88 / .45	100	<b>4.20</b>
.85	MB	19	.48	100	<b>4.30</b>
.90	MB	19	.5	100	<b>4.35</b>
1.00	MB	19	.5	150	<b>4.70</b>
1.25	MB	19	.7	150	<b>5.00</b>
1.50	MB	19	.75	150	<b>5.40</b>
1.75	LB	19	.8	150	<b>6.50</b>
1.80	MB	19	.82	150	<b>6.75</b>
2.00	LB	19	.9	150	<b>7.10</b>
2.25	LB	19	.95	150	<b>7.30</b>
2.50	LB	19	1.0	150	<b>7.70</b>
2.75	LB	19	1.05	150	<b>8.00</b>
3.00	LB	19	1.1	150	<b>8.30</b>
3.50	LB	19	1.2	150	<b>9.00</b>
4.00	LB	19	1.3	150	<b>9.50</b>



Surplus Capacitors		
1.9 mfd	WestCap Mylar, 450VDC, Axial, yellow	<b>.30</b>
2.0 mfd	Mylar, 10%, 200V, green	<b>.35</b>
2.2 mfd	Ero mylar, 10%, 63V PC mount	<b>.30</b>
2.7 mfd	Panasonic mylar, 10%, 250V long leads	<b>.30</b>
2.7 mfd	Richey mylar, 250V, Dipped, Red	<b>.30</b>
3.0 mfd	T.I. mylar 10% 100V long leads	<b>.30</b>
3.3 mfd	Panasonic Polyprop. 10% 200V radial	<b>.60</b>
10.0 mfd	TYEE Polyprop. 100V, 30 x 27 x 18mm	<b>.90</b>

Wire-Wound Sand Cast Resistors	
15 Watt 12.5mm T x 12mm W x 46.5mm L	
25 Watt 13mm T x 14.5mm W x 60mm L	
1, 1.5, 2.2.5, 3, 3.5, 4, 4.5, 5, 5.5, 6.6, 5, 7, 7.5, 8.9, 10, 14, 23 $\Omega$ 15 W 10%	<b>\$.45 each</b>
2.2, 2.7, 3.3, 3.9, 4.7, 5.6, 6.8, 8.2, 10, 12, 15, 20, 25 $\Omega$ 25 Watt 10%	<b>.65 each</b>

Eagle - Metal Oxide Film Non-Inductive Resistors	
5%, 10Watt, 8.5mm $\varnothing$ x 32mmL, 33mm leads	
1, 1.5, 2.2, 2.5, 2.7, 3.3, 3.5, 4, 4.7, 5, 5.6, 6.6, 8, 7, 8, 9, 10, 12, 14, 15, 16, 20, 25, 30, 50 $\Omega$	<b>\$1.20 each</b>



Circuit Boards for Crossovers, Soldered Lugs, Glass Epoxy			
12 dB 2-way (64B)	<b>\$5.50</b>	12 dB 3-way (92B)	<b>\$9.00</b>
18 dB 2-way (BFB)	<b>8.50</b>	Matrix Double	<b>14.00</b>
Matrix	<b>7.00</b>		

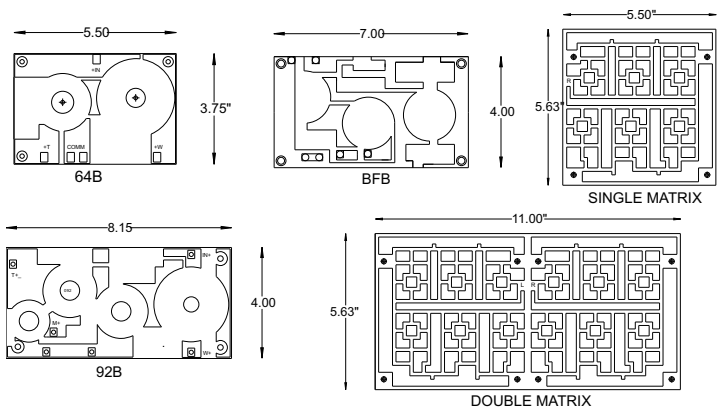

Autosound Steel Grills with Mounting Rings					
4.5"	<b>\$3.50</b>	6.5"	<b>\$5.00</b>	10"	<b>\$7.00</b>
5.25"	<b>4.00</b>	8"	<b>6.00</b>	12"	<b>10.00</b>



Madisound Iron Core Inductors				
4.5	LB	18	.75	<b>\$9.75</b>
5.0	LB	18	.80	<b>10.00</b>
6.0	LB	18	1.0	<b>10.65</b>
7.0	LB	18	1.2	<b>11.80</b>
8.0	LB	18	1.4	<b>12.40</b>
10.0	LB	18	1.4	<b>14.00</b>
†SB bobbin 38mm $\varnothing$ x 20mm tall; MB bobbin 48mm $\varnothing$ x 23mm tall				
LB bobbin 59mm $\varnothing$ x 32mm tall; XLB bobbin 54mm $\varnothing$ x 55mm tall				

MADISOUND SPEAKER COMPONENTS, INC.  
 8608 UNIVERSITY GREEN  
 P.O. BOX 44283  
 MADISON, WI 53744-4283 U.S.A.  
 TEL: 608-831-3433 FAX: 608-831-3771  
 e-mail: info@madisound.com  
 Web Page: http://www.madisound.com

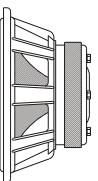
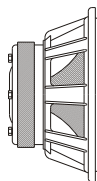

# MADISOUND LOW RESISTANCE INDUCTORS

MADISOUND is pleased to announce that we are now stocking SIDEWINDER and SLEDGEHAMMER Audio Inductors. These are audiophile grade inductors using 16 gauge wire with the following specifications:

Hard drawn copper for maximum conductivity.

Nylon-Polypropylene coating for maximum scuff and abrasion protection.

Better than 101.3 % of National Electrical and Manufacturing Association (NEMA) standard sample.

Power Handling capacity: more than 350 watts before saturation.



## SIDEWINDER AUDIO INDUCTORS - 16 AWG

### AIR CORE INDUCTORS

Bobbin: 48mmØ x 23mm tall

.1 mH	.1 Ω	\$3.55
.15	.11	3.65
.20	.14	4.00
.22	.14	4.10
.25	.15	4.25
.30	.16	4.80
.33	.18	5.10
.39	.18	5.45
.45	.2	5.75

### AIR CORE INDUCTORS

Bobbin: 59mmØ x 32mm tall

.50mH	.22	\$7.00
.55	.23	7.35
.60	.24	7.50
.65	.27	7.85
.70	.28	8.20
.75	.29	8.45
.80	.30	8.70
.85	.31	8.85
.90	.33	9.10

### AIR CORE INDUCTORS

Bobbin: 59mmØ x 32mm tall

1.00mH	.34	\$9.60
1.25	.38	10.50
1.50	.43	11.80
1.80	.47	12.50
2.00	.52	13.50
2.25	.54	13.80
2.50	.59	14.30
Bobbin: 54mmØ x 55mm tall		
3.00	.72	14.70
3.50	.76	15.10

## SLEDGEHAMMER STEEL LAMINATE INDUCTORS - 15 AWG

MADISOUND is pleased to offer a line of LOW distortion inductors. We are utilizing the good magnetic characteristics of high permeable steel alloy to give you inductors with high power capability, low DCR and low distortion. The inductors show significantly lower distortion in the low frequencies and will give cleaner sound reproduction for bass drivers, especially subwoofers.

Just as you would use polypropylene capacitors for a noticeably cleaner sound in your midranges and tweeters, Madisound Sledgehammer Steel inductors will give you noticeably clearer bass. Sledgehammer Steel Laminate inductors use hard drawn 15 gauge copper wire for maximum conductivity and low DC resistance.

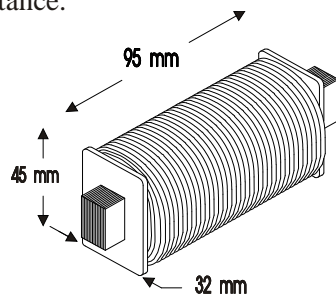

1.0mH to 3.7mH: 32mm x 45mm x 48mm

mH	DCR	Price
Dim: 32mm x 45mm x 48mm		
1.0	.100	\$8.65
1.25	.120	9.25
1.5	.140	10.05
2.0	.156	10.30
2.25	.162	10.90
2.5	.164	11.20
2.7	.168	11.90
3.0	.178	12.05
3.3	.185	12.75
3.7	.200	13.45

mH	DCR	Price
Dim: 32mm x 45mm x 95mm		
4.0	.210	\$14.70
5.0	.242	16.00
5.5	.257	16.25
6.0	.272	16.65
7.0	.307	17.55
8.0	.345	18.55
10.0	.376	20.25
12.0	.426	21.75
15.0	.505	24.00
18.0	.550	24.55
20.0	.595	27.15



Values between sizes listed are also available. Add 20% to cost of value larger than your requirement.



# GOERTZ AIR CORE FOIL INDUCTORS

MADISOUND is pleased to offer Goertz air core foil inductors. Foil inductors have obvious advantages over wire wound inductors in terms of improved electrical and sonic characteristics.

- 1" wide x 0.003" 14AWG
- 99.99% pure copper foil
- 0.002" thick polypropylene film coating
- Negligible skin-effect below 100kHz
- Flat inductive reactance from 5Hz through 50kHz
- No saturation distortion
- Extremely low stored charge
- Cool operation, good heat dissipation
- High winding tension and vacuum fusing reduces FM distortion
- Negligible power loss due to skin-effect
- Tolerance 2.5%



## 14 AWG COPPER

mH	DCR	Dia. In.	Price	mH	DCR	Dia. In.	Price
0.10	.050	1.6	\$8.40	0.75	.162	2.5	\$15.40
0.15	.054	1.7	\$9.25	0.82	.175	2.6	\$16.10
0.22	.071	1.8	\$9.75	1.00	.188	2.7	\$17.10
0.25	.076	1.8	\$9.95	1.20	.220	2.8	\$18.90
0.27	.078	1.9	\$10.10	1.50	.251	3.0	\$20.10
0.30	.082	2.0	\$10.45	1.80	.300	3.2	\$21.60
0.33	.083	2.0	\$10.95	2.00	.315	3.3	\$23.10
0.39	.095	2.1	\$12.00	2.20	.332	3.4	\$24.55
0.47	.110	2.2	\$12.30	2.70	.370	3.5	\$26.30
0.50	.118	2.2	\$12.90	3.30	.421	3.7	\$29.25
0.56	.130	2.3	\$13.25	3.90	.477	3.9	\$31.05
0.62	.148	2.3	\$13.95	4.70	.547	4.1	\$36.75
0.68	.154	2.4	\$14.75	6.00	.658	4.2	\$40.80

## 16 AWG COPPER

mH	DCR	Dia. In.	Price
0.10	.078	1.3	\$7.25
0.15	.086	1.4	\$7.45
0.22	.112	1.5	\$7.80
0.25	.120	1.6	\$7.85
0.27	.124	1.6	\$7.95
0.30	.129	1.8	\$8.20
0.33	.130	1.9	\$8.40
0.39	.150	2.0	\$8.90
0.47	.173	2.1	\$9.25
0.50	.190	2.1	\$9.80
0.56	.204	2.2	\$10.15
0.62	.276	2.2	\$10.60
0.68	.242	2.3	\$11.10
0.75	.250	2.4	\$11.35
0.82	.276	2.5	\$11.65
1.00	.295	2.6	\$12.15
1.20	.343	2.7	\$12.90
1.50	.394	2.9	\$13.80
1.80	.471	3.1	\$14.65
2.00	.497	3.2	\$15.85
2.20	.522	3.3	\$16.75
2.70	.583	3.4	\$18.00
3.30	.661	3.6	\$20.00

## 12 AWG COPPER

mH	DCR	Dia. In.	Price
0.10	.027	1.7	\$12.00
0.15	.032	1.8	\$13.35
0.22	.045	1.9	\$14.75
0.25	.047	2.0	\$15.50
0.27	.049	2.0	\$16.00
0.30	.052	2.0	\$16.80
0.33	.053	2.1	\$18.40
0.39	.087	2.2	\$19.65
0.47	.070	2.3	\$20.40
0.50	.075	2.4	\$21.75
0.56	.083	2.4	\$23.25
0.62	.091	2.4	\$24.30
0.68	.098	2.5	\$25.50
0.75	.105	2.6	\$26.20
0.82	.111	2.7	\$26.85
1.00	.120	2.8	\$28.15
1.20	.141	2.9	\$30.50
1.50	.160	3.1	\$33.50
1.80	.191	3.3	\$35.00
2.00	.202	3.4	\$38.40
3.90	.304	4.1	\$54.25
4.70	.348	4.4	\$65.55
6.00	.415	4.7	\$74.90

## Air Core Foil Inductors

Since we introduced our Air Core Inductors in 1997 they have become standard fixtures in many of the Worlds finest speakers, and thousand of audiophiles have improved their sound by personally upgrading their crossover circuits with our products.

Alpha-Core developed the combination of high grade OFC copper with polypropylene film as the dielectric, wound onto a non-hygroscopic core able to endure the sometimes high working temperature without long term shrinkage. We knew that a loose center will allow relative motion of layers due to electromagnetic forces, leading to FM distortion, so we chose LEXAN™ a high strength, super stable engineering resin for our cores.

We also developed the vacuum fusing process in order to further preserve the long-term integrity of our inductors.

Research has no limits, so throughout the years we have worked on improving our product and proprietary manufacturing equipment. As a result we are now winding our inductors even tighter, to closer tolerances and at increased productivity. Inductors are calibrated within 2.5% of nominal, wound with superior tightness and fused at both ends, hermetically protecting the conductor (be it copper or fine silver) against tarnishing with time.

The copper foil inductors cannot be wound down and we are not able to special order values that are not listed here. If you need a special value or one of the silver coils, please order directly from Alpha-Core.

# PERFECT LAY WINDING Air Core Inductors

MADISOUND is now stocking **PERFECT LAY WINDING** audio inductors from Solen Engineering. These are audio grade inductors using 14 gauge wire with the following specifications:

- Perfect Lay Hexagonal Winding. Winding Space Factor: 86.7%
- Oxygen Content: Less than 200 parts per million on surface.
- Insulation: 130 degree centigrade Single coating Nylon-Polyurethane.
- Computer Optimized Coil Dimension.
- Encapsulation: Varnish dip coating with 4 nylon ties.
- No Saturation distortion: Test voltage 1500 VAC
- No Hysteresis distortion: Test voltage 1500 VAX
- Inductance tolerance: within 1% of value listed.
- Conductivity: Better than 101.5% of National Electrical and Manufacturing Association (NEMA) standard sample.
- Wire Diameter: .064 inches; 1.63 mm. High Purity Annealed Copper.



mH	DCΩ	Ht"	Ø"	Price	mH	DCΩ	Ht"	Ø"	Price	mH	DCΩ	Ht"	Ø"	Price
0.22	.08	.56	2.25	\$8.60	0.91	.20	.75	3.0	\$16.95	3.0	.42	.88	3.5	\$30.05
0.33	.10	.63	2.5	10.20	1.0	.21	.75	3.0	18.00	3.3	.45	1.0	4.0	30.30
0.39	.11	.63	2.5	11.30	1.2	.26	.75	3.0	18.10	4.0	.50	1.0	4.0	33.95
0.47	.13	.63	2.5	12.05	1.5	.28	.75	3.0	20.80	4.5	.56	1.0	4.0	35.60
0.56	.15	.63	2.5	13.35	1.8	.30	.88	3.5	23.20	5.0	.59	1.0	4.0	37.50
0.62	.16	.63	2.5	14.15	2.0	.31	.88	3.5	24.75	5.5	.63	1.0	4.0	39.55
0.68	.17	.75	3.0	14.25	2.25	.33	.88	3.5	26.15	6.0	.67	1.0	4.0	42.15
0.75	.18	.75	3.0	15.15	2.5	.36	.88	3.5	26.90	6.7	.71	1.3	5.0	42.40
0.82	.19	.75	3.0	15.95	2.75	.39	.88	3.5	28.20	21.0	1.4	1.5	6.0	75.75

# CHATEAUROUX Polypropylene Solen Fast Caps

We are pleased to announce that we now have in stock **CHATEAUROUX METALLIZED POLYPROPYLENE CAPACITORS** of exceptional quality and excellent price. This type of dielectric has been characterized by Walter Jung as "outstanding" when compared with all other dielectrics in the areas of:

## DISSIPATION FACTOR PERCENTAGE-DIELECTRIC ABSORPTION PERCENTAGE-STABILITY

- Low dissipation factor
- Low dielectric absorption factor
- High insulation resistance
- High frequency and temperature stability
- Good self healing characteristics of polypropylene dielectric
- High Current Capacity
- Excellent Over voltage and Pulse handling capability



- Low self inductance
- Low equivalent series resistance
- Excellent stability
- Leads: Tinned pure copper
- Superior high frequency characteristics
- High Ionization level
- Dissipation factor @ 20o C: Less than .01 %.
- Dielectric: Polypropylene Film.
- Working Voltage: 400 VDC or higher.
- Test Voltage: 2.15 times rated voltage

Dimensions in mm:	8 ufd: 24 D, 38 L	35 ufd: 40 D, 53 L	80 ufd: 54 D, 65 L
1 ufd: 13 D, 23 L	12 ufd: 29 D, 38 L	40 ufd: 40D, 60 L	100 ufd: 56 D, 72 L
2 ufd: 16 D, 25 L	15 ufd: 29 D, 45 L	50 ufd: 45 D, 60 L	120 ufd: 61 D, 72 L
4 ufd: 18 D, 33 L	18 ufd: 31D, 45 L	60 ufd: 47 D, 65 L	150 ufd: 62 D, 85 L
6 ufd: 23D, 33 L	25 ufd: 34 D, 53 L	70 ufd: 49 D, 65 L	200 ufd: 62 D, 110 L

1.0 ufd	\$1.55	5.0 ufd	\$2.80	15.0 ufd	\$5.65	50.0 ufd	\$13.85
1.5	1.75	5.6	2.95	18.0	6.30	60.0	16.30
2.0	1.95	6.0	3.05	20.0	6.40	70.0	18.00
2.2	2.05	6.8	3.30	22.0	6.60	80.0	20.35
2.5	2.10	7.0	3.35	25.0	8.35	100.0	25.10
3.0	2.20	8.0	4.05	30.0	9.50	120.0	30.30
3.3	2.25	9.0	4.40	35.0	10.55	150.0	35.10
4.0	2.50	10.0	4.50	40.0	11.65	200.0	45.30
4.7	2.70	12.0	5.00	45.0	12.90		

Pairs matched to within 1% of each other; add 10%.

# MUSICAP by H O V L A N D

Madisound is pleased to offer Hovland MusiCaps, film and foil polypropylene capacitors, for the speaker builder who can settle for nothing but the best in sound reproduction. MusiCaps have quickly become the standard for extremely high end audio systems, allowing speakers to achieve their ultimate level of performance. MusiCaps provide a dramatic improvement in clarity, focus and dynamics. Although MusiCaps are expensive, the degree of improvement is a value compared to the cost of high end cables and interconnects. Hovland MusiCaps are the component of choice when musical realism is your goal.

F E A T U R E S

- Separate layers of polypropylene film & conductive foil, deliver superior clarity of reproduction
- Custom stranded 16 gauge silver-plated copper leads - no copper oxidation to ever degrade the sound
- Lead-free silver-bearing solder used in tinning and attachment of leads
- Tight  $\pm 5\%$  tolerances
- Hand Soldered lead termination
- Extremely low DA, DF and ESR
- 100% pre-testing for absolute quality assurance
- Consistent even winding tension assures freedom from microphonics
- A single capacitor = a singular sound; no time smear from multiple sections
- Blue striped lead to indicate lead connected to foil inner edge. (In a series connection the blue lead should be closer to the speaker; in parallel the blue lead should be closer to ground.)
- \*Coupling Caps, designed for use in electronics, but suitable for speakers. (Red lead should be closer to speaker in series connection.)



Value	WVDC	Dimensions (D x L)(Inches)	Price Each
0.01 $\mu\text{f}^*$	1600V	0.39 x 1.17	\$8.55
0.1 $\mu\text{f}^*$	600V	0.50 x 1.75	\$10.05
0.47 $\mu\text{f}^*$	600V	0.80 x 2.50	\$18.95
4.7 $\mu\text{f}^*$	100V	0.95 x 2.75	\$25.60
1.0 $\mu\text{f}$	100V	0.55 x 2.00	\$15.00
1.5 $\mu\text{f}$	100V	0.70 x 2.00	\$18.30
2.0 $\mu\text{f}$	100V	0.70 x 2.25	\$20.75
2.2 $\mu\text{f}$	100V	0.75 x 2.25	\$21.30
2.7 $\mu\text{f}$	100V	0.80 x 2.25	\$21.75
3.0 $\mu\text{f}$	100V	0.75 x 2.88	\$22.30
3.3 $\mu\text{f}$	100V	0.82 x 2.88	\$22.70
4.0 $\mu\text{f}$	100V	0.85 x 2.88	\$26.00
4.7 $\mu\text{f}$	100V	0.95 x 2.88	\$27.20
5.0 $\mu\text{f}$	100V	0.95 x 2.88	\$28.00
6.0 $\mu\text{f}$	100V	0.94 x 2.88	\$31.20
7.0 $\mu\text{f}$	100V	1.05 x 3.25	\$34.30
8.0 $\mu\text{f}$	100V	1.10 x 3.25	\$37.35
9.0 $\mu\text{f}$	100V	1.20 x 3.25	\$40.65
10.0 $\mu\text{f}$	100V	1.35 x 3.25	\$43.85

## What the reviewers say...

“After auditioning a wide variety of caps, I find these film-and-foil capacitors to be the most musical performers—and by a large margin. The MusiCap specializes in textural liquidity (lack of grain) and delicacy of treble nuances.”

*Dick Olsner, Reviewer and Designer for Samadhi Acoustics, November 1996 white paper*

“...the extra ambiance, combined with a very clean treble delivery that seemed far less prone to ringing or sibilance than the other types does make them really quite special.”

*Domini Baker, HI-FI WORLD SUPPLEMENT, August 1996*

“If you want see-thru, high definition, detail and listenability, try the MusiCaps.”

*Joe Roberts, Editor, SOUND PRACTICES, Issue 6 1994*

“The improved signal transmission of the Hovland foil capacitors elevated the [Ariel] speakers to a new level of naturalness, clarity, and immediacy.”

*Lynn Olson, POSITIVE FEEDBACK, Vol. 5, No. 4*

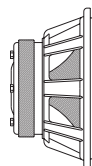

MADISOUND SPEAKER COMPONENTS, INC.

8608 UNIVERSITY GREEN

P.O. BOX 44283

MADISON, WI 53744-4283 U.S.A.

TEL: 608-831-3433 FAX: 608-831-3771

e-mail: info@madisound.com

Web Page: <http://www.madisound.com>

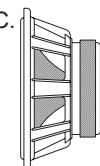

# Bennic Capacitors (Electrolytic & Polypropylene)

## Metallized Polypropylene Capacitors, XPP Series, 160VAC/250VDC

Tolerance Range : +/- 5%  
 Dissipation Factor : Maximum 0.07% @ 1KHz  
 Operating Temp. : -40°C to +105°C  
 Capacitance Drift : Maximum 2% cycled through the operating temp. range  
 Insulating Resist. : Min. 10,000 Mega-Ohm X rated caps (mfd) at 25°C  
 Life Test : 150% of rated working voltage at 105°C for 1,000 hours  
 Lead Length : 40 mm minimum  
 Color : Black tape, Yellow body, White wording

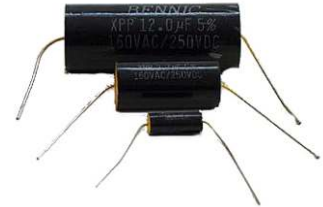

Value mfd	D / L mm	Price Each	Value mfd	D / L mm	Price Each
0.1	6 / 16	\$0.30	4.7	19 / 36	\$2.15
0.47	8 / 24	\$0.50	5.6	17 / 45	\$2.40
1.0	10 / 31	\$0.65	6.8	18 / 45	\$2.50
1.5	12 / 31	\$0.80	8.2	20 / 46	\$3.40
2.2	14 / 31	\$1.15	10	23 / 46	\$3.75
2.7	15 / 31	\$1.30	12	22 / 55	\$4.05
3.3	16 / 35	\$1.60	16	24 / 55	\$5.25
3.9	16 / 35	\$1.85			

## BI-POLAR ELECTROLYTIC CAPACITORS, 100WV

Tolerance Range : +/- 10% @ 1KHz  
 Leakage : Maximum 0.04 CV + 3 µA After Charge 5 Minutes  
 Temp. Range : -40°C to +85°C  
 Surge Volt : 125 for 100WV  
 Lead Length : 40 mm minimum  
 Max D.F. : Maximum 5% @1KHz Values 12mfd to 150mfd  
 Maximum 10% @1KHz Values 165mfd to 1000mfd  
 Color : Blue



Value mfd	D / L mm	Price Each	Value mfd	D / L mm	Price Each
12	12 / 31	\$0.75	140	22 / 45	\$2.95
18	12 / 31	\$0.85	150	22 / 45	\$3.10
22	12 / 31	\$0.95	165	16 / 42	\$2.90
31	16 / 34	\$1.10	180	16 / 42	\$3.00
40	16 / 34	\$1.25	200	16 / 42	\$3.05
50	16 / 34	\$1.45	250	18 / 42	\$3.75
65	16 / 34	\$1.55	280	18 / 45	\$4.20
80	16 / 42	\$1.80	330	22 / 45	\$4.50
100	18 / 42	\$2.00	500	25 / 51	\$6.15
125	22 / 45	\$2.50	1000	25 / 60	\$9.00

## Carli Metallized Polyester Film Capacitors (Mylar)

Carli Metallized Polyester Film Capacitors (Mylar)				
Value µfd	Description	Ø mm	L mm	Price Each
1.0	Mylar 10% 150 volt	8	19	\$0.60
2.7	Mylar 10% 150 volt	10	31	1.00
3.3	Mylar 10% 150 volt	11	25	1.05
3.9	Mylar 10% 150 volt	12	31	1.15
4.7	Mylar 10% 150 volt	13	31	1.25
6.0	Mylar 10% 150 volt	14	31	1.50
6.8	Mylar 10% 150 volt	14	31	1.70
8.0	Mylar 10% 150 volt	16	31	1.95
10.0	Mylar 10% 150 volt	16	31	2.30

Carli Metallized Polyester Film Capacitors (Mylar)				
Value µfd	Description	Ø mm	L mm	Price Each
12.0	Mylar 10% 150 volt	20	31	2.75
15.0	Mylar 10% 150 volt	23	31	3.40
20.0	Mylar 10% 150 volt	21	46	5.00

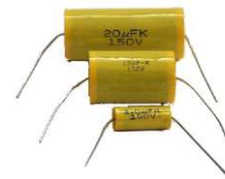



# General Electric Polypropylene Capacitors

**Madisound** has acquired a large lot of Metallized Polypropylene Capacitors manufactured by General Electric. We are offering these capacitors to you at a fraction of the normal selling price. The voltages of these capacitors make them suitable for use in speakers or electronics. Very low series inductance and series resistance minimize power dissipation and provide an extremely reliable product with unsurpassed performance characteristics. They also sound great! These caps are wonderful on Fostex super tweeters.

**GE 40L Series Metallized Polypropylene Capacitor;** axial; 10%; 50 mm long tinned copper leads; white fire retardant tape with polyurethane potting compound; oval shape; dissipation factor 0.1% maximum

Value $\mu$ fd	Vdc	Vac	ESR (m $\Omega$ )	Dim. H mm	Dim. W mm	Dim. L mm	\$ 1-19	\$ 20-99	\$ 100+
5.0	400	250	7	16	22	43	0.75	0.65	0.50
10.0	400	250	7	20	26	55	1.40	1.15	0.90
0.68	600	330	.55	12	18	31	0.30	0.20	0.15

40L Series



41/42L Series



**GE 41L Series Metallized Polypropylene Capacitor;** axial; 5%; 40mm long tinned copper leads, yellow polyester wrapping with epoxy resin end fill; dissipation factor  $5 \times 10^{-4}$  @ 1KHz and 25°C; low ESR (series resistance)

Value $\mu$ fd	Vdc	Vac	ESR (m $\Omega$ )	Dim. $\emptyset$ mm	Dim. L mm	\$ 1-19	\$ 20-99	\$ 100+
6.8	400	250	2.1	25	42	1.50	1.20	0.95

**GE 42L Series Metallized Polypropylene Capacitor;** axial; 5%; 40mm long tinned copper leads; yellow polyester wrapping with epoxy resin end fill; dissipation factor  $5 \times 10^{-4}$  @ 1KHz and 25°C; low ESR (series resistance)

Value $\mu$ fd	Vdc	Vac	ESR (m $\Omega$ )	Dim. $\emptyset$ mm	Dim. L mm	\$ 1-19	\$ 20-99	\$ 100+
0.15	850	450	9.5	10	31	0.35	0.20	0.15
0.33	850	450	4.8	14.5	31	0.40	0.30	0.20
0.47	850	450	3.5	17	31	0.50	0.35	0.25
0.68	1200	500	2.7	27.5	42	0.65	0.50	0.40

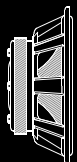

**Madisound Speaker Components**  
P.O. Box 44283  
Madison, WI 53744-4283  
USA

Tel: 608-831-3433  
Fax: 608-831-3771  
e-mail: [info@madisound.com](mailto:info@madisound.com)  
<http://www.madisound.com>



## Supreme Silver/Gold Capacitor

The metallisation of the capacitor foil for the MCap Supreme Silver/Gold consists of 99.99% pure silver, to which 1% high purity gold is added. Gold alters the crystalline structure of the silver maximizes its electrical conductivity. This capacitor uses a special inductance-free winding. Two capacitor windings are interleaved (in series), so that their inductances effectively cancel. For example, two 2µf windings are used to make one 1µf capacitor. When embedded in complete silence, instruments and voices can develop their absolute clearness and power. Tolerance ±2%.



µf	VDC	D*L/mm	Price	mf	VDC	D*L/mm	Price	mf	VDC	D*L/mm	Price
0.010	1200	12*27	\$29.80	0.68	1200	25*38	\$46.30	4.70	1200	40*69	\$114.05
0.022	1200	12*27	\$29.80	1.00	1200	30*39	\$54.95	5.60	1200	45*69	\$124.25
0.047	1200	12*27	\$29.80	2.20	1200	40*53	\$70.85	6.80	1200	45*69	\$139.55
0.10	1200	16*34	\$32.90	2.70	1200	40*53	\$79.45	8.20	1200	45*69	\$157.65
0.22	1200	18*37	\$37.35	3.30	1200	40*53	\$88.40	10.0	1200	45*69	\$191.15
0.47	1200	20*37	\$42.35	3.90	1200	40*53	\$99.35				

## Supreme Silver/Oil Capacitor

This product is an oil impregnated, silver metallized polypropylene dielectric capacitor. This capacitor uses a special inductance-free winding. Two capacitor windings are interleaved (in series), so that their inductances effectively cancel. For example, two 2µf windings are used to make one 1µf capacitor. High purity silver (99.99%) is used for the capacitor coating. A special oil has been chosen to contribute to an even fuller and smoother tonal richness and diversity. Mundorf Supreme Silver/Oil capacitors are arguably the best sounding audiophile capacitors available. Tolerance ±2%.



µf	VDC	D*L/mm	Price	µf	VDC	D*L/mm	Price	µf	VDC	D*L/mm	Price
0.01	1200	12*27	\$20.20	0.68	1200	25*38	\$28.25	3.90	1200	40*53	\$55.40
0.10	1200	16*34	\$20.40	0.82	1200	30*39	\$30.75	4.70	1200	40*69	\$60.20
0.15	1200	16*34	\$20.90	1.00	1200	30*39	\$33.30	5.60	1200	45*69	\$66.65
0.22	1200	18*37	\$21.70	1.50	1200	35*39	\$37.90	6.80	1200	45*69	\$74.65
0.33	1200	18*37	\$22.95	2.20	1200	40*53	\$43.90	8.20	1200	50*68	\$84.65
0.47	1200	20*37	\$24.70	2.70	1200	40*53	\$46.45	10.0	1200	45*105	\$101.40
0.56	1200	25*38	\$26.40	3.30	1200	40*53	\$50.75				

## Supreme Polypropylene Capacitor

The Supreme capacitor uses the same special induction-free winding technology as the Silver/Oil capacitor. This capacitor is a metallized polypropylene film, with exceptional low loss characteristics. The Supreme is equally suited to electronics as it is for high-end loudspeakers. No matter where you use the MCap Supreme - as a coupling capacitor in your CD player or amplifier, or in the crossover of your speakers - you always get the same surprising and impressive performance. Whether your upgrading a premium system of a price conscious configuration, Supreme will deliver a significant enhancement. Tolerance ±2%



µf	VDC	D*L/mm	Price	µf	VDC	D*L/mm	Price	µf	VDC	D*L/mm	Price
0.10	1200	17*36	\$10.00	1.00	800	20*40	\$17.70	5.60	800	36*56	\$33.80
0.15	1200	19*38	\$10.95	1.50	800	25*55	\$19.35	6.80	800	41*57	\$34.75
0.22	1200	20*38	\$11.95	1.80	800	25*55	\$20.90	8.20	800	36*106	\$41.20
0.33	1200	25*52	\$13.85	2.20	800	25*55	\$21.90	10.0	800	36*106	\$46.65
0.47	800	20*39	\$14.80	2.70	800	30*56	\$22.85	15.0	800	41*102	\$59.60
0.56	800	20*39	\$15.80	3.30	800	30*56	\$25.10	22.0	800	50*106	\$82.15
0.68	800	20*39	\$16.00	3.90	800	30*56	\$27.35				
0.82	800	20*40	\$16.75	4.70	800	36*56	\$29.60				



**M-Connect 105 Kit**  
With 6mm Pure Copper Posts  
•Price Each Kit \$74.80  
105mm Round x 8mm



**M-Connect 122 Bi-Wire Kit**  
With 6mm Pure Copper Posts  
•Price Each Kit \$144.95  
Strap not included.  
122mm x 96mm x 8mm



**M-Connect 130 Kit**  
Available with Pure Copper or Brass 8mm Posts.  
•Copper Posts Kit \$99.75 each  
•Brass Posts Kit \$66.45 each  
130mm round x 8mm



**M-Connect 150 Bi-wire Kit**  
Available with Pure Copper or Brass 8mm Binding Posts  
•Copper Posts Kits \$190.30 each  
•Brass Posts Kits \$123.70 each  
Shorting strap not included.  
150mm x 124mm x 8mm



**M-Connect 6mm Pure Copper Posts**  
Red or Black  
•\$32.40 each  
Includes nuts



**M-Connect 8mm Posts**  
Red or Black, with nuts  
•Copper Post Each \$43.05  
•Brass Post Each \$25.55

**Retail Price List • Effective September 1, 2004**
**RCA TYPE CONNECTORS**
**ILLUSTRATIONS NOT TO SCALE**

**WBT-0110Ag nextgen™ Signature**

Retail

\$49.00

**WBT-0110Ag-KIT**

4 Plugs, 12 ferrules, WBT™ solder, Torx™ key, boxed

\$199.00

Pure Fine Silver contacts plated with a thin layer of Platinum. The body is constructed of Ultramid®, while the negative contact uses Dyneon™. The Barrel is comprised of Al/Mg alloy for improved rejection of EMC. A characteristic impedance of 75 Ω makes this a perfect match for digital audio and video. The maximum size conductor that can be used is 1.5mm<sup>2</sup> / 16-17 AWG. Maximum diameter of cable with dielectric is 9mm<sup>2</sup> / 0.354 inches<sup>2</sup>.

**WBT-0110Cu nextgen™ Topline**

Retail

\$28.00

**WBT-0110Cu-KIT**

4 Plugs, 12 ferrules, WBT™ solder, Torx™ key, boxed

\$115.00

As above with contacts manufactured from pure Oxygen Free Copper and plated with a thin layer of 24k Gold to provide protection from oxidation.

**WBT-0101 Topline**

Retail

\$32.00

**WBT-0101-KIT**

4 Plugs, 12 ferrules, WBT™ solder, Torx™ key, boxed

\$134.00

Ultra fine machining grants smooth operation of unit. Unique plating process with final plating of 24k Gold. Patented WBT™ barrel provides both adjustment and locking function. The barrel is finished in polished ruthenium. A slotted center pin allows a perfect fit. Teflon™ insulation. Strain relief captured with Torx™ T6 size set screw. Maximum cable diameter allowed is 9mm<sup>2</sup> / 0.354 inches<sup>2</sup>.

**WBT-0108 Topline**

Retail

\$35.00

**WBT-0108-KIT**

4 Plugs, 12 ferrules, WBT™ solder, Torx™ key, boxed

\$150.00

Crimp version of the WBT-0101. Signal (maximum 16 AWG) and ground (maximum 14 AWG) wires first prepared with a crimp sleeve then fastened to the connector with Torx™ T6 size set screws. The greatest cable diameter that can be accommodated is 9mm<sup>2</sup> / 0.354 inches<sup>2</sup>.

**WBT-0150 Topline**

Retail

\$35.00

**WBT-0150-KIT**

2 Plugs, WBT™ solder, Torx™ key, boxed

\$76.00

This connector is an oversized version of the WBT-0101 with a similar construction and features. Accommodates a cable diameter between 9.1-11.3 mm<sup>2</sup> / 0.358-0.445 inches<sup>2</sup>.



**RCA TYPE CONNECTORS**

ILLUSTRATIONS NOT TO SCALE



**WBT-0144 Midline**

Retail

\$17.00

**WBT-0144-KIT**

4 Plugs, 12 ferrules, WBT™ solder, Torx™ key, boxed

\$74.00

As a midline offering of the WBT-0101, this connector has all the same style and finesse. Differences include a barrel finished in matte black, lower yet efficient machining tolerances and lesser percentage Oxygen Free Copper alloy stock. The largest diameter cable that can be accepted by this RCA type connector is 9mm<sup>2</sup> / 0.354 inches<sup>2</sup>.



**WBT-0147 Midline**

Retail

\$17.00

**WBT-0147-KIT**

4 Plugs, 8 ferrules, WBT™ solder, Torx™ key, boxed

\$74.00

While being a compact version of the WBT-0144, shorter and thinner, this connector works well with smaller diameter cables. The appearance is more aesthetically pleasing. With a maximum cable diameter of 7.8mm<sup>2</sup> / 0.307 inches<sup>2</sup>, this is WBT's smallest RCA type plug.



**At a Glance RCA Plug Comparison Chart**

RCA PLUGS	Final body finish	External Plating, layers & thickness	Metallurgic properties of signal contact area	Properties of connector body	Termination			Available marking colors for Multichannel identification								
					Solder	Crimp	PCB Mount	Red	Orange	Yellow	Green	Blue	Violet	White	Grey	Black
WBT0101	double 24k Gold with Polished Ruthenium Barrel	Nickel free 5 Layers Cu 11µm duplex Pd 4µm Au 0.3µm duplex	68% Oxygen free Copper alloy with Teflon™ insulation	68% Oxygen free Copper alloy 2/100 mm Machining Tolerance	●			●	●	●	●	●	○		●	
WBT0108	double 24k Gold with Polished Ruthenium Barrel	Nickel free 5 Layers Cu 11µm duplex Pd 4µm Au 0.3µm duplex	68% Oxygen free Copper alloy with Teflon™ insulation	68% Oxygen free Copper alloy 2/100 mm Machining Tolerance		●		●	●	●	●	●	○		●	
WBT0110Ag	Color coded Ultramid™	1 Layer Pt 0.4 µm	100% Fine Silver	Main body of Ultramid™ Modular insert of Dyneon™	●			●	●	●	●	●	●	○	○	●
	Ceramic coated Al/Mg alloy barrel															
WBT0110Cu	Color coded Ultramid™	1 Layer Au 0.5 µm	99.996% Copper	Main body of Ultramid™ Modular insert of Dyneon™	●			●	●	●	●	●	●	○	○	●
	Ceramic coated Al/Mg alloy barrel															
WBT0144	24k Gold plating with Matte black barrel	3 Layers Cu 1.5 µm Ni 8.0 µm Au 0.2 µm	55% Oxygen free Copper alloy with Teflon™ insulation	55% Oxygen free Copper alloy 5/100 mm Machining Tolerance	●			●	●	●	●	●	○		●	
WBT0147	24k Gold plating with Matte black barrel	3 Layers Cu 1.5 µm Ni 8.0 µm Au 0.2 µm	55% Oxygen free Copper alloy with Teflon™ insulation	55% Oxygen free Copper alloy 5/100 mm Machining Tolerance	●			●	●	●	●	●	○		●	
WBT0150	double 24k Gold with Polished Ruthenium Barrel	Nickel free 5 Layers Cu 11µm duplex Pd 4µm Au 0.3µm duplex	68% Oxygen free Copper alloy with Teflon™ insulation	68% Oxygen free Copper alloy 2/100 mm Machining Tolerance	●			●	●	●	●	●	○		●	



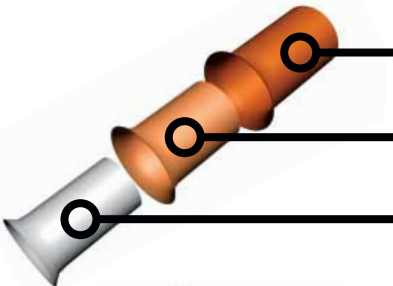

**STRAIN RELIEF FERRULES**

	Works with WBT part #	Cable Size	Retail
 <p><b>WBT-0580</b></p>	0101, 0108, 0144	7.2 to 8.1 mm	\$0.40
 <p><b>WBT-0590</b></p>	0101, 0108, 0144, 0147	5.5 to 7.4 mm	\$0.40
 <p><b>WBT-0595</b></p>	0101, 0108, 0144, 0147	4.5 to 5.9 mm	\$0.40

**Note:** WBT-0590 will nest inside WBT-0580, and WBT-0595 will nest inside WBT-0590, meaning you can use more than one sleeve at the same time.

**Note:** All RCA type kits are packaged with a complete set of ferrules.

**RCA TYPE CONNECTOR TIGHTENING INSTRUCTIONS**

**Step 1**  
Loosen barrel of the male connector.

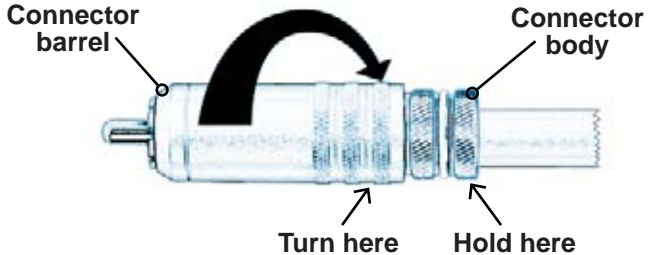

Connector barrel

Connector body

Turn here

Hold here

**Step 2**  
Insert the connector into the socket.



RCA type socket

Connector assembly

**Step 3**  
Hold the connector body and tighten the barrel.

**WARNING:** To prevent damage to cable and/or socket, turn barrel only, do not allow connector body to turn!  
Do not over tighten!

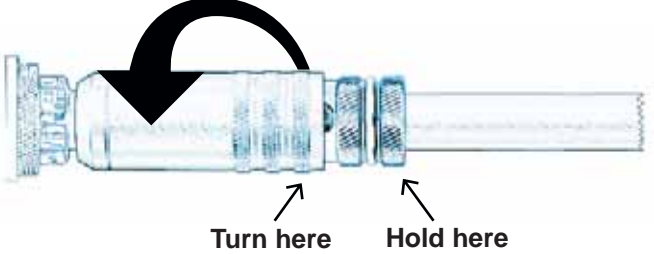

Turn here

Hold here

**REMEMBER TO REVERSE ABOVE STEPS WHEN REMOVING THE CONNECTORS. Failure to properly unlock the connector may result in equipment damage!**

**ASSERTIONS**

**HISTORY** - In 1985, WBT™ developed the first RCA type plug machined from a single piece of metal. This plug featured an adjustable locking mechanism, the first of its kind. Since 1985, WBT has continued to refine the art and science of connection. From a single idea has developed an impressive array of audio connectors and accessories. Today, WBT is known worldwide for the best connectors in the industry.

**SOLDERING** - Soldered connections possess inherent disadvantages: the use of high temperatures, multi material contact junctions and low tolerance to mechanical stresses. The transition medium between cable and connector is a mixture of lead, tin and other metals. This process forms a multi material, high resistance connection. Standard solders generally use flux agents containing halogens that attack cable strands and the connector.

While melting solder, it is often necessary to create such high temperatures that the chemical composition of dielectrics is changed. Halogens can be released from the dielectrics causing soldered contacts to remain chemically active. This results in soldered contacts that are brittle from crystallization. Furthermore, there is a high risk of cold solder joints on large solder jobs, such as loudspeaker cables, because it is difficult to properly heat the material masses.

To prevent the unwanted conditions associated with soldering, WBT's crimping method is the preferred technique. If a soldered connection must be made, then the use of WBT solder is preferable. Using WBT 4% silver solder will allow the full sonic potential of WBT's solder type connectors. WBT solder uses halogen free flux and has an extremely low melting temperature to help prevent the release of halogens from dielectrics. The silver creates a more conductive solder, thus generating the best solder connection available.

**CRIMPING** - Crimping is a connection technique which has been employed for many years in a variety of technical fields. In terms of contact quality, crimping is superior to soldering and far easier to accomplish. This is provided that the connectors are of suitable design. WBT has created a wide range of crimp connectors and was the first company to apply this technique in the audio field.

**TECHNIQUE** - Aside from the connectors, the only items required are WBT crimping pliers and WBT crimp sleeves. The sleeves are made of two different materials; highly conductive electrolyte Copper and pure fine Silver (Copper sleeves are plated with 24k Gold and Silver sleeves are plated with Platinum). Under the pressure of the pliers, the surface layers of the materials flow into one another and give the appearance of a single strand of wire. Intermediate air is also eliminated for corrosion/tarnish resistance. This connection piece is then fitted to a connector and attached using a set screw.

**ADVANTAGE** - Crimping produces a physically optimum contact point with low transition resistance, ensuring pure signal transmission. Crimping is a cold welding technique for which a heat supply is not necessary. The technique is easy to apply and easy to fit and refit WBT connectors.

**RCA TYPE SOCKETS**

ILLUSTRATIONS NOT TO SCALE

**WBT-0210Ag nextgen™ Signature**

Retail

\$42.00

**WBT-0210Ag-KIT**

2 Sockets, WBT™ solder, boxed

\$87.00

The Highest quality socket available on the market, with Pure Fine Silver contacts for both positive and negative connections. A single layer of Platinum plating protects each contact against tarnish. The positive contact utilizes WBT's famous dual prism spring loaded feature to assure a secure connection. Teflon™ dielectric surrounds the positive contact. The main body is comprised of 30% glass reinforced Ultramid® with the ground (negative) contact embedded within the connector. The complete unit includes insulation washers to accommodate a panel thickness from 0.1-4.2mm.

**WBT-0210Cu nextgen™ Topline**

Retail

\$24.00

**WBT-0210Cu-KIT**

2 Sockets, WBT™ solder, boxed

\$51.00

As above with both contacts, positive and negative, manufactured from pure Oxygen Free Copper and plated with a thin layer of 24k Gold to provide protection from oxidation.

**WBT-0201 Topline**

Retail

\$30.00

**WBT-0201-KIT**

2 Sockets, WBT™ solder, boxed

\$62.00

This RCA type socket is an old favorite among many audio enthusiasts. Featuring 99.996% high copper content, the dual prism spring loaded contact, WBT's 24k gold supra-plating process and Teflon™ dielectric. Socket tightens from the outside of a chassis using the included mounting nut. The complete unit includes insulation washers to accommodate a panel thickness from 0.1-4.2mm.

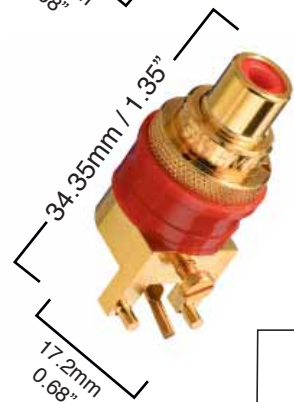
**PCB MOUNT**

Retail

**WBT-0234 Topline**

\$35.00

Right angle, printed circuit board version of the WBT-0201 with a screw to secure the connection to a printed circuit board. The ground contact is made through the securing screw to the PCB and two additional solder points. The signal, or positive contact, has one solder contact point.

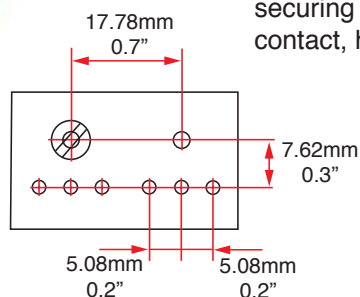



**RCA TYPE SOCKETS**

ILLUSTRATIONS NOT TO SCALE

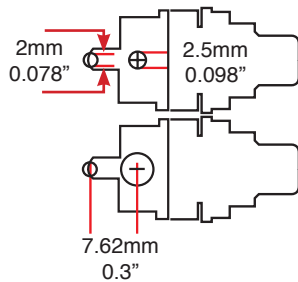
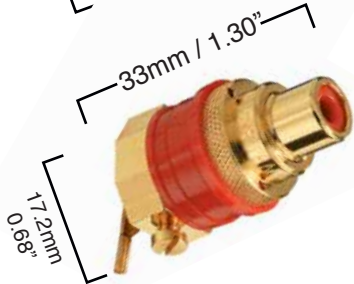
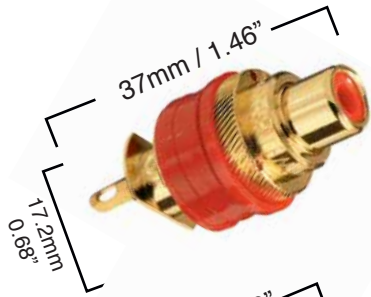

**WBT-0244 Midline**

Retail

\$26.00

The WBT-0244 is a midline version of the WBT-0201 which differs only in the copper content of the main body and the machining tolerances.

**PCB MOUNT**

**WBT-0274 Midline**

Retail

\$26.00

A midline offering of the WBT-0234, this connector provides a single ground and signal or positive mounting position. The socket body is machined of a lower percentage copper alloy, but the positive contact is made of 99.996% pure copper as with all WBT sockets.

**All WBT RCA Type Sockets require the following mounting hole dimensions**

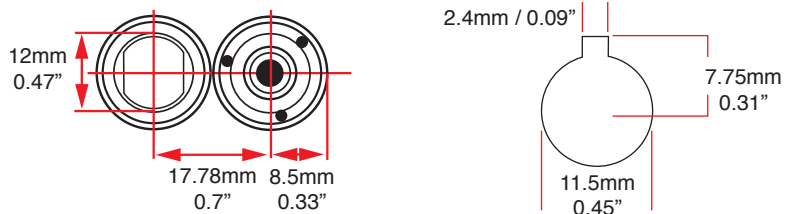

**At a Glance RCA Socket Comparison Chart**

RCA SOCKETS	Final body finish	External Plating, layers & thickness	Maximum Cable diameter size accepted	Metallurgic properties of signal contact area	Properties of connector body	Termination			Available marking colors for multichannel identification								
						Solder	Crimp	PCB Mount	Red	Orange	Yellow	Green	Blue	Violet	White	Grey	Black
WBT0201	24k Gold	Nickel free 2 layers Bronze 5µm Au 0.3µm	1.5mm <sup>2</sup> 16 AWG	99.996% Oxygen free copper with 0.3µm 24k Gold plating Teflon™ Insulated	68% Oxygen free Copper alloy 0.1-4.2mm mounting panel thickness	●			●		●				○		
WBT0210Ag	Grey Ultramid	Non Metal	1.5mm <sup>2</sup> 16 AWG	100% Fine Silver with 0.4µm Platinum plating Teflon™ Insulated	Main body of Ultramid™ 0.1-4.2mm mounting panel thickness	●			●	●	●	●	●	●	○	○	●
WBT0210Cu	Grey Ultramid	Non Metal	1.5mm <sup>2</sup> 16 AWG	99.996% Oxygen free copper with 0.5µm 24k Gold plating Teflon™ Insulated	Main body of Ultramid™ 0.1-4.2mm mounting panel thickness	●			●	●	●	●	●	●	○	○	●
WBT0234	24k Gold	Nickel free 5 layers Cu 11µm duplex Pd 4µm Au 0.3µm duplex	Printed Circuit board mounting (right angle)	99.996% Oxygen free copper with 0.3µm 24k Gold plating Teflon™ Insulated	68% Oxygen free Copper alloy 0.1-4.2mm mounting panel thickness	●		●	●		●				○		
WBT0244	24k Gold	3 layers Cu 1.5µm Ni 8.0µm Au 0.2µm	2.5mm <sup>2</sup> 14AWG	99.996% Oxygen free copper with 0.3µm 24k Gold plating Teflon™ Insulated	55% Oxygen free Copper alloy 0.1-4.2mm mounting panel thickness	●			●		●				○		
WBT0274	24k Gold	3 Layers Cu 1.5 µm Ni 8.0 µm Au 0.2 µm	Printed Circuit board mounting (right angle)	99.996% Oxygen free copper with 0.3µm 24k Gold plating Teflon™ Insulated	55% Oxygen free Copper alloy 0.1-4.2mm mounting panel thickness	●		●	●		●				○		



## SPEAKER CONNECTORS

ILLUSTRATIONS NOT TO SCALE

### WBT-0600 Topline

Retail

\$35.00

### WBT-0600-KIT

4 Plugs, 1 Torx™ key, boxed

\$144.00

Top quality banana plug with robust design and sleeve with polished ruthenium finish. Offering high contact pressure due to an expanding inner spike ensures a solid mechanical fit. Termination fitted with two Torx™ screws size T6 for secure crimp connection as well as cable strain relief. Easy fit for wire size up to 10mm<sup>2</sup> / 8 AWG.

### WBT-0644 Midline

Retail

\$18.00

### WBT-0644-KIT

4 Plugs, 1 Torx™ key, boxed

\$76.00

A midline offering of the WBT-0600, this banana plug has the same style and elegance. Differences include a barrel finished in matte black, lower yet efficient machining tolerances and lesser grade Oxygen Free Copper alloy stock. The largest diameter cable accepted for termination is 10mm<sup>2</sup> / 8 AWG.

### CE COMPLIANT

### STACKABLE

Retail

### WBT-0645 Midline - Safety Line

\$20.00

### WBT-0645-KIT

4 Plugs, 1 Torx™ key, boxed

\$84.00

An Innovative banana plug approved worldwide as a loudspeaker cable connector due to the safety pin design. It is fully insulated using Makrolon®. A secure connection is possible through an expanding inner spike which provides high clamping power. While using only one hand, cables can be connected in tight spaces with just thumb and forefinger. Extremely compact, sloping angle is easy on cable and equipment. The WBT-0645 is stackable for bi-wiring. Two Torx™ screws for extra tight pressure connection and additional cable strain relief. Connector can accommodate a cable diameter size of 10mm<sup>2</sup> / 8 AWG.

### CE COMPLIANT

Retail

### WBT-0660Cu Topline

\$20.00

### WBT-0660Cu-KIT

4 Plugs, 1 Torx™ key, boxed

\$84.00

High current spade lug with elastomeric shock absorber for progressive contact pressure eliminating structure born and air born noise as well as magnetostriction. Fully insulated body is safe to use and conforms to international safety standards. 1/4 inch / 6.4mm sandwich spade connector. Pure Oxygen Free Copper contact is direct Gold plated to protect against oxidation. Easy fit for wire sizes up to 10mm<sup>2</sup> / 8AWG.

### CE COMPLIANT

Retail

### WBT-0680Cu Topline

\$20.00

### WBT-0680Cu-KIT

4 Plugs, 1 Torx™ key, boxed

\$84.00

Same as the WBT-0660Cu but in a larger size of 5/16 inch / 8.1mm sandwich spade connector. Easy fit for wire sizes up to 10mm<sup>2</sup> / 8AWG.

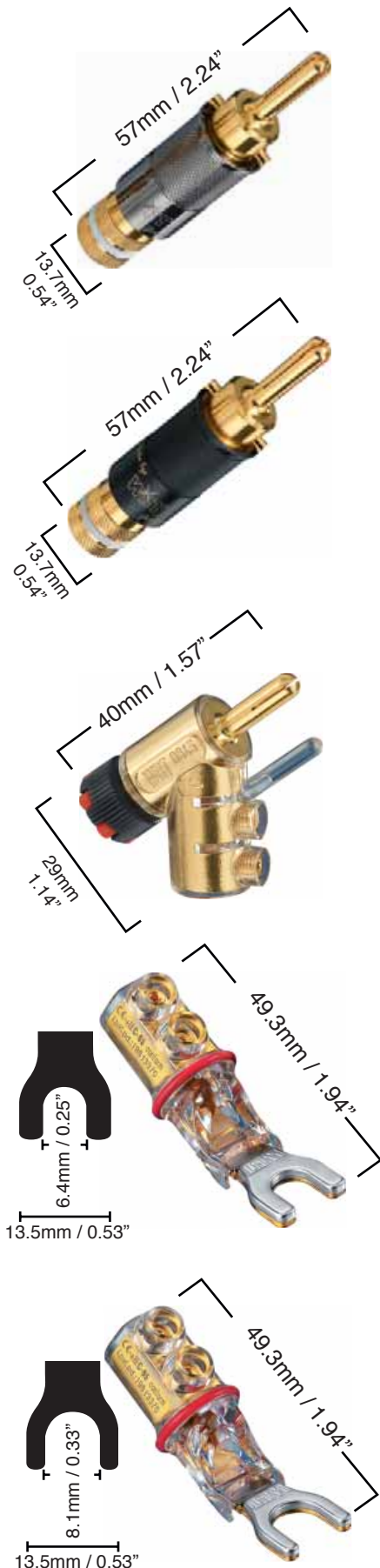



Retail Price List • Effective September 1, 2004

**SPEAKER CONNECTORS**

ILLUSTRATIONS NOT TO SCALE

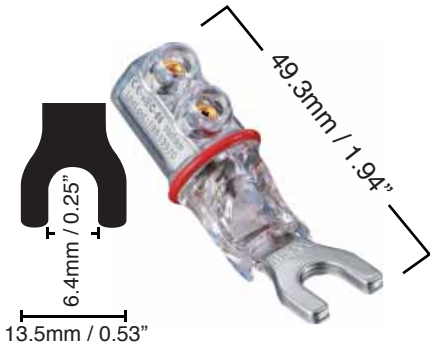

**CE COMPLIANT**

**WBT-0660Ag Signature**

Retail

\$40.00

**WBT-0660Ag-KIT**

4 Plugs, 1 Torx™ key, boxed

\$164.00

1/4 inch / 6.4mm sandwich spade connector. Pure Fine Silver contact is direct Platinum plated to protect against tarnish. High current spade lug with elastomeric shock absorber for progressive contact pressure eliminating structure born and air born noise as well as magnetostriction. Fully insulated body is safe to use and conforms to international safety standards. Easy fit for wire sizes up to 10mm<sup>2</sup> / 8AWG.

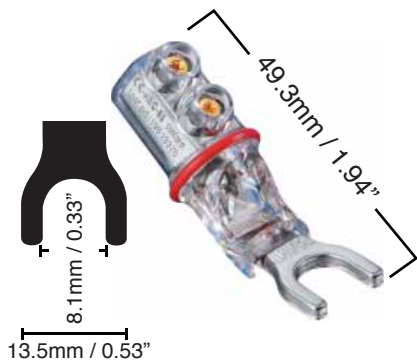

**CE COMPLIANT**

**WBT-0680Ag Signature**

Retail

\$40.00

**WBT-0680Ag-KIT**

4 Plugs, 1 Torx™ key, boxed

\$164.00

Same as the WBT-0660Ag but in a larger size of 5/16 inch / 8.1mm sandwich spade connector. Pure Fine Silver contact is direct Platinum plated to protect contact metal from tarnish. Easy fit for wire sizes up to 10mm<sup>2</sup> / 8AWG.

**At a Glance Speaker Connector Comparison Chart**

SPEAKER CONNECTORS	Final body finish	External Plating, layers & thickness	Metallurgic properties of signal contact area	Properties of connector body	Termination				Available marking colors for Multichannel identification								
					Solder	Crimp	PCB Mount	Red	Orange	Yellow	Green	Blue	Violet	White	Grey	Black	
WBT0600	24k Gold plated	Nickel free 5 layers Cu 11µm duplex Pd 4µm Au 0.3µm duplex	68% Oxygen free Copper alloy	68% Oxygen free Copper alloy	●	●		●							○		●
WBT0644	24k Gold plated	3 layers Cu 1.5µm Ni 8.0µm Au 0.2µm	52% Oxygen free Copper alloy	52% Oxygen free Copper alloy	●	●		●							○		●
WBT0645	Makrolon™ over 24k Gold plating	3 layers Cu 1.5µm Ni 8.0µm Au 0.2µm	55% Oxygen free Copper alloy	55% Oxygen free copper alloy CE and IEC 65 Compliant		●		●							○		●
WBT0660Cu	Makrolon™ over 24k Gold plating	24k Gold plating	99.996% Copper	3 part: brass, cage, pure CU contact, Stainless steel former CE and IEC 65 Compliant		●		●							○		●
WBT0680Cu	Makrolon™ over 24k Gold plating	24k Gold plating	99.996% Copper	3 part: brass, cage, pure CU contact, Stainless steel former CE and IEC 65 Compliant		●		●							○		●
WBT0660Ag	Makrolon™ over Platinum plating	Platinum plating	Pure fine silver	3 part: brass, cage, pure Ag contact, Stainless steel former CE and IEC 65 Compliant		●		●							○		●
WBT0680Ag	Makrolon™ over Platinum plating	Platinum plating	Pure fine silver	3 part: brass, cage, pure Ag contact, Stainless steel former CE and IEC 65 Compliant		●		●							○		●



**Retail Price List • Effective September 1, 2004**
**BINDING POSTS - INCLUDES INSULATING WASHER AND SET NUT**
**ILLUSTRATIONS NOT TO SCALE**

	Retail
<b>WBT-0702.01 Topline</b>	\$50.00
<b>WBT-0702.01-KIT</b> 2 posts, 1 Torx™ key, boxed	\$104.00
<p>With a 400 ampere continuous current capability, this is the perfect size binding post for demanding applications. A patented clamping mechanism makes it possible for high compression connection of spades and crimped wire ends up to 6mm<sup>2</sup> (10AWG). By means of a collet chucking device, any 4mm<sup>2</sup> banana plug can be securely clamped. Milled grooves on both sides of the compression plate provide high strength for connection of spades. <u>No tools</u> are required to provide a secure connection. Finger tightening is all that is required. This connector will not fit on a 3/4" or 19mm center to center spacing.</p>	
	Retail
<b>WBT-0702.03 Topline</b>	\$50.00
<b>WBT-0702.03-KIT</b> 2 posts, 1 Torx™ key, boxed	\$104.00
<p>Same as above (WBT-0702.01) but with a glass bead blasted finish in Velours Chormium. Looks like sand blasted Nickel.</p>	
	Retail
<b>WBT-0702.11 Signature</b>	\$60.00
<b>WBT-0702.11-KIT</b> 2 posts, 1 Torx™ key, boxed	\$124.00
<p>Comparable design as the WBT-0702.01 except it is manufactured using cold rolled 68% copper alloy. The connector is then plated with a single layer of 24k Gold to protect against oxidation. Finally, it is polished by hand to give an extreme finish.</p>	
	Retail
<b>WBT-0702.12 Signature</b>	\$60.00
<b>WBT-0702.12-KIT</b> 2 posts, 1 Torx™ key, boxed	\$124.00
<p>This binding post makes use of the same features as the WBT-0702.11 but with a highly polished Platinum finish.</p>	
	Retail
<b>WBT-0730.01 Topline</b>	\$30.00
<b>WBT-0730.01-KIT</b> 4 posts, 2 spacer blocks, 1 Torx™ key, boxed	\$124.00
<p>A 200 ampere continuous current rating makes this connector sufficient for most functions. Spade connectors are securely held with a patented high compression design. Wire with a diameter of 6mm<sup>2</sup> (10AWG) can also be accepted. Accepts 4 mm<sup>2</sup> banana plugs.</p>	



**BINDING POSTS - INCLUDES INSULATING WASHER AND SET NUT**

ILLUSTRATIONS NOT TO SCALE



**WBT-0730.11 Signature**

Retail

\$40.00

**WBT-0730.11-KIT**

2 posts, 1 Torx™ key, boxed

\$164.00

With the same manufacturing design as the WBT-0730.01 but created using cold rolled 68% copper alloy. The connector is then plated with a single layer of 24k Gold to protect against oxidation. Finally, it is polished by hand to give an extreme finish.

**WBT-0730.12 Signature**

Retail

\$40.00

**WBT-0730.12-KIT**

2 posts, 1 Torx™ key, boxed

\$164.00

Brother to the WBT-0730.11 but with a highly polished Platinum finish, some would say that the WBT-0730.11 and the WBT-0730.12 are fraternal twins.

**CE COMPLIANT**

Retail

**WBT-0735 Topline – Safety Line**

\$35.00

Utilizing a full insulation of Makrolon®, this binding post is part of WBT's Safety Line and is a CE and IEC compliant version of the WBT-0730.01.

**WBT-0763 Midline**

Retail

\$20.00

This post is a standard binding post for many high end amplifier and loudspeaker companies. This binding post features a patented rotating collar design that requires only finger tightening to securely fasten a spade. Able to handle 200 amperes of continuous current, this is just the right size binding post for nearly all applications. Set screw can be purchased separately.

**PCB MOUNT**

Retail

**WBT-0764 Midline**

\$23.00

Screw on printed circuit board version of the WBT-0763, can also accept ring terminal lugs.

**CE COMPLIANT**

Retail

**WBT-0765 Midline – Safety Line**

\$23.00

Using full insulation of Makrolon®, this binding post is part of WBT's Safety Line and is a CE and IEC compliant version of the WBT-0763

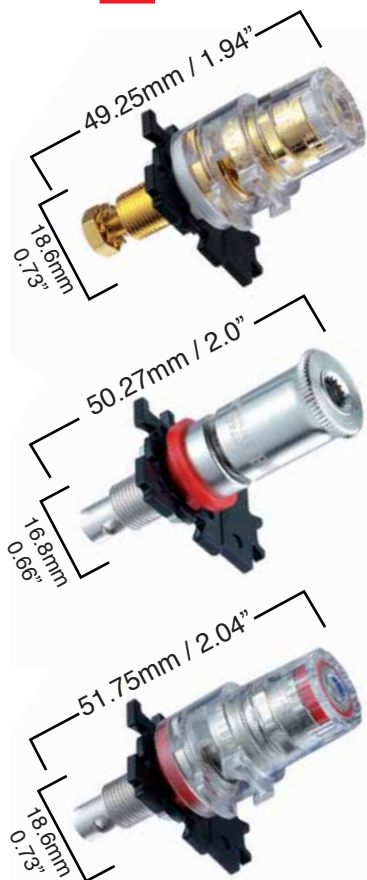

**Retail Price List • Effective September 1, 2004**
**BINDING POSTS - INCLUDES INSULATING WASHER AND SET NUT**
**ILLUSTRATIONS NOT TO SCALE**

CE COMPLIANT	PCB MOUNT	Retail
<b>WBT-0766 Midline – Safety Line</b>		\$26.00

With the same characteristics as the WBT-0765 except this post is designed for direct mounting on printed circuit board with included bolt and lock washer. Ring terminals attached to a jumper wire may also be used in lieu of a circuit board.

PCB MOUNT	Retail
<b>WBT-0780 Economy</b>	\$18.00

WBT's least expensive binding post model featuring a unique finish of Velours Chromium and is manufactured from brass. Available terminations include crimp, solder and screw on printed circuit board. Crimp screw and set screw can be purchased separately.

CE COMPLIANT	PCB MOUNT	Retail
<b>WBT-0785 Economy – Safety Line</b>		\$20.00

The WBT-0785 is a Safety Line version of the WBT-0780.

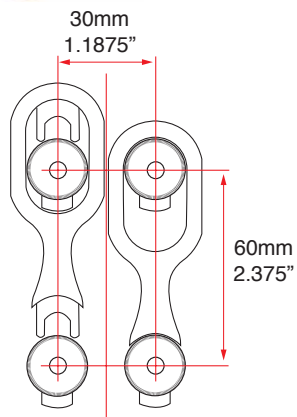
**WBT POWER BRIDGES**

	Retail
<b>WBT-0725 Cu Power Bridge - Safety Line</b> Pure copper, gold plated	\$23.00
<b>WBT-0725 Ag Power Bridge - Safety Line</b> Pure copper, platinum plated	\$46.00
<b>WBT-0726 Economy Power Bridge</b> Pure copper, velour chromium plated Non-insulated and not vibration damped	\$8.00

Designed primarily for the OEM market to meet strict European CE safety standards, the WBT-0725 Cu/Ag Power bridge replaces the brass jumpers found as standard equipment on most speakers.

Uninsulated jumpers are no longer legal in Europe as they pose a shock threat due to lack of insulation. The WBT Power Bridges address this problem as they are fully insulated with Makrolon® plastic for shock protection and, because both terminals are removed at the same time, the "live-wire" situation is avoided. The back of the Power Bridge is damped with an elastomer to minimize vibration.

Power Bridges can be used in conjunction with any WBT™ binding post (except the WBT-0702 series). When purchased with WBT™ posts, Power Bridges make an excellent modification to any bi-wire loudspeaker. Please refer to the diagram to the left for mounting dimensions.



**BINDING POSTS - INCLUDES INSULATING WASHER AND SET NUT**

ILLUSTRATIONS NOT TO SCALE

At a Glance Binding Post Comparison Chart						Termination			Available marking colors for Multichannel identification								
All terminals can be installed at 90° steps, 45° steps when used with WBT-9404 8.5 Nm torque = 6.273 Ft Lbs, 1.1 Nm torque = 0.8118 Ft Lbs						Solder	Crimp	PCB Mount	Red	Orange	Yellow	Green	Blue	Violet	White	Grey	Black
BINDING POSTS	Final body finish	External Plating, layers & thickness	Maximum Cable diameter accepted	Metallurgic properties	Special Notes												
WBT0702.01	24k Gold	Nickel free 3 layers Cu 11µm Pd 4µm Au 0.3µm	4mm <sup>2</sup> banana 1/4" spade 5/16" spade 10 AWG	68% Oxygen free copper alloy	Locking collet for 4mm <sup>2</sup> bananas Recommended torque for counter nut: 8.5Nm	●	●		●			●			○		●
WBT0702.03	Velours Chromium	Glass bead blasted 1 layer Ni 5.0µm	4mm <sup>2</sup> banana 1/4" spade 5/16" spade 10 AWG	68% Oxygen free copper alloy	Locking collet for 4mm <sup>2</sup> bananas Recommended torque for counter nut: 8.5Nm	●	●		●			●			○		●
WBT0702.11	24k Gold (highly polished)	1 layer Au 0.3µm	4mm <sup>2</sup> banana 1/4" spade 5/16" spade 10 AWG	68% Cold rolled Oxygen free copper alloy	Locking collet for 4mm <sup>2</sup> bananas Recommended torque for counter nut: 8.5Nm	●	●		●			●			○		●
WBT0702.12	Platinum (highly polished)	1 layer Pt 0.3µm	4mm <sup>2</sup> banana 1/4" spade 5/16" spade 10 AWG	68% Cold rolled Oxygen free copper alloy	Locking collet for 4mm <sup>2</sup> bananas Recommended torque for counter nut: 8.5Nm	●	●		●			●			○		●
WBT0730.01	24k Gold	Nickel free 3 layers Cu 11µm Pd 4µm Au 0.3µm	4mm <sup>2</sup> banana 1/4" spade 10 AWG	68% Oxygen free copper alloy	Recommended torque for counter nut: 8.5Nm	●	●		●			●			○		●
WBT0730.11	24k Gold (highly polished)	1 layer Au 0.3µm	4mm <sup>2</sup> banana 1/4" spade 10 AWG	68% Cold rolled Oxygen free copper alloy	Recommended torque for counter nut: 8.5Nm	●	●		●			●			○		●
WBT0730.12	Platinum (highly polished)	1 layer Pt 0.3µm	4mm <sup>2</sup> banana 1/4" spade 10 AWG	68% Cold rolled Oxygen free copper alloy	Recommended torque for counter nut: 8.5Nm	●	●		●			●			○		●
WBT0735	CE-Compliant Makrolon™ over 24k Gold	Nickel free 3 layers Cu 11µm Pd 4µm Au 0.3µm	4mm <sup>2</sup> banana 1/4" spade 10 AWG	68% Oxygen free copper alloy	Recommended torque for counter nut: 8.5Nm	●	●		●			●			○		●
WBT0763	24k Gold	3 layers Cu 1.5µm Ni 8.0µm Au 0.2µm	4mm <sup>2</sup> banana 1/4" spade 10 AWG	52% Oxygen free copper alloy	Recommended torque for counter nut: 8.5Nm	●	●		●			●			○		●
WBT0764	24k Gold	3 layers Cu 1.5µm Ni 8.0µm Au 0.2µm	4mm <sup>2</sup> banana 1/4" spade 10 AWG	52% Oxygen free copper alloy	Recommended torque for counter nut: 8.5Nm Recommended torque for PCB bolt, 1.1Nm	●		●	●			●			○		●
WBT0765	CE-Compliant Makrolon™ over 24k Gold	3 layers Cu 11µm Ni 4.0µm Au 0.3µm	4mm <sup>2</sup> banana 1/4" spade 10 AWG	52% Oxygen free copper alloy	Recommended torque for counter nut: 8.5Nm	●	●		●			●			○		●
WBT0766	CE-Compliant Makrolon™ over 24k Gold	3 layers Cu 11µm Ni 4.0µm Au 0.3µm	4mm <sup>2</sup> banana 1/4" spade 10 AWG	52% Oxygen free copper alloy	Recommended torque for counter nut: 8.5Nm Recommended torque for PCB bolt, 1.1Nm	●		●	●			●			○		●
WBT0780	Velours Chromium	Glass bead blasted 1 layer Ni 5.0µm	4mm <sup>2</sup> banana 1/4" spade 10 AWG	Brass	Recommended torque for counter nut: 8.5Nm Recommended torque for PCB bolt, 1.1Nm	●	●	●	●			●			○		●
WBT0785	CE-Compliant Makrolon™ over Velours Chromium	Glass bead blasted 1 layer Ni 5.0µm	4mm <sup>2</sup> banana 1/4" spade 10 AWG	Brass	Recommended torque for counter nut: 8.5Nm Recommended torque for PCB bolt, 1.1Nm	●	●	●	●			●			○		●

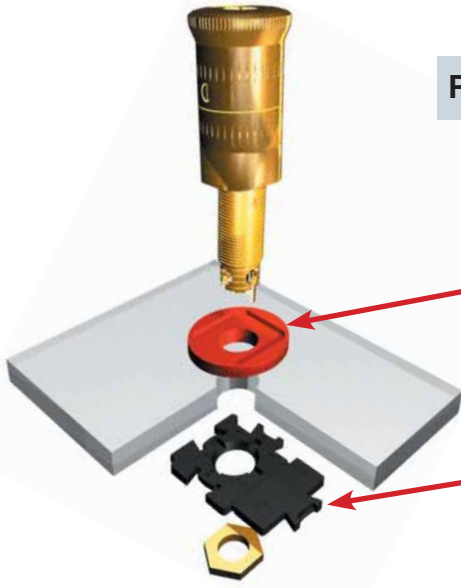
**INSULATING WASHER SETS**

**Part A + Z**

Retail

\$2.75

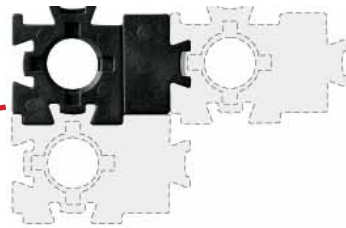

**PART A:** insulating shoulder washer fits to the body of the binding post and can be positioned at 90° increments. The “key”, which is visible, fits in a corresponding keyed hole in the panel. Color code: white, red, black, or green.

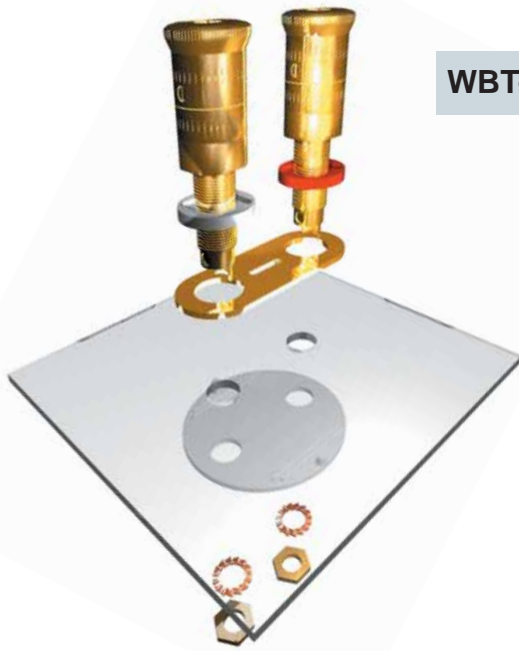

**PART Z:** is the chassis side of the insulation system. To take best advantage of the puzzle washers, at least two should be clipped together. They can be arranged to obtain either 0.75” (19mm) or 1.181” (30mm) spacing. The puzzle washer allows a very tight terminal installation on housings from 0.1 to 10mm thickness.

**WBT-0716 Thick panel mounting kit**

Retail

\$16.23

**Kit includes:**

← 1 plastic interior bracket

← 1 gold-plated brass exterior bracket

← 2 fan shaped washers

Requires counter-sinking of cabinet with a router or 50mm Forstner drill bit.

**BINDING POST ACCESSORIES**

ILLUSTRATIONS NOT TO SCALE



**WBT-0717 Holding Tool**

Retail

\$64.00

Use when mounting binding posts. Snaps into the two posts, holds them in alignment and prevents the posts from rotating while tightening the nuts.



**WBT-0799 Safety Stick**

Retail

\$0.60

Specially shaped plastic peg inserts in banana plug hole in binding post; required to accomplish CE safety conformity.



**WBT-9404 Spacer Block – 3/4" (19mm) spacing**

Retail

\$2.29

Fits all binding posts except WBT-0702 Series. 3/4" plastic insulating spacer block. Color code: red white, or black.



**WBT-0721 PCB Adapter Block**

Retail

\$7.00

Fastens to circuit board with included bolt and lock washer. Mounts horizontally or vertically. Torx™ screw fastens jumper wire terminated with crimp sleeve. Other end of lead wire connects to binding post.



**WBT-9102 Antifatigue Bolt**

Retail

\$2.86

Antifatigue bolt with fan shape washer. Can be added to WBT-0780 and WBT-0785.



**WBT-9150 Fan Shape Lock Washer**

Retail

\$1.14

Recommended addition to all WBT binding posts.



**WBT-9302 Chrome Plated Counternut, M9 thread**

Retail

\$0.91

Specialty nut only available from WBT.



**WBT-9303 Gold Plated Counternut, M9 thread**

Retail

\$1.83

Specialty nut only available from WBT.



**Replacement T-6 Torx™ Set Screws**

Retail

\$1.14

Available 4mm-8mm lengths. Please specify size when ordering.

**MOUNTING PLATE ASSEMBLIES**

ILLUSTRATIONS NOT TO SCALE

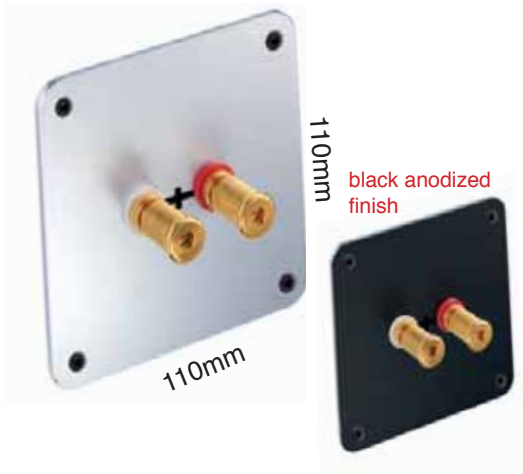
**WBT-510.05 Two post assembly**

Clear anodized aluminum finish.

Retail

\$91.00

**WBT-510.06 Two post assembly**

Black anodized finish.

\$91.00

Anodized aluminum plate with two WBT-0763 Midline posts. Includes a closed cell foam rubber gasket.

**WBT-511.05 Two post assembly**

Clear anodized aluminum finish.

Retail

\$175.00

**WBT-511.06 Two post assembly**

Black anodized finish.

\$175.00

Anodized aluminum plate with two WBT-0763 Midline posts. Includes a closed cell foam rubber gasket.

**WBT-512.05 Two post assembly**

Clear anodized aluminum finish.

Retail

\$182.00

**WBT-512.06 Two post assembly**

Black anodized finish.

\$182.00

Anodized aluminum plate with two WBT-0763 Midline posts. Includes a closed cell foam rubber gasket.

**WBT-522.05 Two post assembly**

Clear anodized aluminum finish.

Retail

\$200.00

**WBT-522.06 Two post assembly**

Black anodized finish.

\$200.00

Anodized aluminum plate with two WBT-0765 safety line posts. Includes a closed cell foam rubber gasket.





**MOUNTING PLATES**

ILLUSTRATIONS NOT TO SCALE

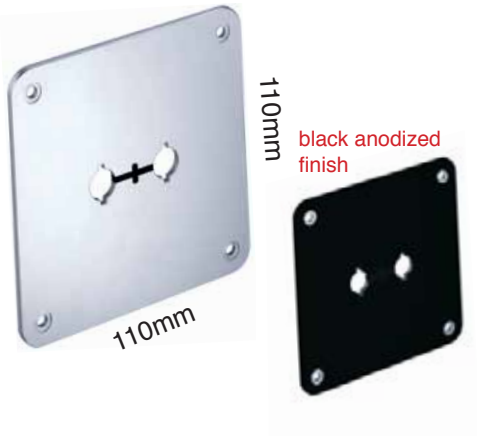

**WBT-530.05**  
Clear anodized aluminum finish.

Retail

\$63.00

**WBT-530.06**  
Black anodized finish.

\$63.00

Punched for 2 posts. Includes a closed cell foam rubber gasket.



**WBT-531.05 (Bi-Wire)**  
Clear anodized aluminum finish.

Retail

\$81.00

**WBT-531.06 (Bi-Wire)**  
Black anodized finish.

\$81.00

Punched for 4 posts. Includes a closed cell foam rubber gasket.



**WBT-532.05 (Bi-Wire)**  
Clear anodized aluminum finish.

Retail

\$91.00

**WBT-532.06 (Bi-Wire)**  
Black anodized finish.

\$91.00

Punched for 4 posts. Includes a closed cell foam rubber gasket.

Custom Laser engraving of graphics and/or text available for all Mounting Plates. Call for Pricing.



**TOOLS**

**ILLUSTRATIONS NOT TO SCALE**



**WBT-0299 RCA Socket Wrench**

Retail

\$44.00

Specially designed for tightening the mounting nut on WBT™ RCA type sockets. Spike on tool fits into hole in mounting nut. Permits tightening without scratching the nut or socket.



**WBT-0488 Torx™ Key**

Retail

\$6.00

T-6 size fits all WBT™ Set Screws.



**WBT-0403 Crimping Pliers**

Retail

\$90.00

Crimping pliers with special multiple spike jaw. The only tool designed to correctly crimp WBT™ crimp sleeves. Gold-plating protects against corrosion. Comfortable, plastic-coated grip.



**WBT-0499 Cutting Shears**

Retail

\$90.00

Shear cuts through fine-strand copper cable up to #5AWG with a cleaving action for a clean even cut. Gold-plating protects against corrosion. With a little practice, also good for stripping speaker cables.

**WBT™ BITS FOR TORQUE SCREW DRIVER**



WBT-0485 SLOT BITS —	WBT-0485 PHILLIPS BITS +	WBT-0485 TORX™ BITS ★	WBT-0485 HEX BITS ●
Available Sizes 1.5mm 2.0mm 2.5mm 3.0mm 3.5mm* 4.0mm*	Available Sizes 000 00 0 1	Available Sizes T6 T7 T8 T10 T15* T20*	Available Sizes 1.3mm — 0.050" 1.5mm — 0.059" 1.59mm — 1/16" 2.0mm — 5/64" 2.38mm — 3/32" 2.5mm — 0.098" 3.0mm* — 0.118" 4.0mm* — 0.157"
*Not included in the WBT-0484 Bit-Set. Special Order Only.			

**WBT-0484 Bit-Set**

Bit Set (18 types).

Retail

\$165.00

**WBT-0485/XXX**

Choice of any one bit from the above list.

\$9.50



**TOOLS**

ILLUSTRATIONS NOT TO SCALE



**WBT-0481 Torque Screwdriver**

Retail

\$200.00

The WBT-0481 is a precision torque screwdriver with an elegant design. Torque is set to 5 dNm for precise tightening of all WBT parts utilizing the Torx™ T-6 size. 4mm<sup>2</sup> hole in the end for an attachment of a ground lead, if a static electricity ground is needed. Includes one T-6 Torx™ bit.



**WBT-0411 Crimp KIT**

Retail

\$230.00

Includes one WBT-0403 crimping pliers and an assortment of copper crimp sleeves in a convenient carrying case. Silver sleeves sold separately. Copper sleeves included with the WBT-0411 are as follows:

- 20 pcs WBT-0430 20 AWG (uninsulated)
- 20 pcs WBT-0431 18-19 AWG (uninsulated)
- 20 pcs WBT-0432 17 AWG (uninsulated)
- 20 pcs WBT-0433 15-16 AWG (uninsulated)
- 20 pcs WBT-0442 14-13 AWG
- 20 pcs WBT-0443 11-12 AWG
- 20 pcs WBT-0444 9-10 AWG
- 10 pcs WBT-0445 7-8 AWG



**WBT-0490 Torque Screwdriver Set**

Retail

\$320.00

This kit includes one WBT-0481 Dyna-key along with the WBT-0484 bit assortment in a jewel case for keeping it all together. Additional bits are available separately.

**WBT™ SILVER SOLDER**

All WBT™ Solder is the highest quality solder with 4% fine silver content. The halogen-free flux is gentle on precious metal surfaces. The melting temperature is extremely low at 180°C / 356°F.

**WBT-0840 Silver Solder 4% Ag**

Retail

\$105.00

1.2mm diameter      500grams / 1.140 lbs.      57m / 187'

**WBT-0820 Silver Solder 4% Ag**

Retail

\$60.00

0.8mm diameter      250grams / 0.575 lbs.      73m / 239'

**WBT-0800 Silver Solder 4% Ag**

Retail

\$20.00

0.9mm diameter      42grams / 0.123 lbs.      10m / 32.8'









**CRIMP SLEEVES**

ILLUSTRATIONS ARE TO SCALE





WBT™ cable end sleeves are made of special oxygen-free copper or pure fine silver. Available in all standard sizes from 0.5mm<sup>2</sup> - 16mm<sup>2</sup>, also with transparent insulation collar from 1.5mm<sup>2</sup> - 16mm<sup>2</sup>. Insulated sleeves provide additional cable strain relief. Available in bulk bags, assortments or single pieces. Copper sleeves are 24k gold plated and silver sleeves are platinum plated.

WBT™ Crimp Sleeves	mm <sup>2</sup>	AWG	Per Each Sleeve
			Retail
 WBT-0430	0.5	#20	\$0.60
 WBT-0431	0.75	#19	\$0.60
 WBT-0432	1.0	#17	\$0.60
 WBT-0433	1.5	#16	\$0.60
 WBT-0434	2.5	#14	\$0.60
 WBT-0435	4.0	#12	\$0.90
 WBT-0436	6.0	#10	\$0.90
 WBT-0437	10.0	#8	\$0.90
 WBT-0438	16.0	#6	\$1.25

**WBT™ Crimp Sleeves with Insulated Collar**

 WBT-0441	1.5	#16	\$1.25
 WBT-0442	2.5	#14	\$1.25
 WBT-0443	4.0	#12	\$1.25
 WBT-0444	6.0	#10	\$1.75
 WBT-0445	10.0	#8	\$1.75
 WBT-0446	16.0	#6	\$2.50

**WBT™ Silver Crimp Sleeves with Insulated Collar**

 WBT-0450	1.5	#16	\$4.60
 WBT-0451	2.5	#14	\$5.75
 WBT-0452	4.0	#12	\$6.90
 WBT-0453	6.0	#10	\$8.00



Assortment in plastic box dispensers.

**WBT-0470 Crimp Sleeve Assortment**

1 bag each of WBT-0430, 31, 32, 33,34, 41 & 42

\$245.00

**WBT-0471 Crimp Sleeve Assortment**

1 bag each of WBT-0435, 36, 37 & 38

\$200.00

**WBT-0472 Crimp Sleeve Assortment**

1 bag each of WBT-0443, 44, 45 & 46

\$130.00



## CRIMPING TECHNIQUE

ILLUSTRATIONS NOT TO SCALE

WBT's crimping technique has been designed to ensure a high quality and durable crimp. For the procedure itself, one must strip the desired cable and insert it into the proper size crimp sleeve. Then, carefully place the wire and sleeve into the proper slot on the crimper and apply a powerful squeeze. WBT's unique crimp tool design creates a crescent shaped crimp which forces the wire to flow together, thus creating the illusion of a single strand of wire. Trim the sleeve, including the wire, to the desired length to fit the application. When using one of WBT's solderless connectors, simply loosen the set screw on the connector then insert the crimped end of the cable into the connector, tighten using the Torx™ bit.



Wire is stripped and the appropriate size crimp sleeve is slid onto the strands.



Sleeve is then crimped onto wire with crimping pliers.



The result should look like this.



Use WBT-0499 cutters to trim crimped wire end to fit in WBT™ crimp technique connector.

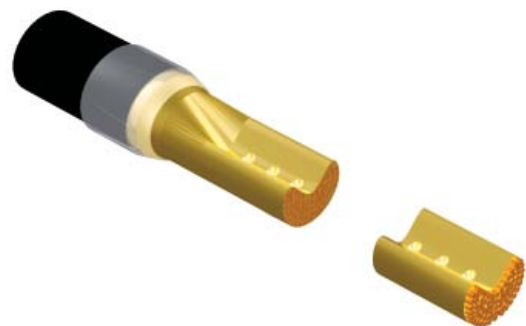

Crimped cable end ready for use in WBT™ crimp technique connectors.



**Wall Mount Impedance Matching Volume Control**

- » For use with any combination of 4Ω or 8Ω speakers.
- » 43 watts RMS, 126 watts average
- » Attenuation: 10 steps
- » Mounting: single gang junction box
- » Screw type terminals

**VC-126I Price Each \$27.50**



**FoculPods Isolation Feet \$20.00 for a set of 4.**  
Great for isolating vibrations from equipment or speakers.



**Decorative Port Trim Rings**  
2COVER 2" ID \$2.00  
3COVER 3" ID \$2.00  
4COVER 4" ID \$2.50



**Flared Ports 3" & 4" ID**  
Flared on both ends. 17" long max length. Cut center to fit.  
**3FLARE \$12.00 each**  
Flange diameter 6 1/4"  
**4FLARE \$14.00 each**  
Flange diameter 7 1/4"



**2" ID Flared Port**  
Flared on both ends. Use either end as outer flare. 11" long max length, 5.25" flange  
**2FLARE \$8.80 each**



**PEGLOCK Grill Fastener \$0.25 each** for a peg and socket. Use 3/8" drill for peg & socket. Nylon, very strong material.



**HEDLOCK Grill Fastener \$0.25 each** for a ball and socket. Use 37/64" or 14.5mm for Socket. Use 7/16" or 11mm for Ball.

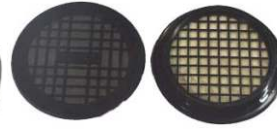

**SSV Scan speak vent \$6.00 each**  
Scan-speak aperiodic vents are used in sealed boxes to reduce the system Q of the box. SSV's allow you to reduce your box size by about 25%. Use one up to 1 of and 2 or more for larger boxes. 4.3" cut-out diameter



**T-Nut & Blk Allen Head Screws**  
6-32 x 1" \$0.30 each  
8-32 x 1" \$0.35 each  
10-24 x 1 1/2" \$0.35 each  
1/4-20 x 1 3/4" \$0.40 each



**YSC Cone Tiptoe \$1.25 each**  
Chrome plated metallic gray color, including t-nut. 5/8" tall with metric M6 shaft (not 1/4-20)



**YSC1/4-20 Chrome Tiptoe \$1.25 each**  
**YSCG Gold Plate Tiptoe \$1.30 each**  
Black Chrome or Gold plated, including foot. 5/8" tall with 1/4-20 shaft & insert.



**YLC Cone Tiptoe \$1.65 each**  
Chrome plated metallic gray color, including t-nut. 1-3/8" tall with metric M6 shaft (not 1/4-20)



**YLC1/4-20 Chrom Tiptoe \$1.65 each.**  
**YLCG Gold Plate Tiptoe \$1.70 each.**  
Chrome or Gold plated. 1-3/8" tall with 1/4-20 shaft and threaded insert.



**YT Set of 4 Tiptoe \$2.40 set**  
1/4" tiptoe x 1 3/4" long with threaded inserts and lock nuts. Use pointed or flat end.



**YBT Set of 4 Tiptoe \$4.75 set**  
3/8"-20 tiptoe x 2 1/8" long with threaded inserts and lock nuts. Use pointed or flat end.



**FT Fowler Tiptoe \$2.00 each or 10% off for a set of 8 pieces.**  
1/4-20 shaft x 1 3/4" long. Threaded insert and lock nut.



**FBT Fowler Tiptoe \$3.00 each or 10% off for a set of 8 pieces.**  
3/8-20 shaft x 2 1/8" long. Threaded insert and lock nut.

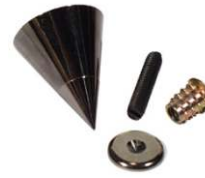

**YBSC Chrome Tiptoe \$4.55 each**  
**YBSCG Gold Tiptoe \$4.85 each**  
**1.5" Tall**



**YBLC Chrome Tiptoe \$4.95 each**  
**YBLCG Gold Tiptoe \$5.20 each**  
**2.15" Tall**

Great for heavy speakers, Black Chrome plated brass, 1.25" diameter at base. Tiptoe, 1/4-20 threaded stud, threaded insert, foot pad. Perfect for large speakers or subwoofers. Could be used without tip.



**YSCGA Gold Plated Height Adjustable TipToe. \$3.95 Each.**  
1" (25mm) diameter, 1.1" to 1.38" height. Gold plated foot. Pad for foot & double stick tape to mount.



**YRF Rubber Foot \$0.80 each**  
1.45" OD (37mm)  
0.78" Tall (20mm)  
1/4" hole (6mm)



**Felt Diffraction Ring for tweeters, 1/8" thick; \$2.00 each.**  
4.37" (111mm) OD  
1.62" (41mm) ID



**LP15 15W 8Ω L-pad \$2.75 ea**  
1" shaft length, 1.6" Ø body  
**LP15-3/4 15W 8Ω L-pad \$2.75 ea**  
- 3/4" shaft length, 1.6" Ø body  
**LP100 100W 8Ω L-pad \$5.75 ea**  
3/4" shaft length, 2.45" Ø body



**LP50 50Watt 8Ω L-pad \$7.85 each**  
3/4" long shaft, 2" square body, Attenuation 0 to 40dB. Cast aluminum top plate. Terminal one is ground to speaker and crossover. Terminal 2 to speaker plus. Terminal 3 to crossover T or M plus.



**YG-Spade Red or Black \$1.35 each**  
All brass gold plated. Will accept wire with a jacket diameter up to 6mm. Spade opening stepped at 3mm, 5mm & 6mm. Spade blade thickness 2.1mm

Assorted Speaker Needs	
Grill Cloth, Black and Brown, 66" wide x #yards	7.00 /yd
Polyester fiberfill 16oz bag	3.60
Polyester 1" Batting 3'x8'	6.00
Acoustic Foam Sheets (27" x 42" x 5/8")	5.60
Virgin Audio Wool per pound	10.50
Acousta-stuf per pound	9.50
Screws.... Black #10 x 1" Pan head	.04
Screws.... Black #8 x 1" Pan head	.04
Screws....Black #6 x " Truss head	.04
Screws....Black #6 x 1/2" Pan head	.04
Screws....Black #6 x 3/4" Pan head	.04
Screws.... Black #6 x 3/4" Oval head	.04
1/8" Black Felt, adhesive backed by the foot, 32" wide	\$15.00 / ft
Gasket Material:1/2" x 1/8" Foam adhesive tape	.15/foot

Custom Cut PVC Ducts - Cream Color Piping			
Diameter ID	Less than 6"	6"-11.9"	12"-18"
1 Inch	\$1.75	\$2.75	\$3.75
1 1/2 Inch	\$2.00	\$3.00	\$4.00
2 Inch	\$2.00	\$3.00	\$4.00
2 1/2 Inch	\$2.25	\$3.25	\$4.25
3 Inch	\$2.50	\$3.50	\$4.50
4 Inch	\$3.00	\$4.00	\$5.00

We will cut to the exact length you need.



**CB-CUP Input Cup \$1.85 each**  
 Chrome plated posts with plastic knobs and threaded inserts. Accepts banana plugs or 8 Awg. Wire. The cup is 3.15" square with a round 2.7" cut-out hole size.



**GB-CUP Input Cup \$2.35 each**  
 Gold plated posts with plastic knobs and threaded inserts. Accepts banana plugs or 8 Awg. wire. The cup is 3.15" square with a round 2.7" cut-out hole size.



**DB-CUP Input Cup \$3.55 each**  
 All brass gold plated posts with knurled caps. Accepts banana plugs or 4 Awg wire. The cup is 3.15" square with a round 2.7" cut-out hole size.



**D-CUP Input Cup \$3.55 each**  
 All brass gold plated posts with knurled caps. Accepts banana plugs or 4 Awg wire. The cup is 4.14" round with a 3" round hole size.



**R-CUP Input Cup \$3.90 each**  
 All brass gold plated posts with hexagonal caps. Accepts banana plugs or 4 Awg wire. The cup is 4.14" round with a 3" round hole size.



**G25-CUP Input Cup \$7.70 each**  
 All brass gold plated (25mm Ø) posts with ribbed caps. Accepts banana plugs or 2 Awg wire. The plate is 4.73" long by 1.97" wide. Cut-out, buy it first and decide.



**TD-CUP Input Cup \$9.20 each**  
 All brass gold plated posts with ribbed caps and straps for bi-wire applications. Accepts banana plugs or 4 Awg wire. The cup is 4.73" tall by 3.66" wide. Cut-out 3.7" x 2.9".



**N-POST Terminal \$0.90 each**  
 Chrome plated posts with metal inserted plastic knobs. Accepts 7 Awg wire. 1/2" long shaft. Red or Black.



**G-POST Terminal \$1.25 each**  
 All brass gold plated with knurled head. Accepts bananas or 4 Awg wire. Shaft length 1/2". Specify Red or Black.



**G-POSTL Terminal \$1.45 each**  
 All brass gold plated with knurled head. Accepts bananas or 4 Awg wire. Shaft length 1". Specify Red or Black.



**HG-POST Terminal \$1.75 each**  
 All brass gold plated with Hex head. Accepts bananas or 4 Awg wire. Shaft length 1". Specify Red or Black.



**BG-POST Terminal \$2.10 each**  
 All brass gold plated with ribbed head. Accepts bananas, spades or 4 Awg wire. Shaft length 1". Specify Red or Black.



**YG-POST Terminal \$1.55 each**  
 All brass gold plated with knurled head. Accepts bananas, spades or 4 Awg wire. Shaft length 1.65". Specify Red or Black.



**SG-POST Safety Terminal \$1.90**  
 Gold plated posts with clear plastic protection. Meets CE regulation. Available in Red or Black. 30mm long shaft. 5mm cable entry hole



**EG-SPLUG Banana \$2.45 each.**  
 All brass gold plated single banana plug. Accepts 6 Awg wire (5mm Ø). Has two set screws. Specify Red or Black.



**EG-PLUG Banana \$6.50 each.**  
 All brass gold plated dual banana plug with a standard 3/4" spacing. Accepts 6 Awg wire. Wire is fastened by screw down head.





# Computer Aided Crossover Design

Crossover design has significantly evolved in the last decade. In the past you had to start with a theoretical design and then spend weeks tweaking until you came up with a crossover that sounded pretty good, but probably was not as good as it could be. Madisound has now developed the art of crossover design, providing the customer with a fully developed filter system in a fraction of the time necessary using older methods.

Madisound begins by taking all driver response and impedance measurements in our anechoic chamber using the Audio Precision measurement system. We then export this data into the Leap filter analysis program by Linearx. With the Leap program we can plot what would be an ideal curve for each driver, and then use Leap to try different filter values against the actual driver response curves, continually selecting those parts that bring the actual curve to that of the ideal curve. We then look at the total system response curve and select parts to match the ideal system response. The result is a flat response curve, to the limits of the selected driver responses. This method can be repeated for impedance correction to create an ideal impedance magnitude response. The finished design is excellent, and a good value!

We are designing with Leap version 4.6.

## The following curves are provided with each Leap design order:

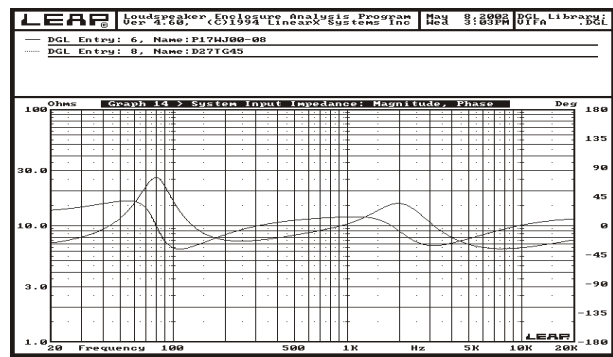
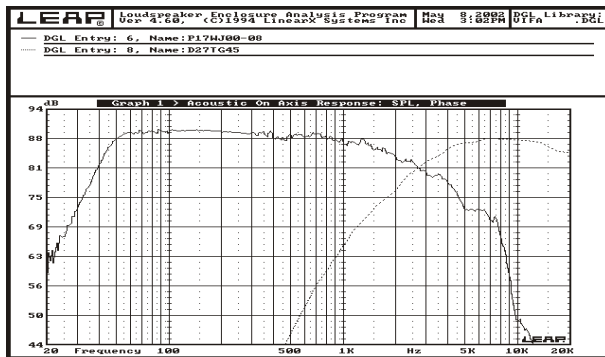
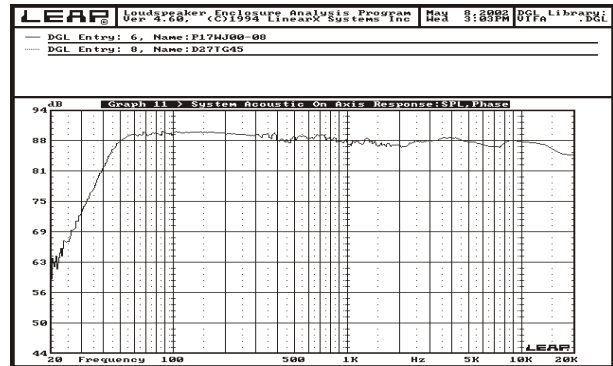
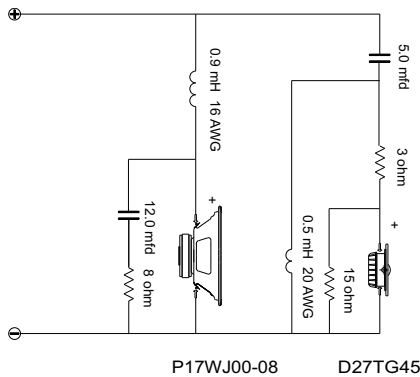

## To place an order for a Leap design, Madisound we need to know the following:

- › What drivers are you using? They must be Madisound stock items. (In the case of 3 or 4 way systems, we could just use the woofers technical parameters.)
- › What are your box volumes, or do you wish us to determine them for you?
- › Are the drivers surface mounted, or routed into the cabinet for a flush mount? ( Flush recommended)
- › What slopes (6dB, 12dB, 18dB, 24dB) would you like us to design for, or would you prefer we choose?
- › Do you prefer a flat response, tapered response or relaxed midrange response?
- › What quality of inductors will you use? We will model using the DCR of the coils.

## Leap Design Pricing (Design only, not an assembled crossover)

2-Way Design	\$25.00	Sub /Sat Design	\$35.00	Special requests or projects?
3-Way Design	\$40.00	MTM 2-Way	\$30.00	Ask about pricing.
4-Way Design	\$55.00			



# NORDOST

Nordost is well known for their superior quality speaker cables and interconnects. Whatever product you choose, you should hear a noticeable improvement in sound quality.

There are too many products for us to give complete specs and reviews. All information is available on the Nordost web site at [www.nordost.com](http://www.nordost.com).

## BULK WIRE by the FOOT (3.3ft = 1M)

### 2 Flat Speaker Cable (two conductor)

2FL/ft Running foot \$3.29

### 4 Flat Speaker Cable (four conductor)

4FL/ft Running foot \$6.59

### Flatline Gold MK II Speaker Cable (eight conductor)

FL/ft Running foot \$5.49

### Super Flatline MK II Bi-Wire Cable (sixteen conductor)

SF/ft Running foot \$10.99

## CONNECTORS

NZGB8 8 pcs Z gold banana w/boots \$38.49

NGS8 8pcs gold spade w/boots \$54.99

FLO21 Flatline stripping tool \$33.29

## SPEAKER CABLE PAIRS

*Available in Z-plug bananas & spades - Same Price*

### Flatline MKII Speaker Cable

FL2MB 2M Pair w / bananas \$143.99

FL3MB 3M Pair w / bananas \$183.69

FL4MB 4M Pair w / bananas \$224.39

FL5MB 5M Pair w / bananas \$265.09

Add for each additional 1/2M pair \$20.35

### Super Flatline MKII Bi-Wire Speaker Cable

SF2MB/BW 2M Pair w / bananas \$274.99

SF3MB/BW 3M Pair w / bananas \$356.39

SF4MB/BW 4M Pair w / bananas \$437.79

SF5MB/BW 5M Pair w / bananas \$519.19

Add for each additional 1/2M pair \$40.70

### Blue Heaven Rev II Bi-Wire Speaker Cable

BH2MB/BW Rev II 2M Pair w / bananas Bi-Wire \$439.99

BH3MB/BW Rev II 3M Pair w / bananas Bi-Wire \$579.99

BH4MB/BW Rev II 4M Pair w / bananas Bi-Wire \$719.99

BH5MB/BW Rev II 5M Pair w / bananas Bi-Wire \$859.99

Add for each additional 1/2M pair \$70.00

### Red Dawn Rev II Bi-Wire Speaker Cable

RD2MB/BW Rev II 2M Pair w / bananas Bi-Wire \$779.99

RD3MB/BW Rev II 3M Pair w / bananas Bi-Wire \$989.99

RD4MB/BW Rev II 4M Pair w / bananas Bi-Wire \$1199.99

RD5MB/BW Rev II 5M Pair w / bananas Bi-Wire \$1409.99

Add for each additional 1/2M pair \$105.00

## INTERCONNECTS

*XLR termination is an additional \$30.00 DIN to RCA pair  
\$60.00 DIN to DIN pair.*

### Blue Heaven Interconnect

BH0.6MR 0.6M Pair with RCA \$175.00

BH1MR 1M Pair with RCA \$210.00

BH1.5MR 1.5M Pair with RCA \$260.00

Add for each additional 1/2M pair \$50.00

### Red Dawn Interconnect

RD0.6MR 0.6M Pair with RCA \$330.00

RD1MR 1M Pair with RCA \$400.00

RD1.5MR 1.5M Pair with RCA \$480.00

Add for each additional 1/2M pair \$80.00

### Silver Screen HD Composite Video

SSC1-1MR 1M with RCA \$167.49

SSC1-2MR 2M with RCA \$203.49

Add for each additional 1/2M \$18.00

### Silver Screen HD S-Video

SSC2-1MSV 1M with S-Video \$285.99

SSC2-2MSV 2M with S-Video \$355.99

Add for each additional 1/2M \$35.00

### Silver Screen HD Component Video

SSC3-1MR 1M with RCA \$412.49

SSC3-2MR 2M with RCA \$511.49

Add for each additional 1/2M \$49.50

### Silver Screen HD RGB Video

SSC5-1MR 1M with RCA or BNC \$659.99

SSC5-2MR 2M with RCA or BNC \$824.99

Add for each additional 1/2M \$82.50

### Silver Screen DVI Video

SSCDVI-1.5M 1.5M with DVI \$349.99

SSCDVI-2M 2M with DVI \$439.99

SSCDVI-3M 3M with DVI \$599.99

SSCDVI-5M 5M with DVI \$919.99

## FIBER OPTIC CABLES

### Glass Fiber Optic Cable - Toslinks

WLG-1M 1M with Toslink \$189.99

WLG-1.5M 1.5M with Toslink \$217.49

## POWER CORDS

### Shiva Power Cable

SHPWR-2M Power Cord 2 meter \$300.00

SHPWR-3M Power Cord 3 meter \$400.00

Add for each additional Meter \$100.00

### Vishnu Power Cable

VIPWR-2M Power Cord 2 meter \$600.00

VIPWR-3M Power Cord 3 meter \$800.00

Add for each additional Meter \$200.00

**Most speaker cables are available as bi-wire, bi-amp or shotgun, for the same price.**

# SUPRA<sup>®</sup> Cables

MADE IN SWEDEN

Supra has been manufacturing cables, in-house from their facilities in Sweden, since 1976. Prior to 1976, cables had no identity, they were just "cables". In 1976 Supra introduced the "Supra 2.5", beginning a new trend in branded cables.

Supra has since greatly expanded their lines, creating new cables for each new trend in the audio industry. We invite you to visit the Supra web site for more information, or download the Supra catalog from our web site: "[www.jenving.se](http://www.jenving.se)" in Sweden or "[www.tonianlabs.com](http://www.tonianlabs.com)" in the US. Both web sites contain many reviews of the Supra products in order to assist you in deciding which cables to purchase.

We will stock bulk wire, terminations and some of the most popular pre-terminated cables. Cables we don't stock will take a little longer and may be drop shipped directly to the customer. We feel that Supra offers some of the best values in the industry.

Item	Description	Price
------	-------------	-------

### Supra Lorad Screened Power Cables: Ice Blue, Each

LORAD 3X2.5 S5	5ft Supra EU Schuko Plug	\$179.40
LORAD 3X2.5 W5	5ft Wattgate US Plug	\$207.00
LORAD 3X2.5 W6	6ft Wattgate US Plug	\$230.00

### Supra Sword Bifilar Wound Litz Speaker Cable: Ice Blue, Pair in Mahogany Case

Sword 8 ft	8ft Pair with Combicon Kit	\$867.10
Sword 10ft	10ft Pair with Combicon Kit	\$1097.10
Sword 12ft	12ft Pair with Combicon Kit	\$1,327.10
Sword 14ft	14ft Pair with Combicon Kit	\$1,557.10
Additional Per Foot		\$200.00

### Supra Classic & Rondo Speaker Cable: Ice Blue

Classic 1.6	by the foot (15AWG)	\$0.80
Classic 2.5	by the foot (13AWG)	\$1.46
Rondo 2x2.5	by the foot (2x13AWG)	\$1.72
Rondo 4x2.5	by the foot (4x13AWG)	\$3.44

### Supra Ply Speaker Cable: Ice Blue

PLY2.0/FT	by the foot (14AWG)	\$6.60
PLY3.4/FT	by the foot (12AWG)	\$7.92
PLY3.4-S8	8ft Pair with Spades	\$172.00
PLY3.4-B8	8ft Pair with Bananas	\$196.00
PLY3.4-S10	10ft Pair with Spades	\$208.00

Item	Description	Price
PLY3.4-B10	10ft Pair with Bananas	\$230.00
PLY3.4-S12	12ft Pair with Spades	\$242.00
PLY3.4-B12	12ft Pair with Bananas	\$266.00

### Bi-Wire PLY 3.4 Speaker Cable: Ice Blue in white nylon sleeve

PLY3.4BW-S8	8ft Pair with Spades	\$312.00
PLY3.4BW-B8	8ft Pair with Bananas	\$334.00
PLY3.4BW-S10	10ft Pair with Spades	\$368.00
PLY3.4BW-B10	10ft Pair with Bananas	\$392.00
PLY3.4BW-S12	12ft Pair with Spades	\$450.00
PLY3.4BW-B12	12ft Pair with Bananas	\$472.00

### Screened Supra Ply Speaker Cable with ground wire: Ice Blue

PLY3.4/S	(328ft) by the foot (12AWG)	\$9.24
PLY3.4/S-S6	6ft Pair with Spades	\$162.00
PLY3.4/S-B6	6ft Pair with Bananas	\$184.00
PLY3.4/S-S8	8ft Pair with Spades	\$208.00
PLY3.4/S-B8	8ft Pair with Bananas	\$230.00
PLY3.4/S-S10	10ft Pair with Spades	\$254.00
PLY3.4/S-B10	10ft Pair with Bananas	\$276.00
PLY3.4/S-S12	12ft Pair with Spades	\$300.00
PLY3.4/S-B12	12ft Pair with Bananas	\$322.00

### HDMI & DVI Cables

HDMI-HDMI 1M	1 Meter Single (3.3')	\$82.80
HDMI-HDMI 2M	2 Meter Single (6.5')	\$89.70
HDMI-HDMI 4M	4 Meter Single (13.1')	\$110.40
HDMI-HDMI 8M	8 Meter Single (26.2')	\$172.50
HDMI-HDMI 12M	12 Meter Single (39.3')	\$227.70
HDMI-HDMI 15M	15 Meter Single (49.2')	\$241.50
HDMI-DVI 1M	1 Meter Single (3.3')	\$73.60
HDMI-DVI 2M	2 Meter Single (6.5')	\$82.80
HDMI-DVI 4M	4 Meter Single (13.1')	\$101.20
HDMI-DVI 8M	8 Meter Single (26.2')	\$149.50
HDMI-DVI 12M	12 Meter Single (39.3')	\$204.70
HDMI-DVI 15M	15 Meter Single (49.2')	\$232.30
DVI-DVI 1M	1 Meter Single (3.3')	\$66.70
DVI-DVI 2M	2 Meter Single (6.5')	\$75.90
DVI-DVI 4M	4 Meter Single (13.1')	\$105.80
DVI-DVI 8M	8 Meter Single (26.2')	\$186.30
DVI-DVI 12M	12 Meter Single (39.3')	\$232.30
DVI-DVI 15M	15 Meter Single (49.2')	\$264.50

# SUPRA<sup>®</sup> Cables

MADE IN SWEDEN

Item	Description	Price
<b>Supra Analogue Interconnect Pairs: EFF-I Cable and PPX RCA's or Supra XLR's as "-XLR"</b>		
EFF-IX-1M	1 Meter Pair	\$230.00
EFF-IX -1.5M	1.5 Meter Pair	\$264.50
EFF-IX-2M	2 Meter Pair	\$287.50
<b>Sublink Interconnects with RCA-6</b>		
SUBLINK 2M	2 Meter Single	\$62.10
SUBLINK 4M	4 Meter Single	\$75.90
SUBLINK 8M	8 Meter Single	\$96.60
<b>Y-LINK Interconnects with Single RCA to Dual RCA</b>		
Y-LINK 2M	2 Meter Single	\$96.60
Y-LINK 4M	4 Meter Single	\$110.40
Y-LINK 8M	8 Meter Single	\$138.00
<b>BiLine Interconnects with Single Mini-jack to Dual RCA- For Computer Connection to Stereo</b>		
BILINE 1M	1 Meter Single	\$82.80
BILINE 2M	2 Meter Single	\$89.70
BILINE 4M	4 Meter Single	\$110.40
BILINE 8M	8 Meter Single	\$138.00
<b>Supra Zac Fiber Optic Cable with Toslinks</b>		
TOSLINK 1M	1 Meter Single	\$65.56
TOSLINK 2M	2 Meter Single	\$82.80
TOSLINK 4M	4 Meter Single	\$105.22
TOSLINK 8M	8 Meter Single	\$151.80
<b>Supra Composite Video Interconnects with Trico Cable and PPX RCA's</b>		
TRICO-RCA 1M	1 Meter Single	\$89.70
TRICO-RCA 2M	2 Meter Single	\$110.40
TRICO-RCA 4M	4 Meter Single	\$138.00
TRICO-RCA 8M	8 Meter Single	\$207.00
<b>Supra Composite Video Interconnects with Trico Cable and BNC connectors</b>		
TRICO-BNC 1M	1 Meter Single	\$82.80
TRICO-BNC 2M	2 Meter Single	\$103.50
<b>Supra S-Video to RCA Interconnects with AV-2 Cable</b>		
AV2-Svideo 1M	1 Meter Single	\$75.90
AV2-Svideo 2M	2 Meter Single	\$82.80
AV2-Svideo 4M	4 Meter Single	\$103.50
AV2-Svideo 8M	8 Meter Single	\$138.00

Item	Description	Price
<b>Supra Component Video/Audio Interconnects with AV-3 Cable and 3 RCA (BNC same price)</b>		
AV3-RCA 1M	1 Meter RCA to RCA	\$131.10
AV3-RCA 2M	2 Meter RCA to RCA	\$144.90
AV3-RCA 4M	4 Meter RCA to RCA	\$172.50
AV3-RCA 8M	8 Meter RCA to RCA	\$220.80
<b>Supra Connectors</b>		
Banana	2 pairs	\$38.40
Fork XL	2 pairs	\$24.00
Boxcon	1 pair insulated binding post	\$43.20
CombiCon Banana	2 pairs Bananas	\$45.00
CombiCon Spade	2 pairs of Spades	\$45.00
CombiCon Kit	2 pairs body, 4 spades/bananas	\$80.00
BNC	2 pieces	\$28.80
PPSL	RCA pair w/ squeeze locking	\$36.00
PPX	RCA pair (8.5mm cable)	\$28.80
MP-8	3.5mm Mini Plug (2pcs)	\$21.60
RCA-6	RCA pair (5-6mm cable)	\$16.80
RCA-3	RCA pair (3mm cable)	\$16.80
SVHS-7	S-Video pair	\$19.20

Supra's comprehensive collection of cables is too numerous for us to describe in detail within these catalog pages. Please do your research on the web.

The **Lorad power cables** are very popular, providing a shielded connection to the wall outlet.

The **Supra Classic** and **Rondo cables** are used for both internal and external wiring. The shielded version is more often used for external wiring, reducing the effects of stray field noise.

**Sword cables** are made with bifilar litz winding, where an inner set of helically wound wire is run in one direction and an outer set in another direction. This divides the fields in opposing directions, cancelling the magnet field. Sword behaves as a non-inductive and phase stable cable. Sword cables come with interchangeable CombiCon connectors, providing both spade and banana termination.

**Supra interconnect** options are vast. You should be able to find a connection to fit your particular needs.

**Tin vs Silver**, Supra cables are plated with a high purity Tin instead of Silver. Tin is of a higher resistance than Silver, so the signal travels through the copper and not on the plating. Tin also has a minimized dielectric effect by acting as a semi-Litz.

# GOERTZ SPEAKER CABLES

- **GOERTZ HT 14AWG COPPER**

Easy to install under carpeting and behind baseboards.

**On the spot termination:** Termination may be performed using the Goertz Rhodium plated connectors or the G-HT may be notched to form integral spades which will fit into the screw terminals. In both cases no soldering is required. The notching pliers are available to buy in "Accessories."

- **GOERTZ MI 1 13AWG COPPER (AG 1 SILVER 12AWG)**

The original Goertz cable, MI 1 in 13 gauge (AWG) solid Oxygen Free Copper (OFC) or 12 gauge AG 1 in solid High Purity Silver. The heavy, high purity Oxygen Free Copper (OFC) or solid high purity silver ribbons are sandwiched together, separated only by micro-thin layers of film insulation. The minute amount of active dielectric also provides rapid break-in; now audiophiles don't have to wait tens of hours to break in their cables, Goertz cables produce immediate results!

- **GOERTZ MI 2 10AWG COPPER (AG 2 SILVER 9AWG)**

MI 2 Heavy 10 gauge OFC copper or 9 gauge AG 2 solid silver cabling for improved bass and power handling over the remarkable Goertz MI 1. Great reviews confirm that this remarkable cable really delivers; superb bass control, vivid mid-range, and excellent high frequency extension combine with rejection of interference and no break-in period. Simply great value.

- **GOERTZ MI 3 7AWG COPPER (AG 3 SILVER 7AWG)**

Alpha-Core's "Big Boy" 7 gauge speaker cable; the answer for powerful audiophile systems. MI 3 was designed for high power amplifiers driving full range speakers. Perhaps the best speaker cable made today, the MI 3 delivers sublime clarity, dynamics, and definition throughout the audio spectrum. The extreme low DC resistance ensures diaphragm control for tight, powerful bass and mid-range, and the low inductance carries distortion free high frequencies and crucial harmonics for outstanding imaging and depth perception.

- **PYTHON MI 2**, the first Serpent, is electrically and sonically equivalent with the popular **GOERTZ MI2**. It contains four film insulated flat, solid OFC copper conductors sandwiched intimately on top of one another and then twisted and embedded in a cylindrical, solid jacket of high grade polymer. The resin is cast in place to totally support and protect the flat conductor bundle, meaning that **Python** can take any amount of punishment and still sound and look like new.

- **BOA** cables are larger gauge versions of the Serpent cables.

## HT, MI, & AG SPEAKER CABLE PAIR

MODEL	SINGLE per foot	BI-WIRE per foot
<b>COPPER CABLE "CU"</b>		
HT 'Home Theater' (14AWG)	\$8.39	\$16.77
MI1 'Center Stage' (13AWG)	\$12.40	\$24.80
MI2 'Veracity' (10AWG)	\$21.50	\$43.00
MI3 'Divinity' (7AWG)	\$53.00	\$106.00
<b>SILVER CABLE "AG"</b>		
AG1 'Center Stage' (12AWG)	\$73.20	\$146.40
AG2 'Veracity' (9AWG)	\$128.70	\$257.40
AG3 'Divinity' (7AWG)	\$275.60	\$550.00
<b>Add Termination Cost</b>		
Rhodium Spades, Bananas, Pins	\$40.00	\$63.00
Silver Spades	\$58.00	\$85.00

## PYTHON & BOA CABLE PAIR

MODEL	SINGLE per foot	BI-WIRE per foot
<b>COPPER CABLE "CU"</b>		
PYTHON MI2 (10AWG)	\$28.00	\$28.00
BOA MI3 (7AWG)	\$69.00	\$69.00
<b>SILVER CABLE "AG"</b>		
PYTHON AG2 (9AWG)	\$161.00	\$161.00
BOA AG3 (7AWG)	\$344.50	\$344.50
<b>COPPER &amp; SILVER HYBRID "CU&amp;AG"</b>		
PYTHON HYBRID (10AWG)	\$94.50	\$94.50
BOA HYBRID (7AWG)	\$206.75	\$206.75
<b>Add Termination Cost</b>		
Rhodium Spades, Bananas, Pins	\$40.00	\$63.00
Silver Spades	\$58.00	\$85.00

## CABLE CONNECTORS

MODEL	PRICE
RHODIUM SPADES (4)	\$24.00
RHODIUM BANANAS (4)	\$24.00
RHODIUM PINS (4)	\$24.00
SILVER SPADES KIT 1/2" x 5/16" (4)	\$40.00
SILVER SPADES KIT 5/16" x 5/32" (4)	\$27.00

## TO CALCULATE TOTAL PRICE:

- DETERMINE PRICE FOR 1' PAIR IN SINGLE OR BI-WIRE
- MULTIPLY THE LENGTH YOU NEED WITH CORRESPONDING PRICE/FOOT PAIR
- ADD THE TERMINATION PRICE
- TOTAL PRICE=[(PRICE/FT. PAIR X LENGTH) + TERMINATION COST]



# ALPHA-CORE INTERCONNECTS

- **‘TOURMALINE’ COPPER**

Two thin 18 gauge high purity Oxygen Free Copper (OFC) conductors are sandwiched together, separated only by micro-thin layers of film insulation. The minute amount of active dielectric also provides virtually no break-in!

- **‘MICRO PURL’, COPPER AND SILVER**

The revolutionary Micro Purl is cutting-edge transmission line technology. It contains two 50 microns thick by 2mm wide signal carriers made of solid fine silver or OFC Copper, placed on each side of a copper ground plane. The ultra thin three layer sandwich is then twisted (purl) as it is embedded in a heavy sheath of transparent high grade polymer. The twisting facilitates handling and further enhances EM and RF rejection. Micro Purl is breaking new ground as professional quality microphone and patch cables, and as digital interconnects. AWG 26.

- **TQ 2 ‘TRIODE QUARTZ’ SOLID FINE SILVER**

The new TQ 2 is made in similar fashion as Micro Purl, by twisting the bundle of solid fine silver conductors and copper ground plane in line with the extrusion of a tough, crystal clear jacket of high grade polymer. The result may be coiled and handled like any other cable and will take considerable punishment without equivalent to AWG 22, and the overall diameter is .32" versus .25" for Micro Purl. The electrical parameters and sonic characteristics are the same as those of TQ 1 except for the fact that the in-line twist has further improved the EMI and RF noise rejection inherent in the low inductance geometry.

- **‘SAPPHIRE’ SILVER**

Two thin 18 gauge 99.99% pure solid fine silver conductors are sandwiched together in the unique Goertz configuration. Impervious to extraneous line frequency and RF fields, with the great ultra clean sound of solid fine silver.

## INTERCONNECT CABLE PAIR

MODEL	0.5M	1M	1.5M	2M	2.5M	3M	4M	5M
<b>COPPER INTERCONNECTS “CU”</b>								
TOURMALINE RCA	\$92.00	\$137.00	\$175.00	\$216.00	\$258.00	\$299.00	\$352.00	\$410.00
TOURMALINE XLR	\$131.00	\$180.00	\$224.00	\$270.00	\$316.00	\$363.00	\$424.00	\$492.00
MICRO PURL CU-RCA	\$52.00	\$78.00	\$93.00	\$121.00	\$149.00	\$166.00	\$196.00	\$257.00
MICRO PURL CU-XLR	\$74.00	\$103.00	\$128.00	\$155.00	\$187.00	\$207.00	\$244.00	\$312.00
<b>SILVER INTERCONNECTS “AG”</b>								
MICRO PURL AG-RCA	\$85.00	\$127.00	\$152.00	\$197.00	\$243.00	\$270.00	\$320.00	\$419.00
MICRO PURL AG-XLR	\$121.00	\$167.00	\$208.00	\$252.00	\$305.00	\$337.00	\$398.00	\$508.00
TRIODE QUARTZ TQ2 RCA	\$125.00	\$186.00	\$238.00	\$293.00	\$350.00	\$406.00	\$478.00	\$557.00
TRIODE QUARTZ TQ2 XLR	\$178.00	\$245.00	\$304.00	\$366.00	\$428.00	\$492.00	\$576.00	\$668.00
SAPPHIRE RCA	\$193.00	\$341.00	\$487.00	\$619.00	\$652.00	\$685.00	\$914.00	\$1,145.00
SAPPHIRE XLR	\$256.00	\$435.00	\$610.00	\$769.00	\$800.00	\$864.00	\$1,118.00	\$1,340.00

## INTERCONNECT TERMINATION

MODEL	PRICE
24 KARAT GOLD PLATED TIP RCA (4)	\$28.00
RHODIUM PLATED XLR (4)	\$37.00
SOLID SILVER RCA AG2K (4)	\$180.00

## OTHER ACCESSORIES

MODEL	PRICE
HEAT SHRINK SLEEVES (6)	\$2.00
GOERTZ SPADE CUTTER	\$8.95
SILVER SOLDER 1 LB. SPOOL	\$42.00



# Words of Wisdom for Speaker Builders

*“For the inexperienced builder...the best single reference available...”*

—Robert M. Bullock, III  
Contributing Editor, *Speaker Builder*

SEVENTH EDITION

## The Loud Speaker Design Cookbook

by Vance Dickason

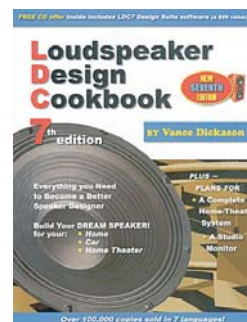

Publisher's price \$39.95  
Madisound Price \$35.00

### Twelve Chapters (275 pages, soft bound)

0. How Loudspeakers Work
1. Closed-Box Low-Frequency Systems
2. Vented-Box Low-Frequency Systems
3. Passive-Radiator Low-Frequency Systems
4. Transmission Line Low-Frequency Systems
5. Cabinet Construction: Shape and Damping
6. Loudspeaker Baffles: Driver Locations, Separation and other Considerations
7. Passive and Active Crossovers
8. Loudspeaker Testing
9. Cad Software for Loudspeaker Design and Loudspeaker Room Interfacing
10. Home Theater Loudspeakers
11. Car Audio Loudspeakers
12. Two System Designs: Home Theater and a Studio Monitor

## TESTING LOUDSPEAKERS

by Joseph D'Appolito

- ◆ Seven Chapters
- ◆ 174 pages

**Publishers Price \$34.95**  
Madisound's Price \$30.00

Testing Loudspeakers is the first comprehensive and solidly authoritative account of just how loudspeakers may be reliably tested. Ultimately, accurate results from testing will lead to better designs. The measurement techniques contained in this book provide all clues you need to refine your speaker's components to improve its performance. The author spells out in his first chapter:

“To my knowledge, there is currently no well-organized tutorial reference on loudspeaker testing for the experienced hobbyist or technician. This book is intended to fill that gap.”

## Speaker Building 201

*A comprehensive course in speaker design.*

by Ray Alden

### Twelve Chapters, (153 pages, soft bound)

Chapters 1 through 10 provide a basic knowledge of speakers and speaker building. Starting with the basic of how a speaker works, to building the correct enclosure for your speaker and basics in speaker crossover design. There is also a chapter on speaker design software and speaker testing.

The Final two chapters have specific details on building 11 different speaker systems

This book has many photos, illustrations and graphs to aid you in understanding the speaker building process.

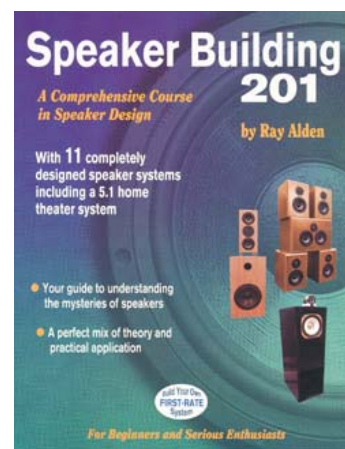

Madisound's Price  
\$30.00

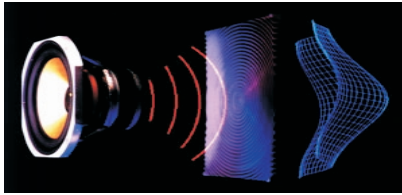

# Spectra Dynamics

## ACOUSTIC PANEL TECHNOLOGY

### Deflex Panel and Deflex Subwoofer Panel

	<u>Standard Panel</u>	<u>Subwoofer Panel</u>
Material.....	Advanced polymer	Advanced polymer
Color.....	Charcoal grey	Charcoal grey
Surface emulation.....	Spherical concave	Spherical concave
Defined radius - nominal.	200 mm	300 mm
Focal point - nominal.....	100 mm	150 mm
Thickness at center.....	5 mm (maximum)	12 mm (maximum)
Max. edge thickness.....	12 mm	12 mm
Overall dimensions.....	280mm x 210mm	340 mm Ø Round
Density / hardness.....	1.36 / < 15° A	1.36 / < 15° A
Rebound resilience.....	< 15%	< 15%

The polymer is specially formulated to absorb shock and vibration, thus minimizing cabinet resonances.

The surface emulation has been carefully designed to help eliminate standing waves.

Independent tests on MLSSA show an energy gain of over 50%.

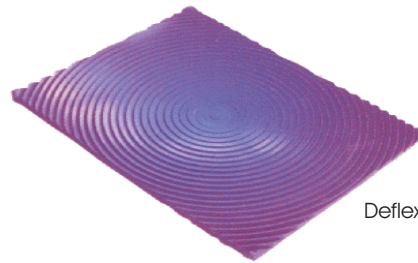

Deflex Standard Panel

### Foculpod Isolation Feet

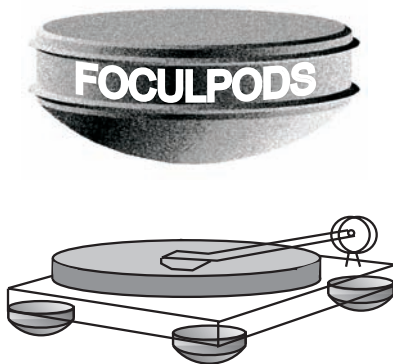

Diameter: 50 mm  
Height: 20 mm

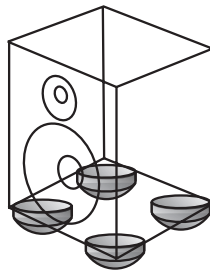

"...A marked improvement was obvious from the  
"...The special surface pattern reduces standing waves to cure boxiness and resonance without killing the vitality of the sound..."  
"...expect tighter cleaner bass, crisper articulation, and an increase in liveliness without loss of control..."  
"...The result was sharper imaging, wider dynamics and a more natural sound..."  
*HI-FI Choice - January 1994*

"...Deflex panels seemed to give greater tightness and control, improved internal clarity, and better pitch definition - all without deadening the sound in any way..."  
*Audiophile - January 1994*

**" THE ONLY CURE FOR  
BOX NOISE AND  
STANDING WAVES "**

### CURRENT PRICE LIST

Standard Panel	@ \$ 11.00	each
Sub-woofer Panel	@ \$ 20.00	each
Foculpods	@ \$ 20.00	set of 4
Weldbond	@ \$ 2.70	4 oz. bottle

We recommend Weldbond as an adhesive to attach the Panels. Wash the panel first; let dry; smear Weldbond on panel and cabinet; when tacky, attach.

MADISOUND SPEAKER COMPONENTS  
8608 UNIVERSITY GREEN  
P.O. BOX 44283  
MADISON, WI 53744-4283 U.S.A.  
TEL: 608-831-3433 FAX: 608-831-3771  
e-mail: madisound@itis.com  
Web Page: <http://www.itis.com/madisound>





KG-5230 Sub Amp

# Keiga Subwoofer Amplifiers and 2.1 Media Amplifier

- ➔ **KG-3100: 50W & (2x) 25W @ 4Ω**
- ➔ **KG-5150: 200 Watts @ 4 Ω**
- ➔ **KG-5230: 300 Watts @ 4 Ω**



KG-5150 Sub Amp

The **KG-5150 and KG-5230** are plate **Subwoofer Amplifiers with Electronic Crossovers** for building powered subwoofer systems. These amps have adjustable electronic crossovers and have enough power to deliver good bass without added distortion. We are confident that we now have products that can meet the demands of both home theater or high end audio systems. Powered subwoofers are a versatile addition to your audio system. With the variable crossover and volume control, you can match a subwoofer to any existing system. These amplifiers can be used with single or multiple woofer systems (a total impedance of 4 to 8 ohms is recommended). The crossover can be turned off if you are using the amplifier with a system that already has a built in crossover.

- **Class AB**
- **Discrete high current drivers and output devices**
- **Woofer volume control**
- **50Hz to 100Hz continuously adjustable low pass 12dB electronic crossover**
- **Crossover on/off switch**
- **Low and High level input, summed to mono signal**
- **Low and High level all pass output**
- **Phase inverter switch**
- **Master power switch**
- **Auto power on/off activated by input signal**
- **4dB boost @ 25Hz, 15Hz High pass**

The **KG-3100 2.1 Amplifier** was developed for small sub/sat systems. The amp is designed to be built into the subwoofer enclosure and then out to the satellite speakers. You can use the built in **electronic crossover** to divide the frequencies between the amp and the satellites. The electronic crossover is continuously variable from **75Hz to 150Hz**. There is a master volume control and a volume control for just the subwoofer. The amplifier will accept either **RCA inputs** or **3.5mm Mini Jack inputs**. If you are using the mini jack inputs, you can purchase a separate desktop volume control for use with your computer.



KG-3100 2.1 Amp



KG-VC Volume Control

The KG-3100 is the perfect choice to build a system for your computer, MP3 player, portable CD player, office or small apartment.

- **X-over LP + HP: 75Hz - 150Hz**
- **Rear plastic cover**
- **Master & woofer volume controls**
- **Switchable bass boost 3dB@40Hz**
- **Auto on control**
- **GP Binding Posts for Sat. Outs**
- **Separate KG-VC desktop mini jack volume control for \$15.85.**

Specifications:	KG-5150	KG-5230	KG-3100
Power output Watt@ 4 ohms	200	300	50 & 2x25
THD	0.05%	0.08%	0.08%
S/N ratio @ rated power	85dB	85dB	76dB
Input sensitivity @ 100Hz - low level	75mV	75mV	80mV
Input sensitivity @ 100Hz - high level	3.5V	3.5V	3.5V
Input impedance	22k ohms	22k ohms	22k ohms
Variable Low Pass Crossover Freq.	50-100Hz	50-100Hz	75-150Hz
Weight	10.5 lbs	14.5 lbs	7.6 lbs
Dimensions W x H inches	11 <sup>7/16</sup> x 8 <sup>1/4</sup>	9 <sup>7/8</sup> x 9 <sup>7/8</sup>	8 <sup>11/16</sup> x 7 <sup>7/8</sup>
Cutout hole W x H inches	10 <sup>7/16</sup> x 7 <sup>1/4</sup>	8 <sup>7/8</sup> x 8 <sup>7/8</sup>	7 <sup>11/16</sup> x 6 <sup>7/8</sup>
AC Voltage	115	115 / 230 switchable	115 / 230 switchable
<b>Price Each</b>	<b>\$169.00</b>	<b>\$225.00</b>	<b>\$136.00</b>





# KGND5250 (500W) & KGND52100 (1000W) Class D Subwoofer Plate Amplifiers

Madisound is pleased to offer these powerful Class D amplifiers. A Class D amplifier is a switching amplifier that converts a low level analog signal into a high power pulse width modulated output. The **KGND52100 is 86% efficient and the KGND5250 is 82% efficient**; inherent in the Class D design and the **efficient power supply**. The 1950 watt peak analog power supply is a cleaner power source than switching power supplies found in most other Class D amplifiers. The Keiga Class D amps also have **very low standby power consumption of 1 watt**, which meets new European standards. Because of its efficiency, these amps produce very little heat. The Keiga Class D Amps use the **ICEPower® modules, developed by Bang @ Olufsen Powerhouse a/s**. The amps are equipped with a protective casing on the back, not shown in this picture.



KGND52100

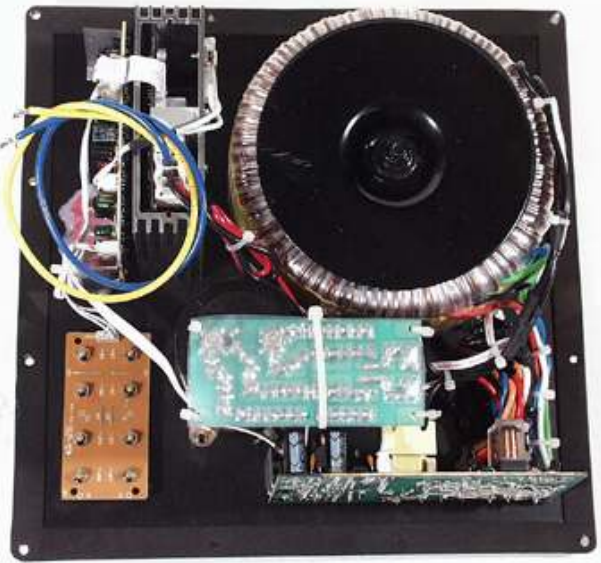

### Features:

- Very high efficiency Class D amplifier; high current Mosfet output devices.
- Low pass frequency adjustable 50~100Hz.
- Woofer level control.
- 180° Phase invert switch.
- Auto on control, switchable.
- Very low standby power.
- Thermal protection
- Master power switch.
- LFE input.
- RCA in/out (out has no crossover).
- Speaker level in/out (out has no crossover).
- IEC power socket.
- LED power indicator.
- AC 115V/230V switchable.

### Specifications:

	5250	52100
• Power output @ 10% THD, 4 ohms	600W	1200W
• Power output @ 1% THD, 4 ohms	500W	1000W
• T.H.D.	0.08%	0.08%
• S/N ratio @ rated power	80dB	90dB
• Input sensitivity @ 100Hz		
(RCA) low level	150 mv	190mv
(Speaker) high level	3.5v	4.2v
• Input impedance	22k Ω	22k Ω
• Variable low pass frequency	50~100Hz	50~100Hz
• Efficiency	82%	86%
• Standby power consumption	1W	1W
• Dimensions		
Width	12"	12"
Height	12"	12"
Depth	4.5"	4.5"
• Weight	9.0kg	13.5kg
• Price Each	\$350	\$510

# POWERED SUBWOOFER KITS

Madisound has put together several exceptional subwoofer designs to produce Do-It-Yourself Sub Kits with simple assembly and top quality components. We have chosen drivers from Eclipse, Soncraft and Foster to combine with the clean power of the Keiga amplifier make for an attractive and versatile designs. The cabinets are compact for easy room placement and suitable for home hi-fidelity or for home theater applications. Despite the small box size the low resonance of these subwoofers will allow for clean reproduction of movie soundtrack transients down to 25Hz. The cabinets are professionally finished with solid rounded oak corners, completely assembled, and are already cut and vented. Front baffles are 1" thick, all other sides 3/4". The cabinet comes with a black grill. Your choice of clear or black lacquered oak veneer. (Clear finish shown below). The graphs shown are simulated frequency responses. Actual frequency response will vary depending on the dimensions of the listening environment.

## Eclipse Powered Subwoofer Kit

Price Each \$355.00 (w/o cabinet \$215.00)



18" deep x 16" tall x 14" wide

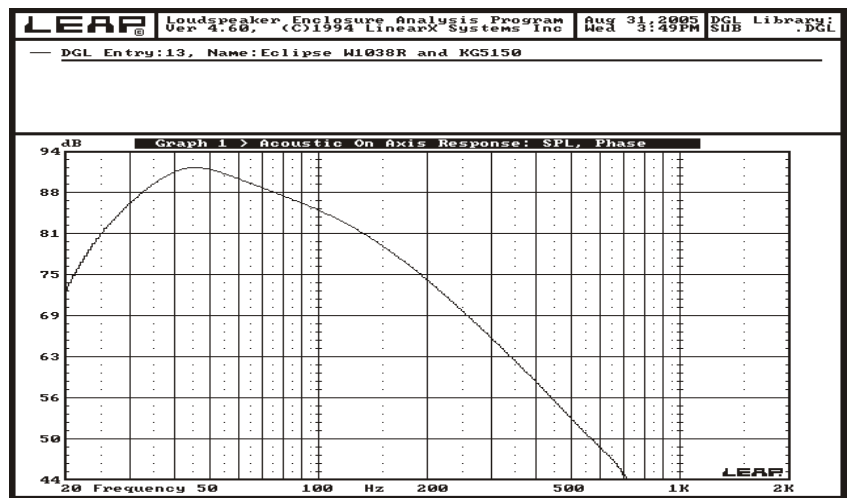

## SC12 & NHT1259 Powered Subwoofer Kits

SC12 Price Each \$480.00 (w/o cabinet \$285.00)



18" deep x 28.25" high x 15.5" wide

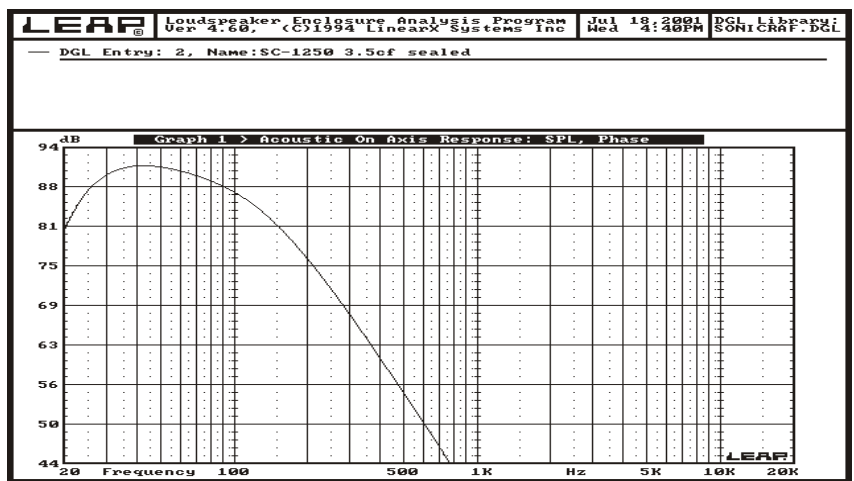

### Options:

SC12 with 300 watt KG5230 amplifier \$530.40 (w/o cab \$335.40)

NHT1259 woofer with KG5150 amp \$502.50 (w/o cab \$307.50)

NHT1259 woofer with KG5230 amp \$552.90 (w/o cab \$357.90)

## Woodstyle Cabinets - Dimensions W x H x D

Woodstye cabinets feature real oak veneer with solid rounded oak corners. Front and back are black lacquered with a black grill mounted with hedlocks on the front and a cutout for the input-cup on the back. Woodstyle cabinets are skillfully crafted from 3/4" high density particle board, veneered on both sides with oak veneer and joined virtually seamlessly to the solid oak corners. Cabinets may also be purchased as singles for half the pair price.

WS602 Oak, Black Oak, Cherry	5.3 Liters, 8"x12"x7", grill w/ Fastex Fasteners, approx. 20 lb./pr cut for CB/GB-cup	\$110 / pair
WS802 Oak, Black Oak	11.6 Liters, 10"x16"x8", grill; w/ Fastex Fasteners, approx. 30 lb./pr cut for CB/GB/DB-cup	\$120 / pair
WS802 REV Oak, Black Oak	11.6 Liters, 8"x16"x10", grill; w/ Fastex Fasteners, approx. 30 lb./pr cut for CB/GB/DB-cup	\$125 / pair
WS803 Oak, Black Oak, Cherry	24.9 Liters, 12"x19"x10.5", grill w/ Fastex Fasteners, approx. 26 lb./each cut for CB/GB/DB-cup	\$160 / pair
WS803 REV Oak, Black Oak, Cherry	24.9 Liters, 10.25" x 19" x 12", grill w/ Fastex Fasteners, approx. 26 lb./each cut for CB/GB/DB-cup	\$175 / pair
WS123 Oak, Black Oak	48.8 Liters, 14.5"x25"x12", grill w/ Fastex Fasteners, approx. 38 lb./each cut for CB/GB-cup	\$190 / pair
WS123 REV Oak, Black Oak, Cherry	48.8 Liters, 12"x25"x14.5", grill w/ Fastex Fasteners, approx. 38 lb./each cut for CB/GB-cup	\$210 / pair
WS120 Oak, Black Oak	61.7 Liters Subwoofer box, 17.75"x18.25"x15.75", grill w/ Fastex Fasteners, approx. 47 lb., VL-cup	\$102 / each
NHT - Oak, Black Oak, Cherry	93.4 liters, 15.5" x 28.5" x 17.75", 1" front baffle, grills, approx. 68lb, Cut for 12" & TD-Cup	\$195 / each
NHT_5150 - Oak, Black Oak	93.4 liters, 15.5" x 28.5" x 17.75", 1" front baffle, grills, approx. 68lb, Cut for 12" & KG5150 Amplifier	\$195 / each
NHT_5230 - Oak, Black Oak, Cherry	93.4 liters, 15.5" x 28.5" x 17.75", 1" front baffle, grills, approx. 68lb, Cut for 12" & KG5230 Amplifier	\$195 / each



WS602



WS802



WS802R



WS803



WS803R



WS123



WS123R - Cherry



WS120



WS802R in Black



WSNHT

The kit cabinets we have can also be purchased separately without the kit parts. They will be cut out for the kit parts.



# DESCANT *IN-WALL & IN-CEILING SPEAKERS*

Madisound is pleased to offer Descant architectural sound systems for wall and ceiling installation. We think this is an excellent approach to hi-fi sound, without the requirement of significant space for loudspeaker placement. Descant speakers are a good choice for Audio, Video or Commercial applications.

The spin out clamps allow easy installation. Using the template provided, simply cut a hole in the drywall or paneling. Attach the speaker wire to the input terminals and clamp the wall material between the grill frame and the clamps. **New Construction kits** are available for all but the square flange coaxial for **\$19.00 a pair**.

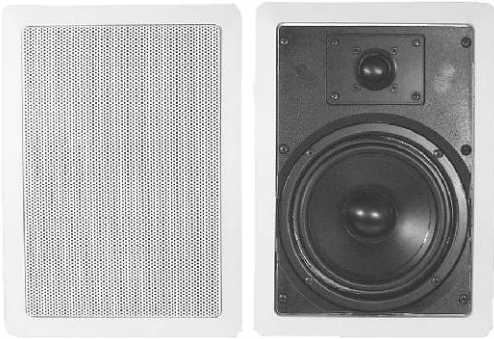

## **TW-625 6.5" 2-Way \$155.00 / pair**

The TW-625 is a 2-way speaker using a 6.5" polypropylene cone woofer with a rubber surround. The tweeter has a 1" textile dome. The crossovers are designed with 6dB parts on the woofer and 12dB parts on the tweeter, resulting in 12dB mirrored slopes. Good choice for in wall applications.

### Specifications:

Impedance:	8 ohm	Sensitivity:	90dB
Frequency:	55 to 20KHz	Color:	white
Power :	40 Watts	X-over freq.:	3KHz
Dimension: 12" tall x 8 1/2" wide x 3 1/2" deep			

## **RCX-619 6.5" Coaxial 2-Way \$155 / pair**

### **RCX-825 & SCX-825 8" Coaxial 2-Way \$170 / pair**

The RCX-825 (round) and SCX-825 (square) coaxial speakers are constructed with an 8" polypropylene cone woofer with rubber surround and a pivotal 1" textile dome tweeter. The crossovers are designed with 12dB parts on the woofer and 6dB parts on the tweeter, resulting in 12dB mirrored slopes.

The RCX-619 (round) has a polypropylene cone with a rubber surround and pivotal 3/4" textile dome tweeter. The crossover is 12dB/12dB.

The concentric design of a coaxial speaker makes this systems suitable for mounting in the ceiling. With the tweeter mounted in the center of the woofer, no matter where you are standing in relationship to the speaker, you will be equal distance from both the woofer and tweeter. This system performs equally as well when mounted in the wall.



### Specifications RCX-825 & SCX-825:

Impedance:	8 ohm	Sensitivity:	88dB
Frequency:	45 to 20kHz	Color:	white
Power:	75 Watts	X-over freq.:	3.5kHz
Dimensions R800: 10 3/4" diameter x 3 1/2" deep			
Dimensions SQ800: 10 1/16" square x 3 1/2" deep			

### Specifications RCX-619:

Impedance:	8 ohm	Sensitivity:	89dB
Frequency:	65 to 20kHz	Color:	white
Power:	50 Watts		
X-over freq.:	3.5kHz		
Dimension:	9" diameter x 2 7/8" deep		

## **RCX-619CH \$89.00 Each**

This is a chambered version of the RCX-619. The fire rated plastic chamber will allow this speaker to be used in many installations requiring a fire resistant chamber.



## **RCX-825CH \$97.00 Each**

This is a chambered version of the RCX-825. The fire rated plastic chamber will allow this speaker to be used in many installations requiring a fire resistant chamber.





# DESCANT *INDOOR/OUTDOOR ON-WALL SPEAKER or SHIELDED MONITOR / AV SPEAKER*

Madisound is pleased to introduce the Descant On-wall or Shielded Monitor speaker. We developed the TR-525 in response to a need for an on-wall speaker that would be functional, yet uncompromising in sound quality. We experimented with many different loudspeakers until we discovered a weather resistant polymer coated paper cone woofer, that gave us the vocal midrange clarity we were looking for, without sacrificing bass response. The TR-525's versatility allow it to be used for numerous applications.

The weatherproof cabinet with U-shaped mounting bracket and weather resistant loudspeakers allow the TR-525 to be mounted outdoors. Consider using them by the pool, patio or any other area you use for outdoor entertaining. The TR-525 is also suitable for commercial outdoor applications, in theme parks, gardens, etc.

Since the TR-525 is magnetically shielded, you may use it next to a computer or TV screen. Consider using it for your surround sound system or add an amplifier to your computer system and use it as a monitor.



The TR-525 can be used as a monitor speaker, either standing upright or on its side. The fully shielded speaker allows for placement next to your TV or computer monitor. The cabinets are available either all black or all white.



The TR-525 comes with a mounting bracket to allow wall or ceiling mounting. The Bracket can be rotating to direct the speaker to the correct listening location. You may mount the speaker vertically or horizontally.



## Specifications:

- **Indoor / Outdoor**
- **Shielded magnets for use near computer monitor or TV screen**
- **Stand alone or wall/ceiling mount (mounting bracket included)**
- **5 1/4" Polymer sealed paper cone woofer**
- **3/4" Titanium dome tweeter**
- **Durable plastic cabinet with metal grill**
- **Can be mounted vertically or horizontally**
- **10" tall x 7.25" wide (front) 2.75" wide (back) x 6.5" deep**
- **6dB/12dB crossover with poly cap on the tweeter**
- **Nominal 8 ohm impedance**
- **80 watts max. Power handling**

**TR-525 Price \$155.00 per pair  
Specify white or black.**



# ACCUTON by Thiel & Partner



Unit	Description	$\Omega$	Fs Hz	dB	Watt w/xover	Box Ltrs Sealed/Vented	F3 Hz	Price Each
<b>Tweeters</b>								
<b>D20-6</b>	3/4" Diamond Dome Tweeter	6	900	89.5	200			\$2,600.00
<b>D30-6</b>	1.2" Diamond Dome Tweeter	6	440	90	300			\$4,300.00
<b>C12-6</b>	1" Ceramic Dome Tweeter	6	700	89.5	120			\$195.00
<b>C13-6</b>	1" Ceramic Dome, Neo Magnet	6	1250	92	120			\$232.00
<b>C23-6</b>	1.2" Ceramic Dome Tweeter	6	350	89.5	100			\$225.00
<b>C24-6</b>	1.2" Ceramic Dome, Neo Mag.	6	825	92	100			\$270.00
<b>Midranges</b>								
<b>C44-8</b>	2" Ceramic Dome Midrange	8	390	88.5	100			\$235.00
<b>C79-6</b>	3" Ceramic Dome Midrange	6	96	88.5	120			\$290.00
<b>C90-T6</b>	6.5" Ceramic Mid, Neo Magnet	6	73	93.2	120	2S / 3V	180 / 120	\$460.00
<b>Bass/Midranges, Woofers &amp; Passive Radiators</b>								
<b>C82-T8</b>	5" Ceramic Bass-Midrange Rnd	8	34	90	120	3S / 5V	100 / 60	\$200.00
<b>C89-T6</b>	5" Ceramic Bass-Midrange Sq	6	33.6	89.2	100	2.5S / 3V	110 / 80	\$305.00
<b>C92-6</b>	7" Ceramic Bass-Midrange Rnd	6	29	86	130	29S	49	\$230.00
<b>C95-T6</b>	7" Ceramic Bass-Midrange Rnd	6	32	89.1	130	6.5S / 9V	80 / 57	\$275.00
<b>C220-T6</b>	8" Ceramic Woofer Rnd	6	20.4	89.6	150	25S / 38V	53 / 36	\$420.00

The Accuton Ceramic Inverted Domes are made by a unique electro-chemical manufacturing process out of aluminum foil, which leads to very thin, form-stable diaphragms of Al<sub>2</sub>O<sub>3</sub> in Sapphire lattice with high internal damping. This feature is very important and responsible for very low coloration and distortion, un-achieved by other membrane materials. The well balanced concave shape yields wide and uniform energy distribution, which is far more important than high on axis sound pressure.

## D20-6



- 3/4" PURE DIAMOND DOME TWEETER
- Response to @100kHz
- Extremely low harmonic distortion
- High sound propagation
- Ferrofluid loaded
- Flange 82 x 82mm
- Cut-out 64x 64mm
- Depth 56mm

## D30-6

No Picture  
Looks like D20-6

- 1" PURE DIAMOND DOME TWEETER
- Response to @60kHz
- Extremely low harmonic distortion
- High sound propagation
- Ferrofluid loaded
- Flange 82 x 82mm
- Cut-out 64x 64mm
- Depth 56mm

Znom 6 ohm  
Re 6.0 ohm  
Le@1kHz 0.04 mH  
fs 900 Hz  
Qms -  
Qes -  
Qts -  
Mms 0.09 g  
Cms - mm/N

Sd 6.0 cm<sup>2</sup>  
BL - N/A  
Vas - ltrs  
Xmax - mm peak  
VC Ø 18.9 mm  
Sensitivity 1W / 1m 89.5 dB  
Nom. Power 200 W  
Net weight 430 g

Znom 6 ohm  
Re 6.0 ohm  
Le@1kHz 0.04 mH  
fs 440 Hz  
Qms -  
Qes -  
Qts -  
Mms 0.19 g  
Cms - mm/N

Sd 8.4 cm<sup>2</sup>  
BL - N/A  
Vas - ltrs  
Xmax - mm peak  
VC Ø 18.9 mm  
Sensitivity 1W / 1m 90 dB  
Nom. Power 300 W  
Net weight - g



No Graph Yet

## C12-6



- 1" CERAMIC DOME TWEETER
- Response to @30kHz
- Great as supertweeter or in 2-Way system
- Heavy zinc frontplate
- Ferrofluid loaded
- Flange 82 x 82mm
- Cut-out 64 x 64mm
- Depth 56mm

Znom	6	ohm	Sd	6.1	cm <sup>2</sup>
Re	6.0	ohm	BL	-	N/A
Le@1kHz	0.04	mH	Vas	-	ltrs
fs	700	Hz	Xmax	-	mm peak
Qms	-		VC Ø	16.4	mm
Qes	-		Sensitivity		
Qts	-		1W / 1m	89.5	dB
Mms	.2	g	Nom. Power	120	W
Cms	-	mm/N	Net weight	530	g

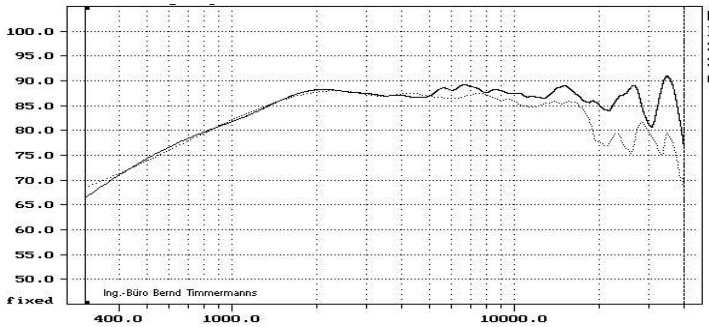

## C13-6



- 1" CERAMIC DOME TWEETER
- High efficiency version
- 4mm Underhung Neodymium magnet
- Heavy zinc frontplate
- Ferrofluid - reduced
- Flange 82 x 82mm
- Cut-out 64 x 64mm
- Depth 56mm

Znom	6	ohm	Sd	6.1	cm <sup>2</sup>
Re	-	ohm	BL	-	N/A
Le@1kHz	-	mH	Vas	-	ltrs
fs	1360	Hz	Xmax	-	mm peak
Qms	-		VC Ø	16.4	mm
Qes	-		Sensitivity		
Qts	-		2.83V / 1m	92	dB
Mms	-	g	Nom. Power	120	W
Cms	-	mm/N	Net weight	-	g

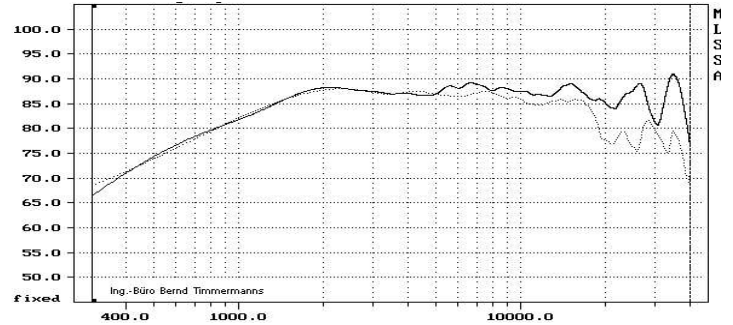

## C23-6



- 1.2" CERAMIC DOME TWEETER
- Wide bandwidth
- Response to @23kHz
- Very high resolution
- Very low resonance
- Ferrofluid loaded
- Flange 106 x 106mm
- Cut-out 89 x 89mm
- Depth 67mm

Znom	6	ohm	Sd	8.5	cm <sup>2</sup>
Re	6.1	ohm	BL	-	N/A
Le@1kHz	0.04	mH	Vas	-	ltrs
fs	350	Hz	Xmax	-	mm peak
Qms	-		VC Ø	19.4	mm
Qes	-		Sensitivity		
Qts	-		1W / 1m	89.5	dB
Mms	.4	g	Nom. Power	100	W
Cms	-	mm/N	Net weight	980	g

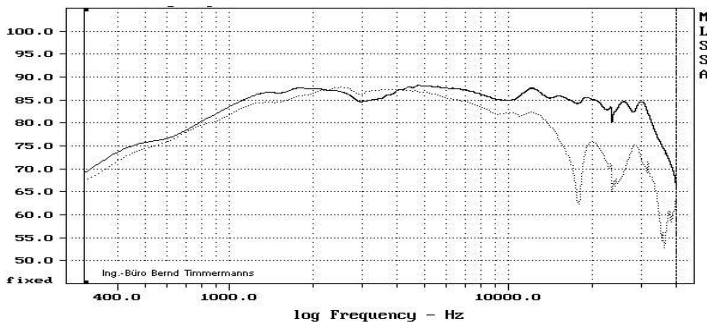

## C24-6



- 1.2" CERAMIC DOME TWEETER
- 6mm Underhung Neodymium magnet
- High efficiency version
- Very high resolution
- Ferrofluid loaded
- Flange 82 x 82mm
- Cut-out 64 x 64mm
- Depth 56mm

Znom	6	ohm	Sd	8.5	cm <sup>2</sup>
Re	-	ohm	BL	-	N/A
Le@1kHz	-	mH	Vas	-	ltrs
fs	835	Hz	Xmax	-	mm peak
Qms	-		VC Ø	19.4	mm
Qes	-		Sensitivity		
Qts	-		2.83V / 1m	92	dB
Mms	-	g	Nom. Power	100	W
Cms	-	mm/N	Net weight	-	g

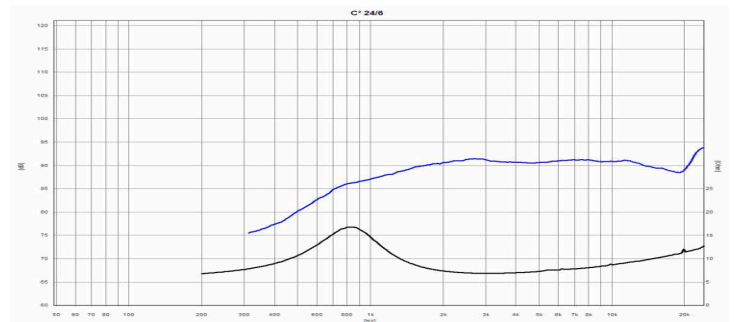



## C44-8



- 2" CERAMIC DOME MIDRANGE
- Response to @12kHz
- Flat on- and off- axis response from 400 Hz
- Very high resolution
- Ferrofluid loaded
- Flange 106x106mm
- Cut-out 89 x 89mm
- Depth 67mm

Znom	8 ohm	Sd	.02 cm <sup>2</sup>
Re	8.2 ohm	BL	3.47 N/A
Le@1kHz	24.6 mH	Vas	.11 ltrs
fs	390 Hz	Xmax	0.8 mm peak
Qms	1.19	VC Ø	30.4 mm
Qes	2.2	Sensitivity	
Qts	.77	1W / 1m	88.5 dB
Mms	1.3 g	Nom. Power	130 W
Cms	0.13 mm/N	Net weight	680 g

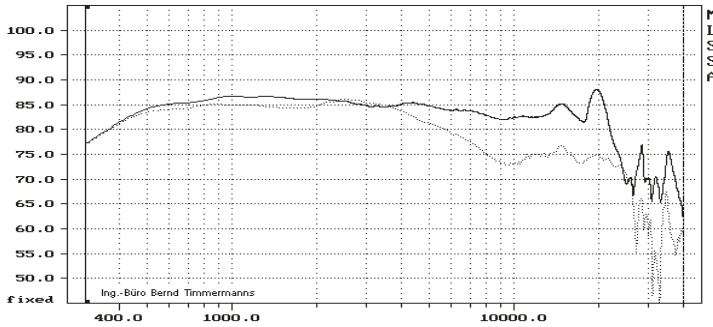

## C79-6



- 3" CERAMIC DOME MIDRANGE
- Good dispersion up to 5 kHz
- Very high resolution
- Requires 1.5 to 4 liter sealed chamber
- Flange 130x130mm
- Cut-out 116x116mm
- Depth 75mm

Znom	6 ohm	Sd	75.5 cm <sup>2</sup>
Re	5.8 ohm	BL	4.96 N/A
Le@1kHz	.12 mH	Vas	3.1 ltrs
fs	96 Hz	Xmax	2.6 mm peak
Qms	.96	VC Ø	37.7 mm
Qes	1.07	Sensitivity	
Qts	.51	1W / 1m	88.5 dB
Mms	7.2 g	Nom. Power	120 W
Cms	.39 mm/N	Net weight	1800 g

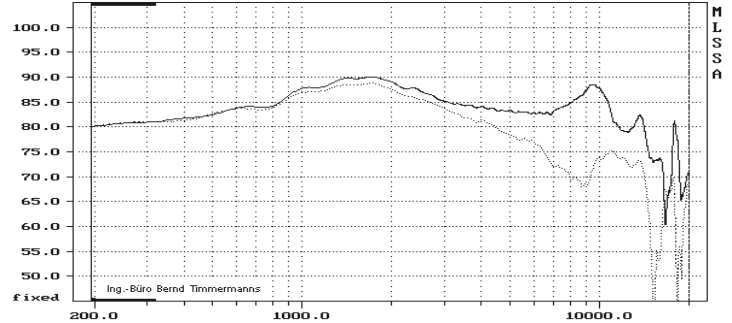

## C90-T6



- 6.5" CERAMIC MID
- High efficiency
- Titanium VC former
- Neodymium magnet
- Underhung voice coil
- Double roll surround
- Range 120Hz to 6kHz
- Flange 173mm round
- Cut-out 152mm
- Depth 90mm

Znom	6 ohm	Sd	145 cm <sup>2</sup>
Re	6.5 ohm	BL	11.7 N/A
Le@1kHz	- mH	Vas	8.8 ltrs
fs	73 Hz	Xmax	- mm peak
Qms	6.54	VC Ø	55 mm
Qes	.32	Sensitivity	
Qts	.30	2.83V / 1m	93.2 dB
Mms	15.75 g	Nom. Power	120 W
Cms	.3 mm/N	Net weight	1800 g

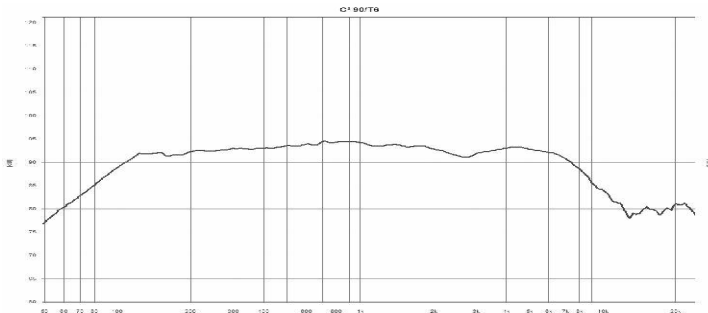

## C89-T6



- 5" CERAMIC BASS-MIDRANGE
- Good dispersion up to 5 kHz
- Very high resolution
- Rubber surround
- Titanium VC former
- Flange 130x130mm
- Cut-out 116x116mm
- Depth 75mm

Znom	6 ohm	Sd	83.3 cm <sup>2</sup>
Re	5.9 ohm	BL	7.1 N/A
Le@1kHz	0.4 mH	Vas	23.5 ltrs
fs	33.6 Hz	Xmax	3.1 mm peak
Qms	3.29	VC Ø	37.7 mm
Qes	.23	Sensitivity	
Qts	.215	1W / 1m	89.2 dB
Mms	9.3 g	Nom. Power	100 W
Cms	2.42 mm/N	Net weight	1800 g

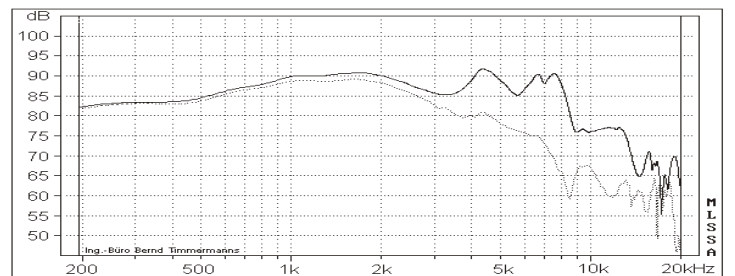



## C82-T8



- 5" CERAMIC BASS-MIDRANGE
- Good response up to 5 kHz
- Very high resolution
- Rubber surround
- Titanium VC former
- Flange 152mm
- Cut-out 122mm

Znom	8 ohm	Sd	76.0 cm <sup>2</sup>
Re	7.6 ohm	BL	7.23 N/A
Le@1kHz	0.93 mH	Vas	17.9 ltrs
fs	35.6 Hz	Xmax	- mm peak
Qms	5.82	VC Ø	25 mm
Qes	.27	Sensitivity	
Qts	.26	1W / 1m	86.7 dB
Mms	9.0 g	Nom. Power	130 W
Cms	2.22 mm/N	Net weight	1800 g

## C92-6



- 7" CERAMIC BASS-MIDRANGE
- Good dispersion up to 4 kHz
- Very high resolution
- Rubber surround
- Aluminum VC former
- Flange 180mm
- Cut-out 146mm
- Depth 87mm

Znom	8 ohm	Sd	133 cm <sup>2</sup>
Re	6.1 ohm	BL	5.1 N/A
Le@1kHz	0.4 mH	Vas	54.8 ltrs
fs	29 Hz	Xmax	4.0 mm peak
Qms	1.44	VC Ø	39 mm
Qes	.59	Sensitivity	
Qts	.42	1W / 1m	86 dB
Mms	13.8 g	Nom. Power	130 W
Cms	2.18 mm/N	Net weight	2450 g

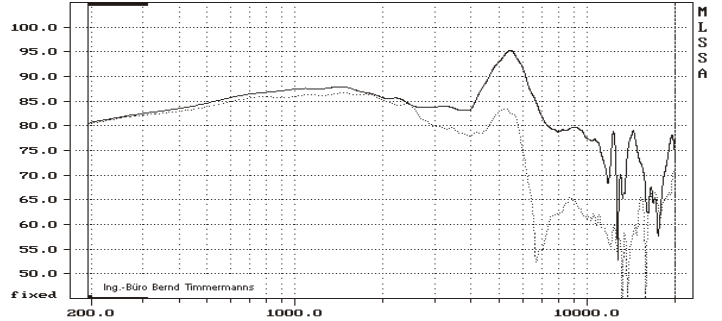
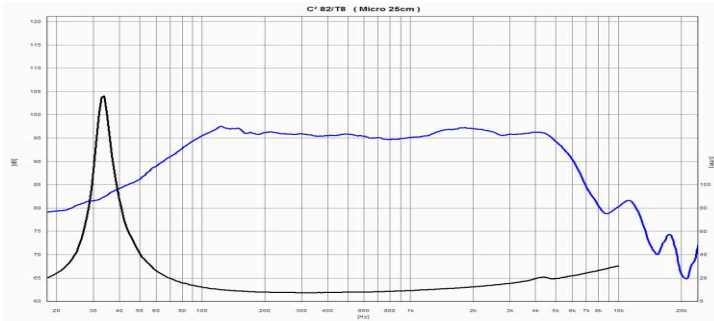

## C95-T6



- 7" CERAMIC BASS-MIDRANGE
- Good dispersion up to 3 kHz
- Very high resolution
- Rubber surround
- Titanium VC former
- Flange 180mm
- Cut-out 146mm
- Depth 108mm

Znom	6 ohm	Sd	133 cm <sup>2</sup>
Re	5.9 ohm	BL	8.32 N/A
Le@1kHz	0.73 mH	Vas	34.2 ltrs
fs	32 Hz	Xmax	5.0 mm peak
Qms	4.0	VC Ø	38 mm
Qes	.30	Sensitivity	
Qts	.279	1W / 1m	89.1 dB
Mms	13.8 g	Nom. Power	130 W
Cms	1.36 mm/N	Net weight	2450 g

## C220-T6



- 8" CERAMIC WOOFER
- Low resonance
- Suitable as subwoofer
- High excursion
- Rubber surround
- Titanium VC former
- Flange 222mm
- Cut-out 188mm
- Depth 120mm

Znom	6 ohm	Sd	233 cm <sup>2</sup>
Re	5.9 ohm	BL	9.1 N/A
Le@1kHz	0.61 mH	Vas	144 ltrs
fs	20.4 Hz	Xmax	5.2 mm peak
Qms	4.49	VC Ø	38 mm
Qes	0.29	Sensitivity	
Qts	0.27	1W / 1m	89.6 dB
Mms	31.9 g	Nom. Power	150 W
Cms	1.91 mm/N	Net weight	2950 g

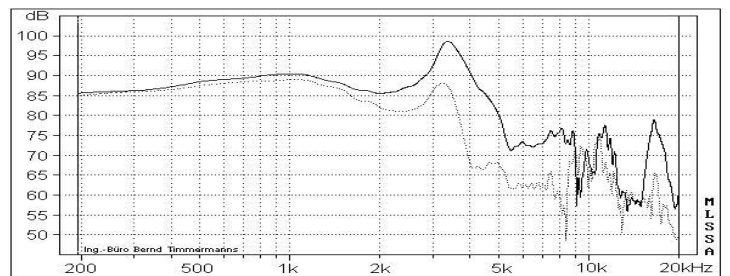
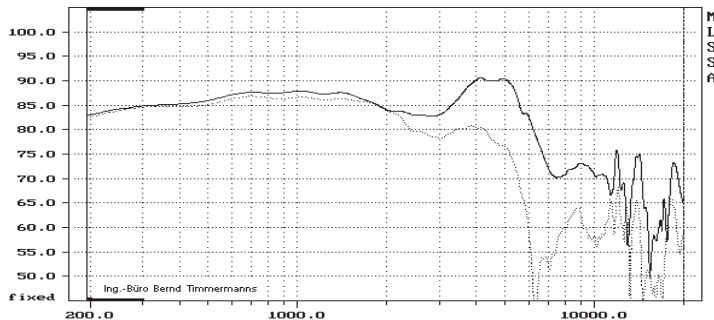



Model	Size Description	Ω	Fs Hz	Qts	Vas Ltrs	Xmax mm	Power Watts	dB	Cost Each
<p>*** Audax no longer produces speakers for distribution. We have good quantities on the items listed below. Many other Audax speakers are available from our website shopping cart at <a href="http://www.madisound.com">www.madisound.com</a>. AAC of France has started to produce some of the Audax parts. AAC was a supplier for Audax and purchased the parts and equipment to continue some of the Audax line. ***</p>									
Soft and Hard dome tweeters									
TW010E1	10mm polymer dome, 60mm x 60mm flange, shallow, 6kHz +	8	3000	-	-	0.25	25	90	\$5.60
TW010F1	10mm polymer dome, 74mm round flange	8	3000	-	-	0.25	25	90	\$5.15
TW025A0	25mm textile dome, 100mm round flange (3.93"), made by AAC	8	1090	-	-	0.65	55	90	\$21.25
TW025A2	25mm textile dome, 100mm round flange, 4 ohm, by AAC	4	1090	-	-	-	55	92	\$21.25
TW034X0	34mm textile dome, 132mm flange, made by AAC of France	8	800	-	-	0.25	70	93	\$47.20
Reference Series Carbon Fiber Cone Driver - Cast Frame, Rubber Surround									
HM100C0	4" Carbon Fiber mid/bass, made by AAC of France	8	54	.21	6.4	1.8	40	89	\$69.60
Polymer Chassis Woofers									
AP130Z0	Shielded 5.25" Aerogel cone, response 99S/60V to 2.5kHz	6	57.6	0.41	10.9	2.5	40	87.4	\$31.95
AP170Z0	Shielded 6.5" Aerogel cone, response 90S/55V to 2.5kHz	6	48.5	0.38	24.7	3	60	89.3	\$35.10
Professional Speaker									
PR170M0	6.5" Paper Cone midrange, 100dB, made by AAC of France	8	117	0.51	5.5	0.5	100	100	\$69.50
<h2>Audax Kits Designed by Joseph D'Appolito</h2> <p>Complete kit instructions available on our web site: <a href="http://www.madisound.com">www.madisound.com</a>.</p>									
Audax Center Channel - Each	Designed by Joseph D'Appolito, this kit consists of the following shielded Audax drivers: (2x) AP170Z0 Aerogel 6.5" woofers, AP130Z0 Aerogel 5" midbass and TM025F1 1" textile dome tweeter. (Without cabinets \$180 / each)								\$330.00 Each
Audax Fronts Pair	Designed by Joseph D'Appolito, this kit consists of the following shielded Audax drivers: (2x) AP170Z0 Aerogel 6.5" woofers, TM025F1 1" textile dome tweeter. (Without cabinets \$260 / pair)								\$560.00 Pair
Audax Rears Pair	Designed by Joseph D'Appolito, this kit consists of the following shielded Audax drivers: AP170Z0 Aerogel 6.5" woofer, TM025F1 1" textile dome tweeter. (Without cabinets \$170 / pair)								\$350.00 Pair



**Audax Front Channel Kit**

**\$560.00 a pair with Cabinets**

**\$260.00 a pair without cabinets**

**20 1/2" tall x 9.5" wide x 14 5/8" deep**



**Audax Center Channel Kit**

**\$330.00 each with Cabinet**

**\$180.00 each without cabinet**

**11" tall x 24" wide x 13 7/8" deep**

## Audax Home Theater Kits

by

Joseph D'Appolito



**Audax Rear Channel Kit**

**\$350.00 a pair with Cabinets**

**\$170.00 a pair without cabinets**

**12 1/2" T x 9" W x 9 7/8" D**



## TW010E1



- 10mm Polymer Dome Tweeter
- Formerless VC
- Ferrofluid cooled
- Light and compact
- Suitable for auto or home use
- Flange 60x60mm
- Cut-out 48mm
- Depth 14.4mm

Znom	8 ohm	Sd	.03 cm <sup>2</sup>
Re	5.5 ohm	BL	1.3 N/A
Le@1kHz	.03 mH	Vas	- ltrs
fs	3000 Hz	Xmax	0.25 mm peak
Qms	-	VC Ø	10 mm
Qes	-	Sensitivity	
Qts	-	1W / 1m	90 dB
Mms	.11 g	Nom. Power DIN	25 W
Cms	- mm/N	Net weight	0.05 kg

## TW010F1



- 10mm Polymer Dome Tweeter
- Formerless VC
- Ferrofluid cooled
- 1st order above 6K
- Exceptional transient response
- Flange 74mm
- Cut-out 48mm
- Depth 14.4mm

Znom	8 ohm	Sd	.03 cm <sup>2</sup>
Re	5.5 ohm	BL	1.3 N/A
Le@1kHz	.03 mH	Vas	- ltrs
fs	3000 Hz	Xmax	0.25 mm peak
Qms	-	VC Ø	10 mm
Qes	-	Sensitivity	
Qts	-	1W / 1m	90 dB
Mms	.11 g	Nom. Power DIN	25 W
Cms	- mm/N	Net weight	0.05 kg

Sensitivity Mag - dB SPL/watt (8.0 ohm load) (0.16 oct)(eq)

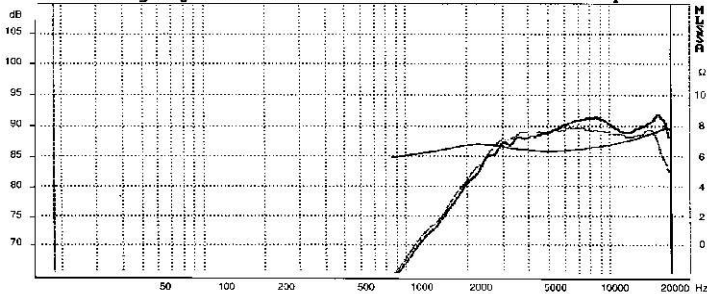

Sensitivity Mag - dB SPL/watt (8.0 ohm load) (0.16 oct)(eq)

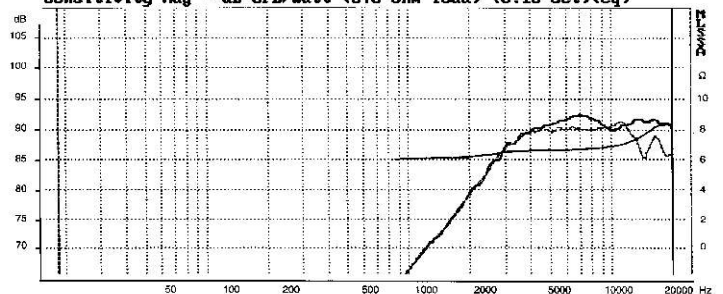

## TW025A0



- 25mm Textile Dome
- 100mm Round Flange
- 8 ohms
- Replaceable voice coil
- Aluminum faceplate
- Flange 100mm
- Cut-out 75mm
- Depth 23.5mm

Znom	8 ohm	Sd	4.91 cm <sup>2</sup>
Re	5.8 ohm	BL	1 N/A
Le@1kHz	.03 mH	Vas	- ltrs
fs	1090 Hz	Xmax	0.65 mm peak
Qms	4.21	VC Ø	25 mm
Qes	1.3	Sensitivity	
Qts	1	1W / 1m	90 dB
Mms	- g	Nom. Power DIN	55 W
Cms	- mm/N	Net weight	460 g

## TW034X0



- 34mm Textile Dome Tweeter
- Extended frequency response
- Replaceable VC
- Solid aluminum faceplate
- Flange 132mm
- Cut-out 106mm
- Depth 29mm

Znom	8 ohm	Sd	10.8 cm <sup>2</sup>
Re	5.3 ohm	BL	3.5 N/A
Le@1kHz	- mH	Vas	- ltrs
fs	800 Hz	Xmax	0.25 mm peak
Qms	-	VC Ø	34 mm
Qes	-	Sensitivity	
Qts	-	1W / 1m	93 dB
Mms	0.5 g	Nom. Power DIN	70 W
Cms	- mm/N	Net weight	1180 g

Sensitivity Mag - dB SPL/watt (0.10 oct)(eq)

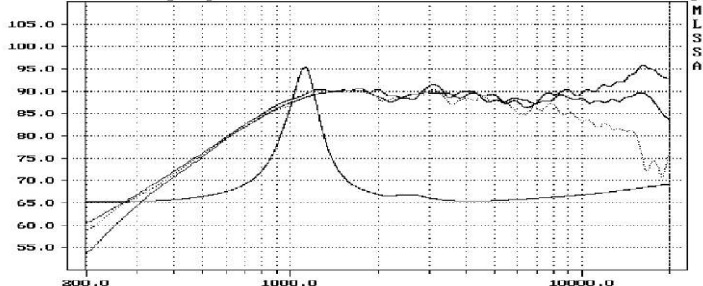

Sensitivity Mag - dB SPL/watt (0.10 oct)(eq)

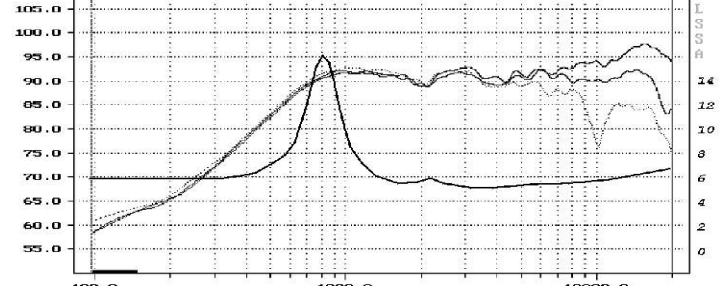

## HM100C0



- 4" Carbon Fiber Cone Mid-bass
- Diecast basket
- Rubber surround
- Kapton VC former
- Venting under spider
- Gold plated terminals
- Flange 110mm square
- Cut-out 94mm
- Depth 57mm

Znom	8 ohm	Sd	- cm <sup>2</sup>
Re	6.4 ohm	BL	6.96 N/A
Le@1kHz	.11 mH	Vas	6.4 ltrs
fs	54 Hz	Xmax	1.8 mm peak
Qms	3.27	VC Ø	25 mm
Qes	0.22	Sensitivity	
Qts	0.21	1W / 1m	89 dB
Mms	5.1 g	Nom. Power DIN	40 W
Cms	- mm/N	Net weight	.93 kg

## PR170M0 (100dB)



- Professional 6.5" Paper Cone Midrange
- Diecast basket
- Flat Foam surround
- Kapton VC former
- Edgewound 40mm VC
- Gold plated terminals
- Flange 190mm square
- Cut-out 145mm
- Depth 76mm

Znom	8 ohm	Sd	139 cm <sup>2</sup>
Re	6.2 ohm	BL	8.24 N/A
Le@1kHz	.73 mH	Vas	5.5 ltrs
fs	117 Hz	Xmax	0.5 mm peak
Qms	3.16	VC Ø	40 mm
Qes	0.61	Sensitivity	
Qts	0.51	1W / 1m	100 dB
Mms	9.17 g	Nom. Power DIN	100 W
Cms	- mm/N	Net weight	2.5 kg

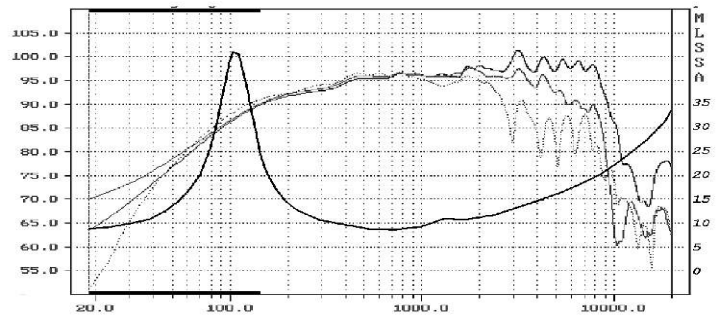
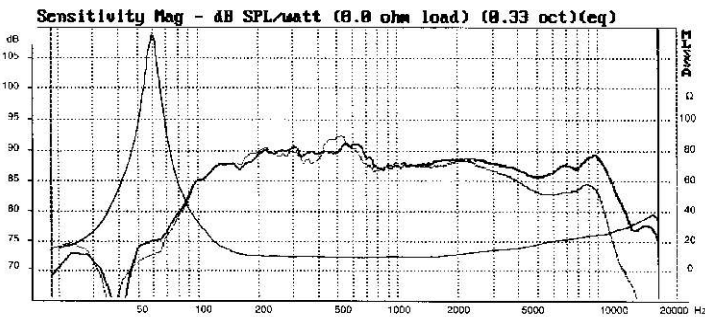

## AP130Z0



- 5.25" Shielded Aerogel Cone Bass Midrange
- Suitable for A/V
- Non-resonant polymer chassis
- Rubber surround
- Built in mounting ring
- Flange 143mm
- Cut-out 112mm
- Depth 66.5mm

Znom	6 ohm	Sd	cm <sup>2</sup>
Re	5.7 ohm	BL	4.72 N/A
Le@1kHz	.4 mH	Vas	10.85 ltrs
fs	57.6 Hz	Xmax	0.35 mm peak
Qms	1.48	VC Ø	25 mm
Qes	.57	Sensitivity	
Qts	.41	1W / 1m	87.4 dB
Mms	6.86 g	Nom. Power DIN	40 W
Cms	1.11 mm/N	Net weight	.9 kg

## AP170Z0



- 6.5" Shielded Aerogel Cone Woofer
- Suitable for A/V
- Non-resonant polymer chassis
- Rubber surround
- Built in mounting ring
- Flange 173mm
- Cut-out 144mm
- Depth 79.5mm

Znom	6 ohm	Sd	132.7 cm <sup>2</sup>
Re	5.3 ohm	BL	5.76 N/A
Le@1kHz	.74 mH	Vas	24.65 ltrs
fs	48.5 Hz	Xmax	3 mm peak
Qms	1.61	VC Ø	30 mm
Qes	0.5	Sensitivity	
Qts	0.38	1W / 1m	89.3 dB
Mms	10.82 g	Nom. Power DIN	60 W
Cms	9.9 mm/N	Net weight	1.4 kg

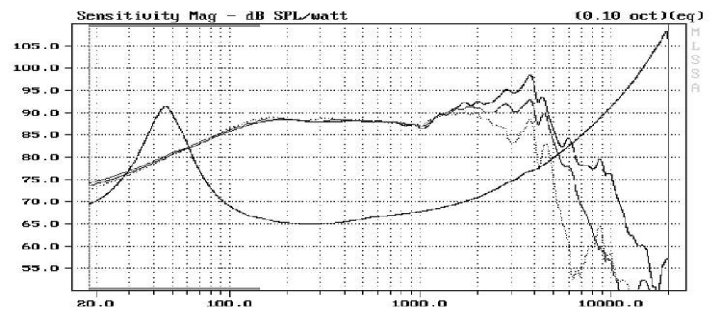
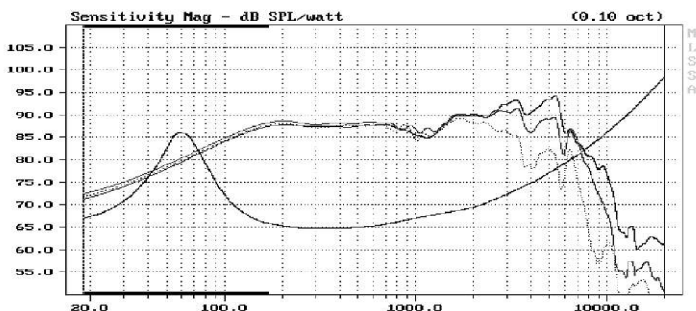





## IWS-Micro In-wall Speaker

- 1.25" Micro In-wall
- Designed for installation in single gang box
- 20W RMS power handling
- Frequency range 150Hz - 20kHz  $\pm$  6dB
- Capable of high SPL for such a small speaker
- 8 ohm impedance
- Inherently Shielded
- 33mm voice coil  $\varnothing$
- 84 dB
- (single gang box not included)



**Price Each \$43.00**

The IWS-Micro is a Sound Contractors dream. This little speaker has a big speaker output. The 3mm peak x-max allows for a lot of cone travel. This speaker has no application boundaries and challenges the imagination for new uses. Here are some ideas we've thought of:

- Computer surround sound
- Information applications in museums, libraries, etc.
- Theme park rides
- Bathrooms
- Ambient sound in waiting rooms and offices
- Computer monitors
- Home theater arrays
- Aircraft



## NSW1-205-8A 1" Extended Range

### Specifications:

Fs	220	Hz
Nominal Imp.	8	ohms
Power (RMS)	5	W
Re	6.3	ohms
Sens. 1W/1m	78	dB
X-max peak	1.5	mm
Qms	2.1	
Qes	1.1	
Qts	0.7	
Vas	0.04	ltrs
BL	1.9	TM
Mms	0.50	gr
Cms	1155	$\mu$ M/N
Sd	5.31	cm <sup>2</sup>
Net weight	52.3	g
Max Exc. p2p	6	mm
VC diameter	20	mm

### Features:

- Frequency 220 to 25kHz
- Titanium dome
- Underhung voice coil
- NRT neodymium magnet system
- Inherently shielded
- Foam surround
- Frame: 39mm square
- Overall Depth: 22mm



**Price Each \$12.20**

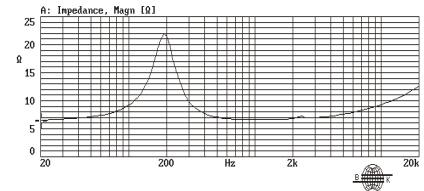
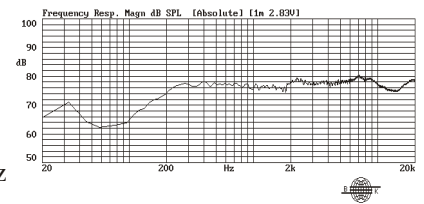

## NSW2-326-8A 2" Extended Range

### Specifications:

Fs	250	Hz
Nominal Imp.	8	ohms
Power (RMS)	15	W
Re	6.4	ohms
Sens. 1W/1m	84	dB
X-max peak	3	mm
Qms	4.72	
Qes	0.80	
Qts	0.68	
Vas	0.1	ltrs
BL	3.5	TM
Mms	1.04	gr
Cms	390	$\mu$ M/N
Sd	13.2	cm <sup>2</sup>
Net weight	113	g
Max Exc. p2p	10	mm
VC diameter	33	mm

### Features:

- Frequency 250 to 15kHz
- Titanium dome
- Underhung voice coil
- NRT neodymium magnet system
- Inherently shielded
- Foam surround
- Frame: 49mm square
- Overall Depth: 29.4mm



**Price Each \$16.00**

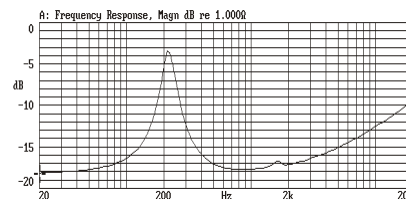
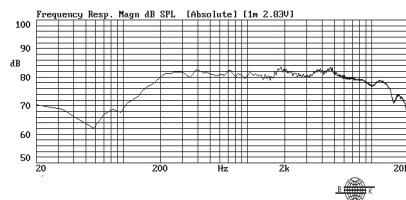

## NS3-193-4A/8A & 4B/8B 3" Extended Range

### Specifications:

Fs	80	Hz
Nominal Imp.	8	ohms
Power (RMS)	20	W
Re	7.6	ohms
Sens. 1W/1m	80	dB
X-max peak	3.1	mm
Qms	8.0	
Qes	0.73	
Qts	0.67	
Vas	1.25	ltrs
BL	4.7	TM
Mms	4.3	gr
Cms	920	$\mu$ M/N
Sd	31	cm <sup>2</sup>
Net weight	216	g
Max Exc. p2p	20	mm
VC diameter	19.3	mm

### Features:

- Frequency 80 to 15kHz
- Aluminum dome
- Underhung voice coil
- NRT neodymium magnet system
- Inherently shielded
- Rubber surround
- Frame: 88.5mm
- Depth: 55mm



Now available in 4 or 8 ohm, silver or black cones.

**Price Each \$19.50**

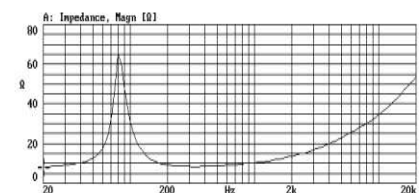
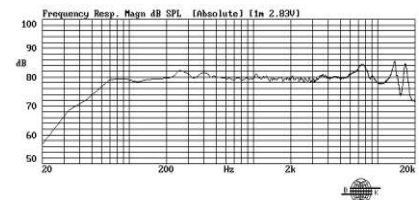

Recommended Enclosure for F3 of 85Hz:  
2 to 3 liters sealed and stuffed



## NS4-255-4D1/8D1 4" Extended Range

### Specifications:

	4Ω	8Ω
Fs	57	62 Hz
Power (RMS)	20	20 W
Re	3.6	6.17 ohms
Sens. 1W/1m	84	84 dB
X-max peak	5.5	5.5 mm
Qms	6.98	7.79
Qes	0.41	0.47
Qts	0.39	0.44
Vas	3.78	3.18 ltrs
BL	4.82	6.12 TM
Mms	7.42	7.29 gr
Cms	1053	893 μM/N
Sd	50.27	50.27 cm <sup>2</sup>
Net weight	384	384 g
VC diameter	25.5	25.5 mm

### Features:

- Frequency 60 to 6kHz
- Low distortion
- Aluminum cone
- Underhung voice coil
- NRT neodymium magnet system
- Inherently shielded
- Rubber surround
- Frame: 105mm
- Depth: 66mm



**Price Each \$34.00**

Please refer to our web site for impedance curves and box alignments.

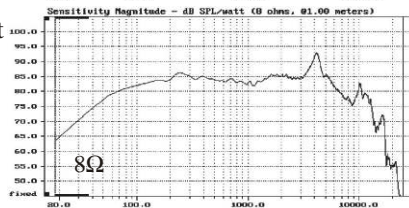
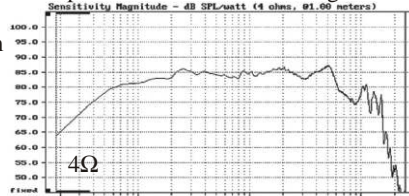

## NRT18-8 18" Pro Sound Woofer

### Specifications:

Fs	25	Hz
Nominal Imp.	8	ohms
Power (RMS)	800	W
Re	5.6	ohms
Sens. 1W/1m	96	dB
X-max peak	18	mm
Qms	4.40	
Qes	0.28	
Qts	0.26	
Vas	475	ltrs
BL	24.5	TM
Mms	186	gr
Cms	218	μM/N
Sd	1240	cm <sup>2</sup>
Net weight	13.5	kg
VC diameter	99.1	mm

### Features:

- Frequency 25 to 2kHz
- Low distortion
- Paper/fiberglass/epoxy cone material
- Edgewound aluminum ribbon voice coil
- NRT neodymium magnet
- Inherently shielded
- Polyester Weave surround



**Price Each \$912.00**

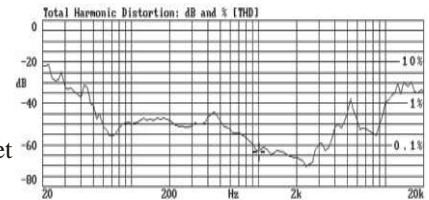
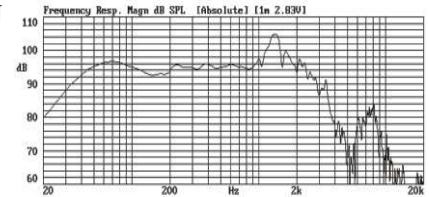

F3 of 52Hz in 4.5cf vented box with two 4" Ø vents x 9.5" long, some stuffing



## NSF8-495-8B 8" Shallow Woofer

### Specifications:

Fs	41.6	Hz
Nominal Imp.	8	ohms
Power (RMS)	150	W
Re	6.57	ohms
Sens. 1W/1m	86	dB
X-max peak	6	mm
Qms	5.09	
Qes	0.52	
Qts	0.47	
Vas	16.34	ltrs
BL	12.6	TM
Mms	48.45	gr
Cms	302	μM/N
Sd	196	cm <sup>2</sup>
VC diameter	50	mm

### Features:

- Frequency 35 to 350Hz
- Shallow depth
- Good for autosound or in-wall
- Underhung voice coil
- NRT neodymium magnet system
- Inherently shielded
- Low bass in a small enclosure

**Price Each \$117.40**



F3 of 60Hz in 13 liters sealed box or F3 of 35Hz in 20 liters vented; 2" x 7" vent.



## AST-2B-4 Pro Bass Shaker

Aurasound Pro Bass Shaker  
50Watt  
4 ohm  
6" in diameter, 2 1/4" tall  
Fs 40Hz  
**Price Each \$39.00**

Want to feel your music? The Bass Shaker products allow you to experience every thump, thrust and shake...the way bass sound was originally intended. Aura's patented technology preserves the sound pressure levels so there's no distortion while enhancing the bass energy delivered from your stereo. We're taking surround sound to another level....

To add bass shakers to your home theater system, they need to be powered by an amplifier and receive the same signal as your powered subwoofer. Bass shakers should be rigidly mounted to the bottom of your seat, whether it your car seat or your sofa.



AST-3B-4 Pro Bass Shaker Automotive System with 100 Watt Class D amplifier and remote volume control. Speaker wire, screws, RCA cable and instructions are included in the system  
**Price per set: \$224.00**





### NS525-326-4A/8A 5.25" Woofer



### NS65-385-4A/8A 6.5" Woofer

#### Specifications:

	4Ω	8Ω
Fs	50	48 Hz
Power (RMS)	-	W
Re	2.9	6.2 ohm
Sens. 1W/1m	83	83 dB
X-max peak	7	7 mm
Qms	11.6	9.7
Qes	0.43	0.47
Qts	0.41	0.45
Vas	6.7	8.0 ltrs
BL	6.2	8.0 TM
Mms	18.1	16.1 gr
Cms	565	679 μM/N
Sd	91.6	91.6 cm <sup>2</sup>



**Price Each \$69.80**

Please refer to our web site for impedance curves and box alignments.

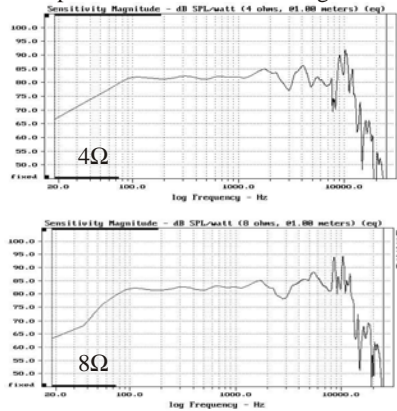

- Net weight 1.1kg
- VC diameter 32.6 mm
- Frequency Fo to 1.5kHz
- Aluminum Cone - black
- Underhung voice coil
- NRT neodymium magnet
- Inherently shielded
- Rubber surround
- Frame: 139mm sq. part
- Frame: 156.5mm rd. part
- Cut out: 122.5mm
- Flange thickness 6mm
- Depth: 91mm

#### Specifications:

	4Ω	8Ω
Fs	41	41 Hz
Power (RMS)	-	W
Re	3.0	6.2 ohm
Sens. 1W/1m	84	84 dB
X-max peak	9	9 mm
Qms	12.2	11.1
Qes	0.30	0.36
Qts	0.30	0.35
Vas	12.1	12.5 ltrs
BL	8.71	11.2 TM
Mms	30.5	28.7 gr
Cms	505	520 μM/N
Sd	130.7	130.7 cm <sup>2</sup>



**Price Each \$97.70**

Please refer to our web site for impedance curves and box alignments.

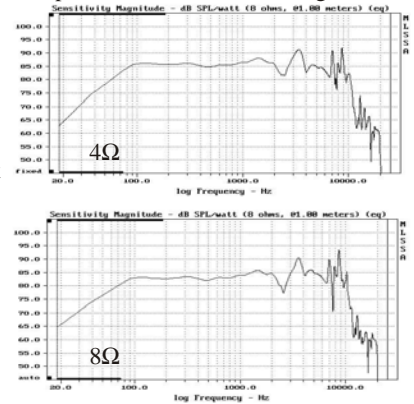

- Net weight 1.7 kg
- VC diameter 38.5 mm
- Frequency Fo to 1.5kHz
- Aluminum Cone - black
- Underhung voice coil
- NRT neodymium magnet
- Inherently shielded
- Rubber surround
- Frame: 162.5mm sq. part
- Frame: 177.5mm rd. part
- Cut out: 145mm
- Flange thickness 6mm
- Depth: 98mm



### NS10-513-4A 10" Woofer



### NS12-513-4A 12" Woofer

#### Specifications:

Fs	29	Hz
Nominal Imp.	4	ohms
Power (RMS)	200	W
Re	3.04	ohms
Sens. 2.83V/1m	88	dB
X-max peak	10	mm
Qms	9.40	
Qes	0.35	
Qts	0.34	
Vas	53.6	ltrs
BL	12.2	TM
Mms	95.5	gr
Cms	318	μM/N
Sd	346	cm <sup>2</sup>



**Price Each \$171.00**

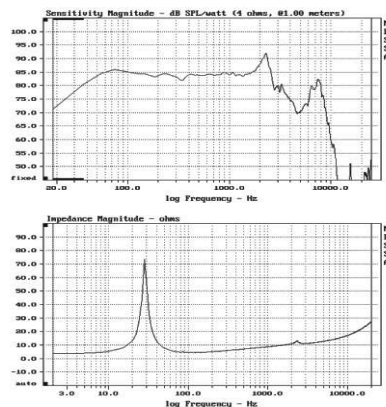

- Net weight 4.5 kg
- Max Exc. p2p 44 mm
- VC diameter 51.3 mm
- Frequency Fo to 1.6kHz
- Aluminum Cone - black
- Underhung voice coil
- NRT neodymium magnet system
- Inherently shielded
- Rubber surround
- Frame: 261.2 mm
- Cut out: 225.7 mm
- Depth: 157.7 mm

Recommended Enclosure for F3 of 30Hz:  
1.6 cubic feet with 3" Ø vent by 12" long

#### Specifications:

Fs	23	Hz
Nominal Imp.	4	ohms
Power (RMS)	200	W
Re	2.86	ohms
Sens. 2.83V/1m	89.5	dB
X-max peak	10	mm
Qms	9.10	
Qes	0.39	
Qts	0.37	
Vas	127	ltrs
BL	12	TM
Mms	137	gr
Cms	356	μM/N
Sd	503	cm <sup>2</sup>



**Price Each \$182.00**

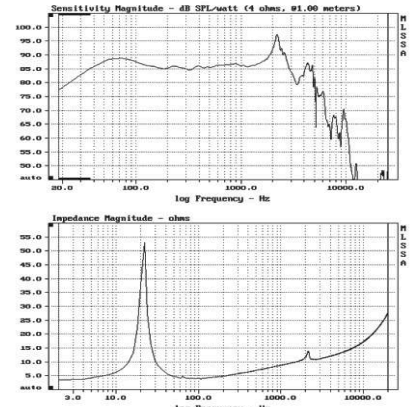

- Net weight 4.8 kg
- Max Exc. p2p 44 mm
- VC diameter 51.3 mm
- Frequency Fo to 1.4kHz
- Aluminum Cone - black
- Underhung voice coil
- NRT neodymium magnet system
- Inherently shielded
- Rubber surround
- Frame: 309.7 mm
- Cut out: 279.3 mm
- Depth: 158.9 mm

Recommended Enclosure for F3 of 28Hz:  
2.7 cubic feet with 3" Ø vent by 10" long



## NS10-794-4A 10" Subwoofer



## NS12-794-4A 12" Subwoofer

### Specifications:

Fs	32	Hz
Nominal Imp.	4	ohms
Power (RMS)	400	W
Re	3.6	ohms
Sens. 1W/1m	83	dB
X-max peak	18	mm
Qms	7.8	
Qes	0.42	
Qts	0.4	
Vas	33	ltrs
BL	13	TM
Mms	103	gr
Cms	236	$\mu\text{M/N}$
Sd	317	$\text{cm}^2$
Net weight	7.7	kg
Max Exc. p2p	60	mm
VC diameter	79.4	mm



**Price Each \$481.00**

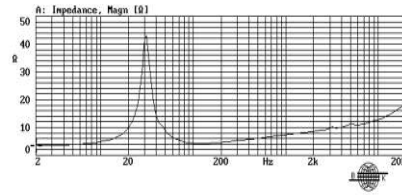
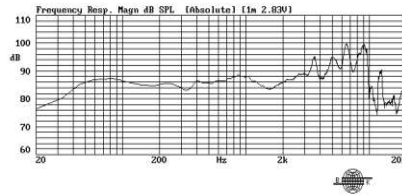

Recommended Enclosure for F3 of 30Hz:  
1.5 cubic feet with 3" Ø vent by 12" long

### Specifications:

Fs	27	Hz
Nominal Imp.	4	ohms
Power (RMS)	400	W
Re	3.5	ohms
Sens. 1W/1m	84	dB
X-max peak	18	mm
Qms	7.1	
Qes	0.45	
Qts	0.43	
Vas	78	ltrs
BL	14	TM
Mms	152	gr
Cms	233	$\mu\text{M/N}$
Sd	487	$\text{cm}^2$
Net weight	8.0	kg
Max Exc. p2p	60	mm
VC diameter	79.4	mm



**Price Each \$565.00**

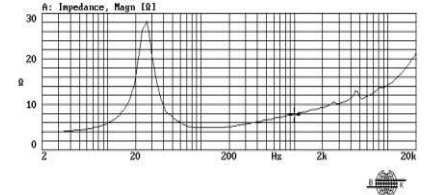
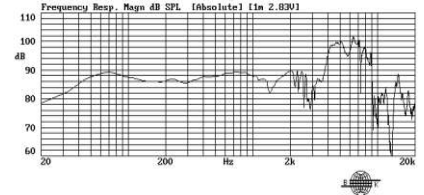

Recommended Enclosure for F3 of 25Hz:  
3.5 cubic feet with 4" Ø vent by 12" long



## NS15-992-4A 15" Subwoofer



## NS18-992-4A 18" Subwoofer

### Specifications:

Fs	20	Hz
Nominal Imp.	4	ohms
Power (RMS)	800	W
Re	3.3	ohms
Sens. 1W/1m	86	dB
X-max peak	25	mm
Qms	8.0	
Qes	0.4	
Qts	0.37	
Vas	169	ltrs
BL	18	TM
Mms	314	gr
Cms	206	$\mu\text{M/N}$
Sd	765	$\text{cm}^2$
Net weight	20.1	kg
Max Exc. p2p	75	mm
VC diameter	99.2	mm



**Price Each \$685.00**

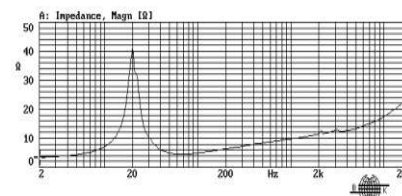
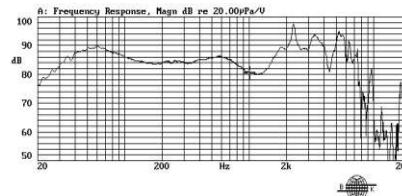

Recommended Enclosure for F3 of 22Hz:  
4.5 cubic feet with 4" Ø vent by 15" long

### Specifications:

Fs	20	Hz
Nominal Imp.	4	ohms
Power (RMS)	800	W
Re	3.1	ohms
Sens. 1W/1m	86	dB
X-max peak	25	mm
Qms	7.7	
Qes	0.5	
Qts	0.47	
Vas	322	ltrs
BL	17	TM
Mms	400	gr
Cms	170	$\mu\text{M/N}$
Sd	1164	$\text{cm}^2$
Net weight	19.7	kg
Max Exc. p2p	75	mm
VC diameter	99.2	mm



**Price Each \$882.00**

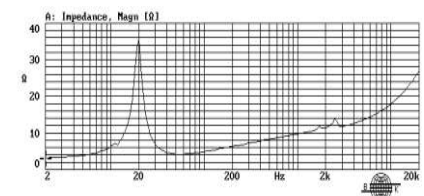
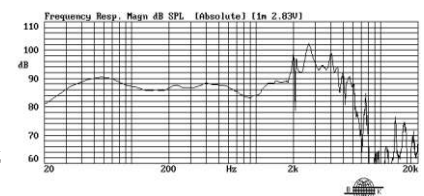

Recommended Enclosure for F3 of 35Hz:  
4.5 cubic feet sealed and stuffed

- Frequency Fo to 1.5kHz
- Aluminum Cone - black
- Underhung voice coil
- NRT neodymium magnet system
- Inherently shielded
- Rubber surround
- Frame: 268.2mm
- Cut out: 232.2mm
- Depth: 178.3mm

- Frequency Fo to 1.5kHz
- Aluminum Cone - black
- Underhung voice coil
- NRT neodymium magnet system
- Inherently shielded
- Rubber surround
- Frame: 317mm
- Cut out: 280mm
- Depth: 202mm

- Frequency Fo to 1.5kHz
- Aluminum Cone - black
- Underhung voice coil
- NRT neodymium magnet system
- Inherently shielded
- Rubber surround
- Frame: 477mm
- Cut out: 426.4mm
- Depth: 287.1mm





Unit	Description	$\Omega$	fs	dB	Watt	Price Each
ER-4	Air Motion Ribbon Tweeter - 1.5 to 30kHz	6	490	88	60	\$305.00
19 SD 1	3/4" Textile Dome Tweeter, dbl. magnet	8	1100	89	80	\$59.00
25 SD 1	1" Textile Dome Tweeter, dbl. magnet	8	1000	90	100	\$66.00
<b>All Eton midranges and woofers feature Kevlar/Nomex Hexacone cones.</b>						
4-300	4" Kevlar Midrange / Woofer	8	61	88	50	\$94.00
5-880	5" Kevlar Woofer	8	52	87	50	\$107.00
7-360	7" Kevlar Woofer	8	43	89	100	\$130.00
7-372	7" Long Throw Kevlar Woofer with heat pipe	8	32	88	80	\$160.00
7-375	7" Kevlar woofer with aluminum dust cap, low distortion	8	38	88	70	\$158.00
8-472	8" Long Throw Kevlar Woofer with heat pipe	8	24	88	90	\$199.00
8-800	8" Kevlar Woofer	8	36	89	120	\$153.00
11-581	11" Kevlar Woofer	8	21	91	150	\$306.00
12-680	12" Kevlar Woofer	8	26	91	200	\$439.00

### Eton Kits engineered by Eton in Germany

All kits include speakers, crossovers, all brass gold plated input terminals, black screws, port tubes and port tube trim rings, foam dampening pads, Acusta-Stuf (if called for) and Supra Classic internal speaker wire. Cabinet drawings are included. **Cabinets are not available at this time.** We recommend using Deflex panels behind the woofers and within the midrange chambers. Hovland MusiCaps can be used on the tweeter in all designs for an additional fee. Consider our tiptoes in finishing your speaker.

<b>Eton 7.3 Kit:</b> 2-way system using the 7-375 woofer and ER-4 tweeter. Small monitor design. Hovland MusiCaps on tweeter, add \$117.00 for the pair.	<b>\$940.00 pr</b>
<b>Eton 8.1 Kit:</b> 2-way system using 8-800 woofer and 25SD-1 tweeter. Floor standing.	<b>\$495.00 pr</b>
<b>Eton 8.2 Kit:</b> 3-way system using 8-800 woofer, 5-880 midrange and 19SD-1 tweeter. Floor standing.	<b>\$825.00 pr</b>
<b>Eton 11.2 Kit:</b> 3-way system using 11-581 woofer, 5-880 midrange and 19SD-1 tweeter. Floor standing.	<b>\$1059.00 pr</b>

### ETON 8.1 Kit

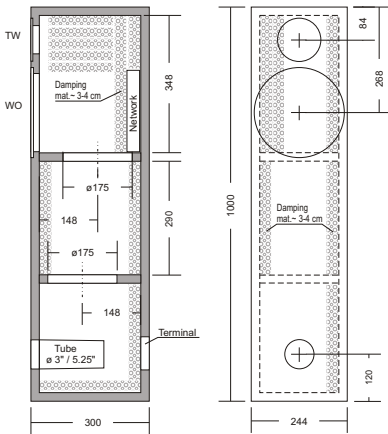

- 8" 2-Way Design
- Cabinets not available
- Fully assembled premium crossovers
- 8-800 woofer
- 25SD-1 tweeter
- All damping materials included
- 39.4" tall
- 11.8" deep
- 9.6" wide

### ETON 11.2 Kit

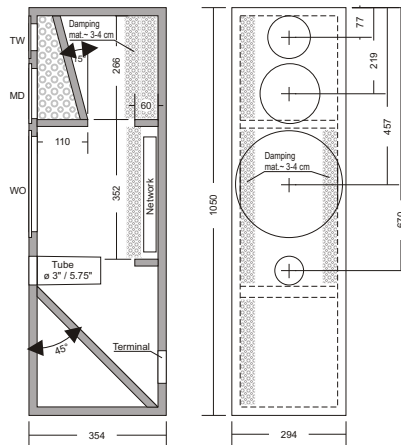

- 11" 3-Way Design
- Cabinets not available
- Fully assembled premium crossovers
- 11-581 woofer
- 5-880 midrange
- 19SD-1 tweeter
- 41.3" tall
- 13.9" deep
- 11.6" wide

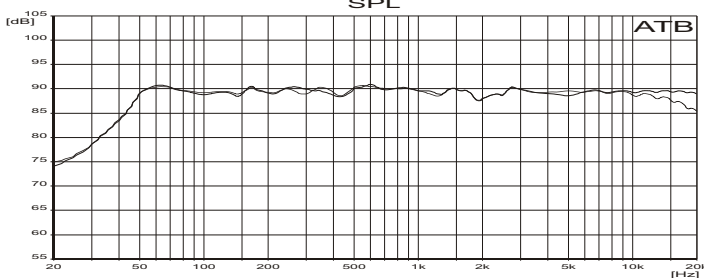

ETON - Model 8.1  
SPL 1 Watt / 1 m - 0°, 30°

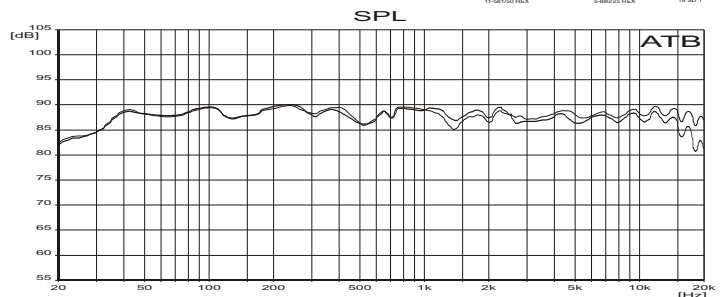

ETON - Model 11.2  
SPL 1 Watt / 1 m - 0°, 30°

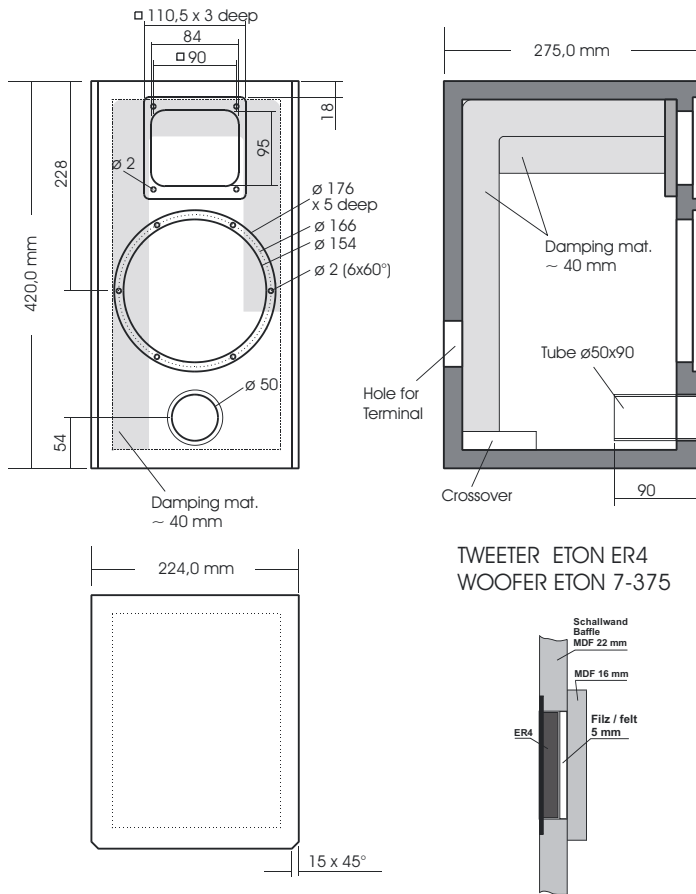

# ETON 7.3 Kit

- 7" 2-Way Design
- Cabinets not available
- Fully assembled premium crossovers
- 7-375 woofer
- ER-4 tweeter
- 16.5" tall
- 10.8" deep
- 8.8" wide

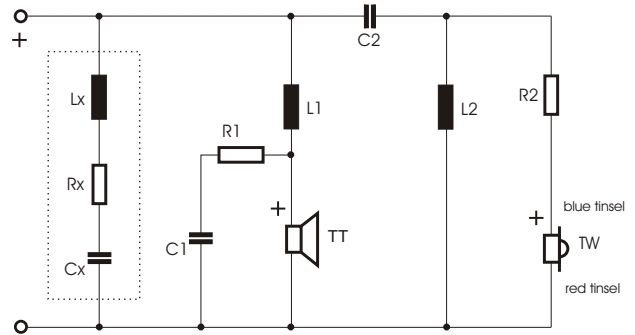

TWEETER ETON ER4  
WOOFER ETON 7-375

L1 = 2,2 mH / Copper Wire CUL ∅ 1,0 mm / air  
L2 = 0,56 mH / Copper Wire CUL ∅ 1,0 mm / air

C1 = 15 MF / bipolar-Capacitor / 50 Vac  
C2 = 15 MF / foil-capacitor (MKP)

R1 = 4,7 Ohm / 4 W  
R2 = 2,2 Ohm / 4 W - metaloxid

TT = ETON 7-375 / 32 HEX  
HT = ETON ER 4

Inductance Compensation - for Tube-Amps only  
Lx = 1,2 mH / Copper Wire CUL ∅ 1,0 mm  
Cx = 47 MF / bipolar-Capacitor / 50 Vac  
Rx = 12 Ohm / 4 W

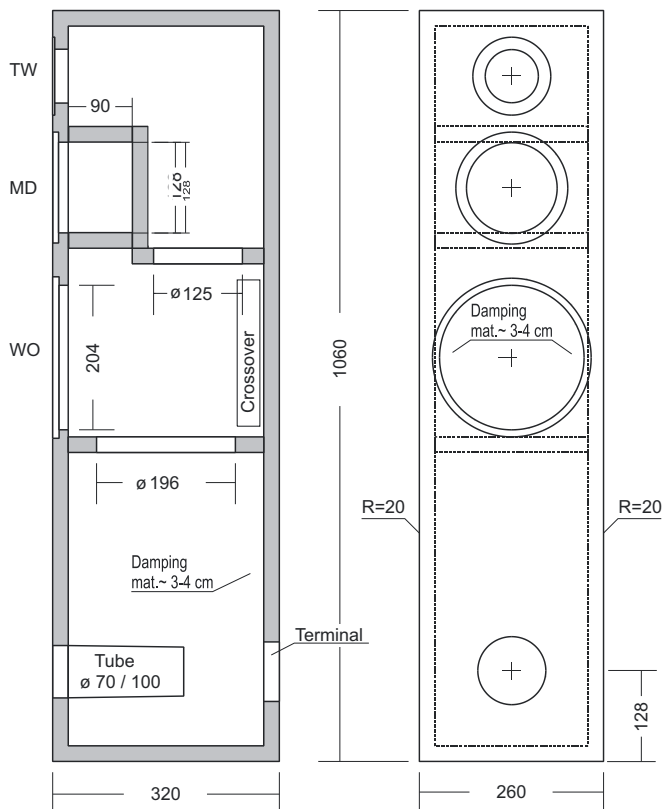

# ETON 8.2 Kit

- 8" 3-Way Design
- Cabinets not available
- Fully assembled premium crossovers
- 8-800 woofer
- 5-880 midrange
- 19SD-1 tweeter
- 41.75" tall
- 12.6" deep
- 10.25" wide

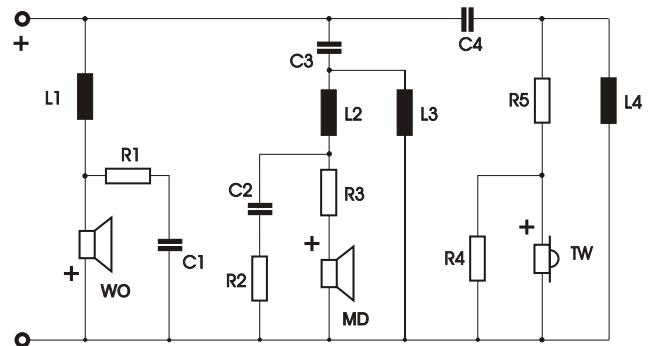

L1 = 4,7 mH / Copper Wire CUL ∅ 1,4 mm / air  
L2 = 0,68 mH / Copper Wire CUL ∅ 1,0 mm / air  
L3 = 5,6 mH / Copper Wire CUL ∅ 1,0 mm / air  
L4 = 0,33 mH / Copper Wire CUL ∅ 0,7 mm air

C1 = 150 MF / bipolar-capacitor / 50 Vac  
C2 = 6,8 MF / bipolar-Capacitor / 50 Vac  
C3 = 68 MF / bipolar-capacitor / 50 Vac  
C4 = 4,7 MF / foil-capacitor (MKP)

R1 = 1,5 Ohm / 4 W  
R2 = 5,6 Ohm / 4 W  
R3 = 0,75 Ohm / 10 W  
R4 = 15 Ohm / 4 W  
R5 = 2,7 Ohm / 4 W - metaloxid

WO = ETON 8-800/37 HEX / 8 Ohm  
MD = ETON 5-880/25 HEX / 8 Ohm  
TW = ETON 19 SD 1 / 8 Ohm

## ER-4



- Air Motion Ribbon Tweeter
- New ribbon design
- High efficiency
- Suitable for center channel
- Flange 110 x 110mm
- Cut-out 90 x 90mm
- Depth 15mm

Znom	4 ohm	Sd	67 cm <sup>2</sup>
Re	3.5 ohm	BL	- N/A
Le@1kHz	- mH	Vas	- ltrs
fs	490 Hz	Xmax	- mm peak
Qms	-	VC Ø	- mm
Qes	-	Sensitivity	
Qts	-	1W / 1m	88 dB
Mms	0.66 g	Nom. Power DIN	60 W
Cms	- mm/N	Net weight	- kg

## 19 SD-1



- 3/4" Soft Dome Tweeter
- Response to 30 kHz
- Precoated textile dome
- Double magnet
- Vented polepiece
- Aluminum former and chassis
- Flange 110mm
- Cut-out 74mm
- Depth 43mm
- Great sounding tweeter

Znom	8 ohm	Sd	3.9 cm <sup>2</sup>
Re	6.3 ohm	BL	- N/A
Le@1kHz	0.20 mH	Vas	- ltrs
fs	1100 Hz	Xmax	- mm peak
Qms	-	VC Ø	19 mm
Qes	-	Sensitivity	
Qts	-	1W / 1m	89 dB
Mms	0.16 g	Nom. Power DIN	80 W
Cms	- mm/N	Net weight	- kg

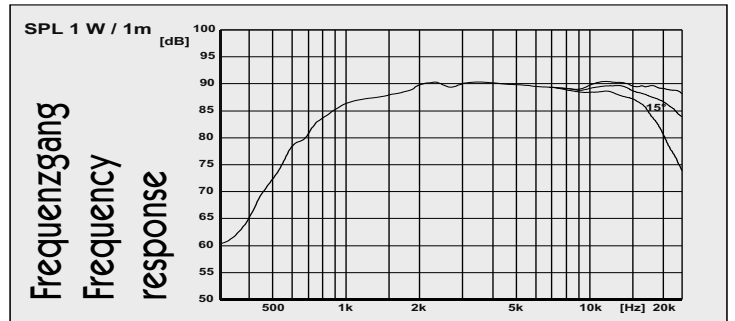
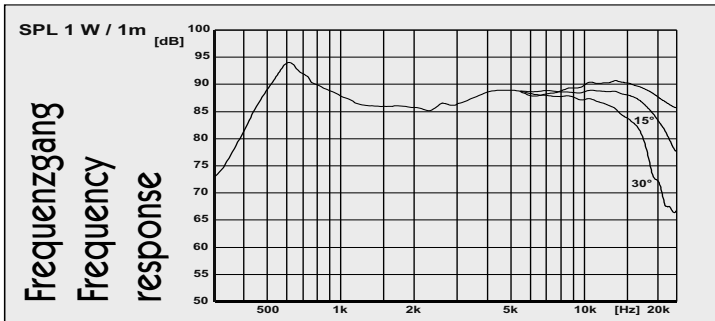

## 25 SD-1



- 1" Soft Dome Tweeter
- Response to 30 kHz
- Pre-coated textile dome
- Double magnet
- Vented pole piece
- Aluminum former and chassis
- Flange 110mm
- Cut-out 74mm
- Depth 43mm

Znom	8 ohm	Sd	6.5 cm <sup>2</sup>
Re	6.8 ohm	BL	- N/A
Le@1kHz	0.28 mH	Vas	- ltrs
fs	1000 Hz	Xmax	- mm peak
Qms	-	VC Ø	25 mm
Qes	-	Sensitivity	
Qts	-	1W / 1m	90 dB
Mms	0.22 g	Nom. Power DIN	100 W
Cms	- mm/N	Net weight	- kg

## 4-300/ 25HEX



- 4" HEXACONE Midrange
- Wide response
- Excellent sound quality
- Rubber surround
- Aluminum former and chassis
- Flange 120mm
- Cut-out 99mm
- Depth 66mm

Znom	8 ohm	Sd	55 cm <sup>2</sup>
Re	6.0 ohm	BL	5.17 N/A
Le@1kHz	- mH	Vas	4.8 ltrs
fs	61 Hz	Xmax	1.5 mm peak
Qms	1.72	VC Ø	25 mm
Qes	0.40	Sensitivity	
Qts	0.32	1W / 1m	88 dB
Mms	5.9 g	Nom. Power DIN	50 W
Cms	- mm/N	Net weight	- kg

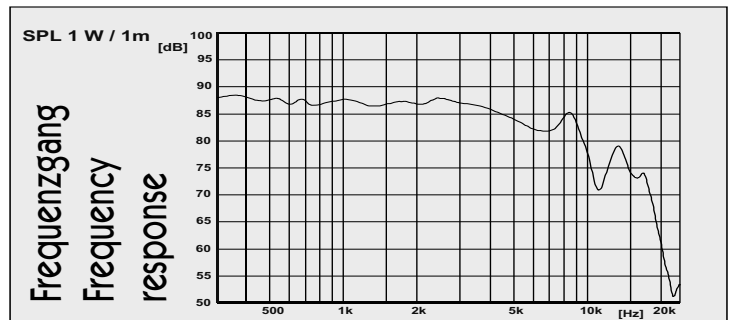
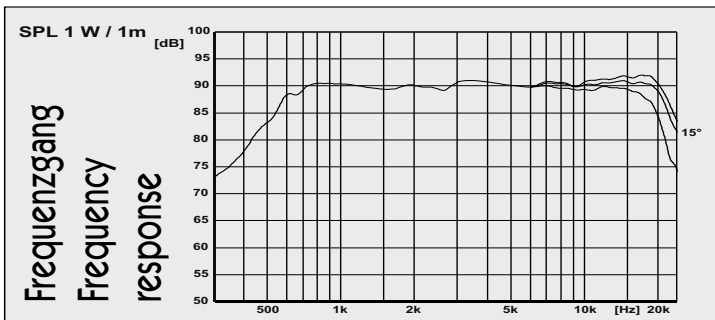

### 5-880/ 25HEX



- 5" HEXACONE Bass/Midrange
- Excellent for small monitors
- Excellent as midrange in multiple-way system
- 3mm X-max
- Flange 156mm
- Cut-out 128mm
- Depth 70mm

Znom	8 ohm	Sd	82 cm <sup>2</sup>
Re	6.6 ohm	BL	4.5 N/A
Le@1kHz	0.48 mH	Vas	8.7 ltrs
fs	52 Hz	Xmax	3 mm peak
Qms	2.29	VC Ø	25 mm
Qes	0.46	Sensitivity	
Qts	0.38	1W / 1m	87 dB
Mms	9.6 g	Nom. Power DIN	50 W
Cms	- mm/N	Net weight	- kg

### 7-360 / 37HEX



- 7" HEXACONE Bass/Midrange
- No coloration
- Excellent sound quality
- Rubber surround
- Aluminum diecast basket
- Flange 186mm
- Cut-out 160mm
- Depth 83mm

Znom	8 ohm	Sd	137 cm <sup>2</sup>
Re	5.6 ohm	BL	7.8 N/A
Le@1kHz	0.64 mH	Vas	20.0 ltrs
fs	43 Hz	Xmax	3.0 mm peak
Qms	2.74	VC Ø	37 mm
Qes	0.42	Sensitivity	
Qts	0.37	1W / 1m	89 dB
Mms	18 g	Nom. Power DIN	100 W
Cms	- mm/N	Net weight	- kg

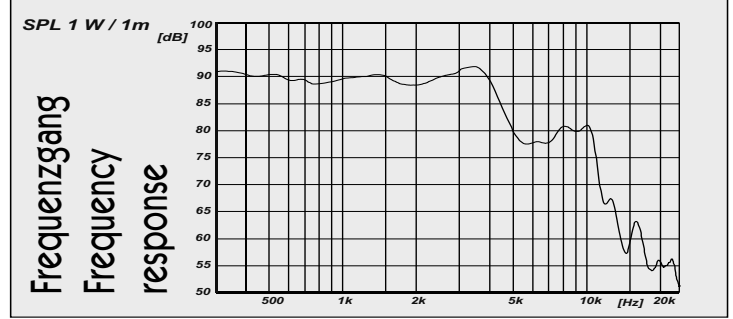
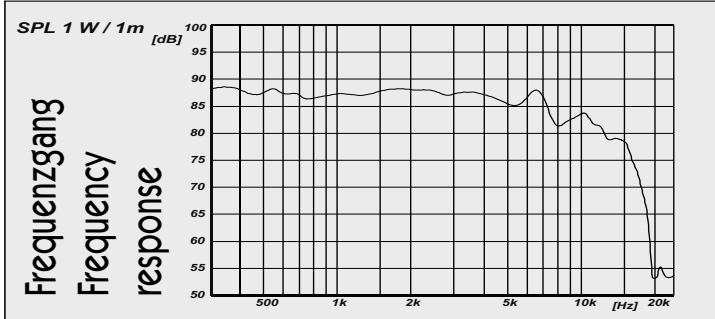

### 7-372/ 32LH



- 7" HEXACONE Woofer
- Constructed with new Heatpipe
- Long throw
- Rubber surround
- Aluminum diecast basket
- Flange 185mm
- Cut-out 151mm
- Depth 89mm

Znom	8 ohm	Sd	137 cm <sup>2</sup>
Re	7 ohm	BL	6.7 N/A
Le@1kHz	0.71 mH	Vas	44 ltrs
fs	32 Hz	Xmax	5.25 mm peak
Qms	3.78	VC Ø	32 mm
Qes	0.29	Sensitivity	
Qts	0.27	1W / 1m	88 dB
Mms	15.6 g	Nom. Power DIN	80 W
Cms	- mm/N	Net weight	- kg

### 7-375/ 32Hex



- 7" HEXACONE Woofer
- New motor and frame, designed to reduce distortion and improve aerodynamics
- rubber surround
- Aluminum dust cap
- aluminum diecast basket
- Flange 175mm
- Cut-out 152mm
- Depth 82mm

Znom	8 ohm	Sd	137 cm <sup>2</sup>
Re	6.8 ohm	BL	8.8 N/A
Le@1kHz	0.85 mH	Vas	26 ltrs
fs	38 Hz	Xmax	4 mm peak
Qms	2.40	VC Ø	32 mm
Qes	0.37	Sensitivity	
Qts	0.32	1W / 1m	88 dB
Mms	17 g	Nom. Power DIN	70 W
Cms	- mm/N	Net weight	- kg

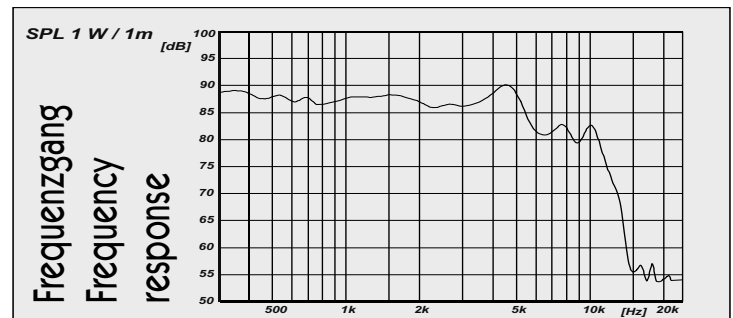
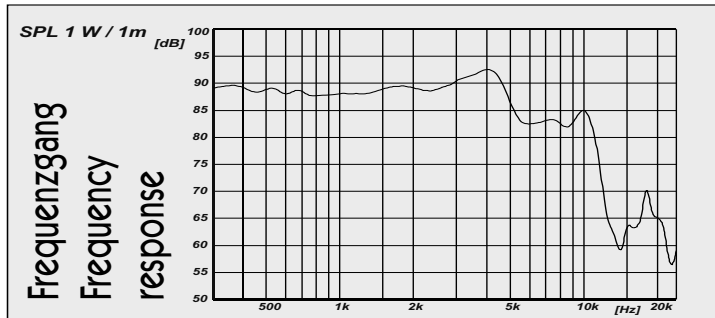



### 8-472/ 32 LH



- 8" HEXACONE Woofer
- Constructed with new Heatpipe
- Long throw
- Rubber surround
- Aluminum diecast basket
- Flange 223mm
- Cut-out 186mm
- Depth 108mm

Znom	8 ohm	Sd	219 cm <sup>2</sup>
Re	7 ohm	BL	6.7 N/A
Le@1kHz	- mH	Vas	116 ltrs
fs	24 Hz	Xmax	5.25 mm peak
Qms	3.55	VC Ø	32 mm
Qes	0.32	Sensitivity	
Qts	0.29	1W / 1m	88 dB
Mms	27 g	Nom. Power DIN	90 W
Cms	- mm/N	Net weight	- kg

### 8-800/ 37HEX



- 8" HEXACONE Woofer
- Excellent sound characteristics
- Outstanding pulse response
- Aluminum diecast basket
- Flange 228mm
- Cut-out 202mm
- Depth 96mm

Znom	8 ohm	Sd	235 cm <sup>2</sup>
Re	5.5 ohm	BL	9.3 N/A
Le@1kHz	0.69 mH	Vas	45.5 ltrs
fs	36 Hz	Xmax	3.0 mm peak
Qms	2.44	VC Ø	37 mm
Qes	0.46	Sensitivity	
Qts	0.39	1W / 1m	89 dB
Mms	31 g	Nom. Power DIN	120 W
Cms	- mm/N	Net weight	- kg

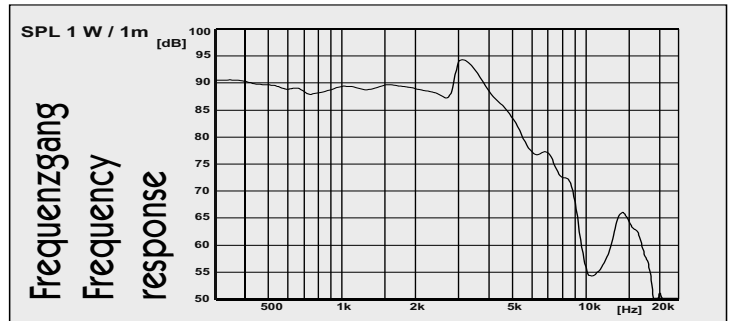
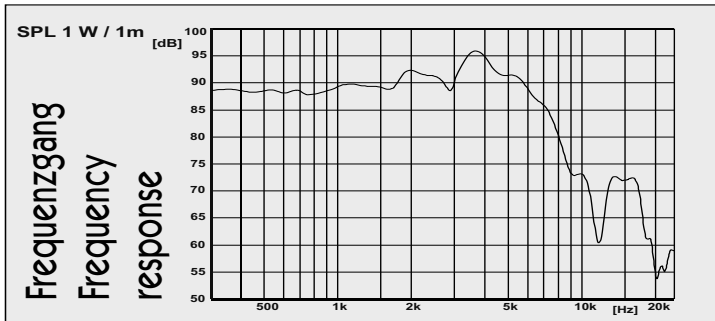

### 11-581/ 50HEX



- 11" HEXACONE Woofer
- Low frequency reproduction
- Excellent pulse response
- Aluminum diecast basket
- Flange 280mm
- Cut-out 244mm
- Depth 104mm

Znom	8 ohm	Sd	366 cm <sup>2</sup>
Re	5.2 ohm	BL	12.4 N/A
Le@1kHz	0.69 mH	Vas	153 ltrs
fs	21 Hz	Xmax	5.0 mm peak
Qms	6.68	VC Ø	50 mm
Qes	0.31	Sensitivity	
Qts	0.30	1W / 1m	91 dB
Mms	67.3 g	Nom. Power DIN	150 W
Cms	- mm/N	Net weight	- kg

### 12-680/ 62HEX



- 12" HEXACONE Woofer
- Low frequency reproduction
- Excellent pulse response
- Aluminum diecast basket
- Flange 315mm
- Cut-out 291mm
- Depth 143mm

Znom	8 ohm	Sd	515 cm <sup>2</sup>
Re	6.1 ohm	BL	15.6 TM
Le@1kHz	1.45 mH	Vas	150 ltrs
fs	26 Hz	Xmax	6 mm peak
Qms	3.52	VC Ø	62 mm
Qes	0.38	Sensitivity	
Qts	0.34	1W / 1m	91 dB
Mms	92 g	Nom. Power DIN	200 W
Cms	- mm/N	Net weight	- kg

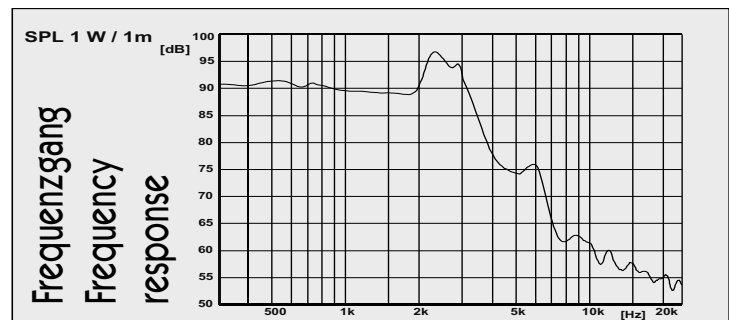
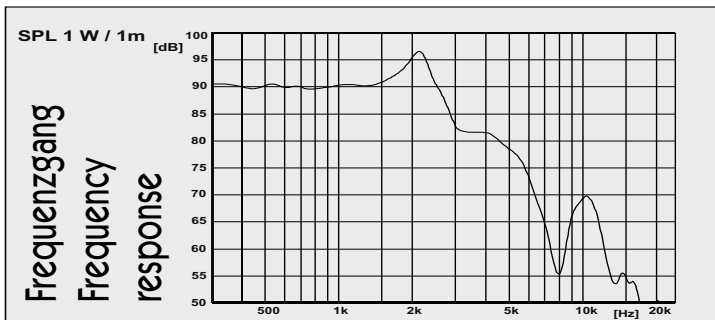



Visit our web page for more specifications and cabinet designs.  
[www.madisound.com](http://www.madisound.com) & [www.fostex.jp](http://www.fostex.jp)

Model	Imp. W	Fs Hz	Qts	Vas Ltrs	Power Watts	dB	Frequency Range	Xmax mm P	Box Liter Sealed/Vented	F3 Hz	Price Each
<b>FT SERIES RIBBON TWEETER - Patented "Regulated Phase" Full surface drive diaphragm.</b>											
FT7RP ribbon tweeter	8				80	93	3.5K-45kHz				\$83.60
<b>FT SERIES DOME TWEETER</b>											
FT207D dome tweeter, grill, <b>Shielded</b>	8				60	90	3K-40kHz				\$40.20
FT28D dome tweeter	8				40	90	2.5K-50kHz				\$57.05
FT48D dome tweeter	8				50	93	2K-30kHz				\$80.70
<b>FT SERIES HORN TWEETER</b>											
FT17H horn tweeter	8				30	98.5	5K-50kHz				\$35.65
FT96H horn super tweeter, alnico magnet	8				50	100	3K-33kHz				\$106.25
<b>T SERIES HORN TWEETERS, ALNICO MAGNET</b>											
T90A top mount, super tweeter, alnico magnet	8				50	106	7K-35kHz				\$141.65
T90A-EX triple alnico magnet version of T90A	8				50	110	5k-100kHz				\$335.00
T925A top mount, super tweeter, alnico magnet	8				50	108	6K-40kHz				\$263.60
T500AMK2 top mount, super tweeter, alnico	8				50	110	4K-45kHz				\$707.20
T900A top mount, super tweeter, alnico magnet	8				60	106	5K-38kHz				\$338.30
<b>F SERIES ALNICO MAGNET - Suitable for folded horn enclosures. Mica composite coated cones. - Discontinued - Get them while they last!</b>											
F120A 4.5" full range, alnico magnet	8	65	0.44	9.87	30	89	Fo-20kHz	1.5	6S/12V	105/58	\$218.50
F200A 8" full range, alnico magnet	8	30	0.32	98.96	80	90	Fo-20kHz	2.0	25S/38V	67/45	\$373.70
<b>FX SERIES - Bio-cellulose cone made from kenaf with special mica composite coating - Discontinued - Get them while they last!</b>											
FX120 5" full range	8	70	0.45	8.21	30	89	Fo-20kHz	2.0	5.4S/11V	111/60	\$98.00
<b>FE SIGMA "E" SERIES FULL RANGE DRIVERS - Suitable for folded horn enclosures.</b>											
FE108EΣ; 4" full range	8	77	0.30	5.7	24	90	Fo-23kHz	0.28	Horn	fs	\$85.00
FE168EΣ; 6.5" full range	8	51	0.26	23.7	80	94.5	Fo-21kHz	1.6	Horn	fs	\$139.00
FE208EΣ; 8" full range	8	42	0.18	60.1	120	97	Fo-14kHz	1.25	Horn	fs	\$175.00
<b>FE- E SERIES - Suitable for folded horn enclosures, banana pulp cones.</b>											
FE83E 3" full range	8	140	0.78	1.293	10	88	Fo-20kHz	0.4	2-4S	140-135	\$24.75
FE87E 3" full range - <b>Shielded</b>	8	140	0.92	1.03	10	89	Fo-30kHz	0.4	3-5S	125-120	\$27.55
FE103E 4" full range	8	80	0.35	6.89	15	89	Fo-22kHz	0.4	2.4S/3V	158/100	\$31.50
FE107E 4" full range - <b>Shielded</b>	8	80	0.38	5.95	15	90	Fo-22kHz	0.35	2.4S/4V	148/89	\$33.50
FE126E 4.5" full range	8	70	0.25	9.95	45	93	Fo-25kHz	0.35	1.5S/2V	200/165	\$35.50
FE127E 4.5" full range - <b>Shielded</b>	8	70	0.43	9.9	45	91	Fo-20kHz	0.35	6S/12V	114/62	\$36.50
FE166E 6.5" full range	8	50	0.21	45.11	65	94	Fo-22kHz	0.6	4.5S/5V	170/125	\$61.05
FE167E 6.5" full range - <b>Shielded</b>	8	50	0.33	30.2	65	95	Fo-22kHz	0.6	8.4S/18V	118/69	\$63.25
FE206E 8" full range	8	39	0.18	54.5	90	96	Fo-20kHz	1.5	45V	55	\$84.30
FE207E 8" full range - <b>Shielded</b>	8	39	0.26	56.25	90	95	Fo-20kHz	1.5	9S/17V	108/68	\$86.50
<b>FF SERIES - Suitable for folded horn enclosures, using kenaf fiber cones.</b>											
FF85K 3" full range, fiber cone, up/down surr.	8	122	0.47	1.07	10	88	Fo-33kHz	0.55	0.9S/2V	181/94	\$32.15
FF125K 4.5" full range, fiber cone	8	72	0.26	9.12	50	92	Fo-18kHz	0.15	1.5S/2V	195/135	\$40.00
FF165K 6.5" full range, fiber cone	8	40	0.20	48.2	70	94	Fo-17kHz	0.3	4.5S/7V	135/94	\$61.10
FF225K 8" full range, fiber cone	8	38	0.16	79.41	100	96	Fo-14kHz	0.3	Horn	fs	\$94.35
<b>FW SERIES - Poly cones with shielded magnets.</b>											
FW137 5.5" woofer, Paper cone - <b>Shielded</b>	8	55	0.5	10.2	75	87	Fo-8kHz	1.0	9S/10V	80/55	\$55.70
FW167 6.5" woofer, Paper cone - <b>Shielded</b>	8	40	0.36	25.22	100	89	Fo-8kHz	1.5	8S/12V	80/50	\$83.65
<b>FW-HP SERIES - Banana pulp hyperbolic cone with up/down surround and up/down spider.</b>											
FW168HP 6.5" woofer, hyperbolic	8	40	0.16	14.25	100	89	Fo-10kHz	0.5	7S/14V	98/47	\$230.00
FW168HP-X 6.5" woofer, hyperbolic	8	70	0.53	5.84	100	88	Fo-10kHz	2.7	20V	45	\$230.00
<b>FW SERIES - Hybrid pulp cone woofers</b>											
FW108N 4" woofer	8	55	0.26	4.09	50	86	Fo-10kHz	1.9	0.7S/1V	148/93	\$108.25
FW168N 6.5" woofer	8	40	0.16	14.25	100	89	Fo-9kHz	0.5	4S/5V	200/80	\$139.75
FW208N 8" woofer	8	29	0.2	43.42	100	90	Fo-5kHz	6.5	4.1S/7V	99/68	\$160.50
FW800N 31.5" super woofer	8	18	0.69	3201	450	96	Fo-1.5kHz	2.3	Inf. Baffle	Fo	\$2,446.00
<b>ATTENUATOR</b>											
R80B L-pad	8				100		Attenuation 0-40dB				\$21.10
R82B L-pad	8				200		Attenuation 0-40dB				\$36.75
R100T transformer type	8				100		Attenuation 0-21dB in 1dB steps				\$170.90
<b>Commercial Use Horn Tweeters for PA or Professional Sound Systems</b>											
100HT 3" x 4" Horn tweeter	8	1750			100	102	5k-20kHz				\$37.60
400HT 4" x 10" Horn Tweeter	8	1300			120	108	3k-15kHz				\$87.40
H400 Wooden Horn, 1" throat, 455Hz					15.59" Wide by 4.72" Tall by 8.9" Deep; Natural Maple					\$470.20	
D1405 Compression Horn Driver, alnico	8	800	3.5 pounds		60	104	850Hz - 20kHz	Titanium diaphragm			\$262.80
D1400 Compression Horn Drivers, alnico	8	650	7.6 pounds		60	104	750Hz - 20kHz	Titanium diaphragm			\$451.30

Visit our web site for information on the limited edition FE206E-SR 8" full range. This will be the one and only production run of this driver. Fostex sees the special edition drivers as an art form, not to be reproduced.

# Fostex

## Copper Foil/Tin Foil & PPTA



The Fostex CS capacitors are made from separate layers of Copper Foil, Tin Foil and PPTA Film (poly p-phenylene terephthalamide). The CS

caps have solid copper leads. These caps are very densely wrapped, more than twice the weight of similar value capacitors. Non-inductive. 120VAC

Unit	Size mm	Price	Unit	Size mm	Price
0.33	14 Ø x 37	\$23.50	1.50	18 Ø x 62	\$32.00
0.47	16 Ø x 37	\$23.50	2.20	21 Ø x 62	\$38.50
0.68	19 Ø x 37	\$24.50	3.30	25 Ø x 62	\$48.00
1.00	20 Ø x 37	\$27.75			

# Fostex

## Brass Isolation Rings for the

## "Sigma" Series Speakers



These beautifully crafted brass rings are designed to isolate the Sigma speaker from the cabinet. The brass rings have 8 screw holes for mounting the ring to the cabinet and 8 machined bolt holes to mount the driver to the ring. Mounting hardware is included.

Item	Price Each
P108	\$143.00
P168	\$183.00
P208	\$239.00

# Fostex

## Protective Grills



Metal mesh grills with plastic outer housing. Comes with mounting hardware. Please see our web site for a more detailed list of driver/grill matings. No grill for the Sigma drivers.

Unit	Description	Price Pair
K308	For 8cm square frame	\$17.80
KG810	For 10cm sq or rnd frame	\$28.90
K312	For 12cm square frame	\$24.50
KG816	For 16cm sq or rnd frame	\$48.90
KG820	For 20cm sq or rnd frame	\$65.40

# Fostex

## HP Sound Reflectors



The HP Sound Reflectors are designed to be used in folded horn enclosures to reduce standing wave problems. When properly placed, the HP Sound Reflectors will reduce resonance peaks in

the higher frequencies and cut down on frequency cancellations in the lower frequencies. Made from plastic.

Price per 5 pack: \$48.90



# BK-16 Kit



Madisound is pleased to offer the BK-16 folded horn kit. We have chosen the **Fostex FF165K** 6.5" full range for use in the BK-16 cabinet. The **FF165K** has a **Kenaf** fiber cone, inverted foam surround and aluminum dust cap.

The **FF165K** is run full range with a frequency response out to 15kHz. The **T90A** super tweeter has been added to cover the upper frequencies. The **T90A** is a top-mount horn tweeter with an **Alnico magnet**. The tweeter is rolled off on the low end with a **Fostex Tin & Copper foil capacitor**. The system frequency response is 55Hz to 35kHz at 95dB.

The **BK-16** cabinet is made from **Baltic Birch** plywood and is sold flat, unassembled, unsanded and unfinished. Cabinet dimensions are 9.75" W x 14.75" D x 29" T.

The Kit Includes:

- Pair of Cabinets - Flat
- Pair of FF165K - Full range
- Pair of T90A - horn tweeter
- Pair of DB-cup - Input cup
- Pair of Crossovers
- Nordost 2-Flat wire for tweeter
- Instructions

**Kit Price: \$635.00 / pair**  
**Parts without Cabinets: \$439 /pair**  
**Cabinets only: \$98.00 each**



## Nagaoka Tetsuo's

### Special Technique to Design the Original Speakers

Book #5 from the set.

The Nagaoka Tetsuo book series is published in cooperation with Ontomo Mook Audio. The books are written in Japanese. They are filled with different speaker designs of all types. Even if you don't read Japanese, you can still construct the speakers from the drawings and crossover schematics. Most systems are using the Fostex speakers and most are full range, not requiring a crossover.



This is a must have for any full range speaker hobbyist.

**Price for book 5: \$14.00**

The rest of the books in this 5 book series will not be published again.

## T90A-EX \$335.00



**Fostex**

- Horn Super Tweeter with pure magnesium diaphragm.
- Frequency response: 5kHz to 35kHz  
15kHz to 100kHz
- 104dB 5k to 35kHz
- 88dB 15k to 100kHz
- Silver/Copper VC wire
- Triple Alnico magnet
- 52mmØ x 137mm

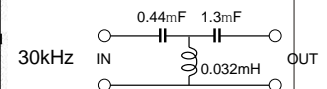
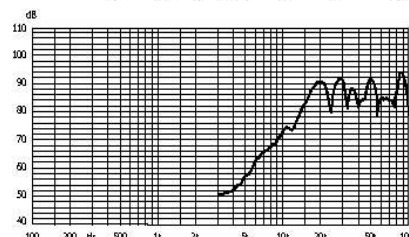
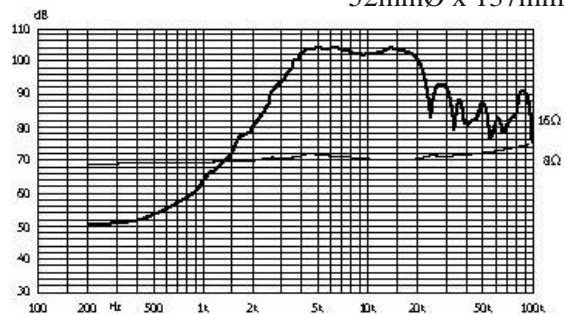



**FT7RP \$83.60**

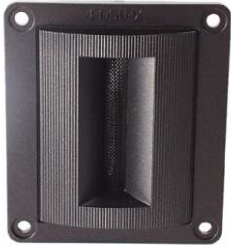

**Fostex**

- RIBBON TWEETER
- 8 ohm impedance
- Frequency response from 3kHz to 45kHz
- 93dB sensitivity at 1w/1m (3.3ft)
- Flange 76mm x 86mm
- Cut-out 50mm
- Depth 32mm

Znom	8	ohm	Sd	-	cm <sup>2</sup>
Re	-	ohm	BL	-	N/A
Le@1kHz	-	mH	Vas	-	ltrs
fs	3000	Hz	Xmax	-	mm peak
Qms	-		VC Ø	-	mm
Qes	-		Sensitivity		
Qts	-		1W / 1m	93	dB
Mms	-	g	<b>Nom. Power</b>	<b>80</b>	<b>W</b>
Cms	-	mm/N	Net weight	155	g

**FT207D \$40.20**



**Fostex**

- DOME TWEETER
- 20mm textile dome
- Shielded magnet
- Frequency response from 3kHz to 40kHz
- 90dB sensitivity at 1w/1m (3.3ft)
- Flange 95mm round
- Cut-out 70 mm
- Depth 34.4mm

Znom	8	ohm	Sd	-	cm <sup>2</sup>
Re	-	ohm	BL	-	N/A
Le@1kHz	-	mH	Vas	-	ltrs
fs	1000	Hz	Xmax	-	mm peak
Qms	-		VC Ø	-	mm
Qes	-		Sensitivity		
Qts	-		1W / 1m	90	dB
Mms	-	g	<b>Nom. Power</b>	<b>60</b>	<b>W</b>
Cms	-	mm/N	Net weight	390	g

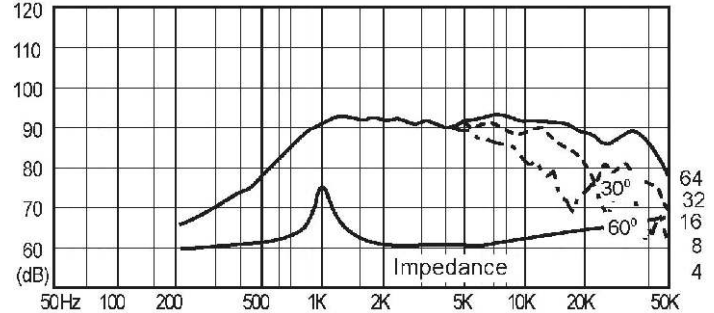
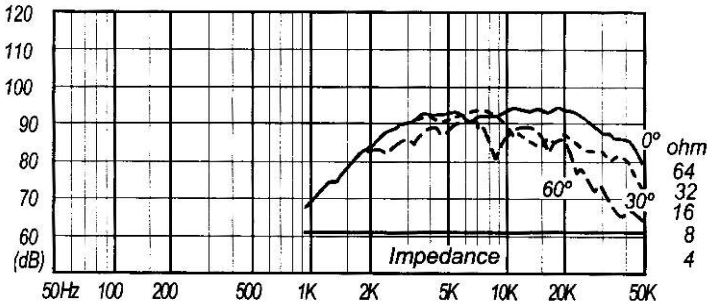

**FT28D \$57.05**



**Fostex**

- DOME TWEETER
- 8 ohm impedance
- 1kHz to 50kHz frequency response
- 90dB sensitivity at 1w/1m (3.3ft)
- Flange 90mm x 78mm
- Cut-out 70mm
- Depth 32.8mm

Znom	8	ohm	Sd	-	cm <sup>2</sup>
Re	-	ohm	BL	-	N/A
Le@1kHz	-	mH	Vas	-	ltrs
fs	1000	Hz	Xmax	-	mm peak
Qms	-		VC Ø	-	mm
Qes	-		Sensitivity		
Qts	-		1W / 1m	90	dB
Mms	-	g	<b>Nom. Power</b>	<b>40</b>	<b>W</b>
Cms	-	mm/N	Net weight	528	g

**FT48D \$80.70**



**Fostex**

- DOME TWEETER
- 8 ohm impedance
- 33mm Dome
- Frequency response from 800kHz to 30kHz
- 93dB sensitivity
- Felt front
- Flange 128mm
- Cut-out 90mm
- Depth 38.7mm

Znom	8	ohm	Sd	-	cm <sup>2</sup>
Re	-	ohm	BL	-	N/A
Le@1kHz	-	mH	Vas	-	ltrs
fs	800	Hz	Xmax	-	mm peak
Qms	-		VC Ø	-	mm
Qes	-		Sensitivity		
Qts	-		1W / 1m	93	dB
Mms	-	g	<b>Nom. Power</b>	<b>50</b>	<b>W</b>
Cms	-	mm/N	Net weight	978	g

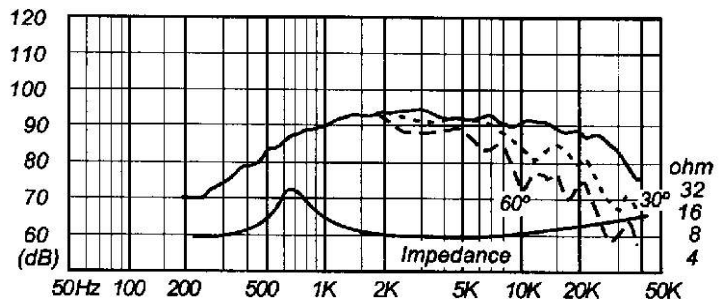
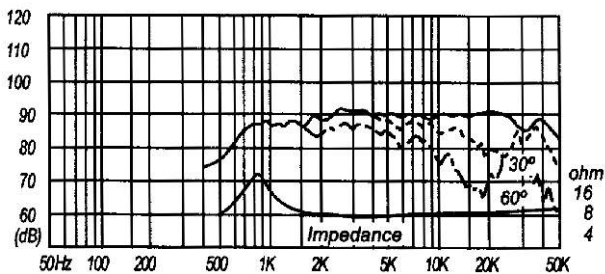

## FT17H \$35.65



**Fostex**

- HORN SUPER TWEETER
- 8 ohm impedance
- Frequency response from 5kHz to 50kHz
- 98.5dB sensitivity at 1w/1m (3.3 ft)
- Flange 87mm
- Cut-out 63mm
- Depth 38.5mm

Znom	8	ohm
Re	-	ohm
Le@1kHz	-	mH
fs	5000	Hz
Qms	-	
Qes	-	
Qts	-	
Mms	-	g
Cms	-	mm/N

Sd	-	cm <sup>2</sup>
BL	-	N/A
Vas	-	ltrs
Xmax	-	mm peak
VC Ø	-	mm
Sensitivity		
1W / 1m	98.5	dB
<b>Nom. Power</b>	<b>30</b>	<b>W</b>
Net weight	340	g

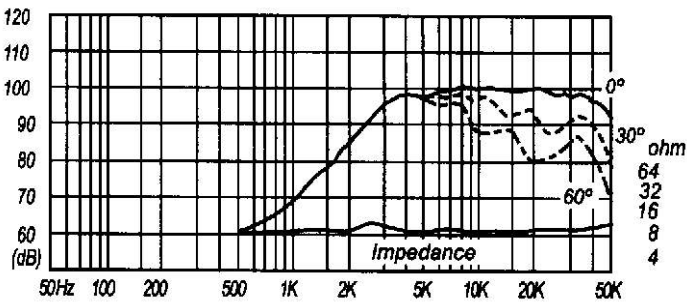

## FT96H \$106.25



**Fostex**

- HORN SUPER TWEETER
- 8 ohm impedance
- Frequency response 4kHz to 33kHz
- 100dB sensitivity 1w/1m
- Alnico magnet
- Flange 68mm square
- Cut-out 60mm
- Depth 60mm

Znom	8	ohm
Re	-	ohm
Le@1kHz	-	mH
fs	4000	Hz
Qms	-	
Qes	-	
Qts	-	
Mms	-	g
Cms	-	mm/N

Sd	-	cm <sup>2</sup>
BL	-	N/A
Vas	-	ltrs
Xmax	-	mm peak
VC Ø	-	mm
Sensitivity		
1W / 1m	100	dB
<b>Nom. Power</b>	<b>50</b>	<b>W</b>
Net weight	600	g

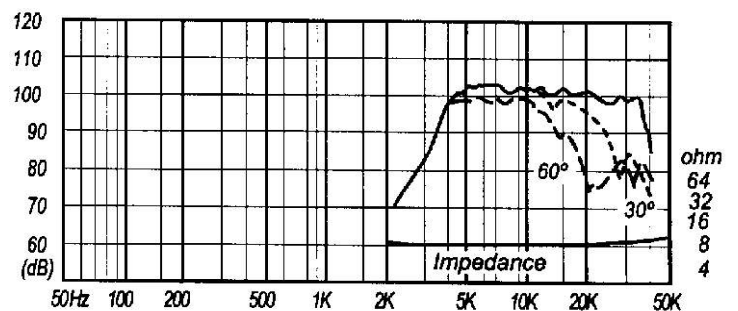

## T90A \$141.65



**Fostex**

- HORN SUPER TWEETER
- 8 ohm impedance
- Frequency response from 5kHz to 35kHz
- 106dB sensitivity at 1w/1m (3.3ft)
- TOP MOUNT
- Flange 60 mm
- Depth 74.1/ 87.8 mm

Znom	8	ohm
Re	-	ohm
Le@1kHz	-	mH
fs	5000	Hz
Qms	-	
Qes	-	
Qts	-	
Mms	-	g
Cms	-	mm/N

Sd	-	cm <sup>2</sup>
BL	-	N/A
Vas	-	ltrs
Xmax	-	mm peak
VC Ø	-	mm
Sensitivity		
1W / 1m	106	dB
<b>Nom. Power</b>	<b>50</b>	<b>W</b>
Net weight	800	g

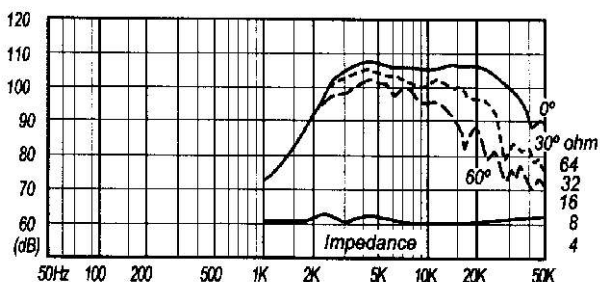

## T925A \$263.60



**Fostex**

- HORN SUPER TWEETER
- 8 ohm impedance
- Frequency response from 5kHz to 40kHz
- 108dB sensitivity at 1w/1m (3.3ft)
- TOP MOUNT
- Flange 82 mm
- Depth 91/ 108mm

Znom	8	ohm
Re	-	ohm
Le@1kHz	-	mH
fs	5000	Hz
Qms	-	
Qes	-	
Qts	-	
Mms	-	g
Cms	-	mm/N

Sd	-	cm <sup>2</sup>
BL	-	N/A
Vas	-	ltrs
Xmax	-	mm peak
VC Ø	-	mm
Sensitivity		
1W / 1m	108	dB
<b>Nom. Power</b>	<b>50</b>	<b>W</b>
Net weight	2.0	Kg

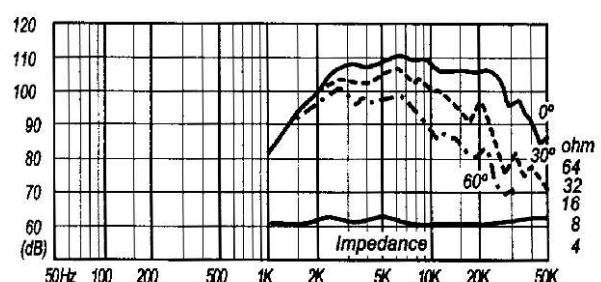

**T500AMKII \$707.20**



- Horn Super Tweeter
- Pure Magnesium diaphragm
- Silver/Copper VC wire
- Frequency response from 4kHz to 45kHz
- 110dB sensitivity
- Copper terminals
- Solid Brass horn body
- Double alnico magnets

**Fostex**

Znom	8	ohm
fs	4000	Hz
Sensitivity	110	dB
1W / 1m		

<b>Nom. Power</b>	<b>50</b>	<b>W</b>
Net weight	5.0	Kg
Recommended x-over frequency	more than 7kHz (12dB/Oct.)	

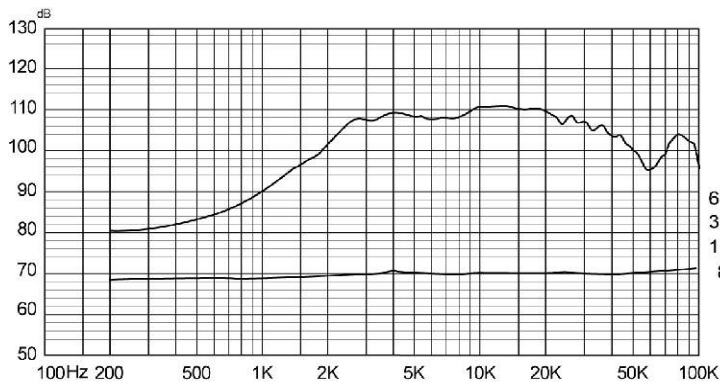

**T900A \$338.30**



- HORN SUPER TWEETER
- 8 ohm impedance
- Frequency response from 5kHz to 38kHz
- 106 dB sensitivity 1w/1m
- TOP MOUNT
- Flange 82mm
- Depth 81.8mm/ 98.3mm

**Fostex**

Znom	8	ohm
Re		ohm
Le@1kHz	-	mH
fs	-	Hz
Qms	-	
Qes	-	
Qts	-	
Mms	-	g
Cms	-	mm/N

Sd	-	cm <sup>2</sup>
BL	-	N/A
Vas	-	ltrs
Xmax	-	mm peak
VC Ø	-	mm
Sensitivity	106	dB
1W / 1m		
<b>Nom. Power</b>	<b>60</b>	<b>W</b>
Net weight	3.55	Kg

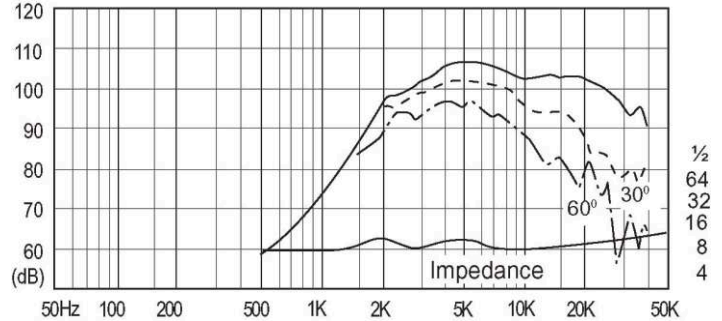

**F120A \$218.50**



- 5" FULL RANGE
- Alnico Magnet
- 8 ohm impedance
- Frequency response from 65Hz to 20kHz
- 89dB sensitivity
- Flange 137 x 123mm HEXAGONAL
- Cut-out 103mm
- Depth 88mm

**Fostex**

Znom	8	ohm
Re	7	ohm
Le@1kHz	-	mH
fs	65	Hz
Qms	3.1	
Qes	.51	
Qts	.44	
Mms	4.7	g
Cms	-	mm/N

Sd	-	cm <sup>2</sup>
BL	-	N/A
Vas	9.87	ltrs
Xmax	1.5	mm peak
VC Ø	-	mm
Sensitivity	89	dB
1W / 1m		
<b>Nom. Power</b>	<b>30</b>	<b>W</b>
Net weight	2.0	Kg

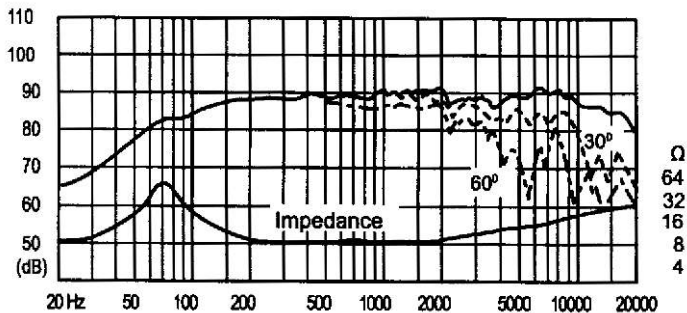

**F200A \$373.80**



- 8" FULL RANGE
- Alnico magnet
- 8 ohm impedance
- Frequency response from 30Hz to 20kHz
- 90 dB sensitivity
- Flange 213 X 194mm HEXAGONAL
- Cut-out 182 mm
- Depth 123.7 mm

**Fostex**

Znom	8	ohm
Re	7.3	ohm
Le@1kHz	-	mH
fs	30	Hz
Qms	2.63	
Qes	0.36	
Qts	0.32	
Mms	18.6	g
Cms	-	mm/N

Sd	-	cm <sup>2</sup>
BL	-	N/A
Vas	98.96	ltrs
Xmax	2.0	mm peak
VC Ø	-	mm
Sensitivity	90	dB
1W / 1m		
<b>Nom. Power</b>	<b>80</b>	<b>W</b>
Net weight	4.4	kg

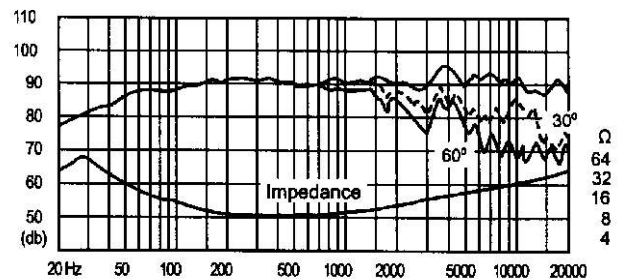



## FX120 \$98.70



**Fostex**

- 5" FULL RANGE
- KENAF paper/ fiber composite cone
- 89db sensitivity
- Frequency response from 70 Hz to 20kHz
- Flange 137 x 123mm HEXAGONAL
- Cut-out 103 mm
- Depth 54.5 mm

Znom	8	ohm
Re	7.3	ohm
Le@1kHz	-	mH
fs	70	Hz
Qms	8.4	
Qes	0.47	
Qts	0.45	
Mms	5.3	g
Cms	-	mm/N

Sd	-	cm <sup>2</sup>
BL	-	N/A
Vas	8.21	ltrs
Xmax	2.0	mm peak
VC Ø	-	mm
Sensitivity		
1W / 1m	89	dB
<b>Nom. Power</b>	<b>30</b>	<b>W</b>
Net weight	1.32	kg

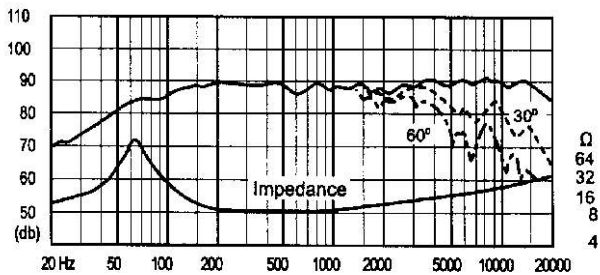

## FE108EΣ \$85.00



**Fostex**

- 4" FULL RANGE
- HP shell diaphragm
- Banana pulp cone
- UDR surround
- Frequency response from 77Hz to 23kHz
- 90dB sensitivity
- Flange 128 mm
- Cutout 98mm
- Depth 65mm

Znom	8	ohm
Re	6.8	ohm
Le@1kHz	.038	mH
fs	77	Hz
Qms	7.79	
Qes	0.32	
Qts	0.3	
Mms	2.7	g
Cms	1.59	mm/N

Sd	0.005	m <sup>2</sup>
BL	5.2	N/A
Vas	5.7	ltrs
Xmax	0.28	mm peak
VC Ø	20	mm
Sensitivity		
1W / 1m	90	dB
<b>Nom. Power</b>	<b>24</b>	<b>W</b>
Net weight	1200	g

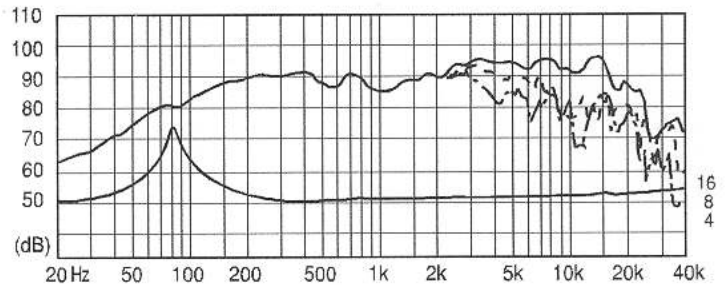

## FE168EΣ \$139.00



**Fostex**

- 6.5" FULL RANGE
- HP shell diaphragm
- Banana pulp cone
- UDR surround
- Frequency response from 51Hz to 21kHz
- 94.5dB sensitivity
- Flange 190 mm
- Cutout 146mm
- Depth 88mm

Znom	8	ohm
Re	6.8	ohm
Le@1kHz	.056	mH
fs	51	Hz
Qms	5.328	
Qes	0.27	
Qts	0.26	
Mms	8.7	g
Cms	1.278	mm/N

Sd	0.0113	m <sup>2</sup>
BL	8	N/A
Vas	23.7	ltrs
Xmax	1.6	mm peak
VC Ø	30	mm
Sensitivity		
1W / 1m	94.5	dB
<b>Nom. Power</b>	<b>80</b>	<b>W</b>
Net weight	2600	g

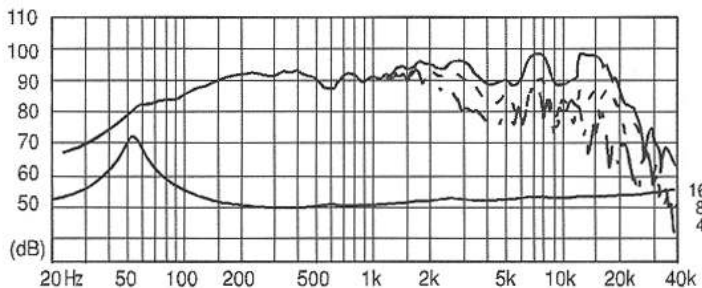

## FE208EΣ \$175.00



**Fostex**

- 8" FULL RANGE
- HP shell diaphragm
- Banana pulp cone
- UDR surround
- Frequency response from 42Hz to 14kHz
- 97dB sensitivity
- Flange 230 mm
- Cutout 182mm
- Depth 93.5mm

Znom	8	ohm
Re	6.4	ohm
Le@1kHz	0.051	mH
fs	42	Hz
Qms	6.19	
Qes	0.19	
Qts	0.18	
Mms	13.3	g
Cms	1.069	mm/N

Sd	0.0201	m <sup>2</sup>
BL	10.8	N/A
Vas	60.1	ltrs
Xmax	1.25	mm peak
VC Ø	35	mm
Sensitivity		
1W / 1m	97	dB
<b>Nom. Power</b>	<b>120</b>	<b>W</b>
Net weight	4800	g

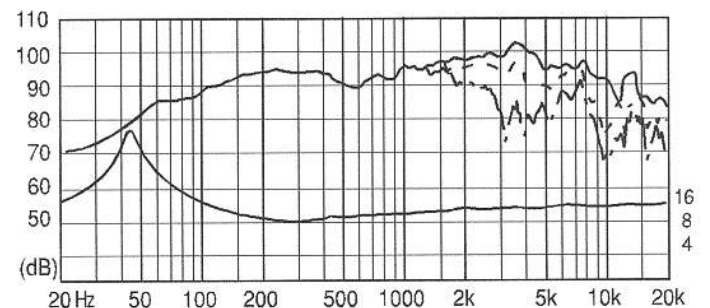



### FE83E \$24.75



- 3" FULL RANGE
- ES banana pulp cone
- New center cap
- Frequency response from 127 Hz to 20kHz
- 88dB sensitivity
- Flange 83mm
- Cut-out 71mm
- Depth 40.2mm

**Fostex**

Znom	8	ohm	Sd	.0028	m <sup>2</sup>
Re	7.8	ohm	BL	2.98	N/A
Le@1kHz	-	mH	Vas	1.29	ltrs
fs	127	Hz	Xmax	0.4	mm peak
Qms	4.00		VC Ø	16	mm
Qes	0.98		Sensitivity		
Qts	0.79		1W / 1m	88	dB
Mms	1.39	g	<b>Nom. Power</b>	<b>10</b>	<b>W</b>
Cms	0.0012	mm/N	Net weight	360	g

### FE87E \$27.55



- 3" SHIELDED FULL RANGE
- ES banana pulp cone
- New center cap
- Frequency response from 140 Hz to 30kHz
- 89dB sensitivity
- Flange 83mm
- Cut-out 71mm
- Depth 41.2mm

**Fostex**

Znom	8	ohm	Sd	.0028	m <sup>2</sup>
Re	7.7	ohm	BL	2.81	N/A
Le@1kHz	-	mH	Vas	1.03	ltrs
fs	140	Hz	Xmax	0.4	mm peak
Qms	3.77		VC Ø	16	mm
Qes	1.2		Sensitivity		
Qts	0.92		1W / 1m	89	dB
Mms	1.4	g	<b>Nom. Power</b>	<b>15</b>	<b>W</b>
Cms	0.0009	mm/N	Net weight	288	g

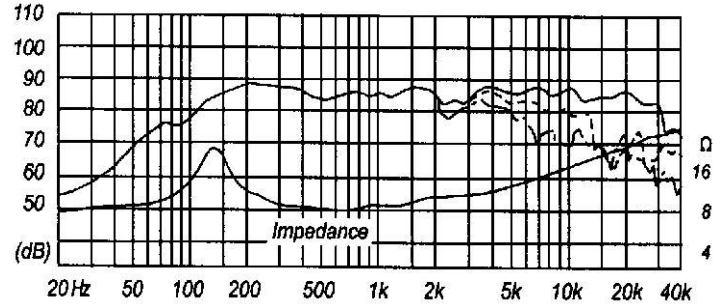
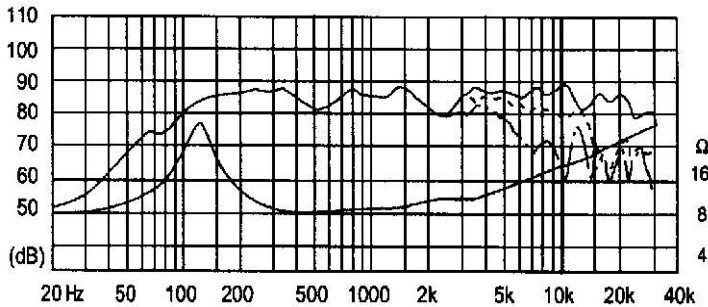

### FE103E \$31.50



- 4" FULL RANGE
- ES banana pulp cone
- New center cap
- 8 ohm impedance
- Frequency response 79.5 Hz to 22kHz
- 89dB sensitivity
- Flange 107mm
- Cut-out 92mm
- Depth 43.6mm

**Fostex**

Znom	8	ohm	Sd	0.005	m <sup>2</sup>
Re	7.45	ohm	BL	4.42	N/A
Le@1kHz	-	mH	Vas	6.90	ltrs
fs	79.5	Hz	Xmax	0.35	mm peak
Qms	2.87		VC Ø	20	mm
Qes	0.40		Sensitivity		
Qts	0.36		1W / 1m	89	dB
Mms	2.1	g	<b>Nom. Power</b>	<b>15</b>	<b>W</b>
Cms	0.0019	mm/N	Net weight	630	g

### FE107E \$33.50



- 4" SHIELDED FULL RANGE
- ES banana pulp cone
- 8 ohm impedance
- 90dB sensitivity
- Frequency response to 22kHz
- Flange 107mm
- Cut-out 92mm
- Depth 54.7mm

**Fostex**

Znom	8	ohm	Sd	0.005	cm <sup>2</sup>
Re	7.6	ohm	BL	4.7	N/A
Le@1kHz	-	mH	Vas	5.95	ltrs
fs	80	Hz	Xmax	0.35	mm peak
Qms	2.56		VC Ø	20	mm
Qes	0.45		Sensitivity		
Qts	0.38		1W / 1m	90	dB
Mms	2.6	g	<b>Nom. Power</b>	<b>15</b>	<b>W</b>
Cms	0.0017	mm/N	Net weight	550	g

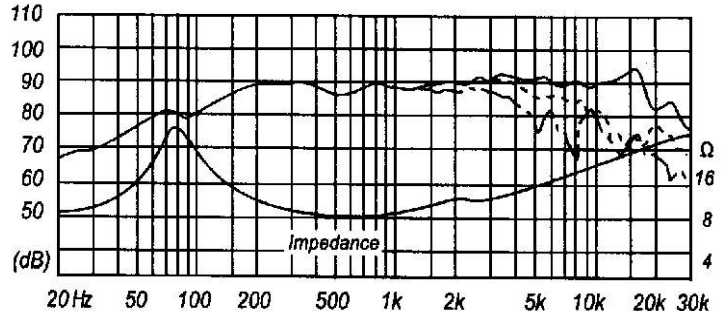
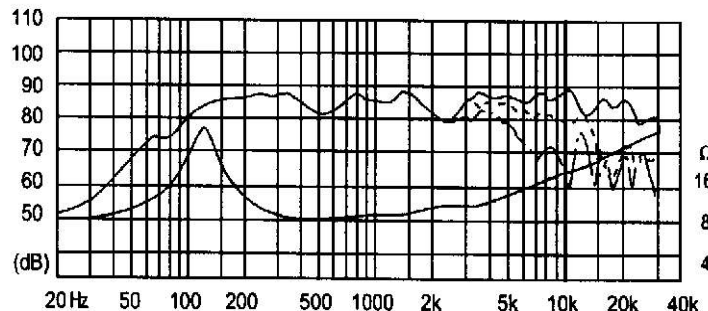

## FE126E \$35.50



**Fostex**

- 4.5" FULL RANGE
- ES banana pulp cone
- New center cap
- 93 db sensitivity
- Frequency response from 70 Hz to 25kHz
- Flange 117mm
- Cut-out 103mm
- Depth 61mm

Znom	8	ohm
Re	6.9	ohm
Le@1kHz	0.0065	mH
fs	70	Hz
Qms	2.96	
Qes	0.27	
Qts	0.25	
Mms	2.9	g
Cms	0.0017	mm/N

Sd	0.0065	m <sup>2</sup>
BL	5.92	N/A
Vas	9.95	ltrs
Xmax	0.35	mm peak
VC Ø	20	mm
Sensitivity		
1W / 1m	93	dB
<b>Nom. Power</b>	<b>45</b>	<b>W</b>
Net weight	1010	g

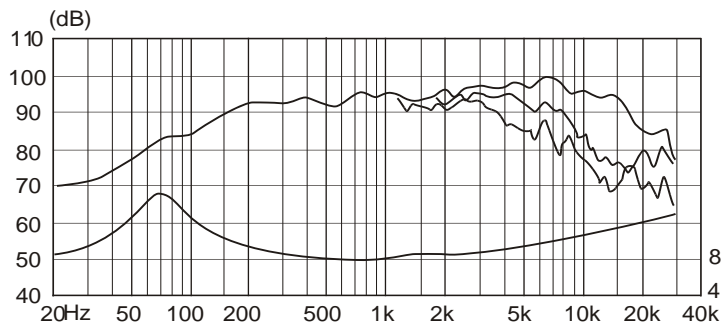

## FE127E \$36.50



**Fostex**

- 4.5" SHIELDED FULL RANGE
- ES banana pulp cone
- New center cap
- 91 db sensitivity
- Frequency response from 70.4 Hz to 20kHz
- Flange 117mm
- Cut-out 103mm
- Depth 64.7mm

Znom	8	ohm
Re	6.5	ohm
Le@1kHz	-	mH
fs	70.4	Hz
Qms	3.33	
Qes	0.50	
Qts	0.43	
Mms	6.85	g
Cms	0.0016	mm/N

Sd	0.0067	m <sup>2</sup>
BL	4.14	N/A
Vas	9.9	ltrs
Xmax	0.67	mm peak
VC Ø	20	mm
Sensitivity		
1W / 1m	91	dB
<b>Nom. Power</b>	<b>45</b>	<b>W</b>
Net weight	574	g

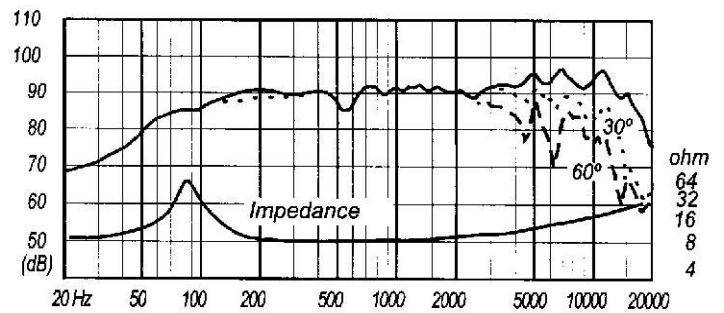

## FE166E \$61.05



**Fostex**

- 6" FULL RANGE
- ES banana pulp cone
- New center cap
- 8 ohm impedance
- 94 db sensitivity
- Frequency response from 50 Hz to 22kHz
- Flange 166mm
- Cut-out 144mm
- Depth 73.2mm

Znom	8	ohm
Re	7.1	ohm
Le@1kHz	-	mH
fs	50	Hz
Qms	3.89	
Qes	0.22	
Qts	0.21	
Mms	6.85	g
Cms	0.0018	mm/N

Sd	0.0132	m <sup>2</sup>
BL	8.33	N/A
Vas	45.11	ltrs
Xmax	0.6	mm peak
VC Ø	25	mm
Sensitivity		
1W / 1m	94	dB
<b>Nom. Power</b>	<b>65</b>	<b>W</b>
Net weight	1600	g

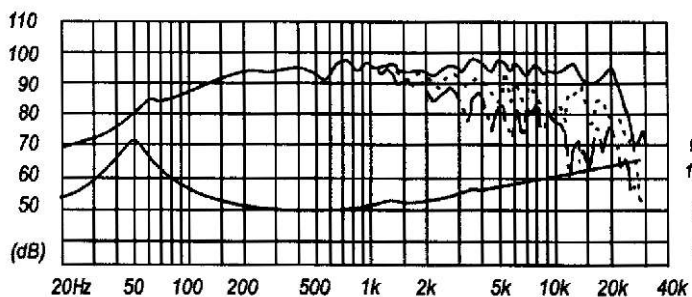

## FE167E \$63.25



**Fostex**

- 6" SHIELDED FULL RANGE
- ES banana pulp cone
- New center cap
- 8 ohm impedance
- Frequency response from 51.5 Hz to 22 kHz
- Flange 166 mm
- Cut-out 144 mm
- Depth 85 mm

Znom	8	ohm
Re	7.1	ohm
Le@1kHz	-	mH
fs	51.5	Hz
Qms	4.63	
Qes	0.33	
Qts	0.31	
Mms	6.68	g
Cms	0.0015	mm/N

Sd	0.0132	m <sup>2</sup>
BL	6.82	N/A
Vas	35.94	ltrs
Xmax	0.6	mm peak
VC Ø	25	mm
Sensitivity		
1W / 1m	94	dB
<b>Nom. Power</b>	<b>65</b>	<b>W</b>
Net weight	1320	g

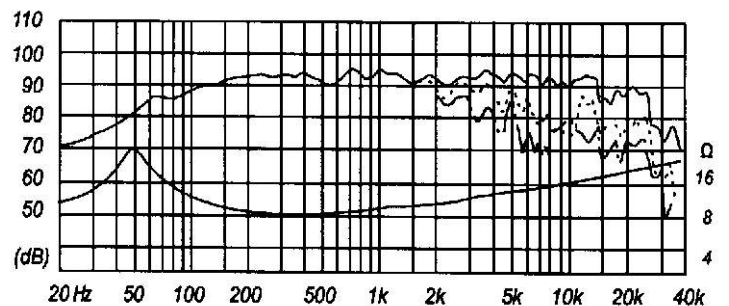



**FE206E \$84.30**



- 8" FULL RANGE
- ES banana pulp cone
- New center cap
- Large 110mm magnet
- Frequency response from 39 Hz to 20kHz
- Flange 208 mm
- Cut-out 182 mm
- Depth 87.5 mm

**Fostex**

Znom	8	ohm	Sd	0.0206	m <sup>2</sup>
Re	6.69	ohm	BL	11.8	N/A
Le@1kHz	-	mH	Vas	54.53	ltrs
fs	39	Hz	Xmax	1.5	mm peak
Qms	3.73		VC Ø	35	mm
Qes	0.18		Sensitivity		
Qts	0.18		1W / 1m	96	dB
Mms	15.35	g	<b>Nom. Power</b>	<b>90</b>	<b>W</b>
Cms	0.0009	mm/N	Net weight	3350	g

**FE207E \$86.50**



- 8" SHIELDED FULL RANGE
- ES banana pulp cone
- New center cap
- 8 ohm impedance
- Frequency response from 39kHz to 20kHz
- Flange 208 mm
- Cut-out 182 mm
- Depth 104 mm

**Fostex**

Znom	8	ohm	Sd	0.0206	m <sup>2</sup>
Re	6.73	ohm	BL	9.41	N/A
Le@1kHz	-	mH	Vas	56.25	ltrs
fs	39	Hz	Xmax	1.5	mm peak
Qms	3.86		VC Ø	35	mm
Qes	.28		Sensitivity		
Qts	.26		1W / 1m	95	dB
Mms	15.02	g	<b>Nom. Power</b>	<b>90</b>	<b>W</b>
Cms	0.0009	mm/N	Net weight	2650	g

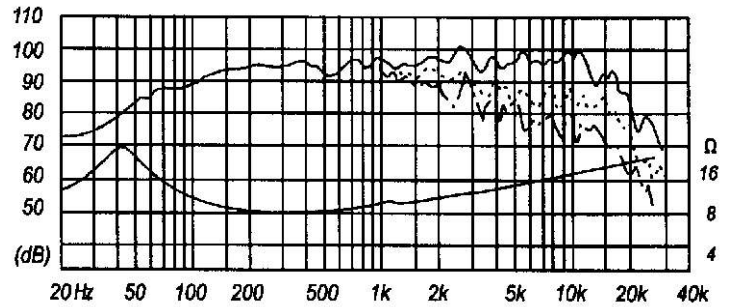
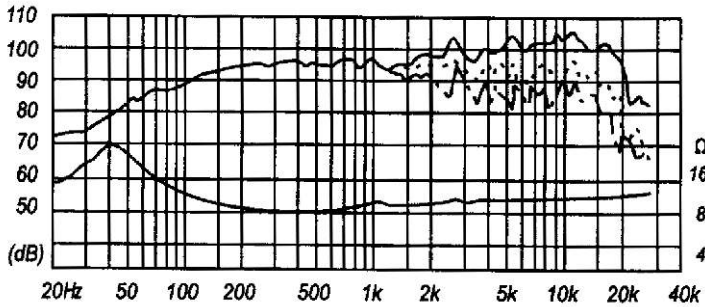

**FF85K \$32.15**



- 3" FULL RANGE
- KENAF paper/ fiber composite cone
- UDR surround
- Aluminum center cap
- Frequency response from 122 Hz to 32 kHz
- Flange 83 mm
- Cut-out 71 mm
- Depth 49 mm

**Fostex**

Znom	8	ohm	Sd	0.0028	m <sup>2</sup>
Re	7.08	ohm	BL	4.33	N/A
Le@1kHz	-	mH	Vas	1.07	ltrs
fs	122	Hz	Xmax	0.55	mm peak
Qms	5.54		VC Ø	20	mm
Qes	0.52		Sensitivity		
Qts	0.47		1W / 1m	88	dB
Mms	1.8	g	<b>Nom. Power</b>	<b>10</b>	<b>W</b>
Cms	0.001	mm/N	Net weight	565	g

**FF125K \$40.00**



- 4.5" FULL RANGE
- KENAF paper/ fiber composite cone
- 92db sensitivity
- Frequency response from 72 Hz to 18 kHz
- Flange 117 mm
- Cut-out 103 mm
- Depth 60.1 mm

**Fostex**

Znom	8	ohm	Sd	-	cm <sup>2</sup>
Re	7.2	ohm	BL	-	N/A
Le@1kHz	-	mH	Vas	9.12	ltrs
fs	72	Hz	Xmax	0.15	mm peak
Qms	9.04		VC Ø	-	mm
Qes	0.27		Sensitivity		
Qts	0.26		1W / 1m	92	dB
Mms	4.0	g	<b>Nom. Power</b>	<b>50</b>	<b>W</b>
Cms	-	mm/N	Net weight	930	g

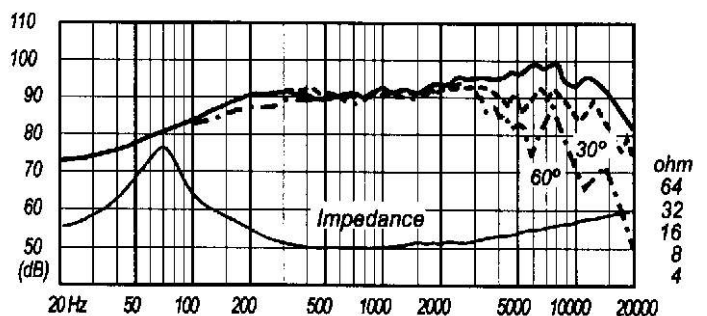
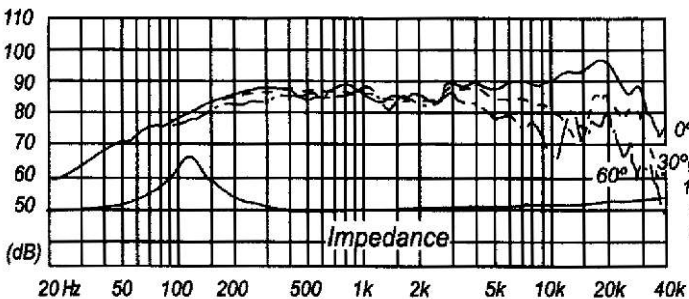

## FF165K \$61.10



**Fostex**

- 6.5" FULL RANGE
- KENAF paper/ fiber composite cone
- Foam surround
- 94db sensitivity
- Frequency response from 40 Hz to 17 kHz
- Flange 166 mm
- Cut-out 144 mm
- Depth 73.7 mm

Znom	8	ohm
Re	7.4	ohm
Le@1kHz	-	mH
fs	40	Hz
Qms	10.92	
Qes	0.21	
Qts	0.20	
Mms	7.8	g
Cms	-	mm/N

Sd	-	cm <sup>2</sup>
BL	-	N/A
Vas	48.2	ltrs
Xmax	0.3	mm peak
VC Ø	-	mm
Sensitivity		
1W / 1m	94	dB
<b>Nom. Power</b>	<b>70</b>	<b>W</b>
Net weight	1.6	kg

## FF225K \$94.35



**Fostex**

- 8" FULL RANGE
- KENAF paper/ fiber composite cone
- Foam surround
- 96 db sensitivity
- Frequency response from 38 Hz to 14 kHz
- Flange 208 mm
- Cut-out 182 mm
- Depth 93 mm

Znom	8	ohm
Re	6.3	ohm
Le@1kHz	-	mH
fs	38	Hz
Qms	3.06	
Qes	0.17	
Qts	0.16	
Mms	17.3	g
Cms	-	mm/N

Sd	-	cm <sup>2</sup>
BL	-	N/A
Vas	79.41	ltrs
Xmax	0.3	mm peak
VC Ø	-	mm
Sensitivity		
1W / 1m	96	dB
<b>Nom. Power</b>	<b>100</b>	<b>W</b>
Net weight	3.72	kg

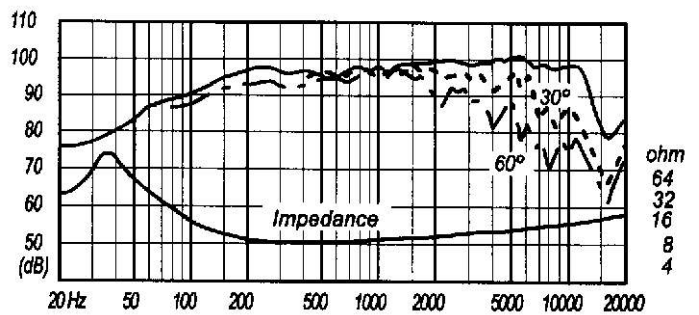
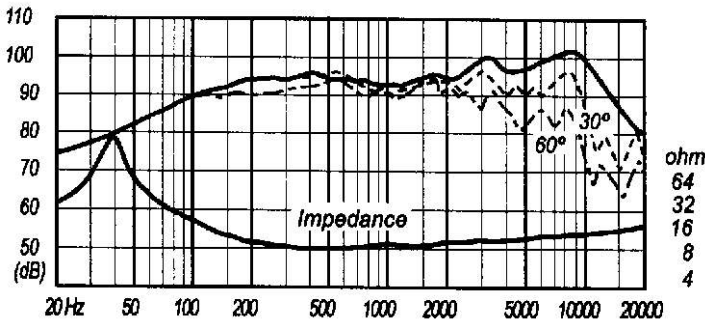

## FW137 \$55.70



**Fostex**

- 5.5" SHIELDED WOOFER
- Kenaf-Cellgaia Paper Cone
- 87 db sensitivity
- Frequency response from 55 Hz to 8 kHz
- Flange 155 mm
- Cut-out 121 mm
- Depth 77 mm

Znom	8	ohm
Re	7.4	ohm
Le@1kHz	0.07	mH
fs	55	Hz
Qms	3.58	
Qes	0.57	
Qts	0.50	
Mms	11.7	g
Cms	0.0008	mm/N

Sd	0.0095	m <sup>2</sup>
BL	7.06	N/A
Vas	10.2	ltrs
Xmax	1	mm peak
VC Ø	30.4	mm
Sensitivity		
1W / 1m	87	dB
<b>Nom. Power</b>	<b>75</b>	<b>W</b>
Net weight	1.49	kg

## FW167 \$83.65



**Fostex**

- 6.5" SHIELDED WOOFER
- Kenaf-Cellgaia Paper cone
- 89 db sensitivity
- Frequency response from 40 Hz to 6 kHz
- Flange 186 mm
- Cut-out 143 mm
- Depth 96.2 mm

Znom	8	ohm
Re	7.1	ohm
Le@1kHz	.071	mH
fs	40	Hz
Qms	2.6	
Qes	0.40	
Qts	0.36	
Mms	14.9	g
Cms	0.0011	mm/N

Sd	0.0128	cm <sup>2</sup>
BL	8.2	N/A
Vas	25.22	ltrs
Xmax	1.5	mm peak
VC Ø	35.5	mm
Sensitivity		
1W / 1m	89	dB
<b>Nom. Power</b>	<b>100</b>	<b>W</b>
Net weight	2.66	kg

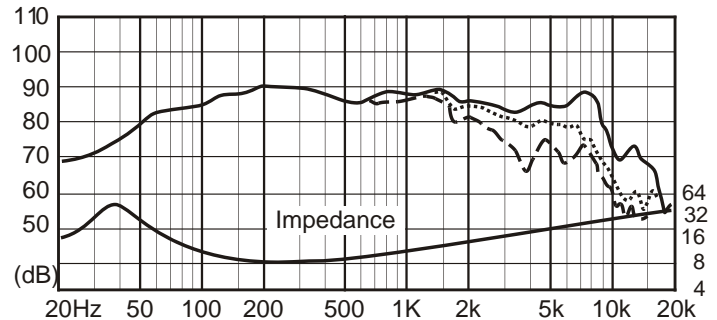
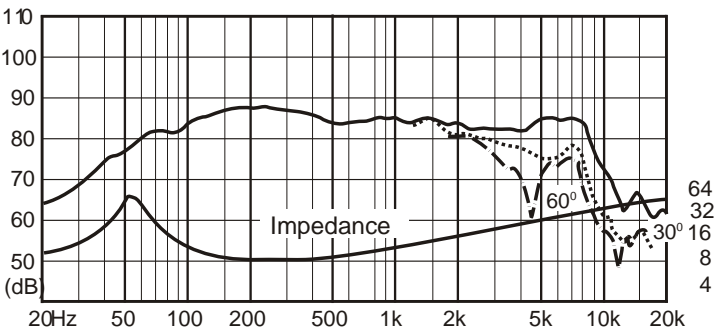



### FW168HP \$230.00



- 7" HP CONE FULL RANGE
- ES banana pulp cone
- UDR surround
- Frequency response from 55kHz to 10kHz
- Flange 190 mm
- Cut-out 146 mm
- Depth 96 mm

**Fostex**

Znom	8	ohm	Sd	0.011	cm <sup>2</sup>
Re	5.8	ohm	BL	-	N/A
Le@1kHz	-	mH	Vas	9.87	ltrs
fs	55	Hz	Xmax	1.0	mm peak
Qms	2.86		VC Ø	35	mm
Qes	0.23		Sensitivity		
Qts	0.22		1W / 1m	90	dB
Mms	19.5	g	<b>Nom. Power</b>	<b>100</b>	<b>W</b>
Cms	-	mm/N	Net weight	3.5	kg

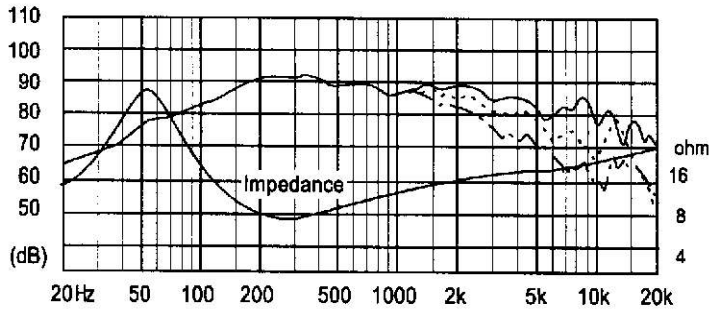

### FW168HP-X \$230.00



- 7" HP CONE FULL RANGE
- ES banana pulp cone
- UDR surround
- Frequency response from 70kHz to 10kHz
- Flange 190 mm
- Cut-out 146 mm
- Depth 96 mm

**Fostex**

Znom	8	ohm	Sd	0.011	cm <sup>2</sup>
Re	7.1	ohm	BL	8.54	N/A
Le@1kHz	0.05	mH	Vas	5.84	ltrs
fs	70	Hz	Xmax	2.7	mm peak
Qms	3.09		VC Ø	35	mm
Qes	0.65		Sensitivity		
Qts	0.53		1W / 1m	88	dB
Mms	15.2	g	<b>Nom. Power</b>	<b>100</b>	<b>W</b>
Cms	0.00034	mm/N	Net weight	3.55	kg

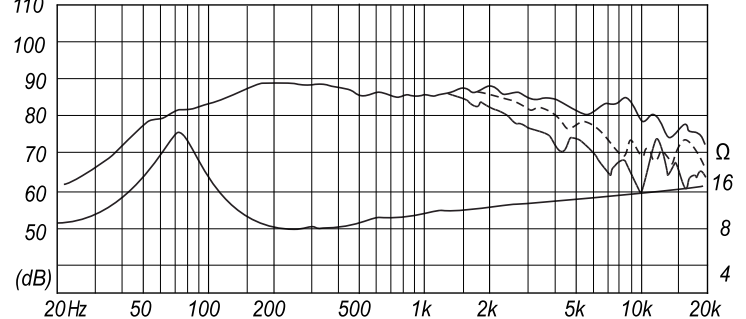

### FW108N \$108.25



- 4" FULL RANGE
- Hybrid pulp cone
- 8 ohm impedance
- 86 db sensitivity
- Frequency response from 55 Hz to 10 kHz
- Flange 128 mm
- Cut-out 100 mm
- Depth 72 mm

**Fostex**

Znom	8	ohm	Sd	-	cm <sup>2</sup>
Re	6.3	ohm	BL	-	N/A
Le@1kHz	-	mH	Vas	4.09	ltrs
fs	55	Hz	Xmax	1.9	mm peak
Qms	8.8		VC Ø	-	mm
Qes	0.27		Sensitivity		
Qts	0.26		1W / 1m	86	dB
Mms	6.9	g	<b>Nom. Power</b>	<b>50</b>	<b>W</b>
Cms	-	mm/N	Net weight	1.69	kg

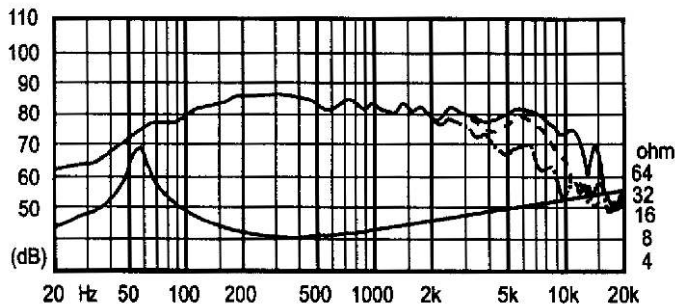

### FW208N \$160.50



- 8" WOOFER
- Hybrid pulp cone
- 8 ohm impedance
- 90db sensitivity
- Frequency response from 29 Hz to 5 kHz
- Flange 230 mm
- Cut-out 182 mm
- Depth 94.8 mm

**Fostex**

Znom	8	ohm	Sd	-	cm <sup>2</sup>
Re	5.8	ohm	BL	-	N/A
Le@1kHz	-	mH	Vas	43.4	ltrs
fs	29	Hz	Xmax	6.5	mm peak
Qms	13.2		VC Ø	81	mm
Qes	0.21		Sensitivity		
Qts	0.20		1W / 1m	90	dB
Mms	40	g	<b>Nom. Power</b>	<b>100</b>	<b>W</b>
Cms	-	mm/N	Net weight	4.62	kg

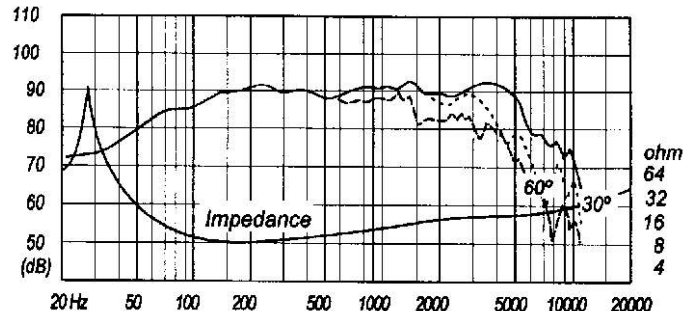

**FW800N \$2,446.00**

- 31.5" SUPER WOOFER
- Hybrid pulp cone
- 96db sensitivity
- 8 ohm impedance
- Frequency response from 18 Hz to 1.5 kHz
- Flange 800mm
- Cut-out 748mm
- Depth 291mm



Znom	8	ohm	Sd	-	cm <sup>2</sup>
Re	6.8	ohm	BL	-	N/A
Le@1kHz	-	mH	Vas	3201.1	ltrs
fs	18	Hz	Xmax	2.3	mm peak
Qms	8.5		VC Ø		mm
Qes	0.76		Sensitivity		
Qts	0.69		1W / 1m	96	dB
Mms	440	g	<b>Nom. Power</b>	<b>450</b>	<b>W</b>
Cms	-	mm/N	Net weight	20.7	kg

**D1405 \$262.80**

- Compression Driver
- Alnico magnet
- Titanium diaphragm
- Frequency response from 850 Hz to 20kHz
- 1" throat diameter
- 8 ohm
- fs 850Hz
- 104dB (without horn)
- 60W
- 3.527 pounds



You can use this horn with the Fostex H400 wooden horn or with another horn of your choosing.

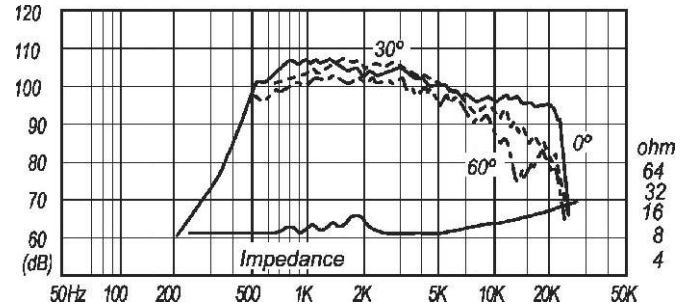
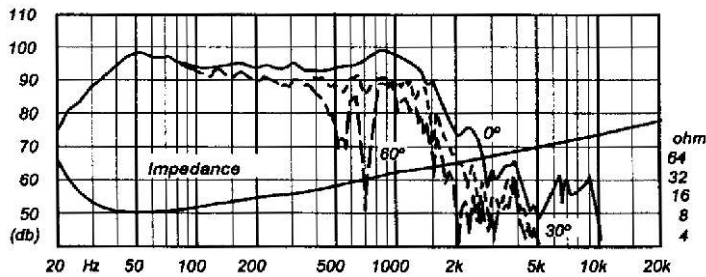

**R80B \$21.10**

- 8 ohm Attenuator
- Attenuation 0 to 40 db or more
- Input 100 watts
- Flange 50 x 50 mm SQUARE
- Depth 71 mm



**R82B \$36.75**

- 8 ohm Attenuator
- Attenuation 0 to 40 db or more
- Input 200 watts
- Flange 50 x 50 mm SQUARE
- Depth 89 mm



**R100T \$170.90**

- Transformer type Attenuator
- Attenuation 0 to 21 db (1 db step)
- Input 100 watts
- Flange 88mm x 90mm
- Depth 170mm



**H400** Wooden Horn and **D1405** Horn Driver. Cutoff frequency of H400 is 455Hz, 1" throat.  
Dimensions: 15.59" W x 4.72" T x 8.9" D - Natural Maple  
**H400 Horn is \$470.20 each (driver not included).**

*Cabinet plans available on our website.  
[www.madisound.com/fostex.html](http://www.madisound.com/fostex.html)*



# Fostex Professional Audio



**Horn Tweeter  
100HT  
\$37.60 each**



**Horn Tweeter  
400HT  
\$87.40 each**

## 3" x 4" High Frequency Compression Driver ABS Plastic Horn, Phenolic Resin Diaphragm

Usable Frequency Range : 5000 - 20000 Hz  
 Power Rating : 100 Watts  
 Average Sensitivity (1w/1m) : 102 dB  
 Impedance : 8 ohm  
 Width 4.4", Height 3.54", Depth 3.5", Flange thickness 0.16"

## 4" x 10" High Frequency Compression Driver Cast Aluminum Horn, Phenolic Resin Diaphragm

Usable Frequency Range : 3000 - 14000 Hz  
 Power Rating : 120 Watts  
 Average Sensitivity (1w/1m) : 108 dB  
 Impedance : 8 ohm  
 Width 10.58", Height 4.32", Depth 7.46", Flange thickness 0.1"

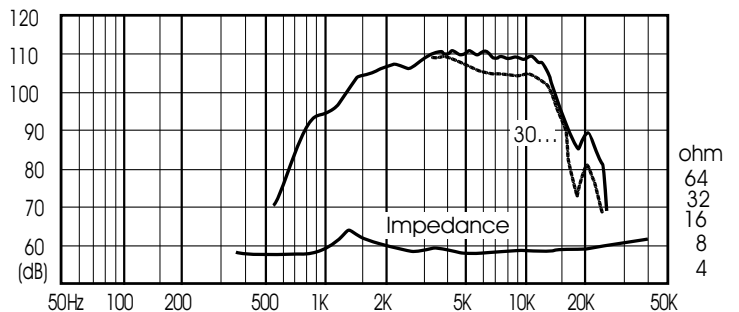
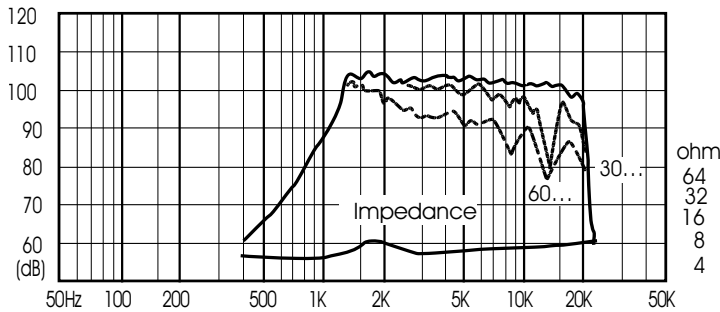

PS100 - 4"

**Fostex PS100 4" Wide Band \$42.20**

Fs	200 Hz	Mms	1.66 gr
Impedance	8 ohm	Qms	4.56
Efficiency	92 dB	Qes	1.03
Power	25 W	Qts	0.84
X-max	0.5 mm	Vas	1.3 ltrs
Voice coil Ø	1"	Overall diameter	105mm
Magnet weight	6.8 oz	Cut-out diameter	92mm
Re	6.8 ohm	Depth	44mm

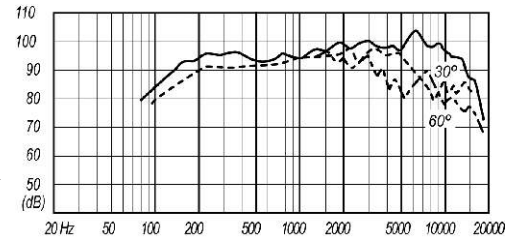

PS200 - 8"

**Fostex PS200 8" Wide Band \$86.55**

Fs	100 Hz	Mms	11 gr
Impedance	8 ohm	Qms	10.72
Efficiency	96 dB	Qes	0.94
Power	40 W	Qts	0.94
X-max	1.3 mm	Vas	17.3 ltrs
Voice coil Ø	1.5"	Overall diameter	210mm
Magnet weight	30 oz	Cut-out diameter	182mm
Re	6.7 ohm	Depth	86mm

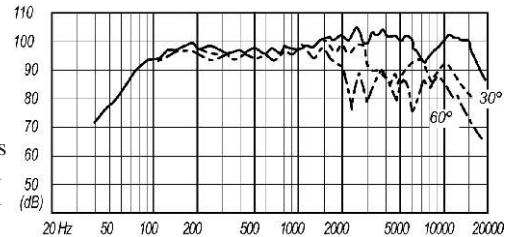

PS300 - 12"

**Fostex PS300 12" Wide Band \$165.25**

Fs	58 Hz	Mms	35 gr
Impedance	8 ohm	Qms	10.99
Efficiency	98 dB	Qes	0.93
Power	75 W	Qts	0.86
X-max	1.9 mm	Vas	102 ltrs
Voice coil Ø	2"	Overall diameter	312mm
Magnet weight	50 oz	Cut-out diameter	272mm
Re	7.2 ohm	Depth	122mm

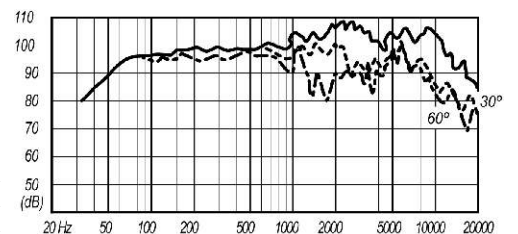



# Fountek NeoCd3.0M 3" Ribbon

Ribbon Material	Aluminum Alloy
Ribbon Mass	18 mg
Ribbon dimension	8mm x 60mm x 0.02mm
Impedance	7 ohm
Frequency Response	1,400Hz ~ 40,000Hz
Sensitivity	95dB/2.83V/m
Power Handling	17W nominal 40W max
Suggested x-over frequency	2500Hz @ 12dB
Weight	560g / 1.28lb
<b>Price Each</b>	<b>\$89.00</b>



SPL vs Freq

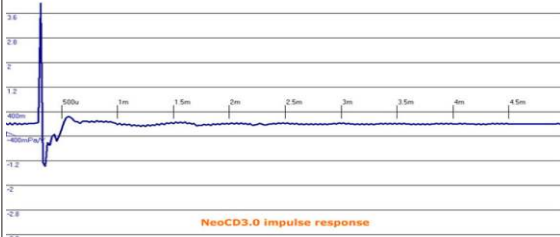
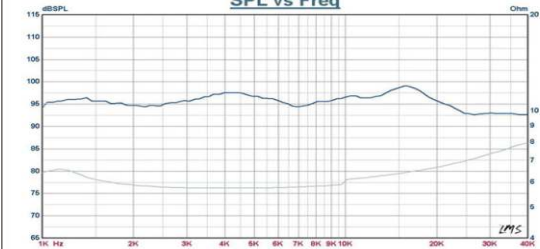

NeoCd3.0 impulse response

## Features:

- Black metal face plate
- Aluminum Alloy ribbon.
- Super strong Neodymium magnet
- Frequency range from 1400Hz to over 40kHz
- Extremely thin foil (0.02mm) for a high degree of signal fidelity and broad frequency response.
- Low distortion and high power handling
- Flat impedance response

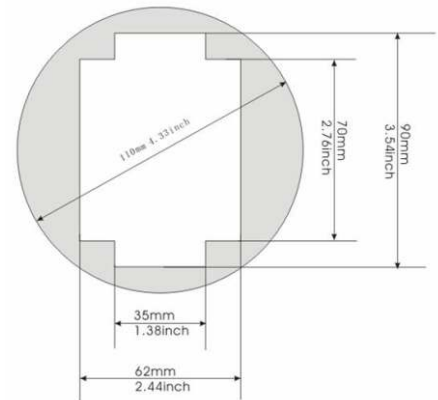

# Fountek NeoCd2.0M 5" Ribbon

Ribbon Material	Aluminum Alloy
Ribbon Mass	34 mg
Ribbon dimension	8mm x 120mm x 0.02mm
Impedance	7 ohm
Frequency Response	1,200Hz ~ 40,000Hz
Sensitivity	98dB/2.83V/m
Power Handling	20W nominal 50W max
Suggested x-over frequency	2000Hz @ 12dB
Weight	1065g / 2.35lb
<b>Price Each</b>	<b>\$126.00</b>

SPL vs Freq

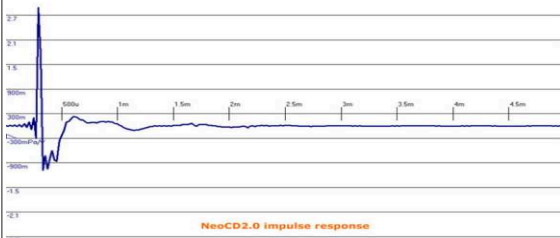
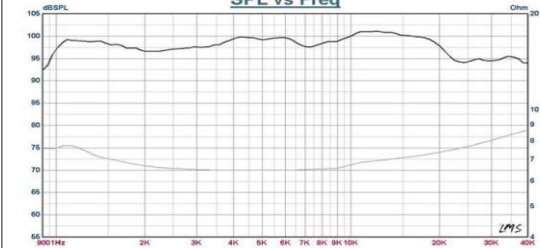

NeoCd2.0 impulse response

## Features:

- Black metal face plate
- Aluminum Alloy ribbon.
- Super strong Neodymium magnet for high efficiency.
- Built-in impedance conversion transformer.
- Frequency range from 1200Hz to over 40kHz
- Extremely thin foil (0.02mm) for a high degree of signal fidelity and broad frequency response.
- Low distortion and high power handling.
- Flat impedance response

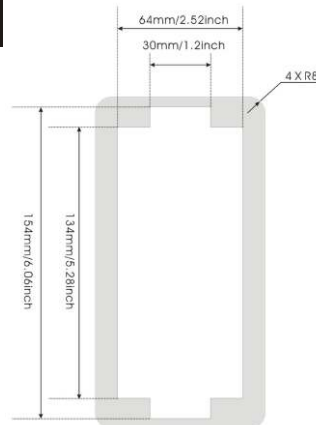

## Warning:

The ribbon tweeters should always be used with a passive crossover!

Do not test without a capacitor.

Tweeters are repairable at Madisound.

Also available, the larger **Pro Sound** version **NeoPro5i**, see out web site for details. \$305 ea



# Hi-Vi Research Loudspeakers



For complete specifications: [www.swanspeaker.com](http://www.swanspeaker.com)

Model (width x height)	Imp. W	Fs Hz	Qts	Vas Ltrs	Power Watts	dB	Frequency Range	VC Ø mm	Rec. Box Liters S / V	F3 Hz S / V	Price Each
<b>Isodynamic Ribbon Tweeters</b>											
<b>RT1L</b> 110mm circular ribbon	4	-	-	-	5	88	3.5k-40kHz		Neodymium magnet		<b>\$39.75</b>
<b>RT1.3</b> 88mm x 102mm flange	6	-	-	-	10	92	2.5k-30kHz		Neodymium magnet		<b>\$42.75</b>
<b>RT1C-A</b> 120mm round flange	5	-	-	-	15	94	4.5k-23kHz		Neodymium magnet		<b>\$49.30</b>
<b>RT2II</b> 145mm x 166mm rectangular flange	8	-	-	-	30	93	2k-27kHz		Neodymium magnet		<b>\$92.00</b>
<b>RT2C-A</b> 176mm round flange	8	-	-	-	30	93	3k-40kHz		Neodymium magnet		<b>\$85.45</b>
<b>RT2E-A</b> 105mm x 176mm ovalish flange	8	-	-	-	30	93	3k-40kHz		Neodymium magnet		<b>\$85.45</b>
<b>RT2-Pro</b> 220mm x 166mm rectangular flange	8	-	-	-	30	99	2.3k-35kHz		Neodymium magnet		<b>\$180.70</b>
<b>RT8II</b> 160mm x 220mm rectangular flange	8	-	-	-	30	95	1.7k-27kHz		Neodymium magnet		<b>\$115.00</b>
<b>1" Fabric Dome Tweeters</b>											
<b>SD1.1-A</b> 116mm round flange, shielded	5	1200	-	-	15	91	3k-20kHz	25	Shielded magnet		<b>\$12.50</b>
<b>Q1R</b> 116mm round flange, shielded	6	1000	-	-	15	89	2.5k-20kHz	28	Shielded magnet		<b>\$14.80</b>
<b>TN28</b> 46mm Ø x 99mm Top Mount	6	1300	-	-	15	90	3k-25kHz	28	Top mount, shielded		<b>\$13.15</b>
<b>TN25</b> 54.5mm square with chamber	5	1500	-	-	15	90	3k-21kHz	25	Small flange, shielded		<b>\$8.25</b>
<b>K1</b> 116mm round aluminum flange, shielded	5	800	-	-	15	92	2.5k-25kHz	25	Aluminum face plate		<b>\$8.55</b>
<b>X1R</b> 116mm round flange, ferrofluid cooled	4	1600	-	-	15	91	3k-20kHz	25	decorative face plate		<b>\$8.55</b>
<b>2" Fabric Dome Midranges</b>											
<b>TM1A</b> Tweeter/Midrange combo plate	6/5	-	-	-	60	93	1kHz-20kHz	28/50	Rec x-over 2.5 to 4kHz		<b>\$36.15</b>
<b>DMN-A</b> 116mm round flange with chamber	5	800	-	-	60	93	1kHz-10kHz	50	117mm deep bullet ch.		<b>\$26.30</b>
<b>DMB-A</b> 145mm round flange, shielded	5	700	-	-	80	92	800Hz-10kHz	50	43mm D., rough dome		<b>\$23.70</b>
<b>Small Full Range Speakers, Shielded, Metal Alloy Cones</b>											
<b>A2S</b> 53mm square flange, shielded, silver color	8	153	1.27	0.2	10	78	150Hz-15kHz	25	0.5 - 2	150	<b>\$10.20</b>
<b>B2S</b> 53mm square flange, shielded, copper color	8	152	1.2	0.2	10	78	150Hz-15kHz	25	0.5 - 2	150	<b>\$10.85</b>
<b>U2S</b> 53mm square flange, shielded, aluminum	8	290	1.12	0.1	5	83	245Hz-20kHz	25	0.5 - ~	245	<b>\$10.20</b>
<b>B3S</b> 78mm square flange, shielded, copper color	8	80	0.93	1.6	15	80	80Hz-8kHz	20	0.5 - 2	80	<b>\$9.55</b>
<b>B3N</b> 90mm round flange, shielded, copper color	8	77	0.86	1.7	15	81	80Hz-8kHz	20	0.5 - 2	80	<b>\$9.55</b>
<b>M3S</b> 78mm square flange, shielded, copper color	8	90	0.88	1.2	15	81	90Hz-6kHz	20	0.75 - 3	100	<b>\$14.80</b>
<b>"D" Series Mineral Filled Polypropylene Cones, Large Diameter Voice Coils</b>											
<b>D6.8</b> 174mm round flange, cast frame	8	42	0.40	13.5	60	85	40Hz-4kHz	76	7 / 12	74 / 42	<b>\$62.75</b>
<b>D8.8</b> 243mm round flange, cast frame	8	30	0.38	46.8	150	87	30Hz-2kHz	100	18 / 31	57 / 34	<b>\$87.75</b>
<b>D10.8</b> 299mm round flange, cast frame	8	20	0.40	211.1	150	87	35Hz-500Hz	100	90 / -	35 / -	<b>\$104.15</b>
<b>"F" Series Kevlar/Paper Cones, Cast Frames, Shielded Magnets, Yellow Cones</b>											
<b>F5</b> 154mm round flange, phase plug	8	52	0.33	7.3	35	86	65Hz-8kHz	25	2 / 4	111 / 63	<b>\$36.15</b>
<b>F6</b> 197mm round flange, phase plug	8	45	0.35	16.4	45	88	50Hz-5kHz	25	5 / 11	92 / 51	<b>\$45.65</b>
<b>F8</b> 217mm round flange	8	36	0.39	36.9	60	87	38Hz-3kHz	35	17 / 30	65 / 38	<b>\$65.40</b>
<b>"M" Series Magnesium/Aluminum Alloy Cones, Copper Color Cones</b>											
<b>M5N</b> 144mm round flange, shielded magnet	8	47	0.35	11.3	35	87	53Hz-5kHz	25	3.5 / 6	95 / 59	<b>\$28.30</b>
<b>M5a</b> 140mm round flange, shielded magnet	8	48	0.34	11.2	35	87	65Hz-3kHz	25	3 / 5	100 / 63	<b>\$33.85</b>
<b>M6a</b> 174mm round flange, shielded magnet	8	46	0.38	13.6	45	88	50Hz-3kHz	25	9 / 14	86 / 53	<b>\$44.35</b>
<b>M8a</b> 215mm round flange	8	30	0.43	50.3	80	87	30Hz-2kHz	35	29 / 40	49 / 32	<b>\$58.50</b>
<b>M12</b> 313mm round flange	4	27	0.33	81.4	150	93	30Hz-1.5kHz	50	24 / 53	57 / 32	<b>\$131.75</b>
<b>Various Polymer Cone speakers</b>											
<b>W5</b> 153mm round flange, shielded, phase plug	8	57	0.49	8.6	35	86	50Hz-7kHz	25	8 / 9	82 / 52	<b>\$35.80</b>
<b>W6</b> 179mm round flange, shielded	8	40	0.52	25.1	45	86	55Hz-3kHz	25	15 / -	55 / -	<b>\$44.70</b>
<b>SP10</b> 246mm round flange, subwoofer	4	34	0.57	17.1	500	84	40Hz-500Hz	76	32	40	<b>\$170.85</b>



## SP10 Subwoofer

- 10" Subwoofer with double layer mica film cone
- Large roll rubber surround
- 261mm flange, 236mm cut out and 145mm depth
- For Home or Autosound applications

**For Home:** 25Hz in 1.1 cubic foot sealed with KG5230.

**For Car:** 15Hz in 1.1 cubic foot sealed box (with +6dB of cabin gain)

Znom	4	ohm	Sd	363	cm <sup>2</sup>
fs	34	Hz	BL	16.6	Tm
Nom. Power	500	W	Vas	17.1	ltrs
Re	3.4	ohm	Xmax	15.5	mm pk
Qms	4.83		VC Ø	76	mm
Qes	0.65		Sensitivity		
Qts	0.57		2.83V / 1m	84	dB
Mms	235	g	Weight	13.0	kg
Cms	91.4	µm/N	Rec. Box: 30 liters sealed		

## RT1L Circular Ribbon

- 110mm Round flange
- Frequency range 3.5k-40kHz
- Isodynamic Ribbon
- Neodymium magnet
- Magnetically shielded
- Flat impedance curve



Znom	4 ohm
Nom. Power	5 Watts
Sensitivity	88 dB
2.83V / 1m	
Magnet System	Neodymium
Weight	0.8 kg

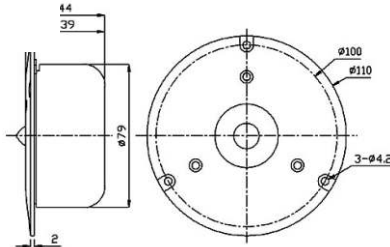

## RT1.3 Ribbon

- 88 x 102mm flange
- Frequency range 2.5k-30kHz
- Isodynamic Ribbon
- Neodymium magnet
- Magnetically shielded
- Flat Impedance curve



Znom	6 ohm
Nom. Power	10 Watts
Sensitivity	92 dB
2.83V / 1m	
Magnet System	Neodymium
Weight	0.2 kg

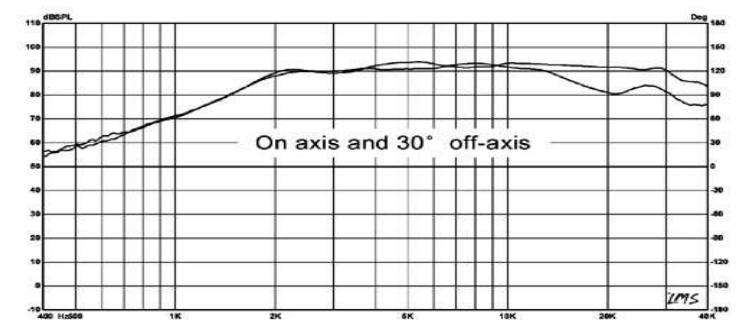
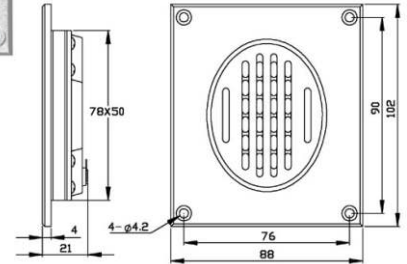

## RT1C-A Ribbon

- 120mm Round flange
- Frequency range 4.5k-23kHz
- Isodynamic Ribbon
- Neodymium magnet
- Magnetically shielded
- Flat impedance curve

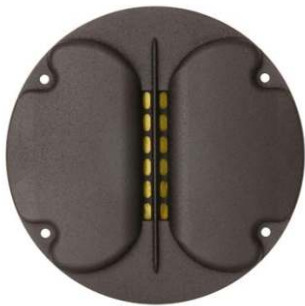

Znom	5 ohm
Nom. Power	15 Watts
Sensitivity	94 dB
2.83V / 1m	
Magnet System	Neodymium
Weight	0.2 kg

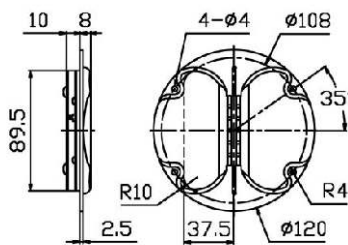

## RT2II Ribbon

- 160 x 186mm flange
- Frequency range 2k-27kHz
- Isodynamic Ribbon
- Neodymium magnet
- Magnetically shielded
- Flat Impedance curve



Znom	8 ohm
Nom. Power	30 Watts
Sensitivity	93 dB
2.83V / 1m	
Magnet System	Neodymium
Weight	0.87 kg

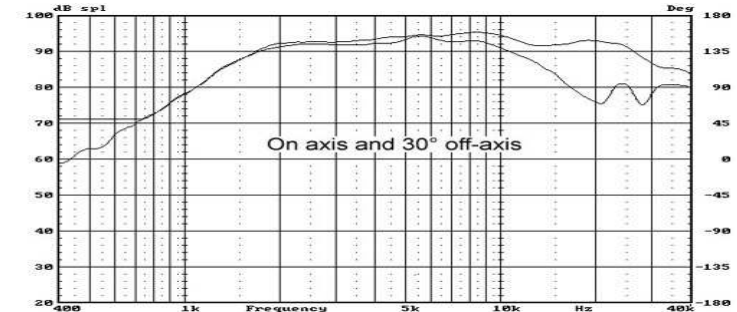
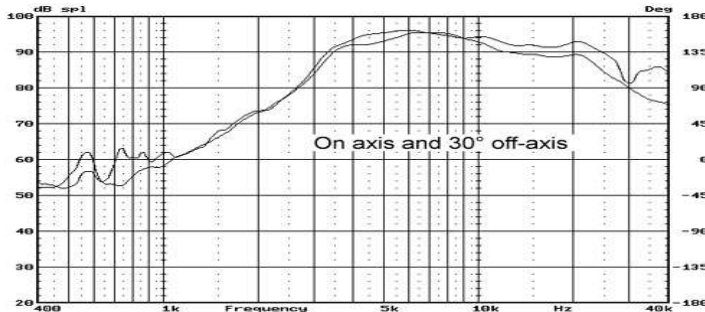
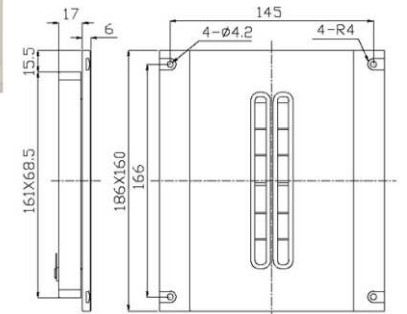



## RT2C-A Ribbon



- 176mm Round flange
- Frequency range 3k-40kHz
- Isodynamic Ribbon
- Neodymium magnet
- Magnetically shielded
- Flat Impedance curve

Znom 8 ohm  
 Nom. Power 30 Watts  
 Sensitivity 2.83V / 1m 93 dB  
 Magnet System Neodymium

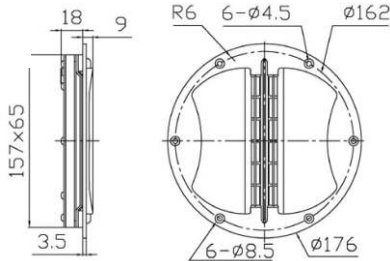

## RT2E-A Ribbon



- 105mm x 176mm flange
- Frequency range 3k-40kHz
- Isodynamic Ribbon
- Neodymium magnet
- Magnetically shielded
- Flat Impedance curve

Znom 8 ohm  
 Nom. Power 30 Watts  
 Sensitivity 2.83V / 1m 93 dB  
 Magnet System Neodymium

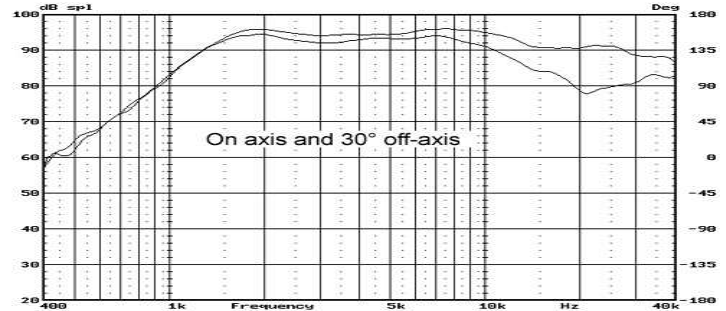
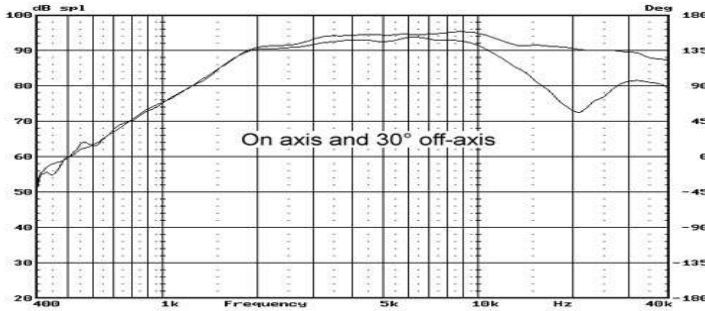
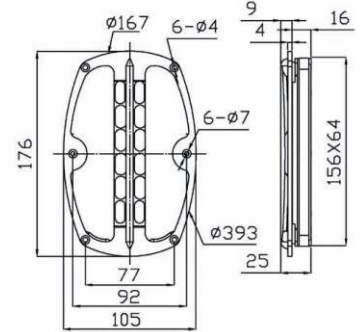

## RT2-Pro Ribbon

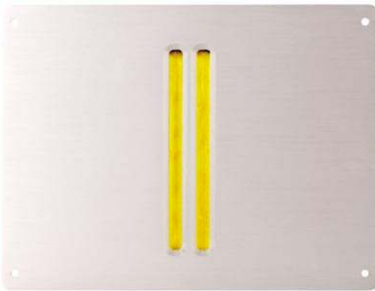

- 220 x 166mm flange
- Frequency range 2.3k-35kHz
- Isodynamic Ribbon
- Neodymium magnet
- Magnetically shielded
- Flat Impedance curve

Znom 8 ohm  
 Nom. Power 30 Watts  
 Sensitivity 2.83V / 1m 99 dB  
 Magnet System Neodymium  
 Weight 1.06 kg

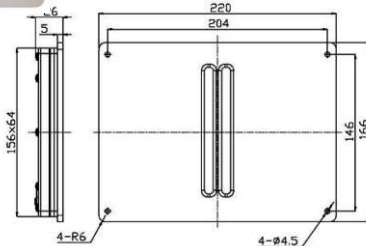

## RT8II Ribbon



- 160 x 220mm flange
- Frequency range 1.7k-27kHz
- Isodynamic Ribbon
- Neodymium magnet
- Magnetically shielded
- Flat Impedance curve

Znom 6 ohm  
 Nom. Power 30 Watts  
 Sensitivity 2.83V / 1m 95 dB  
 Magnet System Neodymium  
 Weight 1.1 kg

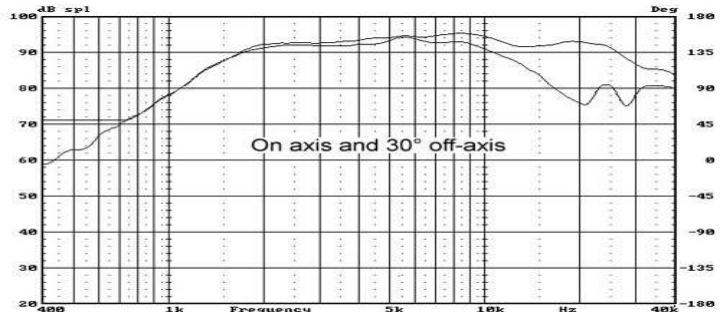
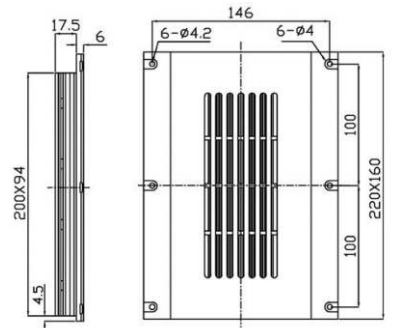

## SD1.1-A Tweeter



- Fabric dome tweeter
- 116mm flange
- Shielded magnet

Znom	5	ohm
fs	1200	Hz
Nom. Power	15	W
Re	4.6	ohm
VC Ø	25	mm
Sensitivity		
2.83V / 1m	91	dB
Weight	1.0	kg

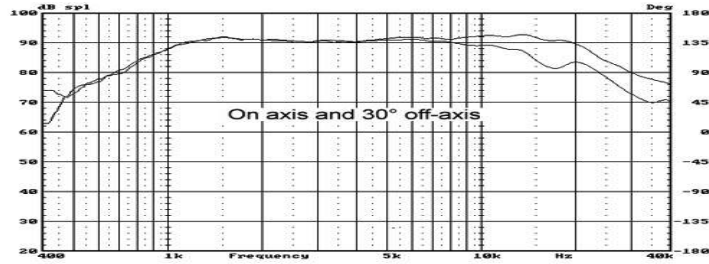

## Q1R Tweeter



- Fabric dome tweeter
- 116mm flange
- Shielded magnet

Znom	6	ohm
fs	1000	Hz
Nom. Power	89	W
Re	5.3	ohm
VC Ø	28	mm
Sensitivity		
2.83V / 1m	89	dB
Weight	0.8	kg



## TN28 Tweeter



- Top Mount
- Fabric dome tweeter
- Shielded magnet

Znom	6	ohm
fs	1300	Hz
Nom. Power	15	W
Re	5.1	ohm
VC Ø	28	mm
Sensitivity		
2.83V / 1m	90	dB
Weight	0.14	kg

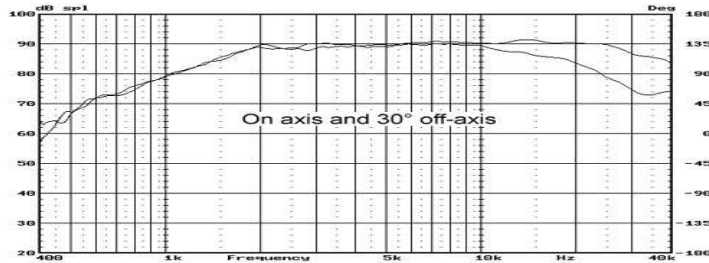

## TN25 Tweeter



- Fabric dome tweeter
- 54.5mm square flange
- Shielded, w/ chamber

Znom	5	ohm
fs	1500	Hz
Nom. Power	15	W
Re	4.6	ohm
VC Ø	25	mm
Sensitivity		
2.83V / 1m	90	dB
Weight	0.09	kg

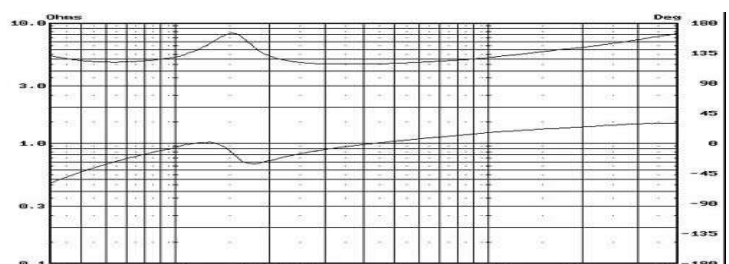
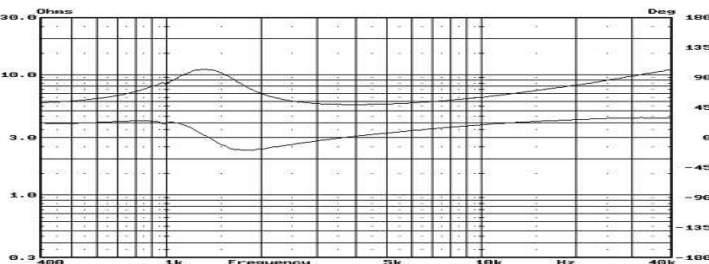
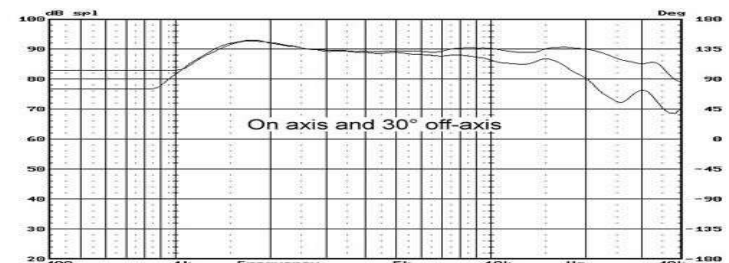



## K1 Tweeter



- Fabric dome tweeter
- 116mm round flange
- Shielded magnet

Znom	5	ohm
fs	800	Hz
Nom. Power	15	W
Re	4.6	ohm
VC Ø	25	mm
Sensitivity	2.83V / 1m	92 dB
Weight	0.9	kg

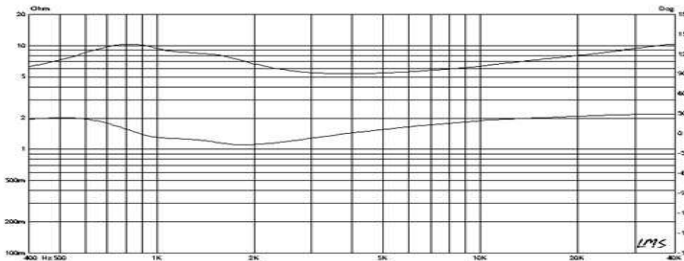
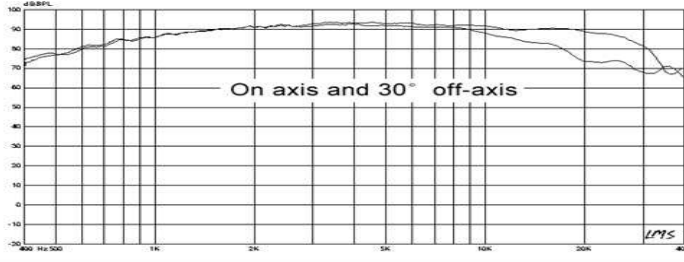

## X1R Tweeter



- Fabric dome tweeter
- 116mm flange
- Shielded magnet

Znom	4	ohm
fs	1600	Hz
Nom. Power	15	W
Re	3.5	ohm
VC Ø	25	mm
Sensitivity	2.83V / 1m	91 dB
Weight	0.62	kg

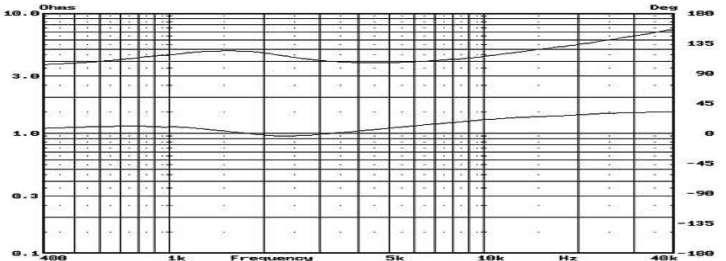
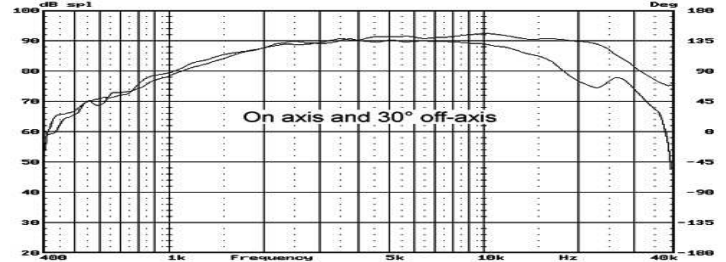

## DMN-A Midrange



- 2" fabric dome
- Chambered back
- Shielded magnet
- 116mm round flange

Znom	5	ohm
fs	800	Hz
Nom. Power	60	W
Re	4.3	ohm
VC Ø	50	mm
Sensitivity	2.83V / 1m	93 dB
Weight	0.4	kg

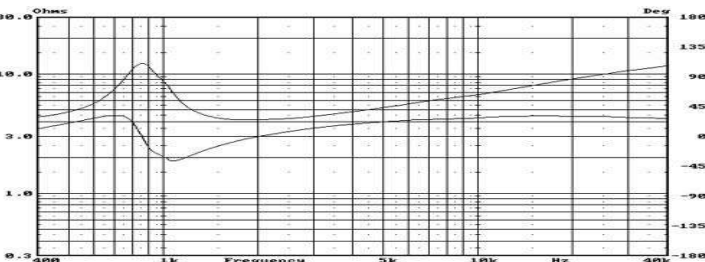
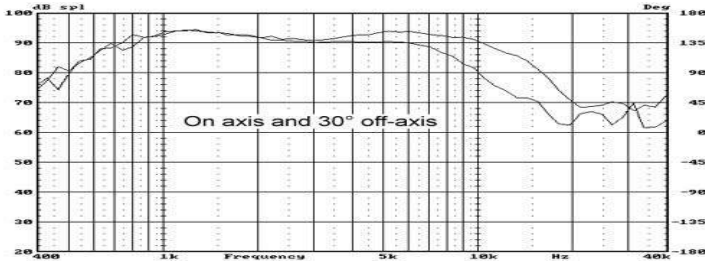

## DMB-A Midrange



- 2" textured fabric dome
- Shielded magnet
- 145mm round flange

Znom	5	ohm
fs	700	Hz
Nom. Power	80	W
Re	4.3	ohm
VC Ø	50	mm
Sensitivity	2.83V / 1m	92 dB
Weight	1.6	kg

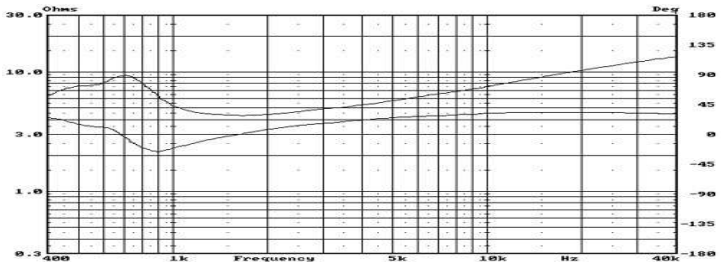
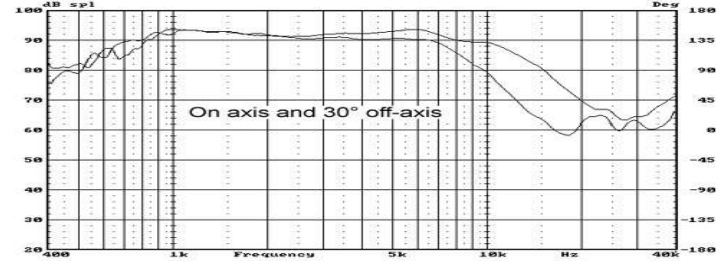



## TM1A Combo System

- Tweeter/Midrange combo
- Frequency range 800Hz to 20kHz
- Fabric domes
- TN28 & DMN drivers
- Suggested crossover point 3kHz to 4.5kHz



Znom	6/5 ohm
Nom. Power	15/60 Watts
Sensitivity	90/93 dB
2.83V / 1m	
Magnet System	Neodymium
Weight	0.75 kg

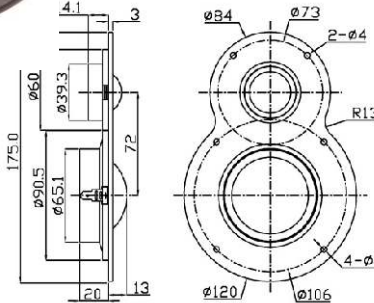

## A2S Full Range



Znom	8 ohm
fs	153 Hz
Nom. Power	10 W
Re	6.5 ohm
Qms	7.33
Qes	1.53
Qts	1.27
Mms	1.5 g
Cms	707 $\mu$ M/N

- 2" magnesium/aluminum cone full range (copper)
- Neodymium magnet
- Rubber surround
- Frequency range 150Hz-15kHz
- Shielded magnet
- 53mm square flange
- 48mm cut out
- 30.5mm depth

Sd	13 cm <sup>2</sup>
BL	2.5 Tm
Vas	0.2 ltrs
Xmax	1.5 mm peak
VC Ø	25 mm
Sensitivity	78 dB
2.83V / 1m	
Weight	0.12 kg
Rec.	0.5-5 liters sealed, f3 150

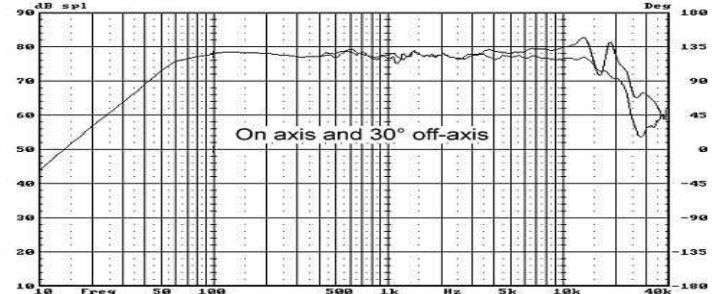
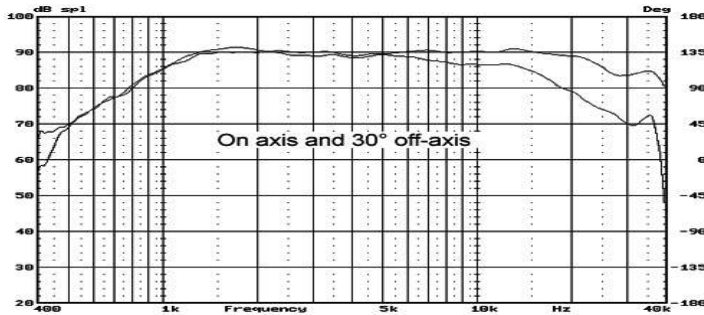

## B2S Full Range

- 2" magnesium/aluminum cone full range (copper)
- Neodymium magnet
- Rubber surround
- Frequency range 150Hz-15kHz
- Shielded magnet
- 53mm square flange
- 48mm cut out
- 30.5mm depth



Znom	8 ohm	Sd	13 cm <sup>2</sup>
fs	152 Hz	BL	2.5 Tm
Nom. Power	10 W	Vas	0.2 ltrs
Re	6.5 ohm	Xmax	1.5 mm peak
Qms	5.69	VC Ø	25 mm
Qes	1.53	Sensitivity	78 dB
Qts	1.20	2.83V / 1m	
Mms	1.6 g	Weight	0.12 kg
Cms	689 $\mu$ M/N	Rec.	0.5-5 liters sealed, f3 150

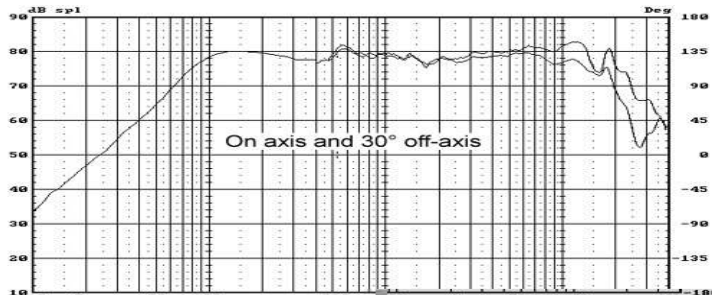

## U2S Full Range



Znom	8 ohm	Sd	13 cm <sup>2</sup>
fs	290 Hz	BL	3.0 Tm
Nom. Power	5 W	Vas	0.1 ltrs
Re	6.5 ohm	Xmax	1.8 mm peak
Qms	5.17	VC Ø	25 mm
Qes	1.43	Sensitivity	83 dB
Qts	1.12	2.83V / 1m	
Mms	1.2 g	Weight	0.1 kg
Cms	261 $\mu$ M/N	Rec.	Sealed/Open baffle? 245Hz?

- 2" coated aluminum alloy cone full range
- Neodymium magnet
- Transparent surround
- Frequency range 245Hz-20kHz
- Shielded magnet
- 53mm square flange
- 48mm cut out
- 30.5mm depth

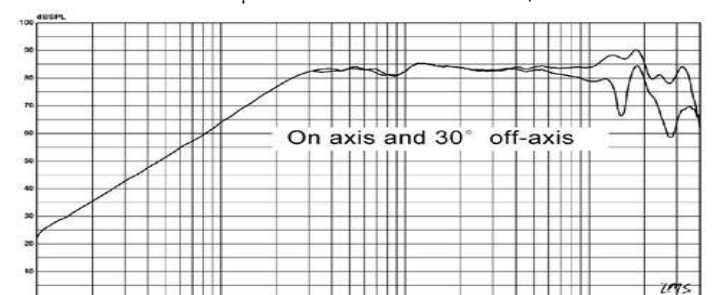

## M3S Full Range



- 3" magnesium/aluminum cone full range
- Copper color
- Shielded magnet
- Rubber surround
- Frequency range 90Hz-10kHz
- 78mm square flange
- 70mm cut out
- 53mm depth

Znom	8 ohm	Sd	30 cm <sup>2</sup>
fs	90 Hz	BL	3.1 Tm
Nom. Power	15 W	Vas	1.2 ltrs
Re	6.5 ohm	Xmax	3.0 mm peak
Qms	3.62	VC Ø	20 mm
Qes	1.17	Sensitivity	
Qts	0.88	2.83V / 1m	81 dB
Mms	3.2 g	Weight	0.53 kg
Cms	975 µM/N	Rec.box	1.5-5 liters sealed, f3 90

## B3S Full Range



- 3" magnesium/aluminum cone full range
- Copper color
- Shielded magnet
- Rubber surround
- Frequency range 80Hz-8kHz
- 78mm square flange
- 70mm cut out
- 53mm depth

Znom	8 ohm	Sd	30 cm <sup>2</sup>
fs	80 Hz	BL	2.9 Tm
Nom. Power	15 W	Vas	1.6 ltrs
Re	6.5 ohm	Xmax	3.0 mm peak
Qms	4.29	VC Ø	20 mm
Qes	1.19	Sensitivity	
Qts	0.93	2.83V / 1m	80 dB
Mms	3.1 g	Weight	0.53 kg
Cms	1260 µM/N	Rec.box	0.5-5 liters sealed, f3 80

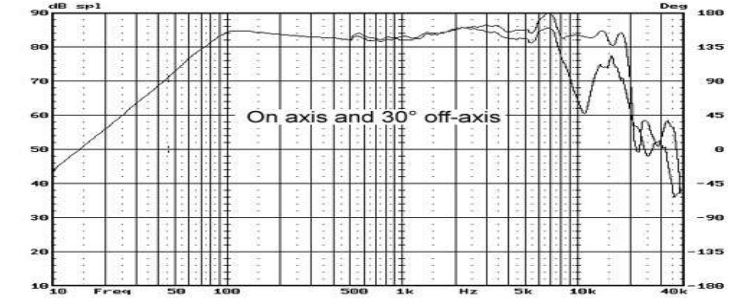
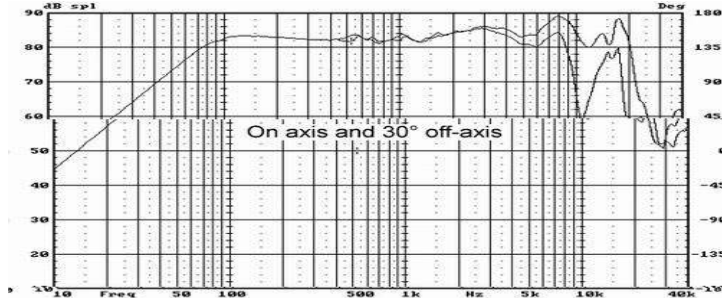

## B3N Full Range



- 3" magnesium/aluminum cone full range
- Copper color
- Shielded magnet
- Rubber surround
- Frequency range 80Hz-8kHz
- 90mm round flange
- 71mm cut out
- 53mm depth

Znom	8 ohm	Sd	30 cm <sup>2</sup>
fs	77 Hz	BL	3.1 Tm
Nom. Power	15 W	Vas	1.7 ltrs
Re	6.5 ohm	Xmax	3.0 mm peak
Qms	4.48	VC Ø	20 mm
Qes	1.07	Sensitivity	
Qts	0.86	2.83V / 1m	81 dB
Mms	3.2 g	Weight	0.55 kg
Cms	1320 µM/N	Rec.box	0.5-5 liters sealed, f3 80

## D6.8 Midbass



- 7" mineral filled polypropylene cone
- Cast frame
- Rubber surround
- 3" Voice coil
- Frequency range 40Hz-4kHz
- 174mm flange
- 136mm cut out
- 76mm depth

Znom	8 ohm	Sd	121 cm <sup>2</sup>
fs	42 Hz	BL	9.5 Tm
Nom. Power	60 W	Vas	13.5 ltrs
Re	6.5 ohm	Xmax	4.8 mm peak
Qms	3.81	VC Ø	76 mm
Qes	0.45	Sensitivity	
Qts	0.40	2.83V / 1m	85 dB
Mms	21.8 g	Weight	1.9 kg
Cms	652 µM/N	Rec. box	12 ltrs, 1.5"Ø x 5", F3 42

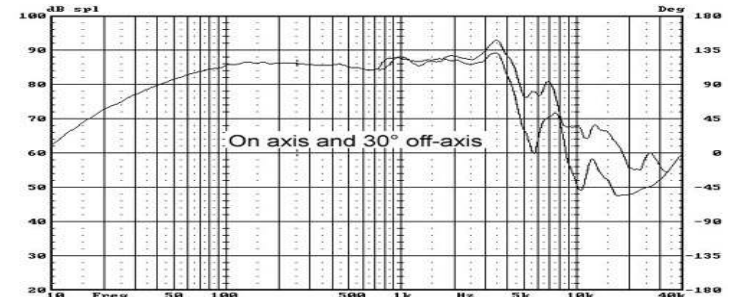
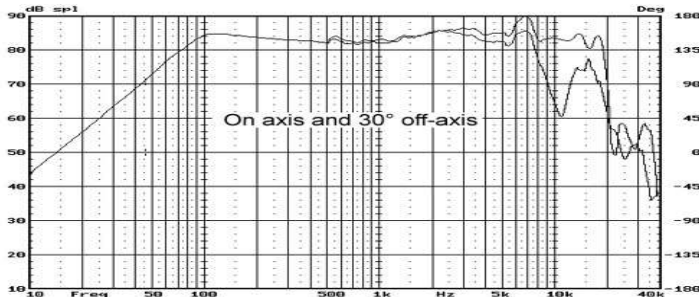



## D8.8 Woofer



- 9" mineral filled polypropylene cone
- Cast frame
- Foam surround
- 4" Voice Coil
- Frequency range 30Hz-2kHz
- 243mm flange
- 202mm cut out
- 96.5mm depth

Znom	8 ohm	Sd	241 cm <sup>2</sup>
fs	30 Hz	BL	11.7 Tm
Nom. Power	150 W	Vas	46.8 ltrs
Re	6.5 ohm	Xmax	8.3 mm peak
Qms	1.97	VC Ø	100 mm
Qes	0.46	Sensitivity	
Qts	0.38	2.83V / 1m	87 dB
Mms	50.9 g	Weight	3.5 kg
Cms	545 µM/N	Rec. Box:	31 ltrs, 2"Ø x 5.75" F3

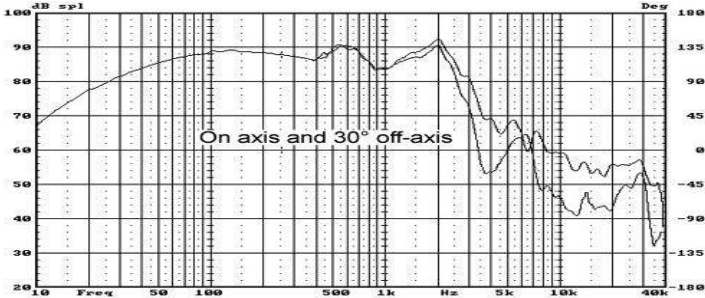

## D10.8 Woofer



- 11" mineral filled polypropylene cone
- Cast frame
- Foam surround
- 4" Voice Coil
- Frequency range 35Hz-500Hz
- 299 mm flange
- 255mm cut out
- 107mm depth

Znom	8 ohm	Sd	434 cm <sup>2</sup>
fs	20 Hz	BL	11.2 Tm
Nom. Power	150 W	Vas	211.2 ltrs
Re	6.5 ohm	Xmax	8.3 mm peak
Qms	2.11	VC Ø	100 mm
Qes	0.49	Sensitivity	
Qts	0.40	2.83V / 1m	87 dB
Mms	74.2 g	Weight	4.00 kg
Cms	864 µM/N	Rec. Box:	90 liters sealed, F3 35

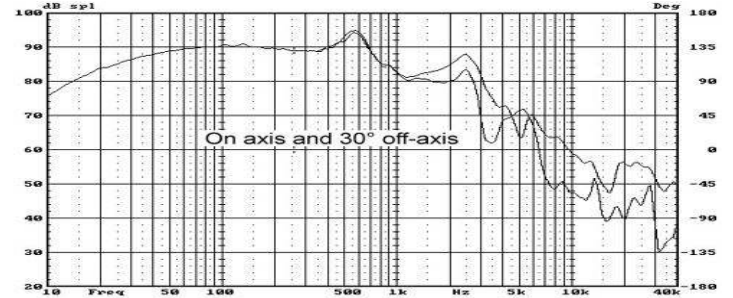

## F5 Midbass



- 5.5" Kevlar®/Paper cone
- Phase plug
- Cast frame
- Rubber surround
- Shielded magnet
- Frequency range 65Hz-8kHz
- 154mm flange
- 116.5mm cut out
- 89mm depth

Znom	8 ohm	Sd	79 cm <sup>2</sup>
fs	52 Hz	BL	8.3 Tm
Nom. Power	35 W	Vas	7.3 ltrs
Re	6.5 ohm	Xmax	2.7 mm peak
Qms	4.31	VC Ø	25 mm
Qes	0.36	Sensitivity	
Qts	0.33	2.83V / 1m	86 dB
Mms	11.5 g	Weight	1.6 kg
Cms	828 µM/N	Rec. Box:	4 ltrs, 1"Ø x 4" F3 63

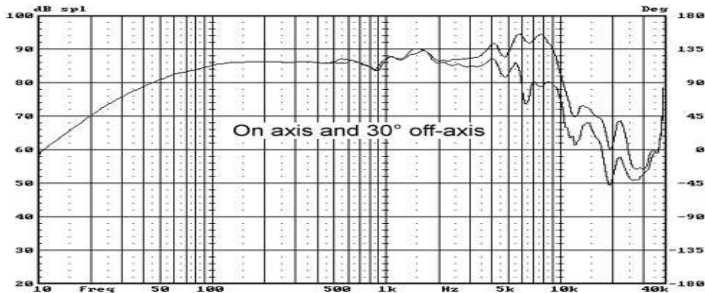

## F6 Midbass



- 7" Kevlar®/Paper cone
- Phase plug
- Cast frame
- Rubber surround
- Shielded magnet
- Frequency response 50Hz-5kHz
- 197mm flange
- 149mm cut out
- 92mm depth

Znom	8 ohm	Sd	139 cm <sup>2</sup>
fs	45 Hz	BL	9.0 Tm
Nom. Power	45 W	Vas	16.4 ltrs
Re	6.5 ohm	Xmax	4.3 mm peak
Qms	3.91	VC Ø	25 mm
Qes	0.38	Sensitivity	
Qts	0.35	2.83V / 1m	88 dB
Mms	18.3 g	Weight	2.1 kg
Cms	658 µM/N	Rec. Box:	11 ltrs, 1.5"Ø x 3.75" F3

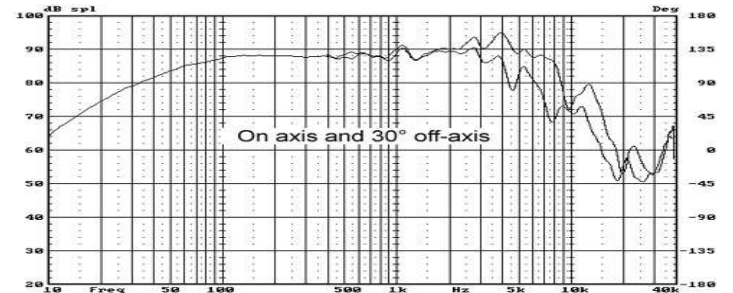



## F8 Woofer



- 8" Kevlar®/Paper cone
- Cast frame
- Rubber surround
- Shielded magnet
- Frequency response 38Hz-3kHz
- 239mm flange
- 187mm cut out
- 106mm depth

Znom	8 ohm	Sd	214 cm <sup>2</sup>
fs	36 Hz	BL	10.1 Tm
Nom. Power	60 W	Vas	36.9 ltrs
Re	6.5 ohm	Xmax	5.0 mm peak
Qms	1.73	VC Ø	35 mm
Qes	0.51	Sensitivity	
Qts	0.39	2.83V / 1m	87 dB
Mms	35.3 g	Weight	2.9 kg
Cms	567 µM/N	Rec. Box: 30 ltrs, 2"Ø x 4.3" F3 38	

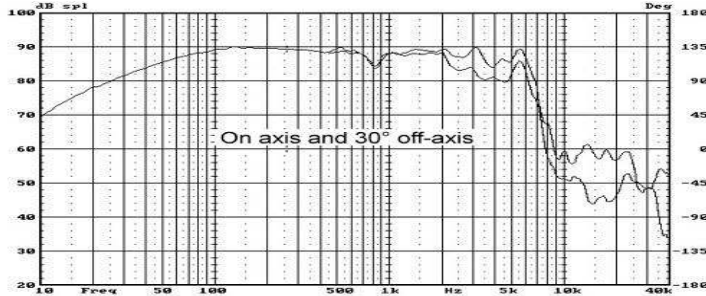

## M5N Midbass



- 5" Magnesium/ Aluminum alloy cone
- Stamped steel frame
- Rubber surround
- Shielded magnet
- Frequency response 53Hz-5kHz
- 144mm flange
- 115mm cut out
- 91mm depth

Znom	8 ohm	Sd	87 cm <sup>2</sup>
fs	47 Hz	BL	7.5 Tm
Nom. Power	35 W	Vas	11.3 ltrs
Re	6.5 ohm	Xmax	2.7 mm peak
Qms	6.51	VC Ø	25 mm
Qes	0.37	Sensitivity	
Qts	0.35	2.83V / 1m	87 dB
Mms	10.7 g	Weight	1.5 kg
Cms	1051 µM/N	Rec. Box: 6 ltrs, 1"Ø x 2.3" F3 59	

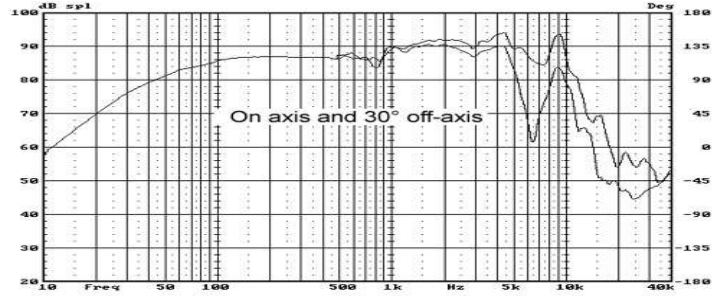

## M5a Midbass



- 5" Magnesium/ Aluminum alloy cone
- Cast frame
- Rubber surround
- Shielded magnet
- Frequency response 54Hz-8kHz
- 140mm flange
- 116mm cut out
- 89.2mm depth

Znom	8 ohm	Sd	87 cm <sup>2</sup>
fs	48 Hz	BL	7.6 Tm
Nom. Power	35 W	Vas	11.2 ltrs
Re	6.5 ohm	Xmax	2.7 mm peak
Qms	6.71	VC Ø	25 mm
Qes	0.36	Sensitivity	
Qts	0.34	2.83V / 1m	87 dB
Mms	10.8 g	Weight	1.6 kg
Cms	1038 µM/N	Rec. Box: 5 ltrs, 1"Ø x 2.6" F3 63	

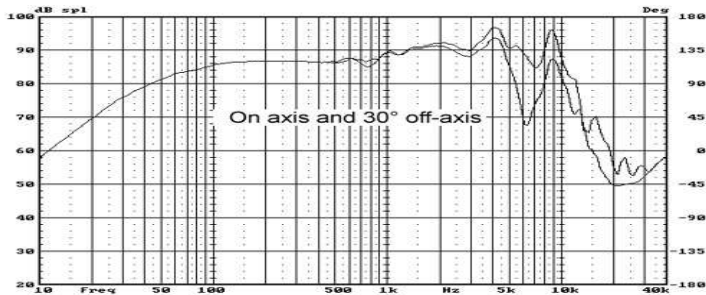

## M6a Midbass



- 7" Magnesium / Aluminum alloy cone
- Cast frame
- Rubber surround
- Shielded magnet
- Frequency response 50Hz-5kHz
- 174mm flange
- 148mm cut out
- 95mm depth

Znom	8 ohm	Sd	139 cm <sup>2</sup>
fs	46 Hz	BL	7.8 Tm
Nom. Power	45 W	Vas	21.9 ltrs
Re	6.5 ohm	Xmax	4.3 mm peak
Qms	3.94	VC Ø	25 mm
Qes	0.42	Sensitivity	
Qts	0.38	2.83V / 1m	88 dB
Mms	13.6 g	Weight	2.0 kg
Cms	874 µM/N	Rec. Box: 14 ltrs, 2"Ø x 5" F3 53	

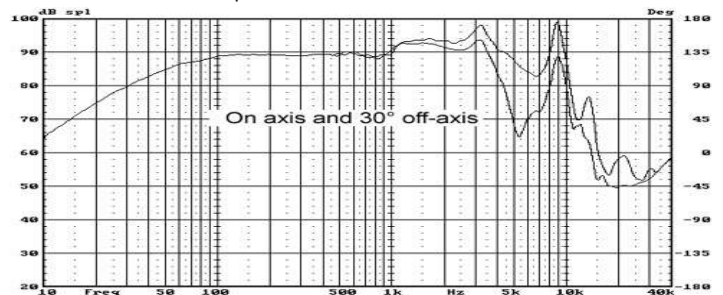

## M8a Woofer



- 8" Magnesium / Aluminum alloy cone
- Cast frame
- Rubber surround
- Copper color cone
- Frequency response 30Hz-2kHz
- 215mm flange
- 187mm cut out
- 99mm depth

Znom	8 ohm	Sd	214 cm <sup>2</sup>
fs	30 Hz	BL	9.6 Tm
Nom. Power	80 W	Vas	50.3 ltrs
Re	6.5 ohm	Xmax	5.8 mm peak
Qms	4.90	VC Ø	35 mm
Qes	0.47	Sensitivity	
Qts	0.43	2.83V / 1m	87 dB
Mms	35.1 g	Weight	2.5 kg
Cms	773 µM/N	Rec. Box: 40 ltrs, 2" x 5.1" F3 32	

## M12 Woofer



- 12" Magnesium / Aluminum alloy cone
- Cast frame
- Rubber surround
- 4 ohm
- Frequency response 30Hz-1.5kHz
- 336mm flange
- 280mm cut out
- 143mm depth

Znom	4 ohm	Sd	531 cm <sup>2</sup>
fs	27 Hz	BL	16.8 Tm
Nom. Power	150 W	Vas	81.4 ltrs
Re	3.4 ohm	Xmax	7.2 mm peak
Qms	4.87	VC Ø	50 mm
Qes	0.36	Sensitivity	
Qts	0.33	2.83V / 1m	93 dB
Mms	161.5 g	Weight	8.0 kg
Cms	203.2 µM/N	Rec Box: 53 liters, 3"Ø x 7.5", F3	

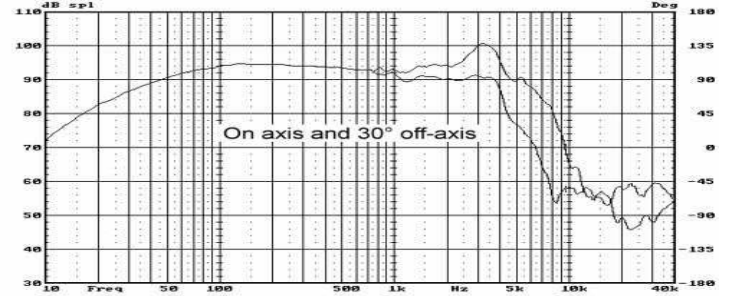
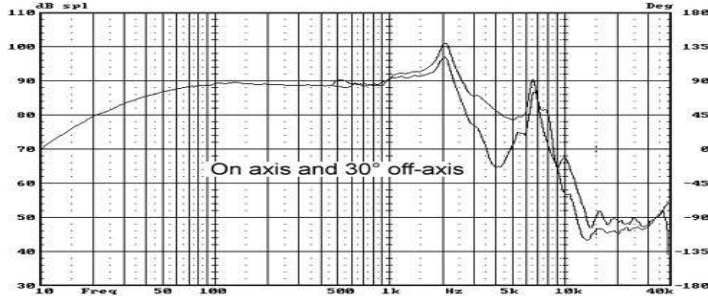

## W5 Midbass



- 5" Super-PPF polymer film cone
- Cast frame, Shielded
- Rubber surround
- Phase plug
- Frequency response 50Hz-7kHz
- 153mm flange
- 115mm cut out
- 94mm depth

Znom	8 ohm	Sd	87 cm <sup>2</sup>
fs	57 Hz	BL	6.2 Tm
Nom. Power	35 W	Vas	8.6 ltrs
Re	6.5 ohm	Xmax	2.5 mm peak
Qms	3.17	VC Ø	25 mm
Qes	0.58	Sensitivity	
Qts	0.49	2.83V / 1m	86 dB
Mms	9.8 g	Weight	1.8 kg
Cms	802 µM/N	Rec. Box: 9 ltrs, 1.5"Ø x 3.25" F3	

## W6 Midbass



- 7" Super-PPF polymer film cone
- Cast frame
- Shielded magnet
- Frequency response 55Hz-3kHz
- 179mm frame
- 149mm cut out
- 94mm depth

Znom	8 ohm	Sd	139 cm <sup>2</sup>
fs	40 Hz	BL	6.7 Tm
Nom. Power	45 W	Vas	25.1 ltrs
Re	6.5 ohm	Xmax	4.3 mm peak
Qms	3.04	VC Ø	25 mm
Qes	0.64	Sensitivity	
Qts	0.52	2.83V / 1m	90 dB
Mms	17.1 g	Weight	2.5 kg
Cms	913 µM/N	Rec. Box: 15 ltrs sealed, F3 55	

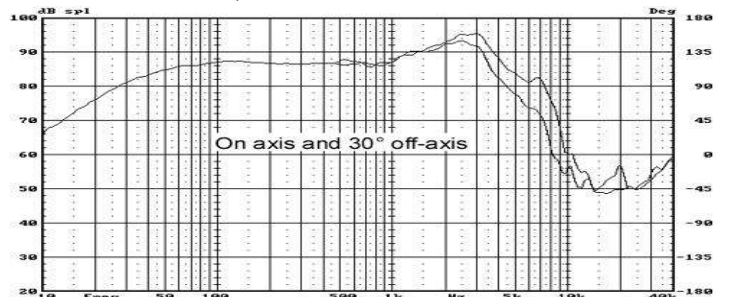
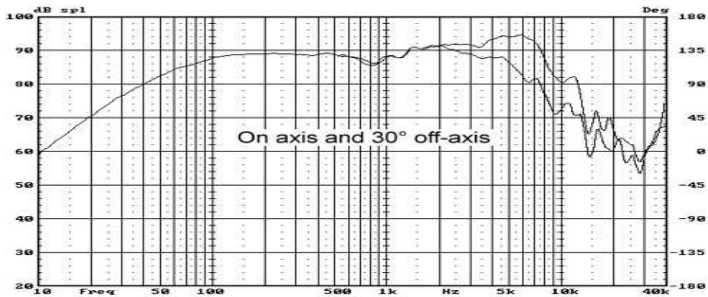





# 25NFA, 26NA & 26NAFM

## 1" neodymium magnet tweeters

Compact high efficiency dome tweeters with smooth and extended frequency response. Variable mounting to fit your applications. Ferrofluid cooled for higher power handling.

Technical Data	Symbol	Value	Unit
Nominal Impedance	$Z_n$	8	$\Omega$
DC Resistance	$R_{dc}$	6.8	$\Omega$
Resonant Frequency	$f_r$	1850	Hz
Rated Power		80	W
SPL 1W/1m		92	db
Total Moving Mass	$M_{MS}$	0.22	g
Effective Piston Area	$S_D$	6.8	cm <sup>2</sup>
Voice Coil Diameter		25	mm
Voice Coil Former		Nomex	
Voice Coil Length		1.5	mm
Voice Coil Layers		2	
Flux Density	B	1.35	Tesla
Force Factor	$B_L$	2.4	Tm
Gap Height		2	mm
Magnet Diameter		32	mm
Magnet Height		8	mm
Magnet Weight		0.05	kg
Mass of Speaker		0.07	kg

**25NFA \$43.00 each**

**26NA \$37.00 each**

**25NAFM \$37.00 each**

### 25NFA & 26NA

Flange diameter 48 mm  
Cutout hole  $\varnothing$  46 mm  
Depth 10 mm

### 26NAFM

Flange diameter 67 mm  
Cutout hole  $\varnothing$  48 mm  
Depth 10 mm



26NA Aluminum dome



25NFA Textile dome



Hinged Wedge Mount



Wedge Mount



Flush Mount

- Wedge mounting; \$2.00 each (LPGWM)
- Hinged Wedge mounting; \$3.50 each (HWM)
- Flush mounting; \$3.50 each (LPGFM)

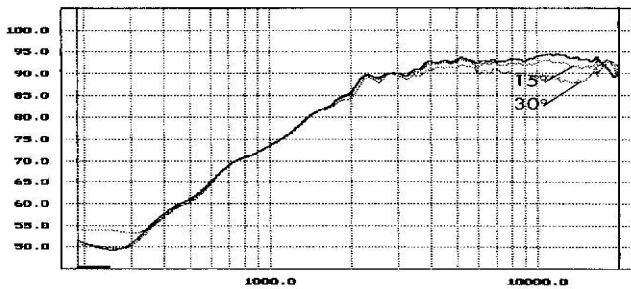

26NAFM Flush Mount Tweeter



# 50FA

## 2" dome midrange

Price \$61.00

50 mm textile soft dome midrange with extremely smooth response and wide dispersion.

- specially doped textile soft dome
- black aluminum front plate



Technical Data	Symbol	Value	Unit
Nominal Impedance	$Z_n$	8	$\Omega$
DC Resistance	$R_{dc}$	5.7	$\Omega$
Resonant Frequency	$f_r$	390	Hz
Rated Power		100	W
SPL 1W/1m		90	db
Total Moving Mass	$M_{MS}$	1.76	g
Effective Piston Area	$S_D$	26	cm <sup>2</sup>
Voice Coil Diameter		50	mm
Voice Coil Former		Aluminum	
Voice Coil Length		4.3	mm
Voice Coil Layers		1	
Flux Density	B	1.3	Tesla
Force Factor	$B_L$	3.7	Tm
Gap Height		3	mm
Magnet Diameter		102	mm
Magnet Height		17	mm
Magnet Weight		0.47	kg
Mass of Speaker		1.2	kg
Flange diameter		140	mm
Cutout hole diameter		105	mm
Depth		27	mm



# 25RFK

## 1" dome tweeter

Price \$16.00

25 mm textile dome tweeter with very smooth response, even above 20KHz.

- textile dome
- black polyimid front plate
- ferrofluid cooled
- replaceable voice coil



Technical Data	Symbol	Value	Unit
Nominal Impedance	$Z_n$	8	$\Omega$
DC Resistance	$R_{dc}$	6.4	$\Omega$
Resonant Frequency	$f_r$	1200	Hz
Rated Power		90	W
SPL 1W/1m		89	db
Total Moving Mass	$M_{MS}$	0.22	g
Effective Piston Area	$S_D$	6.8	cm <sup>2</sup>
Voice Coil Diameter		25	mm
Voice Coil Former		Aluminum	
Voice Coil Length		1.5	mm
Voice Coil Layers		2	
Flux Density	B	1.2	Tesla
Force Factor	$B_L$	2.15	Tm
Gap Height		2.5	mm
Magnet Diameter		60	mm
Magnet Height		10	mm
Magnet Weight		0.1	kg
Mass of Speaker		0.27	kg
Flange diameter		96	mm
Cutout hole diameter		70	mm
Depth		17	mm

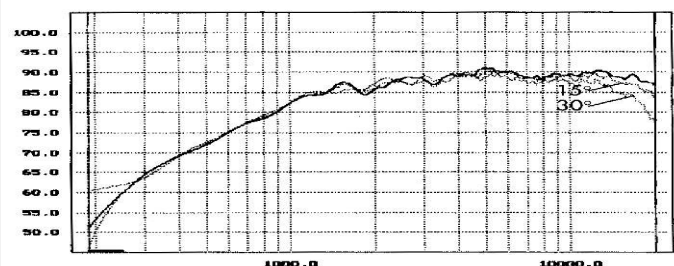
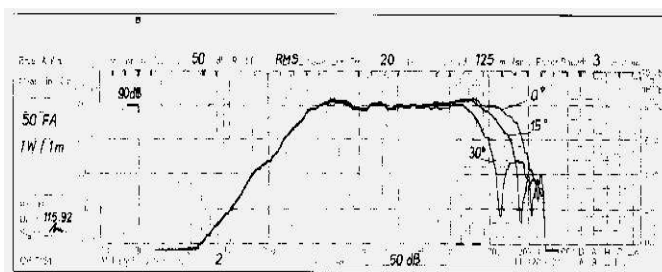





## 25FA

1" dome tweeter  
Price \$35.00

25 mm soft dome tweeter with extraordinarily wide frequency response and excellent sound quality

- pre-coated textile dome
- black aluminum front plate
- magnetic fluid
- grill frame available



Technical Data	Symbol	Value	Unit
Nominal Impedance	$Z_n$	8	$\Omega$
DC Resistance	$R_{dc}$	6.8	$\Omega$
Resonant Frequency	$f_r$	1100	Hz
Rated Power		100	W
SPL 1W/1m		90	db
Total Moving Mass	$M_{MS}$	0.22	g
Effective Piston Area	$S_D$	6.8	cm <sup>2</sup>
Voice Coil Diameter		25	mm
Voice Coil Former	Aluminum		
Voice Coil Length		1.5	mm
Voice Coil Layers		2	
Flux Density	B	1.6	Tesla
Force Factor	$B_L$	3.0	Tm
Gap Height		3	mm
Magnet Diameter		72	mm
Magnet Height		15	mm
Magnet Weight		0.25	kg
Mass of Speaker		0.5	kg
Flange diameter		110	mm
Cutout hole diameter		74	mm
Depth		23	mm

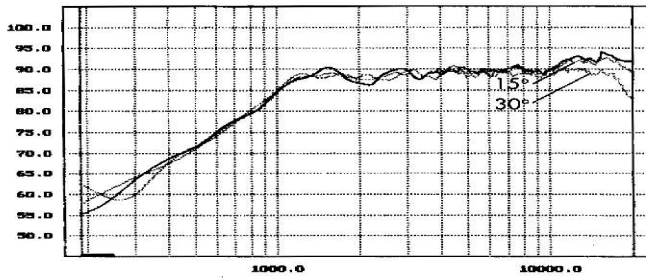

## 25FS

1" dome tweeter  
Price \$xx.xx

25 mm fabric dome tweeter with shielded magnet for use near CRT

- fabric dome
- cast aluminum face plate
- shielded magnet

Discontinued



Technical Data	Symbol	Value	Unit
Nominal Impedance	$Z_n$	8	$\Omega$
DC Resistance	$R_{dc}$	6.4	$\Omega$
Resonant Frequency	$f_r$	800	Hz
Rated Power		100	W
SPL 1W/1m		88	db
Total Moving Mass	$M_{MS}$	0.24	g
Effective Piston Area	$S_D$	6.8	cm <sup>2</sup>
Voice Coil Diameter		25	mm
Voice Coil Former	Aluminum		
Voice Coil Length		1.4	mm
Voice Coil Layers		2	
VC Inductance	$L_c$	0.1	mH
Flux Density	B	1.6	Tesla
Force Factor	$B_L$	2.2	Tm
Gap Height		2.5	mm
Magnet Diameter		68/60	mm
Magnet Height		13/10	mm
Mass of Speaker		0.64	kg
Flange diameter		105	mm
Cutout hole diameter		81	mm
Depth		33	mm

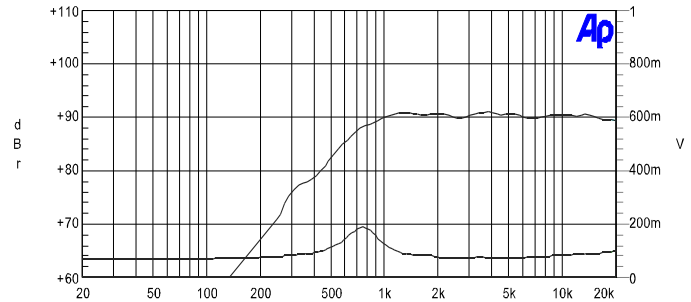

## 26T

1" dome tweeter  
Price \$45.00

25 mm titanium dome tweeter with high efficiency and wide frequency response

- titanium dome
- black aluminum front plate
- double magnet
- vented pole piece
- grill frame



Technical Data	Symbol	Value	Unit
Nominal Impedance	$Z_n$	8	$\Omega$
DC Resistance	$R_{dc}$	6.8	$\Omega$
Resonant Frequency	$f_r$	730	Hz
Rated Power		100	W
SPL 1W/1m		90	db
Total Moving Mass	$M_{MS}$	0.28	g
Effective Piston Area	$S_D$	6.8	cm <sup>2</sup>
Voice Coil Diameter		25	mm
Voice Coil Former	Aluminum		
Voice Coil Length		1.5	mm
Voice Coil Layers		2	
Flux Density	B	1.8	Tesla
Force Factor	$B_L$	3.2	Tm
Gap Height		1.5	mm
Magnet Diameter		72	mm
Magnet Height		2 x 15	mm
Magnet Weight		2 x .25	kg
Mass of Speaker		0.75	kg
Flange diameter		110	mm
Cutout hole diameter		74	mm
Depth		41	mm

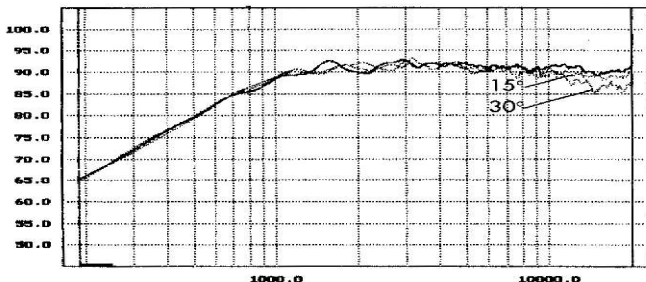

## 51AT

2" midrange dome  
Price \$72.00

50 mm metal midrange dome with high efficiency and extraordinarily wide frequency response

- aluminum dome
- rubber surround
- black aluminum front plate
- rear chamber
- vented pole piece
- grill frame

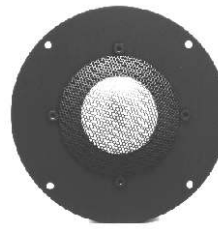

Technical Data	Symbol	Value	Unit
Nominal Impedance	$Z_n$	8	$\Omega$
DC Resistance	$R_{dc}$	5.7	$\Omega$
Resonant Frequency	$f_r$	480	Hz
Rated Power		100	W
SPL 1W/1m		93	db
Total Moving Mass	$M_{MS}$	1.27	g
Effective Piston Area	$S_D$	26	cm <sup>2</sup>
Voice Coil Diameter		50	mm
Voice Coil Former	Aluminum		
Voice Coil Length		4.3	mm
Voice Coil Layers		1	
Flux Density	B	1.3	Tesla
Force Factor	$B_L$	3.7	Tm
Gap Height		3	mm
Magnet Diameter		102	mm
Magnet Height		17	mm
Magnet Weight		0.47	kg
Mass of Speaker		1.2	kg
Flange diameter		140	mm
Cutout hole diameter		105	mm
Depth		46	mm

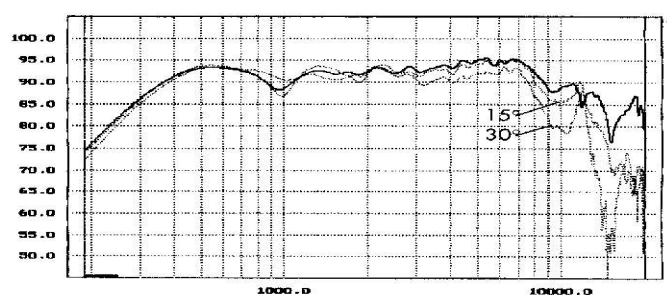

# Madisound Presents Sledgling

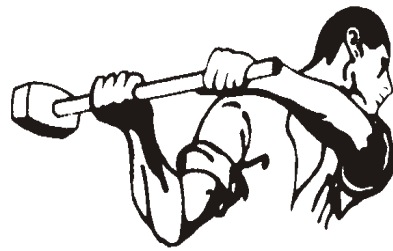

The Sledgling is the best little bookshelf speaker kit on the market today. This kit gives you the quality sound of commercially produced speaker at a fraction of the price. The Sledgling speaker is small enough to fit unobtrusively in any den or be used as a rear channel speaker in a four channel audio or video system. We chose a high quality six and one half inch polypropylene woofer and a Vifa treated textile dome tweeter with ferrofluid for a very clean sound. We have utilized the best possible components in the crossover network with Sidewinder coils and Chateauroux Metallized Polypropylene capacitors on an epoxy circuit board.

The kit is designed to be as easy as possible to assemble. The cabinet is already finished. The holes for the drivers and the input cup are pre-cut; the crossover is preassembled, and the grill cloth is stretched on the frame.

## Specifications

Impedance	4 $\Omega$ or 8 $\Omega$
Sensitivity	89 DB
Power Rating	50 Watts
Freq. Range	65 - 18000 HZ +/- 2db
Woofer	6 1/2 "
Tweeter	3/4" Dome
Crossover	6/6 db w/ Sidewinder Coils and Polypropylene Capacitors
Cabinet	Oak Wood Veneer with 3/4" walls 8" W x 12" T x 7" D
Price	\$216.00 /pair Specify Clear or Black painted oak or Cherry \$106.00 /pair without cabinets

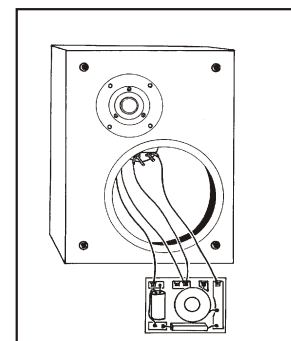
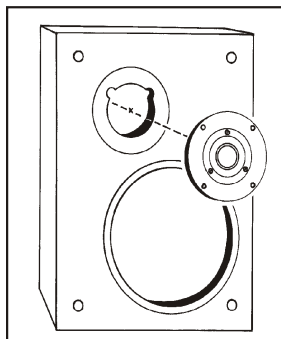
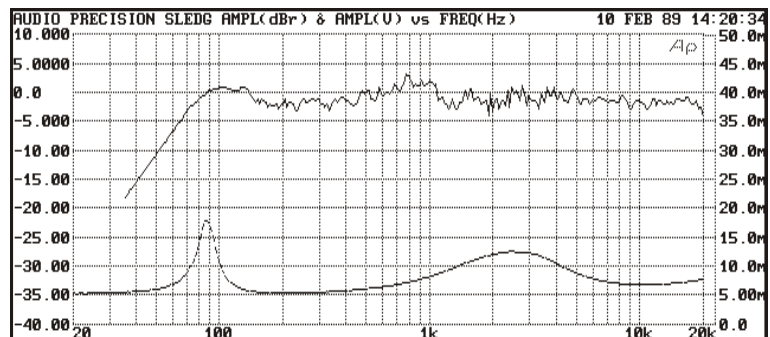

**Madisound 6102**  
**6.5" Polypropylene**  
**Woofer 4 or 8 Ω**

	6102-4	6102-8
Fs (Hz)	28.6	30.8
Rsc (Ω)	3.4	6.3
VcL(mH@1K)	.403	.552
Qms	7.28	7.40
Qes	.27	.37
Qts	.26	.35
Mmd (g)	7.87	9.61
Cms (μm/N)	3590.6	2570.1
Vas (Ltrs)	77.1	55.2
Efficiency (dB 2.83V/1m)	92	89
Xmax	3.5mm pk	
Power	50 w	
Magnet	12 oz.	
Cone	Black Poly	
Surround	Foam	
Voice Coil	1" 2-Layer Kapton	
Cutout/Depth	5 9/16" / 2.87"	
Frame	6 9/16"	
<b>Price</b>	<b>\$25.00</b>	



Vented pole piece

	Vented		Sealed	
	4 Ω	8 Ω	4 Ω	8 Ω
VB ltrs	18	40	11.4	28
FB Hz	36	30	~	~
F3 Hz	41	33	58	47
Port Diameter	1.5"	2"	Qtc= .7	Qtc= .7
Length	4.6"	5.2"	Rg=.4	Rg=.4

AUDIO PRECISION : 6102-04 & 6102-08

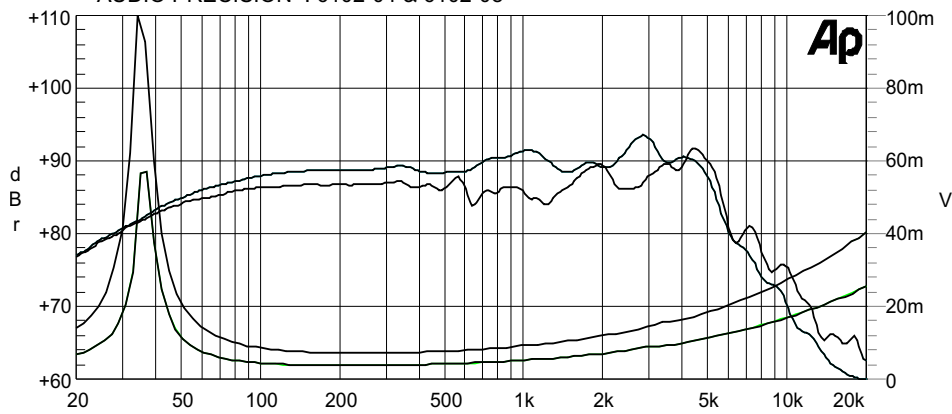





**5% off on 4 or more pieces of the same item.**



### Morel Tweeters

Model	Imp. Ω	Fs Hz	Nom. Power	dB 2.83V/m	Price Each
<b>SUPREME 110</b> High Performance 28mm dome tweeter	8	680	220	91.5	\$334.00pr
<b>SUPREME 130</b> High Performance 28mm dome tweeter	8	680	220	91.5	\$445.00pr
<b>MDT10</b> 28mm dome tweeter, Solin Range	8	1000	80	90	\$31.00
<b>MDT12</b> 28mm dome tweeter w/ Neodymium magnet, 2.13" sq, 0.6" deep	8	1000	80	89	\$31.00
<b>MDT20</b> 28mm dome tweeter	8	650	120	90	\$33.00
<b>DMS20</b> Shielded version of MDT20	8	650	120	90	\$37.00
<b>MDT22</b> 28mm dome tweeter w/ chamber and neodymium magnet	8	650	80	89	\$33.00
<b>MDT29</b> 28mm dome tweeter	8	900	80	89	\$47.00
<b>MDT30S</b> 28mm dome tweeter	8	700	200	90	\$68.00
<b>DMS30-S</b> Shielded version of MDT30S	8	700	200	90	\$77.00
<b>MDT32S</b> 28mm dome tweeter with 110mm flange	8	700	200	90	\$73.00
<b>DMS32S</b> Shielded version of MDT32S	8	700	200	90	\$82.00
<b>MDT33</b> 28mm dome tweeter, triple magnet, matched pairs	8	700	200	92.5	\$148.00
<b>MDT37</b> 28mm horn loaded dome tweeter	8	700	200	93	\$65.00
<b>MDT38</b> 28mm dome tweeter, Top-mount	8	750	80	89	\$52.00
<b>MDT39</b> 28mm dome tweeter, chambered	8	750	80	88	\$52.00
<b>MDT40</b> 28mm dome tweeter, Neodymium magnet	8	750	120	89	\$72.00
<b>MDT41</b> 28mm dome tweeter, Neodymium magnet, Top mount tweeter	8	750	120	90	\$72.00
<b>MDT43</b> 28mm dome tweeter, Top mount, Double Neodymium magnet	8	750	120	92	\$97.00
<b>MDT44</b> 28mm dome tweeter, Double Neodymium magnet	8	750	120	91	\$97.00
<b>R-29 &amp; R-39</b> Voice Coil for MDT29 & Voice Coil for MDT39					\$13.00
<b>R-30</b> Voice Coil for MDT30S; <b>R-40</b> Voice Coil for MDT40					\$18.00
<b>R-32/33</b> Voice Coil for MDT32S & MDT33 & Supreme; <b>R-37</b> Voice Coil for MDT37; <b>R-44</b> Voice Coil for MDT44					\$20.00

### Midranges

Model	Imp. Ω	Fs Hz	Qts	Vas liters	Nom. Power	Efficiency 2.83V/1m	Box Liters Sealed/Vented	F3 Hz	Price Each
<b>MDM55</b> 55mm dome mid, Neodymium	8	380	-	-	200	90.5			\$86.00

### Classic Woofers

<b>MW113</b> 4" Poly cone woofer	8	72	.75	4.3	150	87	10S	70	\$84.00
<b>MW114-S</b> 4" Poly cone, Neo. magnet	4 or 8	80	.56	1.8	150	87	3S	100	\$127.00
<b>MW142</b> 5" Poly cone woofer	4 or 8	45	.40	11.7	150	86	7V / 5S	52 / 80	\$94.00
<b>MW144</b> 5" Poly cone woofer	4 or 8	52	.55	8	150	88	8S	67	\$94.00
<b>MW164</b> 6" Doped Paper cone woofer	4 or 8	48	.55	14.3	150	86	20 S	62	\$107.00
<b>MW166</b> 6" Poly cone woofer	4 or 8	48	.58	15.6	150	86	14 to 28 S	57 to 55	\$107.00
<b>MW168</b> 6" Poly cone woofer, low Q	4 or 8	44	.41	16	150	88	14V / 8S	44 / 77	\$107.00
<b>MW265</b> 8" Poly cone woofer, low Q	4 or 8	30	.61	61	150	89	60 to 90S	36 to 35	\$116.00
<b>MW266</b> 8" Doped Paper cone woofer	4 or 8	29	.56	80	150	89	56-100S	38-36	\$116.00
<b>MW1075</b> 10" Poly cone woofer	8	29	.62	123	180	89	90S	35	\$144.00

### Neolin Woofers - Neodymium Magnet System

<b>MW143</b> 5" Poly cone woofer	8	52	.36	9.5	150	89	5V / 3.5S	63 / 100	\$164.00
<b>MW167</b> 6" Poly cone woofer	8	44	.35	18.8	150	88	10V/S	55 / 88	\$176.00
<b>MW267</b> 8" Pole cone woofer	8	25	.33	113	180	89	52V/33S	34 / 53	\$185.00
<b>MW1077</b> 10" Poly cone woofer	8	28	.51	147	200	89	90S	40	\$212.00

### HU Cast Frame Uniflow Woofers - Neodymium & Ferrite Hybrid Magnet System

<b>HU521</b> 5" Poly cone bass/midrange	8	46	.37	9.9	160	88	7V/4S	51 / 85	\$124.00
<b>HU531</b> 5" Paper cone bass/midrange	8	46	.37	9.9	180	86	6V/4S	55 / 88	\$127.00
<b>HU621</b> 6" Poly cone woofer	8	43	.38	27	160	90	18V/11S	50 / 80	\$143.00
<b>HU631</b> 6" Poly cone woofer	8	44	.36	16.9	180	88	10V/6S	53 / 86	\$145.00
<b>HU9.1</b> 8" Poly cone woofer	8	30	.36	71	200	89	43V / 25S	36 / 59	\$157.00

## Supreme 110



## Supreme 130



SPECIFICATIONS: Supreme 110 & Supreme 130		
Overall Dimensions		110 (110mm), 130 (130mm)
Nominal Power Handling	P	220W 12dB @2200Hz 120W 6dB @2200Hz
Transient Power - 10ms		1000W
Nominal Impedance	Z	8 Ω
Sensitivity (2.83V@1M)		92.5dB
Frequency Response		1600 - 22,000Hz
Resonant Frequency	Fs	680Hz
Voice Coil Diameter	Ø	28mm (1.1")
Voice Coil Height		2.7mm (0.106")
Voice Coil Former		Aluminum
Voice Coil Wire		Hexatech Aluminum
Number Layers		2
DC Resistance	Re	5.2 Ω
Voice Coil Inductance	LBM	0.09mH @ 1KHz
Magnet System Type		Neodymium flat pancake
Magnetic Gap Height	He	4.2mm (0.16")
Dome Material		Acuflex™ Coated Textile
Net Weight	Kg	0.52 Kg.

Innovative engineering and an advanced approach to acoustic construction makes **SUPREME** a superior high performance tweeter. With an acoustic construction based on the *underhung voice coil* configuration method, **SUPREME**'s voice coil moves in a significantly higher magnetic field and *fully remains* there at all times during operation. As a result, **SUPREME** provides a *linear excursion of the coil in the magnetic field*; *eliminates intermodulation distortion created by non-linear excursion*; *eliminates sound compression at high levels*; and *considerably improves low frequency reproduction*

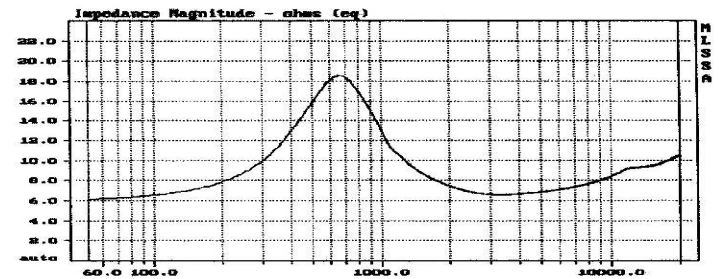
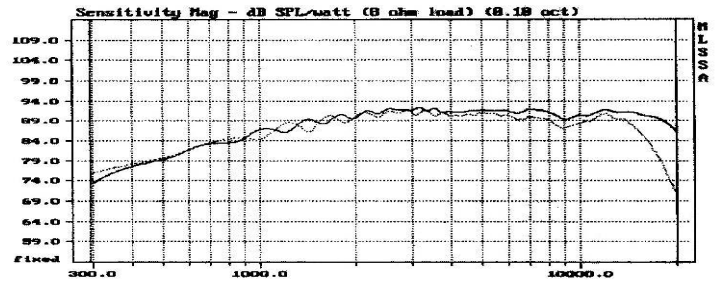

## MDT10 Tweeter



- 1" textile dome tweeter
- Ferrofluid cooled
- Replaceable voice coil
- Injected polymer face-plate
- Gold-plated terminals
- Flange 104mm (4.09")
- Cut-out 73mm (2.87")
- Depth 25mm (0.98")

Znom	8 ohm	Sd	6.0 cm <sup>2</sup>
Re	5.2 ohm	BL	3.5 N/A
Le@1kHz	0.05 mH	Vas	- ltrs
fs	1000 Hz	Xmax	- mm peak
Qms	-	VC Ø	28 mm
Qes	-	Sensitivity	
Qts	-	1W / 1m	90 dB
Mms	0.47 g	Nom. Power DIN	80 W
Cms	- mm/N	Net weight	0.65 kg

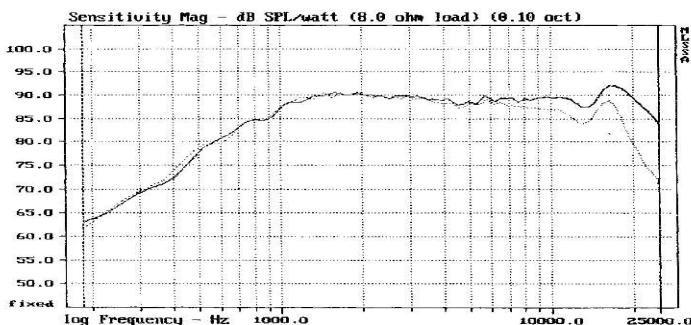

## MDT12 Tweeter



- 1" textile dome tweeter
- Ferrofluid cooled
- Neodymium magnet
- Replaceable voice coil
- Magnetically shielded
- Gold-plated terminals
- Flange 54mm sq (2.13")
- Cut-out 44mm Ø (1.73")
- Depth 15.5mm (0.61")

Znom	8 ohm	Sd	6.0 cm <sup>2</sup>
Re	5.2 ohm	BL	2.8 N/A
Le@1kHz	0.05 mH	Vas	- ltrs
fs	1000 Hz	Xmax	- mm peak
Qms	-	VC Ø	28 mm
Qes	-	Sensitivity	
Qts	-	1W / 1m	89 dB
Mms	0.47 g	Nom. Power DIN	80 W
Cms	- mm/N	Net weight	0.08 kg

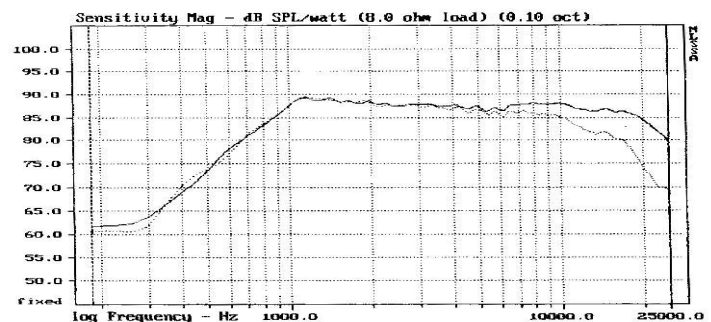

## MDT20 Tweeter



- 1" textile dome tweeter
- Rear chamber
- Replaceable voice coil
- Ferrofluid cooled
- Polymer face-plate
- Low Fs
- Gold plated terminals
- Flange 104mm (4.09")
- Cut-out 73mm (2.87")
- Depth 43mm (1.69")

Znom	8 ohm	Sd	6.0 cm <sup>2</sup>
Re	5.2 ohm	BL	3.5 N/A
Le@1kHz	0.05 mH	Vas	- ltrs
fs	650 Hz	Xmax	- mm peak
Qms	-	VC Ø	28 mm
Qes	-	Sensitivity	
Qts	-	1W / 1m	90 dB
Mms	0.5 g	Nom. Power DIN	120 W
Cms	- mm/N	Net weight	0.55 kg

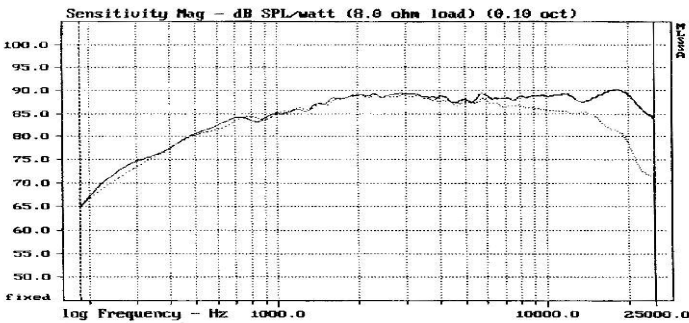

## MDT22 Tweeter



- 1" textile dome tweeter
- Neodymium magnet
- Magnetically shielded
- Rear chamber
- Ferrofluid cooled
- Gold-plated terminals
- Replaceable voice coils
- Flange 54mm sq (2.13")
- Cut-out 44mm Ø (1.73")
- Depth 55mm (2.17")

Znom	8 ohm	Sd	6.0 cm <sup>2</sup>
Re	5.2 ohm	BL	2.8 N/A
Le@1kHz	0.05 mH	Vas	- ltrs
fs	650 Hz	Xmax	- mm peak
Qms	0.89	VC Ø	28 mm
Qes	-	Sensitivity	
Qts	-	1W / 1m	89 dB
Mms	0.47 g	Nom. Power DIN	80 W
Cms	- mm/N	Net weight	0.09 kg

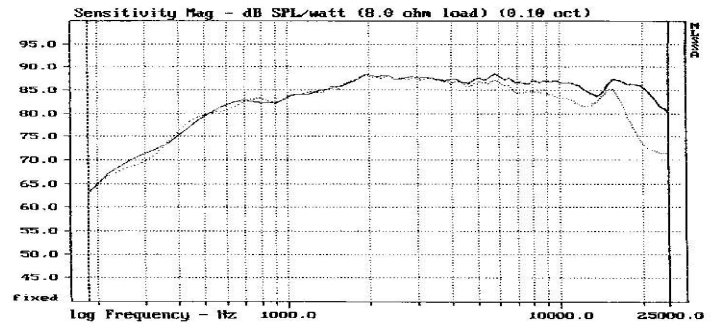

## MDT29 Tweeter



- 1" textile dome tweeter
- Ferrofluid cooled
- Replaceable voice coil
- Aluminum face-plate
- Hand treated dome
- Gold-plated terminals
- Flange 94mm (3.7")
- Cut-out 78mm (2.83")
- Depth 27mm (1.06")

Znom	8 ohm	Sd	6.0 cm <sup>2</sup>
Re	5.2 ohm	BL	3.3 N/A
Le@1kHz	0.05 mH	Vas	- ltrs
fs	900 Hz	Xmax	- mm peak
Qms	-	VC Ø	28 mm
Qes	-	Sensitivity	
Qts	-	1W / 1m	89 dB
Mms	0.5 g	Nom. Power DIN	80 W
Cms	- mm/N	Net weight	0.54 kg

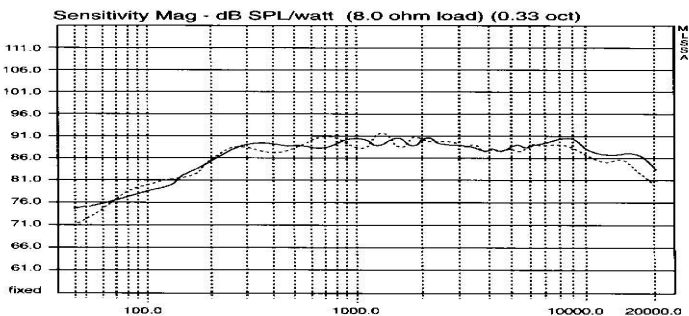

## MDT30S Tweeter



- 1" textile dome tweeter
- Hand coated dome
- Ferrofluid cooled
- Replaceable voice coils
- Aluminum face-plate
- Gold-plated terminals
- Rear chamber
- Flange 94mm (3.7")
- Cut-out Ø 73mm (2.87")
- Depth 43mm (1.69")

Znom	8 ohm	Sd	6.0 cm <sup>2</sup>
Re	5.2 ohm	BL	3.5 N/A
Le@1kHz	0.09 mH	Vas	- ltrs
fs	650 Hz	Xmax	- mm peak
Qms	-	VC Ø	28 mm
Qes	-	Sensitivity	
Qts	-	1W / 1m	90 dB
Mms	0.44 g	Nom. Power DIN	200 W
Cms	- mm/N	Net weight	0.56 kg

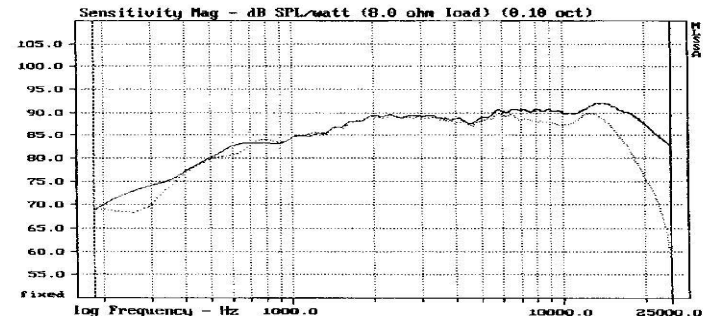



## MDT32S Tweeter



- 1" textile dome tweeter
- Hand coated dome
- Ferrofluid cooled
- Replaceable voice coils
- Aluminum face-plate
- Gold-plated terminals
- Rear chamber
- Flange 110mm (4.33")
- Cut-out Ø 73mm (2.87")
- Depth 43mm (1.69")

Znom	8 ohm	Sd	6.0 cm <sup>2</sup>
Re	5.2 ohm	BL	3.5 N/A
Le@1kHz	0.09 mH	Vas	- ltrs
fs	650 Hz	Xmax	- mm peak
Qms	-	VC Ø	28 mm
Qes	-	Sensitivity	
Qts	-	1W / 1m	90 dB
Mms	0.44 g	Nom. Power DIN	200 W
Cms	- mm/N	Net weight	0.56 kg

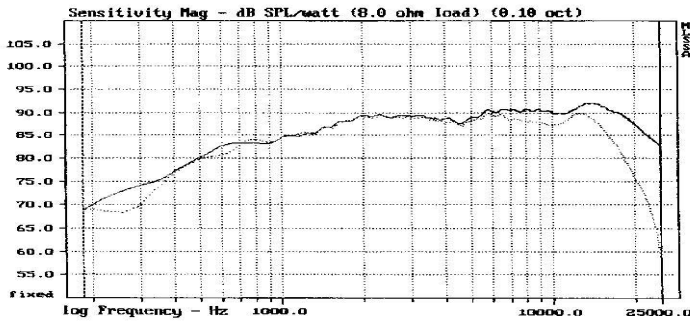

## DMS30S Tweeter



- 1" textile dome tweeter
- Hand coated dome
- Ferrofluid cooled
- Replaceable voice coil
- Gold-plated terminals
- Magnetically shielded
- Rear chamber
- Flange 94mm (3.7")
- Cut-out 73mm (2.87")
- Depth 43mm (1.69")

Znom	8 ohm	Sd	6.0 cm <sup>2</sup>
Re	5.2 ohm	BL	3.5 N/A
Le@1kHz	0.05 mH	Vas	- ltrs
fs	650 Hz	Xmax	- mm peak
Qms	-	VC Ø	28 mm
Qes	-	Sensitivity	
Qts	-	1W / 1m	90 dB
Mms	0.44 g	Nom. Power DIN	200 W
Cms	- mm/N	Net weight	0.66 kg

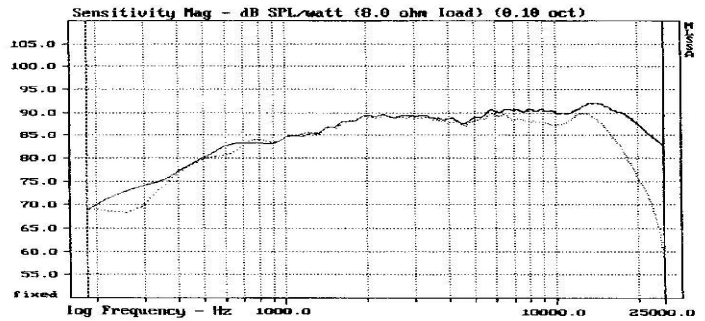

## MDT33 Tweeter



- 1" treated textile dome
- Triple magnet system
- Hexatech voice coil
- Aluminum face-plate
- Ferrofluid cooling
- Rear chamber
- Replaceable voice coil
- Flange 110mm (4.33")
- Cut-out 74mm (2.91")
- Depth 63mm (2.48")

Znom	8 ohm	Sd	6.0 cm <sup>2</sup>
Re	5.2 ohm	BL	6.3 N/A
Le@1kHz	0.09 mH	Vas	- ltrs
fs	700 Hz	Xmax	- mm peak
Qms	-	VC Ø	28 mm
Qes	-	Sensitivity	
Qts	-	1W / 1m	92.5 dB
Mms	0.44 g	Nom. Power DIN	200 W
Cms	- mm/N	Net weight	1.2 kg

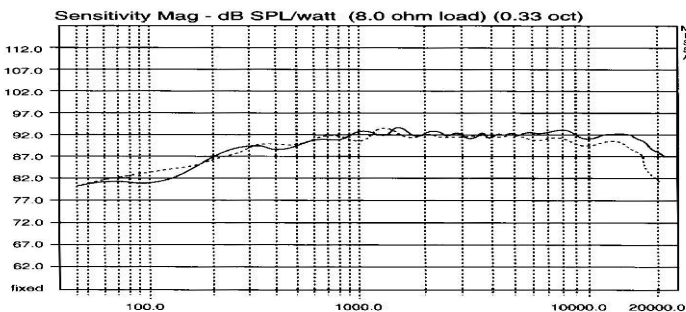

## MDT37 Tweeter



- 1" textile dome tweeter
- Horn loaded face-plate
- Hexatech voice coil
- Ferrofluid cooled
- Replaceable voice coil
- Gold-plated terminals
- High efficiency
- Flange 94mm (3.7")
- Cut-out 72mm (2.83")
- Depth 54mm (2.28")

Znom	8 ohm	Sd	6.0 cm <sup>2</sup>
Re	5.2 ohm	BL	3.5 N/A
Le@1kHz	0.09 mH	Vas	- ltrs
fs	700 Hz	Xmax	- mm peak
Qms	-	VC Ø	28 mm
Qes	-	Sensitivity	
Qts	-	1W / 1m	93 dB
Mms	0.44 g	Nom. Power DIN	200 W
Cms	- mm/N	Net weight	0.56 kg

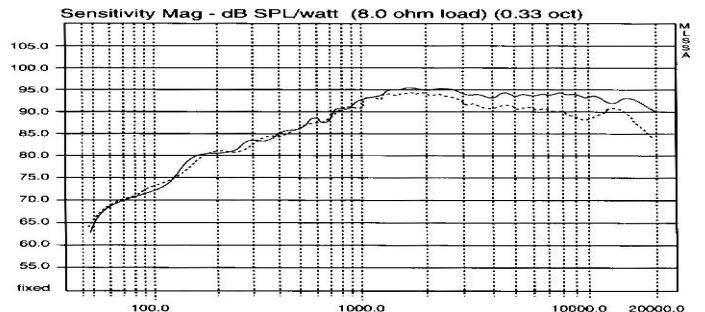

## MDT38 Tweeter



- 1" textile dome tweeter
- Top-Mount design
- Neodymium magnet
- Magnetically shielded
- Rear chamber
- Protective grill
- Ferrofluid cooled
- Flange 44mm (1.73")
- Depth 58mm (2.28")

Znom	8 ohm	Sd	7.0 cm <sup>2</sup>
Re	5.2 ohm	BL	2.6 N/A
Le@1kHz	0.06 mH	Vas	- ltrs
fs	750 Hz	Xmax	- mm peak
Qms	-	VC Ø	28 mm
Qes	-	Sensitivity	
Qts	-	1W / 1m	89 dB
Mms	0.46 g	Nom. Power DIN	80 W
Cms	- mm/N	Net weight	0.09 kg

## MDT39 Tweeter



- 1" textile dome tweeter
- Compact size
- Neodymium magnet
- Rear chamber
- Ferrofluid cooled
- Magnetically shielded
- Smooth response
- Flange 54mm sq (2.13")
- Cut-out 44mm Ø (1.73")
- Depth 55mm (2.17")

Znom	8 ohm	Sd	7.0 cm <sup>2</sup>
Re	5.2 ohm	BL	2.6 N/A
Le@1kHz	0.06 mH	Vas	- ltrs
fs	750 Hz	Xmax	- mm peak
Qms	-	VC Ø	28 mm
Qes	-	Sensitivity	
Qts	-	1W / 1m	88 dB
Mms	0.46 g	Nom. Power DIN	80 W
Cms	- mm/N	Net weight	0.09 kg

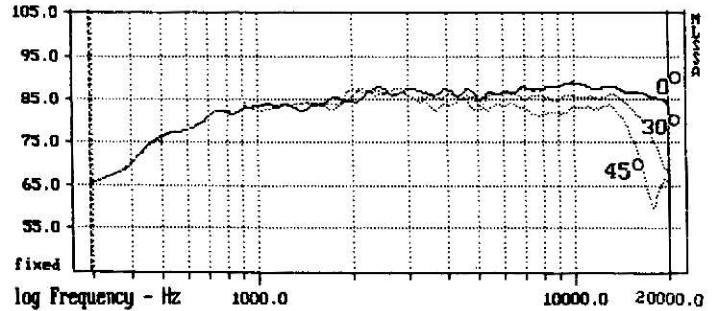
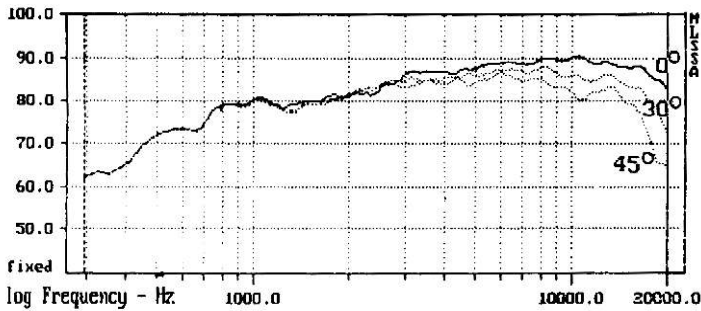

## MDT40 Tweeter



- 1" textile dome tweeter
- Hexatech voice coil
- Neodymium magnet
- Rear chamber
- Replaceable voice coil
- Ferrofluid cooled
- Magnetically shielded
- Flange 54mm sq (2.13")
- Cut-out 44mm Ø (1.73")
- Depth 55mm (2.17")

Znom	8 ohm	Sd	7.0 cm <sup>2</sup>
Re	5.2 ohm	BL	2.9 N/A
Le@1kHz	0.05 mH	Vas	- ltrs
fs	750 Hz	Xmax	- mm peak
Qms	-	VC Ø	28 mm
Qes	-	Sensitivity	
Qts	-	1W / 1m	89 dB
Mms	0.46 g	Nom. Power DIN	120 W
Cms	- mm/N	Net weight	0.09 kg

## MDT41 Tweeter



- 1" textile dome tweeter
- Top-mount design
- Hexatech voice coil
- Neodymium magnet
- Magnetically shielded
- Rear chamber
- Ferrofluid cooled
- Flange 44mm (1.73")
- Depth 58mm (2.28")

Znom	8 ohm	Sd	6.0 cm <sup>2</sup>
Re	5.2 ohm	BL	2.9 N/A
Le@1kHz	0.05 mH	Vas	- ltrs
fs	750 Hz	Xmax	- mm peak
Qms	-	VC Ø	28 mm
Qes	-	Sensitivity	
Qts	-	1W / 1m	90 dB
Mms	0.46 g	Nom. Power DIN	120 W
Cms	- mm/N	Net weight	0.09 kg

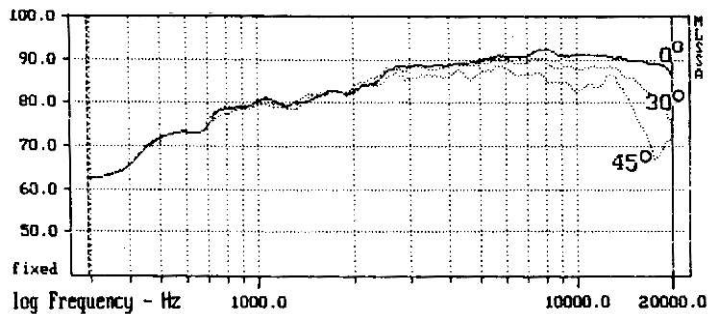
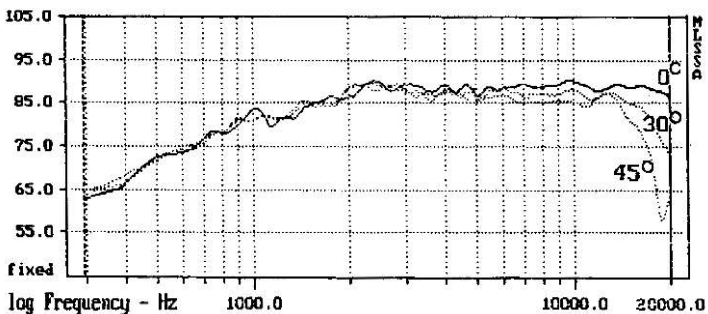



## MDT43 Tweeter



- 1" textile dome tweeter
- Top-Mount design
- Double neodymium magnet - Shielded
- Rear chamber
- Ferrofluid cooled
- Hexatech voice coil
- Flange 44mm (1.73")
- Depth 58mm (2.28")

Znom	8 ohm	Sd	7.0 cm <sup>2</sup>
Re	5.2 ohm	BL	4.3 N/A
Le@1kHz	0.06 mH	Vas	- ltrs
fs	750 Hz	Xmax	- mm peak
Qms	-	VC Ø	28 mm
Qes	-	Sensitivity	
Qts	-	1W / 1m	92 dB
Mms	0.46 g	Nom. Power DIN	120 W
Cms	- mm/N	Net weight	0.09 kg

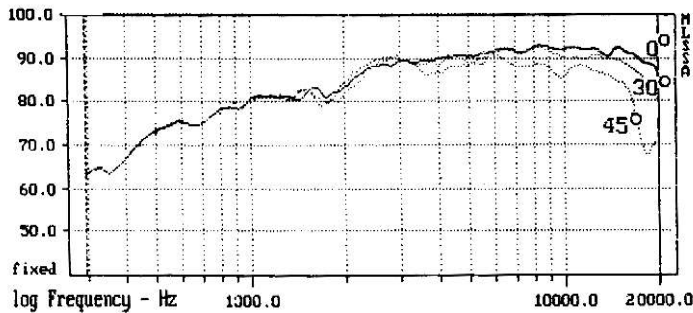

## MDT44 Tweeter



- 1" textile dome tweeter
- Hexatech voice coil
- Double neodymium magnet - Shielded
- Rear chamber
- Replaceable voice coil
- Ferrofluid cooled
- Flange 54mm sq (2.13")
- Cut-out 44mm Ø (1.73")
- Depth 55mm (2.17")

Znom	8 ohm	Sd	7.0 cm <sup>2</sup>
Re	5.1 ohm	BL	4.3 N/A
Le@1kHz	0.05 mH	Vas	- ltrs
fs	750 Hz	Xmax	- mm peak
Qms	-	VC Ø	28 mm
Qes	-	Sensitivity	
Qts	-	1W / 1m	91 dB
Mms	0.46 g	Nom. Power DIN	120 W
Cms	- mm/N	Net weight	0.09 kg

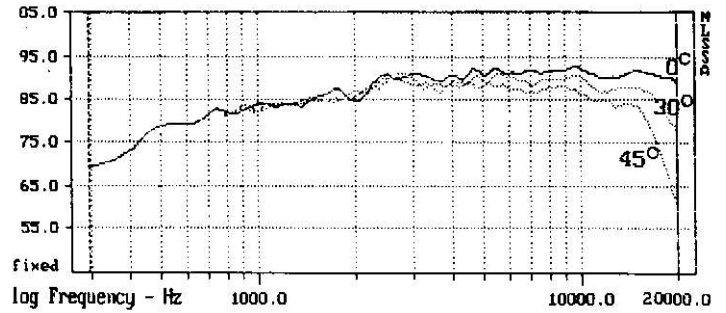

## MDM55 Midrange



- 2" textile dome midrange
- Neodymium magnet
- Rear chamber
- Magnetically shielded
- Gold-plated terminals
- Hexatech voice coil
- Flange 87mm sq (3.43")
- Cut-out 75mm Ø (2.95")
- Depth 82mm (3.23")

Znom	8 ohm	Sd	28.0 cm <sup>2</sup>
Re	6.3 ohm	BL	5.2 N/A
Le@1kHz	0.19 mH	Vas	- ltrs
fs	380 Hz	Xmax	1.0 mm peak
Qms	-	VC Ø	54 mm
Qes	-	Sensitivity	
Qts	-	1W / 1m	90.5 dB
Mms	2.2 g	Nom. Power DIN	200 W
Cms	- mm/N	Net weight	0.3 kg

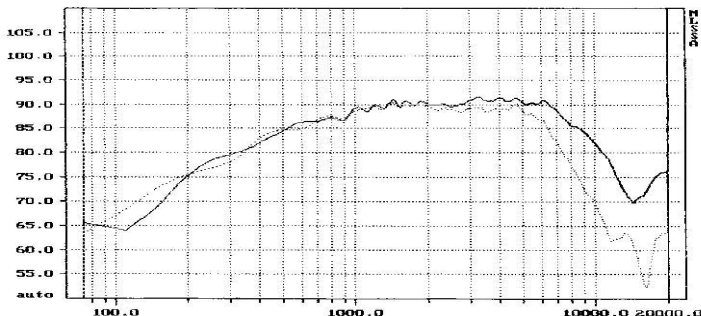

## MW113 4" Woofer



- 4" Damped Polymer Composite cone
- 54mm Hexatech voice coil
- Rubber surround
- Triple magnet system
- Magnetically shielded
- Flange 118mm (4.64")
- Cut-out 95mm (3.75")
- Depth 58mm (2.28")

Znom	8 ohm	Sd	53.0 cm <sup>2</sup>
Re	6.2 ohm	BL	3.98 N/A
Le@1kHz	0.25 mH	Vas	4.3 ltrs
fs	72 Hz	Xmax	3.0 mm peak
Qms	3.13	VC Ø	54 mm
Qes	1.03	Sensitivity	
Qts	0.75	1W / 1m	87 dB
Mms	5.54 g	Nom. Power DIN	150 W
Cms	0.84 mm/N	Net weight	0.5 kg

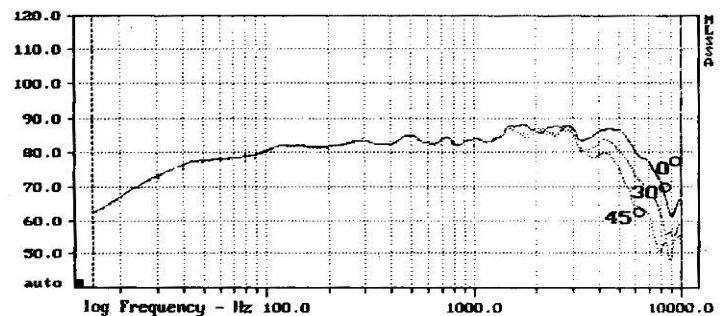



## MW114-S 4" Woofer



- 4" Damped Polymer Composite cone
- Neodymium magnet
- Hexatech voice coil
- Shielded magnet
- Rubber surround
- Small & powerful
- Flange 118mm (4.64")
- Cut-out 94mm (3.7")
- Depth 58mm (2.28")

Znom	8 ohm	Sd	53.0 cm <sup>2</sup>
Re	5.6 ohm	BL	6.57 N/A
Le@1kHz	0.36 mH	Vas	1.80 ltrs
fs	80 Hz	Xmax	3.0 mm peak
Qms	3.56	VC Ø	54 mm
Qes	0.67	Sensitivity	
Qts	0.56	1W / 1m	87 dB
Mms	6.55 g	Nom. Power DIN	150 W
Cms	0.44 mm/N	Net weight	0.5 kg

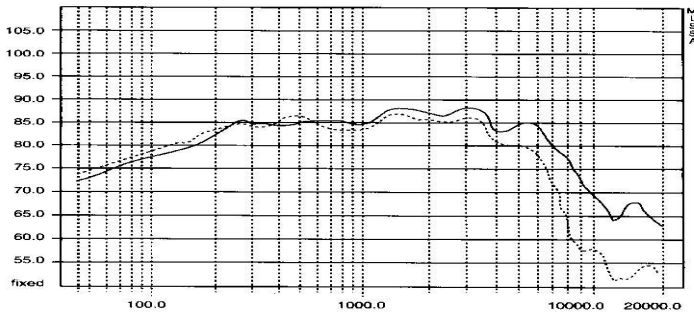

## MW144 5" Woofer



- 5" Damped Polymer Composite cone
- Double magnet
- Hexatech voice coil
- Vented magnet system
- Rubber surround
- Low magnetic field
- Flange 142mm (5.59")
- Cut-out 118mm (4.65")
- Depth 52mm (2.04")

Znom	8 ohm	Sd	90.0 cm <sup>2</sup>
Re	5.2 ohm	BL	6.2 N/A
Le@1kHz	0.38 mH	Vas	8.0 ltrs
fs	52 Hz	Xmax	3.5 mm peak
Qms	2.44	VC Ø	75 mm
Qes	0.71	Sensitivity	
Qts	0.55	1W / 1m	88 dB
Mms	13.7 g	Nom. Power DIN	150 W
Cms	0.69 mm/N	Net weight	1.0 kg

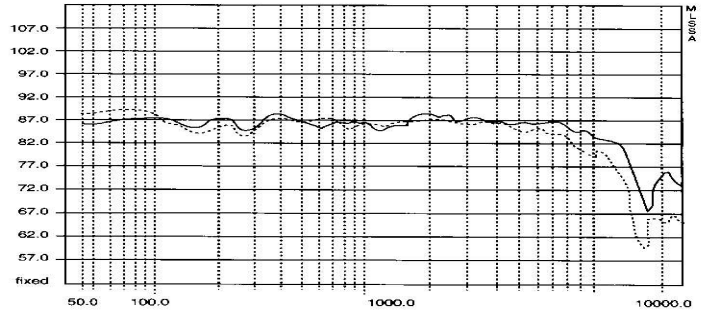

## MW164 6" Woofer



- 6" Polymer coated paper cone
- Double magnet
- Hexatech voice coil
- Rubber surround
- Low magnetic field
- Ventilated spider
- Flange 160mm (6.3")
- Cut-out 136mm (5.4")
- Depth 67mm (2.63")

Znom	8 ohm	Sd	119.0 cm <sup>2</sup>
Re	6.3 ohm	BL	6.57 N/A
Le@1kHz	0.66 mH	Vas	14.34 ltrs
fs	48 Hz	Xmax	4.25 mm peak
Qms	2.55	VC Ø	75 mm
Qes	0.70	Sensitivity	
Qts	0.55	1W / 1m	86 dB
Mms	14.9 g	Nom. Power DIN	150 W
Cms	0.69 mm/N	Net weight	1.1 kg

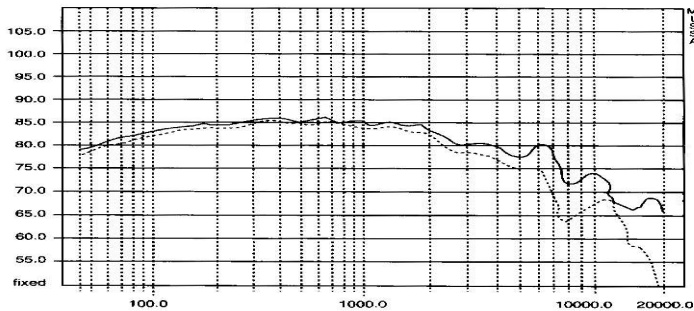

## MW166 6" Woofer



- 6" Damped polymer composite cone
- Double magnet
- Hexatech voice coil
- Rubber surround
- Low magnetic field
- Ventilated spider
- Flange 160mm (6.3")
- Cut-out 136mm (5.4")
- Depth 67mm (2.63")

Znom	8 ohm	Sd	119.0 cm <sup>2</sup>
Re	6.7 ohm	BL	6.84 N/A
Le@1kHz	0.61 mH	Vas	15.6 ltrs
fs	46 Hz	Xmax	4.25 mm peak
Qms	2.79	VC Ø	75 mm
Qes	0.74	Sensitivity	
Qts	0.58	1W / 1m	86 dB
Mms	16.3 g	Nom. Power DIN	150 W
Cms	0.78 mm/N	Net weight	1.1 kg

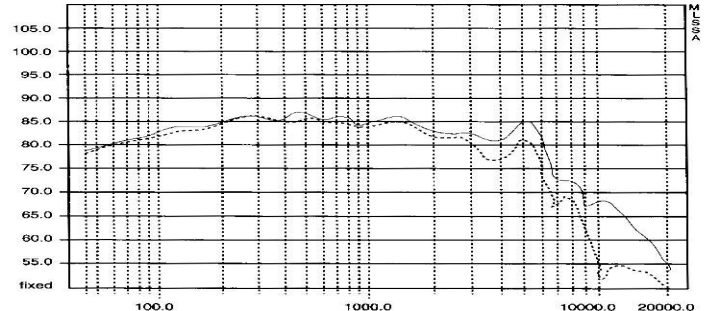

## MW168 6" Woofer



- 6" Damped polymer composite cone
- Double magnet
- Hexatech voice coil
- Rubber surround
- Low magnetic field
- Ventilated spider
- Flange 160mm (6.3")
- Cut-out 136mm (5.4")
- Depth 58mm (2.28")

Znom	8 ohm	Sd	119.0 cm <sup>2</sup>
Re	5.2 ohm	BL	6.55 N/A
Le@1kHz	0.51 mH	Vas	16.0 ltrs
fs	44 Hz	Xmax	3.5 mm peak
Qms	2.09	VC Ø	75 mm
Qes	0.50	Sensitivity	
Qts	0.41	1W / 1m	88 dB
Mms	14.0 g	Nom. Power DIN	150 W
Cms	0.80 mm/N	Net weight	0.80 kg

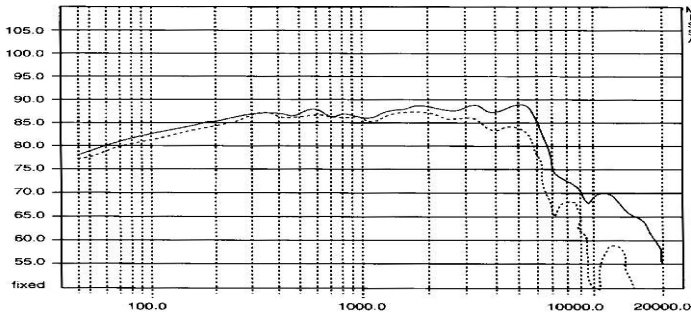

## MW265 8" Woofer



- 8" Damped polymer composite cone
- Rubber surround
- Hexatech voice coil
- Double magnet
- Shallow profile
- Low magnetic field
- Flange 222mm (8.75")
- Cut-out 195mm (7.68")
- Depth 69mm (2.7")

Znom	8 ohm	Sd	219.0 cm <sup>2</sup>
Re	5.2 ohm	BL	6.3 N/A
Le@1kHz	0.58 mH	Vas	61 ltrs
fs	30 Hz	Xmax	3.5 mm peak
Qms	2.79	VC Ø	75 mm
Qes	0.79	Sensitivity	
Qts	0.61	1W / 1m	89 dB
Mms	25.5 g	Nom. Power DIN	150 W
Cms	0.92 mm/N	Net weight	1.2 kg

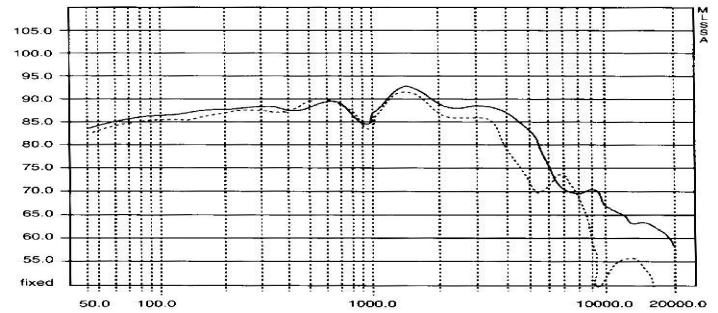

## MW266 8" Woofer



- 8" Polymer coated paper cone
- Rubber surround
- Hexatech voice coil
- Double magnet
- Shallow profile
- Low magnetic field
- Flange 222mm (8.75")
- Cut-out 195mm (7.68")
- Depth 69mm (2.7")

Znom	8 ohm	Sd	219.0 cm <sup>2</sup>
Re	6.3 ohm	BL	6.25 N/A
Le@1kHz	0.54 mH	Vas	80 ltrs
fs	29 Hz	Xmax	4.25 mm peak
Qms	2.45	VC Ø	75 mm
Qes	0.73	Sensitivity	
Qts	0.56	1W / 1m	89 dB
Mms	24.9 g	Nom. Power DIN	150 W
Cms	1.19 mm/N	Net weight	1.2 kg

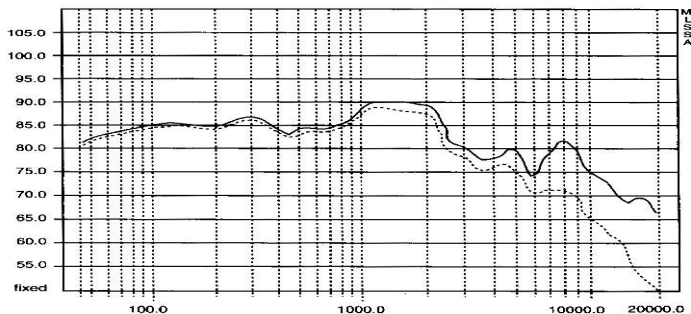

## MW1075 10" Woofer



- 10" Damped polymer composite cone
- Polymer treated foam surround
- Double magnet
- Low magnetic field
- Hexatech voice coil
- Flange 263mm (10.35")
- Cut-out 230mm (9.06")
- Depth 80mm (3.13")

Znom	8 ohm	Sd	324.0 cm <sup>2</sup>
Re	6.3 ohm	BL	6.3 N/A
Le@1kHz	0.63 mH	Vas	123 ltrs
fs	29 Hz	Xmax	4.25 mm peak
Qms	2.48	VC Ø	75 mm
Qes	0.83	Sensitivity	
Qts	0.62	1W / 1m	89 dB
Mms	32.6 g	Nom. Power DIN	180 W
Cms	0.84 mm/N	Net weight	1.34 kg

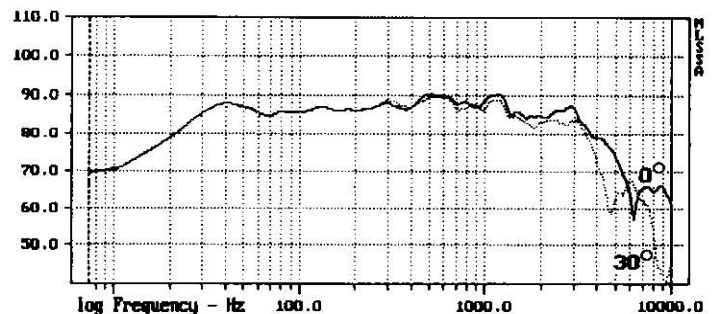



### MW143 5" NeoLin



- 5" Damped polymer cone woofer
- High flux neodymium magnet system
- Hexatech voice coil
- Copper lining of VC gap for flatter inductance
- Flange 142mm (5.5")
- Cut-out 118mm (4.65")
- Depth 52mm (2")

Znom	8 ohm	Sd	90.0 cm <sup>2</sup>
Re	5.3 ohm	BL	7.2 N/A
Le@1kHz	0.6 mH	Vas	9.5 ltrs
fs	52 Hz	Xmax	3.5 mm peak
Qms	2.32	VC Ø	75 mm
Qes	0.43	Sensitivity	
Qts	0.36	1W / 1m	89 dB
Mms	10.4 g	Nom. Power DIN	150 W
Cms	0.83 mm/N	Net weight	0.95 kg

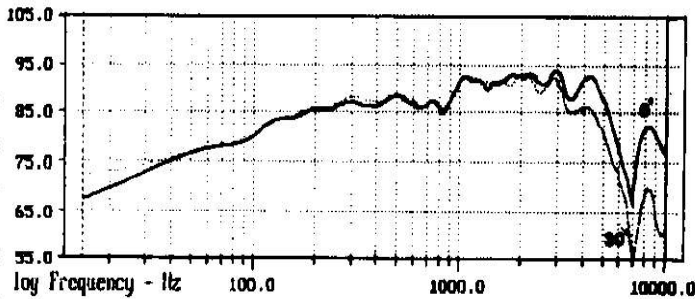

### MW167 6" NeoLin



- 6" Damped polymer cone woofer
- High flux neodymium magnet system
- Hexatech voice coil
- Copper lining of VC gap for flatter inductance
- Flange 160mm (6.3")
- Cut-out 136mm (5.35")
- Depth 65mm (2.55")

Znom	8 ohm	Sd	119.0 cm <sup>2</sup>
Re	6.6 ohm	BL	7.8 N/A
Le@1kHz	0.08 mH	Vas	18.8 ltrs
fs	44 Hz	Xmax	4.25 mm peak
Qms	1.99	VC Ø	75 mm
Qes	0.43	Sensitivity	
Qts	0.35	1W / 1m	88 dB
Mms	14.0 g	Nom. Power DIN	150 W
Cms	0.95 mm/N	Net weight	1.1 kg

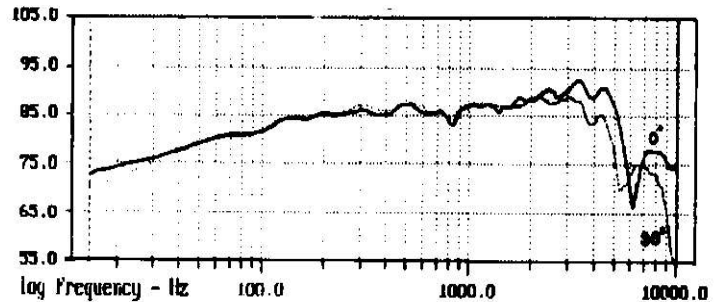

### MW267 8" NeoLin



- 8" Damped polymer cone woofer
- High flux neodymium magnet system
- Hexatech voice coil
- Copper lining of VC gap for flatter inductance
- Flange 222mm (8.75")
- Cut-out 195mm (7.68")
- Depth 69mm (2.7")

Znom	8 ohm	Sd	219.0 cm <sup>2</sup>
Re	6.6 ohm	BL	8.0 N/A
Le@1kHz	0.16 mH	Vas	113 ltrs
fs	25 Hz	Xmax	4.25 mm peak
Qms	2.08	VC Ø	75 mm
Qes	0.40	Sensitivity	
Qts	0.33	1W / 1m	89 dB
Mms	24.0 g	Nom. Power DIN	180 W
Cms	1.68 mm/N	Net weight	1.2 kg

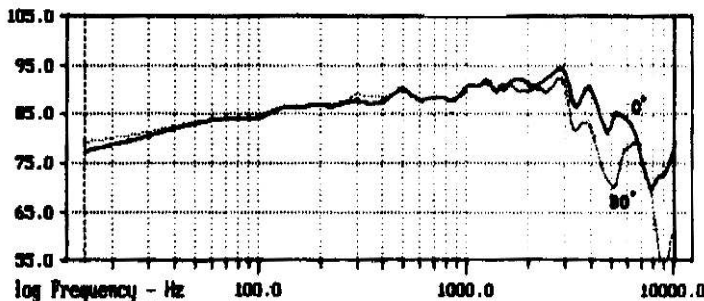

### HU521 5" Uniflow



- 5" Damped polymer composite cone
- Hybrid neodymium / ferrite magnet system
- Low magnetic field
- Hexatech voice coil
- Rubber surround
- Flange 145mm (5.7")
- Cut-out 124mm (4.88")
- Depth 68mm (2.68")

Znom	8 ohm	Sd	84.0 cm <sup>2</sup>
Re	5.6 ohm	BL	6.6 N/A
Le@1kHz	0.53 mH	Vas	9.9 ltrs
fs	46 Hz	Xmax	3.5 mm peak
Qms	2.24	VC Ø	54 mm
Qes	0.46	Sensitivity	
Qts	0.37	1W / 1m	88 dB
Mms	12.2 g	Nom. Power DIN	160 W
Cms	0.98 mm/N	Net weight	1.1 kg

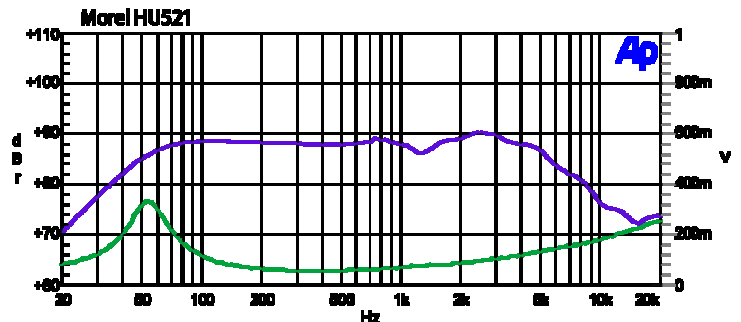



## HU531 5" Uniflow



- 5" Damped polymer composite cone
- Hybrid neodymium / ferrite magnet system
- Low magnetic field
- Hexatech voice coil
- Rubber surround
- Flange 145mm (5.7")
- Cut-out 124mm (4.88")
- Depth 68mm (2.68")

Znom	8 ohm	Sd	84.0 cm <sup>2</sup>
Re	6.8 ohm	BL	7.2 N/A
Le@1kHz	0.63 mH	Vas	9.9 ltrs
fs	46 Hz	Xmax	3.5 mm peak
Qms	1.84	VC Ø	75 mm
Qes	0.46	Sensitivity	
Qts	0.37	1W / 1m	86 dB
Mms	12.2 g	Nom. Power DIN	180 W
Cms	0.98 mm/N	Net weight	1.15 kg

## HU621 6" Uniflow



- 6" Damped polymer composite cone
- Hybrid neodymium / ferrite magnet system
- Low magnetic field
- Hexatech voice coil
- Rubber surround
- Flange 160mm (6.3")
- Cut-out 141mm (5.55")
- Depth 68mm (2.68")

Znom	8 ohm	Sd	119.0 cm <sup>2</sup>
Re	5.6 ohm	BL	5.9 N/A
Le@1kHz	0.53 mH	Vas	27.0 ltrs
fs	43 Hz	Xmax	3.5 mm peak
Qms	2.34	VC Ø	54 mm
Qes	0.45	Sensitivity	
Qts	0.38	1W / 1m	90 dB
Mms	10.0 g	Nom. Power DIN	160 W
Cms	1.34 mm/N	Net weight	1.2 kg

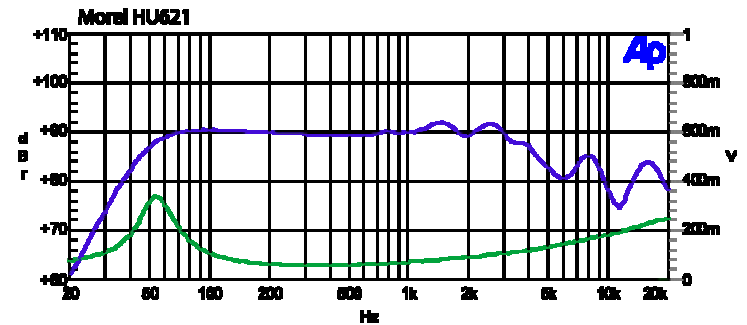
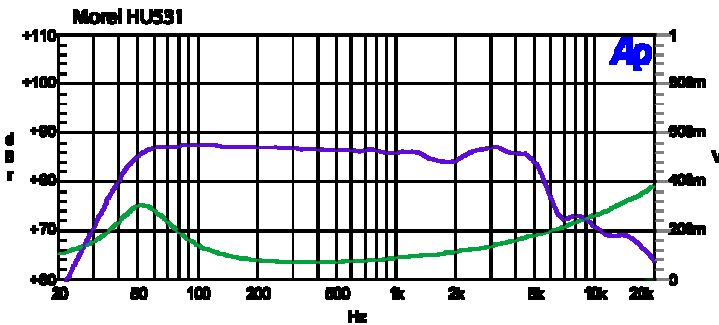

## HU631 6" Uniflow



- 6" Damped polymer composite cone
- Hybrid neodymium / ferrite magnet system
- Low magnetic field
- Hexatech voice coil
- Rubber surround
- Flange 160mm (6.3")
- Cut-out 141mm (5.5")
- Depth 68mm (2.68")

Znom	8 ohm	Sd	119.0 cm <sup>2</sup>
Re	6.8 ohm	BL	7.5 N/A
Le@1kHz	0.63 mH	Vas	16.9 ltrs
fs	44 Hz	Xmax	4.25 mm peak
Qms	1.66	VC Ø	75 mm
Qes	0.46	Sensitivity	
Qts	0.36	1W / 1m	88 dB
Mms	13.6 g	Nom. Power DIN	180 W
Cms	0.96 mm/N	Net weight	1.18 kg

## HU9.1 8" Uniflow



- 8" Damped polymer composite cone
- Hybrid neodymium / ferrite magnet system
- Hexatech voice coil
- Rubber surround
- Low magnetic field
- Flange 222mm (8.75")
- Cut-out 199mm (7.83")
- Depth 70mm (2.75")

Znom	8 ohm	Sd	219.0 cm <sup>2</sup>
Re	6.6 ohm	BL	8.3 N/A
Le@1kHz	0.87 mH	Vas	71.0 ltrs
fs	30 Hz	Xmax	4.25 mm peak
Qms	1.71	VC Ø	75 mm
Qes	0.46	Sensitivity	
Qts	0.36	1W / 1m	89 dB
Mms	23.5 g	Nom. Power DIN	200 W
Cms	1.055mm/N	Net weight	1.42 kg

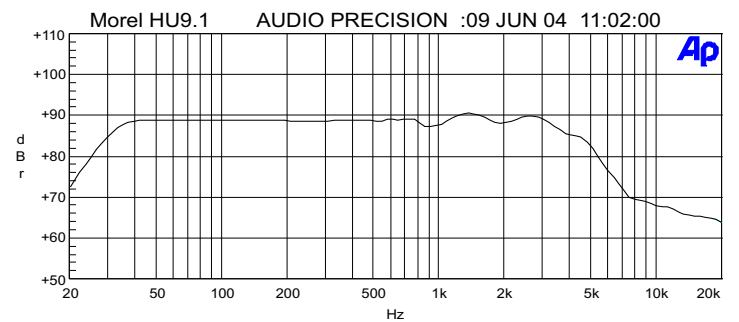
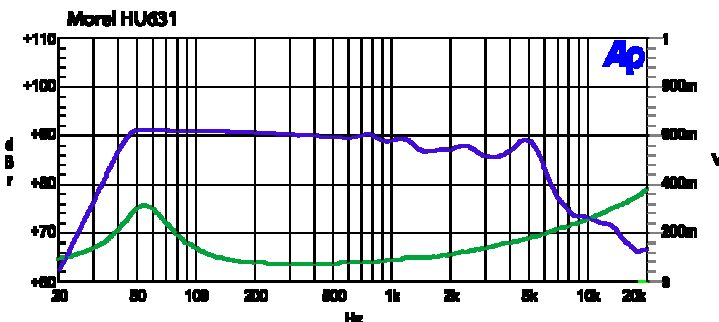



# MAD1259

## High Performance 12" Woofer (4Ω)

Madisound Speakers is pleased to offer the MAD1259 custom made woofer. The unique characteristics of the MAD1259 allow it to be used in a sealed enclosures, producing deep and accurate bass to 25Hz. The large voice coil and long excursion insure that this woofer will provide superior transient response with exceptional power handling. The bumped backplate and raised spider prevent bottoming at maximum excursions; the heavy cast frame minimizes energy transfer to the enclosure; and the polypropylene cone with rubber surround promise long term durability in any environment. This woofer is an exceptional choice for any high-end home or autosound system and can also handle the most demanding A/V system.

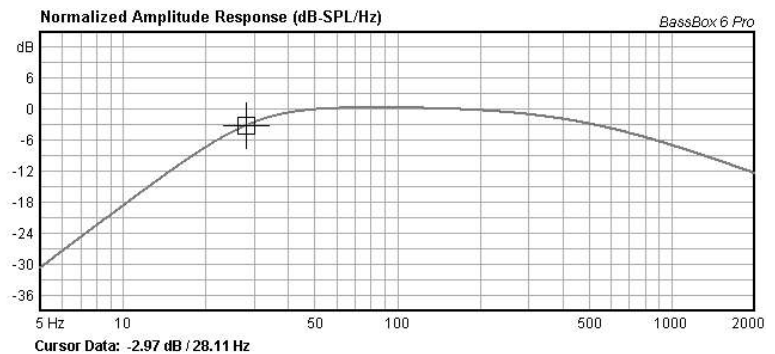
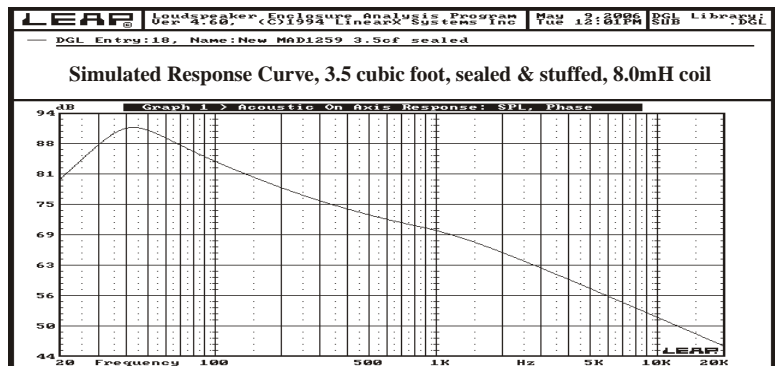
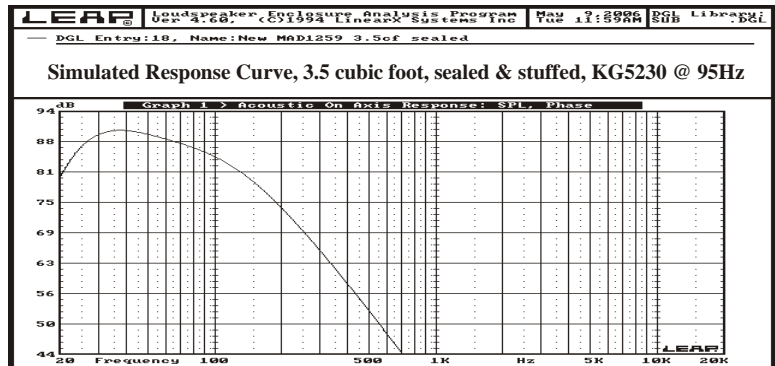
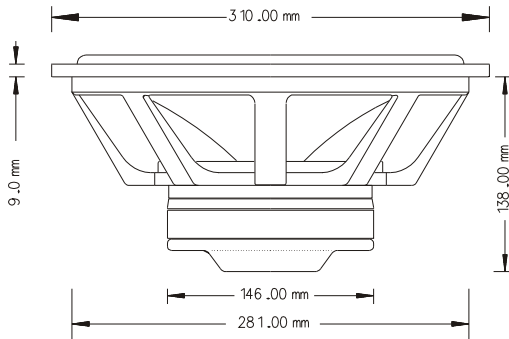

**Simulated Response Curve, 3.0 cubic foot, two MAD1259 woofers in series, compound loaded (piggyback), sealed and stuffed. About 85dB**

The MAD1259 is the latest version of the famous NHT1259 woofer. The woofer is still made by Foster, but some of the original parts are no longer available. Since the new driver is not similar enough to the old driver, we have changed the name.

Specifications		
Fs	20.13	Hz
Nominal Impedance	4	Ω
Mmd	104.33	Grams
Cms	565.17	m/n
Vas	195.1	Liters
Re	3.524	Ω
Leap Krm	4.033	m Ω
Leap Kxm	11.829	mH
Leap Erm	0.756	
Leap Exm	0.727	
vcL	1.09	mH@1K
Bl	8.472	Tm
Qms	4.413	
Qes	0.663	
Qts	0.576	
Voice Coil Height	34	mm
Air Gap Height	8	mm
Xmax	13.0	mm Peak
SD	0.0493	m <sup>2</sup>
Surround	Rubber	
Frame	Cast	
Cone Material	Polypropylene	
Magnet	59 oz.	
Voice Coil	50 mm	
Music Power	300 Watts	
Sensitivity	89 dB	2.83V/1m
<b>Price</b>	<b>\$150.00</b>	





## 810921 1" HDS Dome Tweeter



- 104mm flange
- 1" textile dome
- Low compression magnet system, vented
- Ferrofluid cooled
- Replaceable voice coil
- 79mm cut out
- **Preliminary Specs**

Znom	8	ohm	Sd	-	cm <sup>2</sup>
Re	5.6	ohm	BL	-	N/A
Le	-	mH	Vas	-	ltrs
fs	700	Hz	Xmax	0.5	mm peak
Qms	-		Sensitivity		
Qes	-		2.83V / 1m	93	dB
Qts	-		Longterm Max		
Mms	-	g	System Power	-	W
Cms	-	mm/N	Magnet weight	-	kg

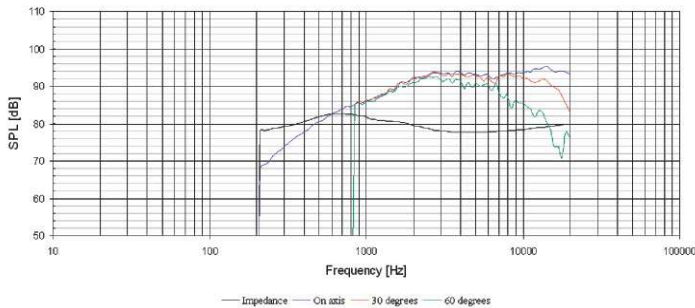

## 821615 4" Poly Cone Midrange



- Chambered back
- 123mm squarish aluminum frame
- Integrated one piece poly cone and surround
- Ferrofluid cooled
- Smooth response
- 105mm depth
- 106mm cut out

Znom	8	ohm	Sd	72.0	cm <sup>2</sup>
Re	6.2	ohm	BL	7.4	N/A
Le	0.3	mH	Vas	-	ltrs
fs	530	Hz	Xmax	2.0	mm peak
Qms	1.07		Sensitivity		
Qes	2.16		2.83V / 1m	91	dB
Qts	0.72		Longterm Max		
Mms	5.73	g	System Power	180	W
Cms	0.02	mm/N	Magnet weight	0.24	kg

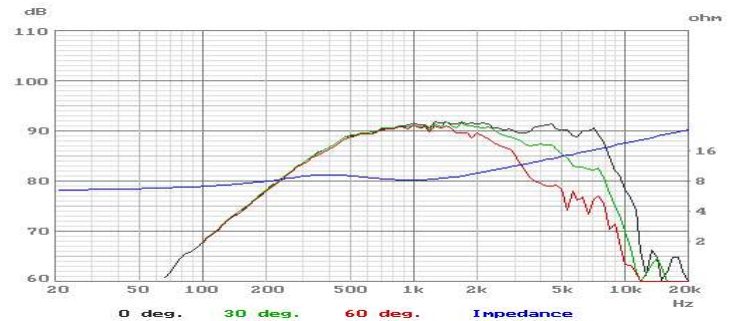

## 830881 4" Exclusive Woofer



- Nomex fiber cone
- Rubber surround
- Cast frame - silver color
- Ventilated raised spider
- Shorting rings
- 120.5mm flange
- 106.5mm truncated
- 95mm cut out
- 53.5mm depth

Znom	8	ohm	Sd	53	cm <sup>2</sup>
Re	5.9	ohm	BL	6.4	N/A
Le	1.0	mH	Vas	2.0	ltrs
fs	81.2	Hz	Xmax	3.5	mm peak
Qms	2.31		Voice Coil Ø	26	mm
Qes	0.55		Sensitivity		
Qts	0.45		2.83V / 1m	84.0	dB
Mms	7.4	g	Power (IEC)		W
Cms	0.52	mm/N	Magnet weight	0.31	kg

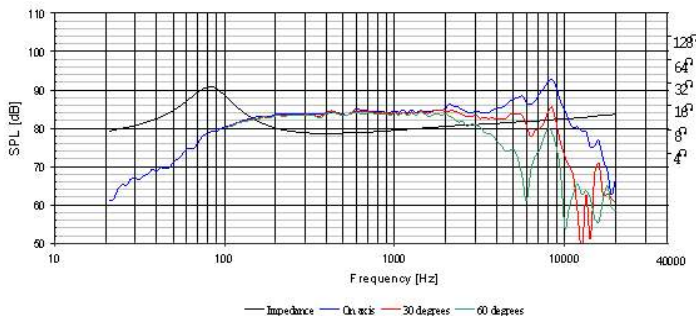

## 830882 5.75" Exclusive Woofer



- Nomex fiber cone
- Rubber surround
- Cast frame - silver color
- Phase plug
- Ventilated raised spider
- Shorting rings
- 152.5mm flange
- 120.5mm cut out
- 61mm depth

Znom	8	ohm	Sd	87	cm <sup>2</sup>
Re	5.9	ohm	BL	7.0	N/A
Le	0.8	mH	Vas	7.2	ltrs
fs	64.5	Hz	Xmax	3.5	mm peak
Qms	3.85		Voice Coil Ø	26	mm
Qes	0.43		Sensitivity		
Qts	0.39		2.83V / 1m	88.2	dB
Mms	8.8	g	Power (IEC)		W
Cms	0.69	mm/N	Magnet weight	0.40	kg

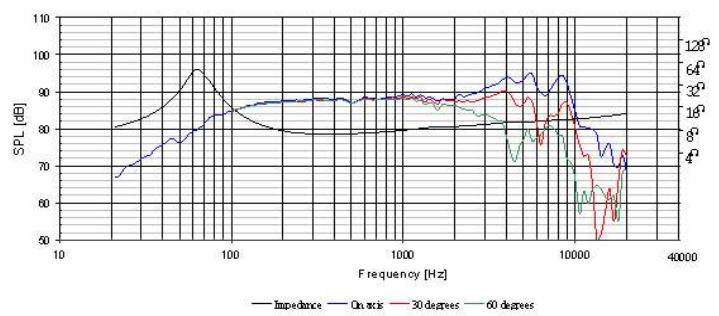

## 830883

## 7" Exclusive Woofer



- Nomex fiber cone
- Phase plug - silver color
- Rubber surround
- Cast frame - silver color
- Ventilated raised spider
- Shorting rings
- 180mm flange
- 147mm cut out
- 78mm depth

Znom	8	ohm	Sd	134	cm <sup>2</sup>
Re	5.8	ohm	BL	8.2	N/A
Le	1.3	mH	Vas	13.0	ltrs
fs	52.3	Hz	Xmax	5.5	mm peak
Qms	2.79		Voice Coil Ø	33	mm
Qes	0.50		Sensitivity	2.83V / 1m	87.5 dB
Qts	0.43		Power (IEC)		W
Mms	17.7	g	Magnet weight	0.68	kg
Cms	0.52	mm/N			

## 830884

## 8" Exclusive Woofer



- Nomex fiber cone
- Rubber surround
- Cast frame - silver color
- Ventilated raised spider
- Shorting rings
- 225mm flange
- 205mm truncated
- 191mm cut out
- 90.5mm depth

Znom	8	ohm	Sd	221	cm <sup>2</sup>
Re	5.8	ohm	BL	8.0	N/A
Le	1.4	mH	Vas	68.8	ltrs
fs	32.4	Hz	Xmax	5.5	mm peak
Qms	3.00		Voice Coil Ø	33	mm
Qes	0.44		Sensitivity	2.83V / 1m	89.3 dB
Qts	0.38		Power (IEC)		W
Mms	23.7	g	Magnet weight	0.68	kg
Cms	1.02	mm/N			

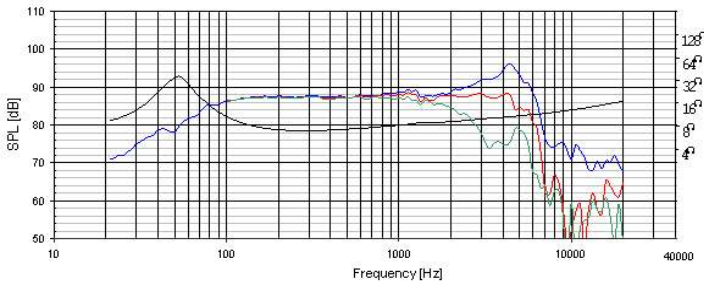

— Impedance — On axis — 30 degrees — 60 degrees

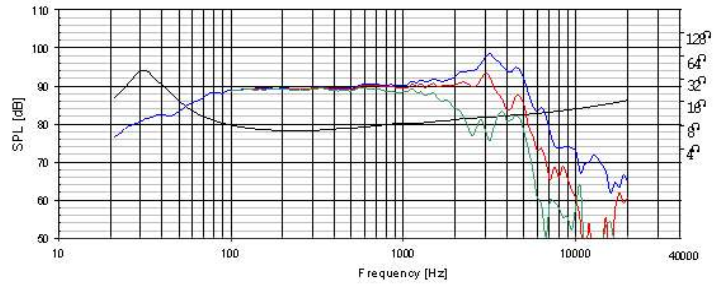

— Impedance — On axis — 30 degrees — 60 degrees

## 830854

## 4" PPB Woofer



- Shielded Magnet
- Polypropylene cone
- Rubber surround
- Cast Frame - truncated
- Ventilated raised spider
- 120.5mm flange
- 106.5mm truncated
- 95mm cut out

Znom	8	ohm	Sd	55	cm <sup>2</sup>
Re	5.3	ohm	BL	5.1	N/A
Le	0.6	mH	Vas	3.2	ltrs
fs	75.7	Hz	Xmax	3	mm peak
Qms	2.66		Voice Coil Ø	26	mm
Qes	0.56		Sensitivity	2.83V / 1m	86.8 dB
Qts	0.46		Power (IEC)		W
Mms	5.9	g	Magnet weight	0.39	kg
Cms	0.76	mm/N			

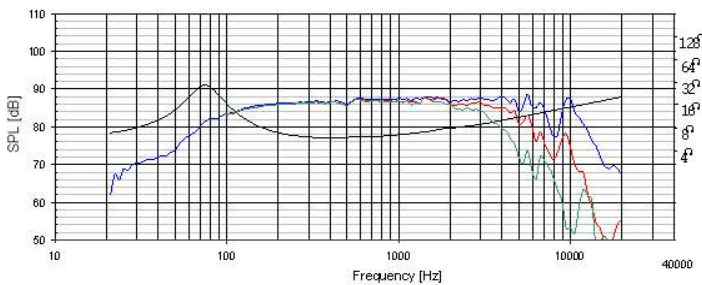

— Impedance — On axis — 30 degrees — 60 degrees

## 830870

## 4" PPB Woofer



- Polypropylene cone
- Rubber surround
- Cast Frame - truncated
- Ventilated raised spider
- Shorting rings
- 120.5mm flange
- 106.5mm truncated
- 95mm cut out
- 55mm depth

Znom	8	ohm	Sd	55	cm <sup>2</sup>
Re	5.2	ohm	BL	4.8	N/A
Le	0.6	mH	Vas	3.0	ltrs
fs	77.6	Hz	Xmax	3	mm peak
Qms	3.19		Voice Coil Ø	26	mm
Qes	0.65		Sensitivity	2.83V / 1m	87.0 dB
Qts	0.54		Power (IEC)		W
Mms	5.9	g	Magnet weight	0.31	kg
Cms	0.72	mm/N			

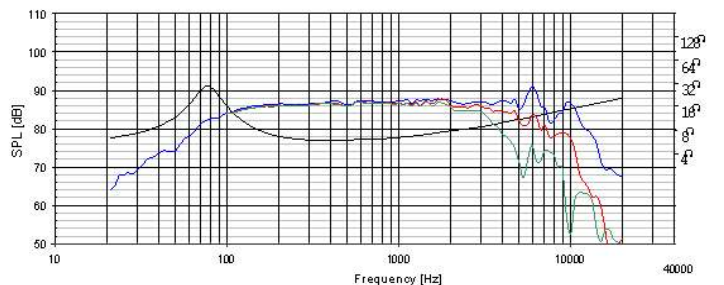

— Impedance — On axis — 30 degrees — 60 degrees

## 830860

## 5.25" PPB Woofer



- Polypropylene cone
- Rubber surround
- Cast Frame - truncated
- Ventilated raised spider
- Shorting rings
- 152mm flange
- 134mm truncated
- 120mm cut out
- 61.5mm depth

Znom	8	ohm	Sd	88	cm <sup>2</sup>
Re	5.7	ohm	BL	5.7	N/A
Le	0.6	mH	Vas	10.6	ltrs
fs	56.1	Hz	Xmax	3.5	mm peak
Qms	2.41		Voice Coil Ø	26	mm
Qes	0.50		Sensitivity		
Qts	0.41		2.83V / 1m	88.3	dB
Mms	8.1	g	Power (IEC)		W
Cms	0.99	mm/N	Magnet weight	0.4	kg

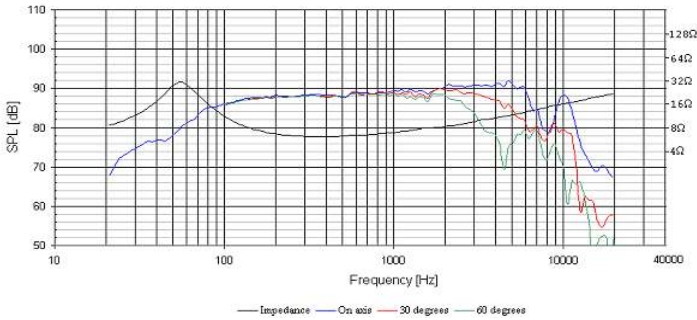

## 830874

## 6.5" PPB Woofer



- Polypropylene cone
- Rubber surround
- Cast Frame - truncated
- Ventilated raised spider
- Shorting rings
- 182mm flange
- 164mm truncated
- 145mm cut out
- 78mm depth

Znom	8	ohm	Sd	139	cm <sup>2</sup>
Re	6.4	ohm	BL	8.5	N/A
Le	1.2	mH	Vas	16.7	ltrs
fs	47.3	Hz	Xmax	5.5	mm peak
Qms	2.73		Voice Coil Ø	33	mm
Qes	0.47		Sensitivity		
Qts	0.40		2.83V / 1m	87.8	dB
Mms	18.1	g	Power (IEC)		W
Cms	0.63	mm/N	Magnet weight	0.68	kg

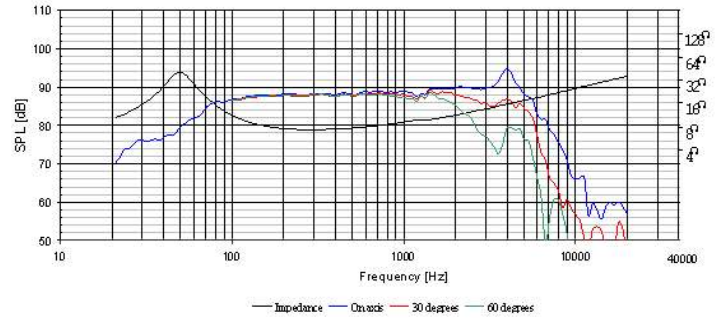

## 830868

## 8" PPB Woofer



- Polypropylene cone
- Rubber surround
- Cast Frame - truncated
- Ventilated raised spider
- Shorting rings
- 225mm flange
- 205mm truncated
- 190mm cut out
- 91mm depth

Znom	8	ohm	Sd	221	cm <sup>2</sup>
Re	5.5	ohm	BL	8.1	N/A
Le	1.5	mH	Vas	63.4	ltrs
fs	32.5	Hz	Xmax	5.5	mm peak
Qms	4.09		Voice Coil Ø	33	mm
Qes	0.44		Sensitivity		
Qts	0.40		2.83V / 1m	90.1	dB
Mms	25.6	g	Power		W
Cms	0.94	mm/N	Magnet weight	0.68	kg

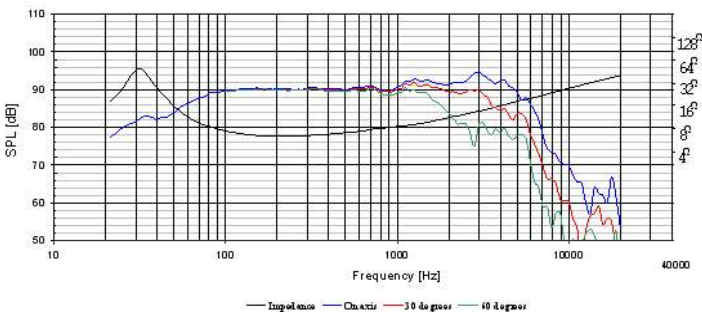

## 830872

## 4" Nomex Woofer



- Shielded magnet
- Nomex fiber cone
- Rubber surround
- Cast Frame - truncated
- Ventilated raised spider
- 120.5mm flange
- 106.5mm truncated
- 95mm cut out

Znom	8	ohm	Sd	55	cm <sup>2</sup>
Re	5.6	ohm	BL	6.1	N/A
Le	0.8	mH	Vas	2.3	ltrs
fs	85.1	Hz	Xmax	2.5	mm peak
Qms	2.19		Voice Coil Ø	26	mm
Qes	0.51		Sensitivity		
Qts	0.42		2.83V / 1m	87.1	dB
Mms	6.4	g	Power (IEC)		W
Cms	0.55	mm/N	Magnet weight	0.39	kg

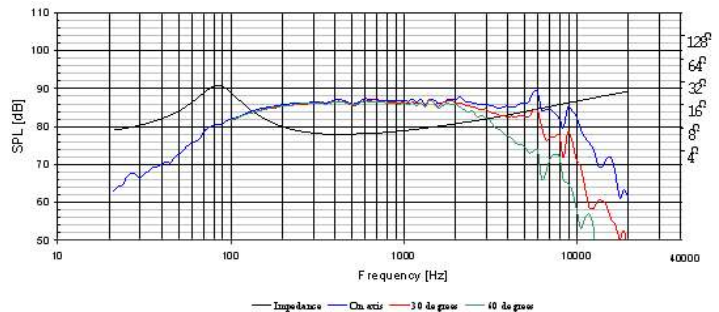



## 830873

## 5.25" Nomex Woofer



- Nomex fiber cone
- Rubber surround
- Cast frame - truncated
- Ventilated raised spider
- Shorting rings
- 152mm flange
- 134mm truncated
- 120mm cut out
- 61.5mm depth

Znom	8	ohm	Sd	88	cm <sup>2</sup>
Re	6	ohm	BL	6.6	N/A
Le	0.8	mH	Vas	8.7	ltrs
fs	58.6	Hz	Xmax	3.5	mm peak
Qms	2.39		Voice Coil Ø	26	mm
Qes	0.46		Sensitivity		
Qts	0.38		2.83V / 1m	88.3	dB
Mms	9.1	g	Power (IEC)		W
Cms	0.81	mm/N	Magnet weight	0.4	kg

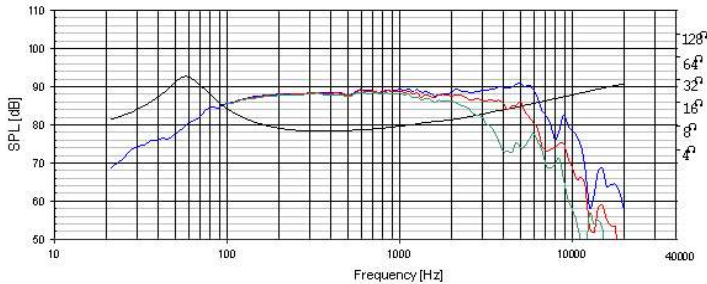

— Impedance — On-axis — 30 degrees — 60 degrees

## 830875

## 6.5" Nomex Woofer



- Nomex fiber cone
- Rubber surround
- Cast frame - truncated
- Ventilated raised spider
- Shorting rings
- 182mm flange
- 164mm truncated
- 145mm cut out
- 78mm depth

Znom	8	ohm	Sd	139	cm <sup>2</sup>
Re	6.4	ohm	BL	8.4	N/A
Le	1.3	mH	Vas	17.6	ltrs
fs	48.1	Hz	Xmax	5.5	mm peak
Qms	2.67		Voice Coil Ø	33	mm
Qes	0.45		Sensitivity		
Qts	0.39		2.83V / 1m	88.6	dB
Mms	16.6	g	Power (IEC)		W
Cms	0.66	mm/N	Magnet weight	0.68	kg

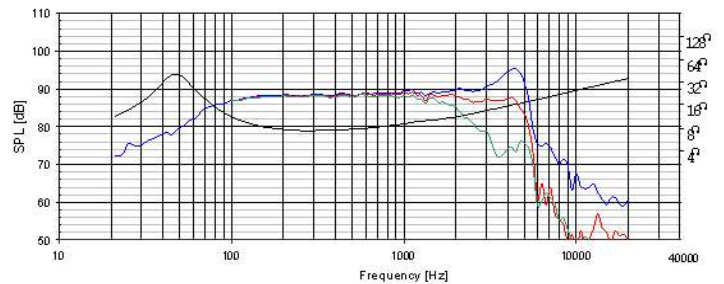

— Impedance — On-axis — 30 degrees — 60 degrees

## 830869

## 8" Nomex Woofer



- Nomex fiber cone
- Rubber surround
- Cast frame - truncated
- Ventilated raised spider
- Shorting rings
- 225mm flange
- 205mm truncated
- 190mm cut out
- 91mm depth

Znom	8	ohm	Sd	221	cm <sup>2</sup>
Re	6	ohm	BL	9.6	N/A
Le	1.8	mH	Vas	76.1	ltrs
fs	39.5	Hz	Xmax	5.5	mm peak
Qms	3.94		Voice Coil Ø	33	mm
Qes	0.31		Sensitivity		
Qts	0.29		2.83V / 1m	90.0	dB
Mms	25.9	g	Power (IEC)		W
Cms	1.13	mm/N	Magnet weight	0.68	kg

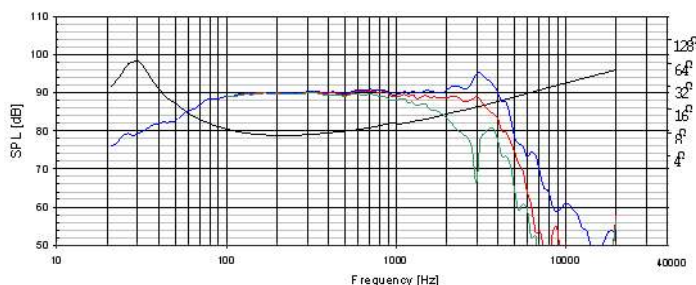

— Impedance — On-axis — 30 degrees — 60 degrees

## 830667

## 8" SLS Subwoofer



- Coated Paper cone
- Rubber surround
- Rigid stamped frame
- Ventilated raised spider
- Bumped back plate
- Shorting ring
- 213mm flange

Znom	8	ohm	Sd	204	cm <sup>2</sup>
Re	5.4	ohm	BL	8.3	N/A
Le	2.1	mH	Vas	33.1	ltrs
fs	36.5	Hz	Xmax	8.5	mm peak
Qms	7.8		Voice Coil Ø	39	mm
Qes	0.59		Sensitivity		
Qts	0.54		2.83V / 1m	87.2	dB
Mms	33.0	g	Power (IEC)	220	W
Cms	0.57	mm/N	Magnet weight	0.87	kg

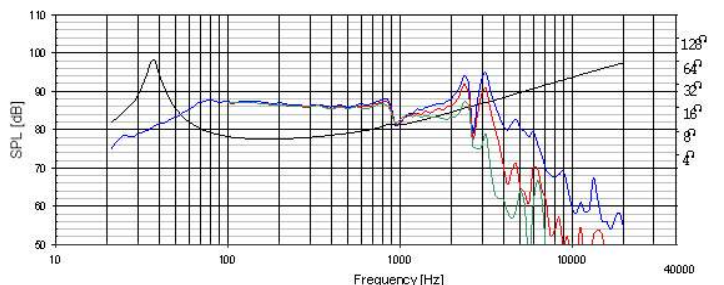

— Impedance — On-axis — 30 degrees — 60 degrees

## 830668

## 10" SLS Subwoofer



- Coated Paper cone
- Rubber surround
- Rigid stamped frame
- Ventilated raised spider
- Bumped back plate
- Shorting ring
- 263mm flange
- 226mm cut out
- 123mm depth

Znom	8	ohm	Sd	335	cm <sup>2</sup>
Re	5.6	ohm	BL	10.2	N/A
Le	3.3	mH	Vas	69.3	ltrs
fs	33.3	Hz	Xmax	8	mm peak
Qms	4.85		Voice Coil Ø	39	mm
Qes	0.57		Sensitivity		
Qts	0.51		2.83V / 1m	88.7	dB
Mms	51.1	g	Power (IEC)		W
Cms	0.45	mm/N	Magnet weight	0.87	kg

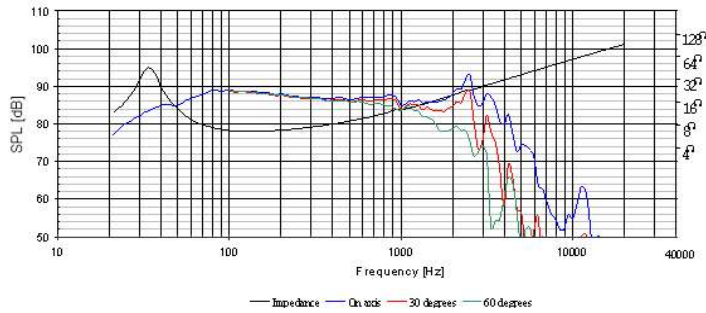

## 830669

## 12" SLS Subwoofer



- Coated Paper cone
- Rubber surround
- Rigid stamped frame
- Ventilated raised spider
- Bumped back plate
- Shorting ring
- 315mm flange
- 275mm cut out
- 140mm depth

Znom	8	ohm	Sd	540	cm <sup>2</sup>
Re	5.7	ohm	BL	12.2	N/A
Le	3.1	mH	Vas	172.4	ltrs
fs	28.0	Hz	Xmax	8	mm peak
Qms	6.70		Voice Coil Ø	39	mm
Qes	0.51		Sensitivity		
Qts	0.47		2.83V / 1m	91.2	dB
Mms	75.4	g	Power (IEC)		W
Cms	0.43	mm/N	Magnet weight	1.28	kg

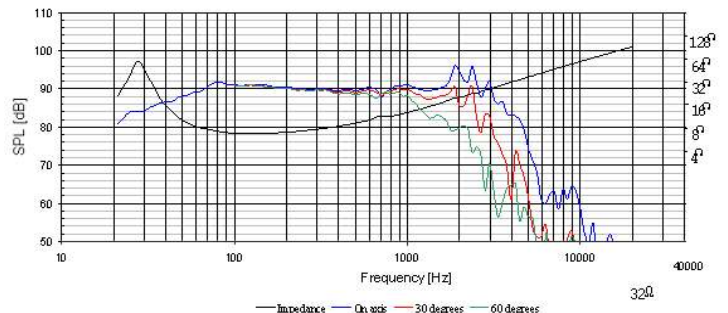

## 830867

## 15" SLS Subwoofer



- Coated Paper cone
- Rubber surround
- Rigid stamped frame
- Ventilated raised spider
- Bumped back plate
- Shorting ring
- 400mm flange

Znom	8	ohm	Sd	892	cm <sup>2</sup>
Re	5.5	ohm	BL	20.4	N/A
Le	4.1	mH	Vas	329.4	ltrs
fs	23.6	Hz	Xmax	8	mm peak
Qms	5.17		Voice Coil Ø	76	mm
Qes	0.30		Sensitivity		
Qts	0.28		2.83V / 1m	94.1	dB
Mms	152	g	Power (IEC)		W
Cms	0.30	mm/N	Magnet weight	2.24	kg

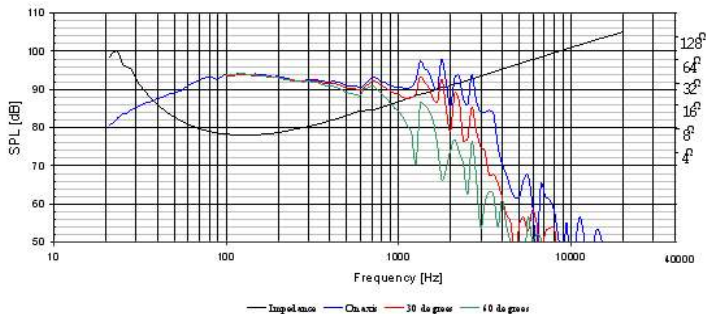

## 830452

## 10" XLS Subwoofer



- Extra Long Stroke Sub
- Thick Nomex fiber cone
- Cast frame
- Big roll rubber surround
- Works well with 830481 passive in 20 liters
- 269.3mm Ø flange
- 240mm Ø cut out
- 107mm depth

Znom	8	ohm	Sd	333	cm <sup>2</sup>
Re	3.4	ohm	BL	17.5	N/A
Le	4.3	mH	Vas	80.2	ltrs
fs	18.6	Hz	Xmax	12.5	mm peak
Qms	2.66		Voice Coil Ø	51	mm
Qes	0.18		Sensitivity		
Qts	0.17		2.83V / 1m	88.4	dB
Mms	139.3	g	Power (IEC)	200	W
Cms	0.52	mm/N	Magnet weight	2.42	kg

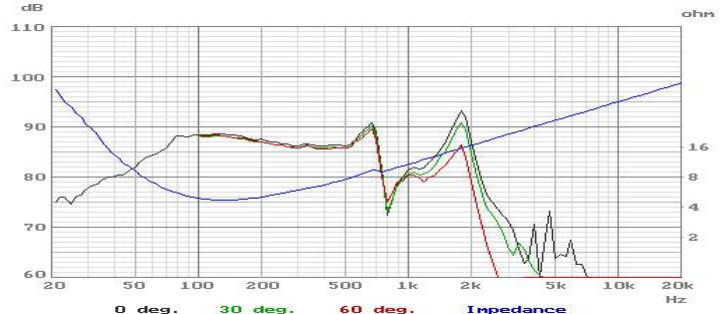

## 830481

## 10" XLS 400g Passive



- Extra Long Stroke Passive Radiator
- Thick Nomex fiber cone
- Cast frame
- Big roll rubber surround
- Threaded M5 bolt hole for adding weight
- 269.3mm Ø flange
- 240mm Ø cut out

Znom	ohm	Sd	333	cm <sup>2</sup>
Re	ohm	BL		N/A
Le	mH	Vas	80	ltrs
fs	11.2 Hz	Xmax	22	mm peak
Qms	14	Sensitivity		
Qes			2.83V / 1m	dB
Qts		Longterm Max		
Mms	400 g	System Power		W
Cms	0.508 mm/N	Magnet weight		kg

One Peerless 830452 10" XLS woofer in 1.0 cubic foot box with two Peerless 830481 10" XLS 400g passive radiators and the Madisound KG5230 amplifier with 90Hz x-over.



## 830548

## 12" XLS 425g Passive



- Extra Long Stroke Passive Radiator
- Thick Nomex fiber cone
- Cast frame
- Big roll rubber surround
- Threaded M5 bolt hole for adding weight
- 308mm Ø flange
- 278mm Ø cut out

Znom	ohm	Sd	466	cm <sup>2</sup>
Re	ohm	BL		N/A
Le	mH	Vas		ltrs
fs	10.4 Hz	Xmax	22	mm peak
Qms	15.2	Sensitivity		
Qes			2.83V / 1m	dB
Qts		Longterm Max		
Mms	425 g	System Power		W
Cms	0.55 mm/N	Magnet weight		kg

One Peerless 830500 12" XLS woofer in a 1.25 cubic foot enclosure with one Peerless 830548 passive radiator and a Madisound KG5230 amplifier with active crossover at 90Hz.

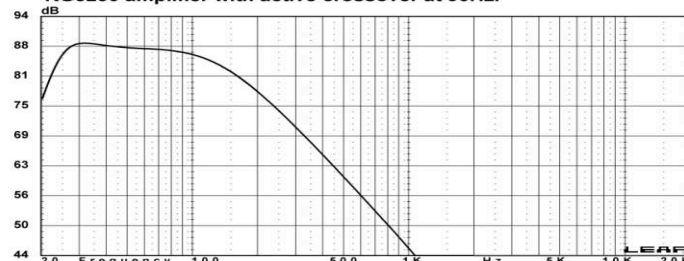

## 830500

## 12" XLS Subwoofer



- Extra Long Stroke Sub
- Thick Nomex fiber cone
- Cast frame
- Works well with 830548 passive in 40 liters
- Big roll rubber surround
- 308mm Ø flange
- 278mm Ø cut out
- 126mm depth

Znom	8	ohm	Sd	462	cm <sup>2</sup>
Re	3.5	ohm	BL	17.6	N/A
Le	4.2	mH	Vas	136.8	ltrs
fs	17.8	Hz	Xmax	12.5	mm peak
Qms	3.76		Voice Coil Ø	51	mm
Qes	0.22		Sensitivity		
Qts	0.21			2.83V / 1m	90.6 dB
Mms	172.3	g	Power (IEC)	250	W
Cms	0.46	mm/N	Magnet weight	2.42	kg

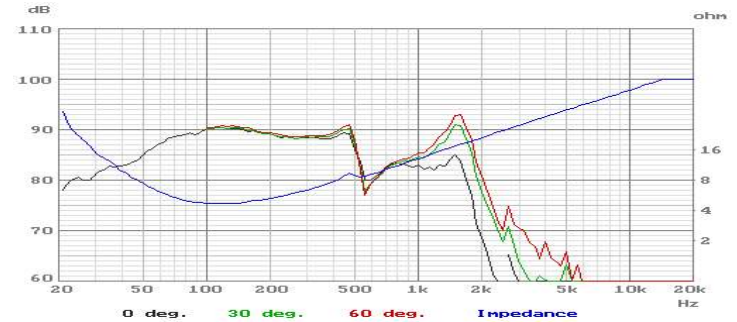

## 830846 10" XXLS DVC Subwoofer



- Extra Extra Long Stroke
- Thick Nomex fiber cone
- Cast frame
- Big roll rubber surround
- Good for 50 liter vented box, 3" port 10" long
- 269.3mm flange
- 240mm cut out
- 137mm depth

Znom	4	ohm	Sd	352	cm <sup>2</sup>
Re	2.6	ohm	BL	10.1	N/A
Le	1.6	mH	Vas	81.8	ltrs
fs	24.3	Hz	Xmax	12.5	mm peak
Qms	9.24		Voice Coil Ø	51	mm
Qes	0.34		Sensitivity		
Qts	0.33			2.83V / 1m	91 dB
Mms	89.7	g	Power (IEC)	175	W RMS
Cms	0.48	mm/N	Magnet weight	2.4	kg

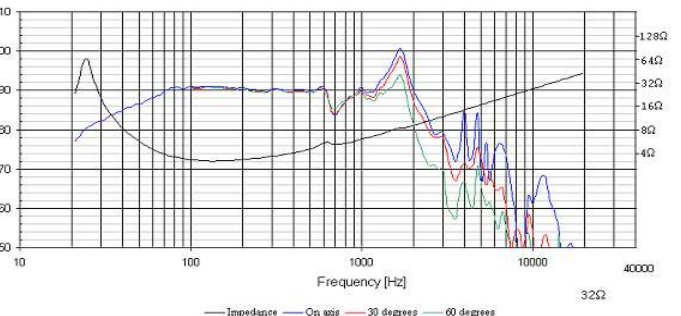



## 830843

## 10" XXLS Subwoofer



- Extra Extra Long Stroke
- Thick Nomex fiber cone
- Cast frame
- Big roll rubber surround
- Good for 62 liter sealed box (2.2cf)
- 269.3mm flange
- 240mm cut out
- 137mm depth

Znom	8	ohm	Sd	352	cm <sup>2</sup>
Re	5.8	ohm	BL	12.5	N/A
Le	2.8	mH	Vas	86.7	ltrs
fs	25.0	Hz	Xmax	12.5	mm peak
Qms	9.03		Voice Coil Ø	51	mm
Qes	0.47		Sensitivity		
Qts	0.44		2.83V / 1m	87.2	dB
Mms	79.9	g	Power (IEC)	175	W RMS
Cms	0.51	mm/N	Magnet weight	2.4	kg

## 830842

## 10" XXLS Subwoofer



- Extra Extra Long Stroke
- Thick Nomex fiber cone
- Cast frame
- Big roll rubber surround
- Good for use with 830481 Passive in 20 ltrs
- 269.3mm flange
- 240mm cut out
- 137mm depth

Znom	4	ohm	Sd	352	cm <sup>2</sup>
Re	2.6	ohm	BL	14.9	N/A
Le	4.2	mH	Vas	88.4	ltrs
fs	19.2	Hz	Xmax	12.5	mm peak
Qms	8.74		Voice Coil Ø	51	mm
Qes	0.19		Sensitivity		
Qts	0.19		2.83V / 1m	88.4	dB
Mms	133.8	g	Power (IEC)	175	W RMS
Cms	0.52	mm/N	Magnet weight	2.4	kg

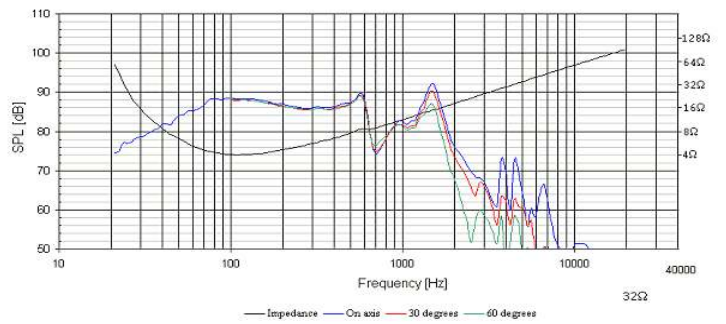
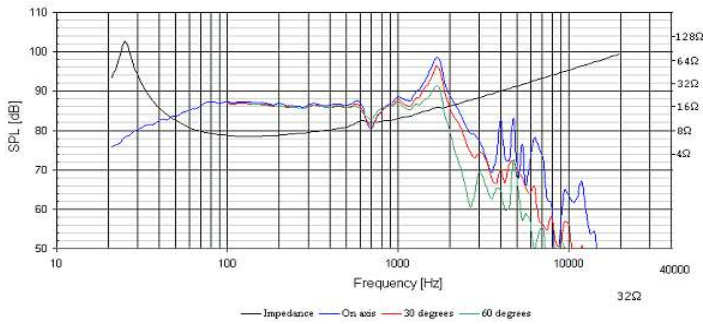

## 830847 12" XXLS DVC Subwoofer



- Extra Extra Long Stroke
- Thick Nomex fiber cone
- Cast frame
- Big roll rubber surround
- Good for 80 liter vented box. 3" vent 8.75" long
- 308mm Ø flange
- 278mm Ø cut out
- 145mm depth

Specs are with coils in parallel

Znom	4	ohm	Sd	466	cm <sup>2</sup>
Re	2.5	ohm	BL	10.2	N/A
Le	1.8	mH	Vas	144.2	ltrs
fs	21.8	Hz	Xmax	12.5	mm peak
Qms	10.24		Voice Coil Ø	51	mm
Qes	0.37		Sensitivity		
Qts	0.36		2.83V / 1m	92	dB
Mms	110.9	g	Power (IEC)	175	W RMS
Cms	0.48	mm/N	Magnet weight	2.4	kg

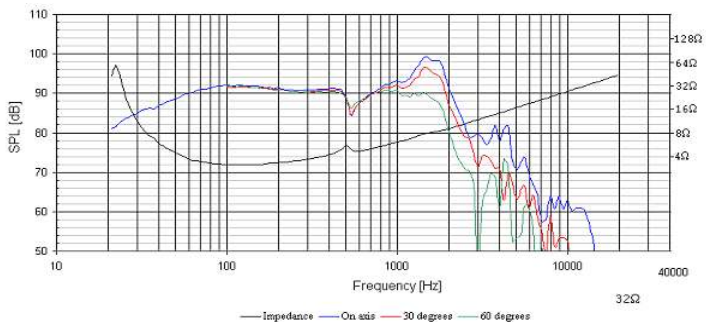

## 830845

## 12" XXLS Subwoofer



- Extra Extra Long Stroke
- Thick Nomex fiber cone
- Cast frame
- Big roll rubber surround
- Good for 62 liter sealed box (2.2cf)
- 308mm Ø flange
- 278mm Ø cut out
- 145mm depth

Znom	8	ohm	Sd	466	cm <sup>2</sup>
Re	5.9	ohm	BL	13.1	N/A
Le	3.6	mH	Vas	162.5	ltrs
fs	21.5	Hz	Xmax	12.5	mm peak
Qms	9.68		Voice Coil Ø	51	mm
Qes	0.47		Sensitivity		
Qts	0.45		2.83V / 1m	88	dB
Mms	101.4	g	Power (IEC)	175	W RMS
Cms	0.54	mm/N	Magnet weight	2.4	kg

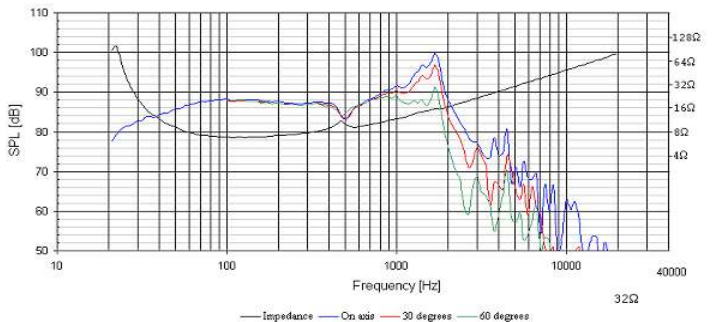

## 830844

## 12" XXLS Subwoofer



- Extra Extra Long Stroke
- Thick Nomex fiber cone
- Cast frame
- Big roll rubber surround
- Good for use with 840548 passive in 33 ltrs
- 308mm Ø flange
- 278mm Ø cut out
- 145mm depth

Znom	4	ohm	Sd	466	cm <sup>2</sup>
Re	2.8	ohm	BL	15.7	N/A
Le	4.2	mH	Vas	156.5	ltrs
fs	17.7	Hz	Xmax	12.5	mm peak
Qms	8.21		Voice Coil Ø	51	mm
Qes	0.20		Sensitivity		
Qts	0.20		2.83V / 1m	90.3	dB
Mms	155.9	g	Power (IEC)	175	W RMS
Cms	0.52	mm/N	Magnet weight	2.4	kg

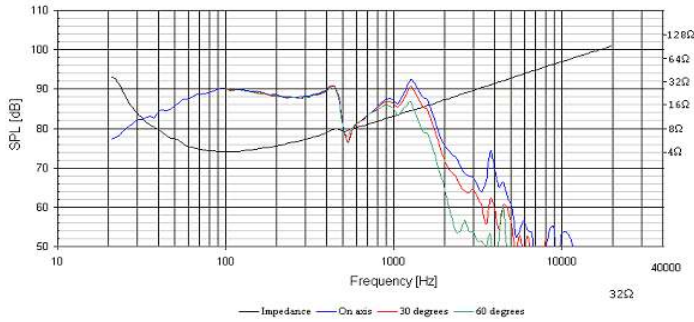

## 830516

## 4" CD Car Woofer



- Poly cone
- Rubber surround
- Peerless Logo
- Four removable mounting tabs
- Extended response
- Response to 9kHz
- 100.5mm flange
- 56.5mm depth

Znom	4	ohm	Sd	58	cm <sup>2</sup>
Re	3.4	ohm	BL	4.0	N/A
Le	0.5	mH	Vas	3.3	ltrs
fs	78.9	Hz	Xmax	0.5	mm peak
Qms	3.65		Voice Coil Ø	26	mm
Qes	0.59		Sensitivity		
Qts	0.51		2.83V / 1m	89.4	dB
Mms	5.8	g	Power (IEC)	100	W
Cms	0.70	mm/N	Magnet weight	0.23	kg

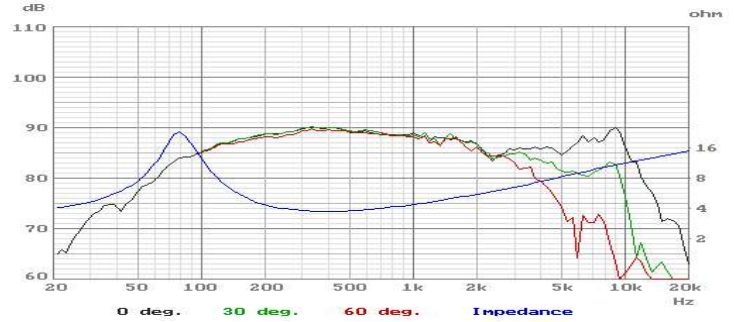

## 830512

## 5.25" CD Car Woofer



- Poly cone
- Rubber surround
- Peerless logo
- Removable mounting tabs
- Smooth response curve
- 130mm flange
- 117mm cut out
- 60mm depth

Znom	4	ohm	Sd	91	cm <sup>2</sup>
Re	3.3	ohm	BL	4.8	N/A
Le	0.6	mH	Vas	6.6	ltrs
fs	66.2	Hz	Xmax	2	mm peak
Qms	3.55		Voice Coil Ø	26	mm
Qes	0.60		Sensitivity		
Qts	0.51		2.83V / 1m	90.1	dB
Mms	10	g	Power (IEC)	110	W
Cms	0.58	mm/N	Magnet weight	0.32	kg

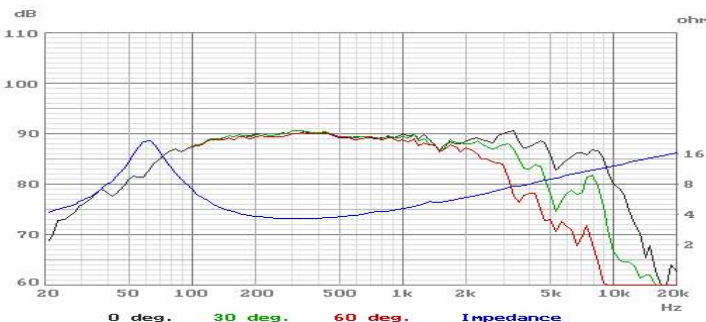

## 830513

## 6.5" CD Car Woofer



- Poly cone
- Rubber surround
- Peerless logo
- 6.5" frame size
- Use in door or 0.4cf sealed box
- 165mm flange
- 143.5mm cut out
- 79mm depth

Znom	4	ohm	Sd	143	cm <sup>2</sup>
Re	3.3	ohm	BL	5.6	N/A
Le	0.5	mH	Vas	17.7	ltrs
fs	48.7	Hz	Xmax	2	mm peak
Qms	2.51		Voice Coil Ø	26	mm
Qes	0.54		Sensitivity		
Qts	0.45		2.83V / 1m	91	dB
Mms	16.9	g	Power (IEC)	140	W
Cms	0.63	mm/N	Magnet weight	0.40	kg

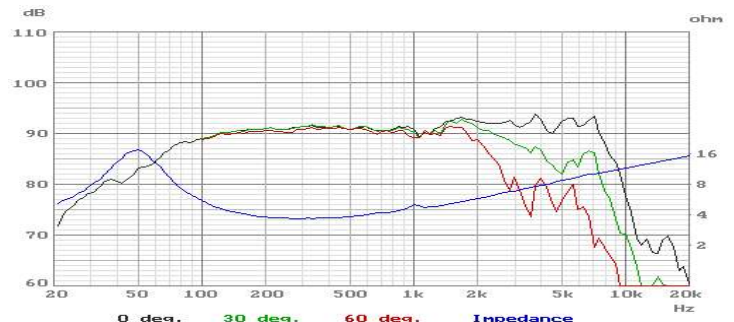



## 830876 10" XXLS Car Subwoofer



- Extra Extra Long Stroke
- Nomex fiber cone
- Decorative logo and magnet cover
- Big roll rubber surround
- Use sealed or vented
- 269.3mm Ø flange
- 240mm Ø cut out

Znom	4	ohm	Sd	333	cm <sup>2</sup>
Re	1.7	ohm	BL	10.4	N/A
Le	1.5	mH	Vas	23.6	ltrs
fs	39.0	Hz	Xmax	12.5	mm peak
Qms	6.79		Voice Coil Ø	51	mm
Qes	0.47		Sensitivity	2.83V / 1m	92.2 dB
Qts	0.44		Power (IEC)	200	W
Mms	121.1	g	Magnet weight	2.4	kg
Cms	0.14	mm/N			

## 830877 12" XXLS Car Subwoofer



- Extra Long Stroke Sub
- Nomex fiber cone
- Decorative logo and magnet cover
- Big roll rubber surround
- 51mm Ø voice coil
- 308mm Ø flange
- 278mm Ø cut out

Znom	4	ohm	Sd	466	cm <sup>2</sup>
Re	1.7	ohm	BL	10.6	N/A
Le	1.3	mH	Vas	39.9	ltrs
fs	35.0	Hz	Xmax	12.5	mm peak
Qms	7.31		Voice Coil Ø	51	mm
Qes	0.52		Sensitivity	2.83V / 1m	94.3 dB
Qts	0.49		Power (IEC)	250	W
Mms	156.1	g	Magnet weight	2.4	kg
Cms	0.13	mm/N			

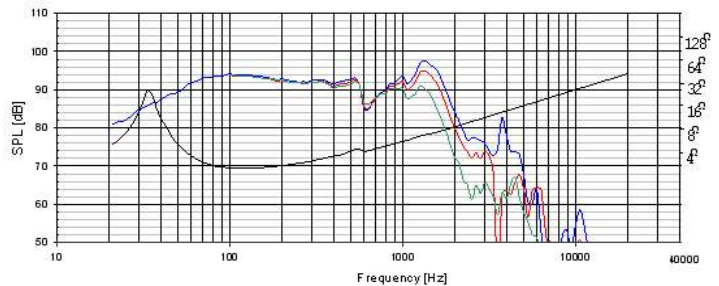
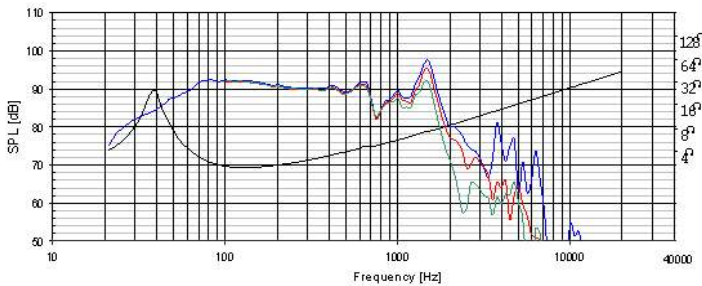

### Definition 5 System Autosound 5" 2-Way Cat# 822000



- Fibrous pulp cone with AG Resin
- Butyl rubber surround
- Non-resonant Glass resin basket
- Black anodized aluminum VC former
- 1" ferro-fluid cooled dome tweeter
- Tweeter flush mount & angle mount kits
- Premium component crossovers
- 3 position tweeter level control
- Gold plated terminals & connectors
- Grills, wire, hardware, templates



Acoustical 24dB per octave crossover with premium components. Film capacitor on tweeter and heavy gauge air core inductors.

### Definition 6 System Autosound 6" 2-Way Cat# 822001



Definition 5 Woofer



Definition 6 Woofer

**Definition Series ...**

**Component Autosound Systems**



**PHY TW37 \$558 /Pair** • Piezo Electric 37mm Paper Cone Tweeter



- Brass frame
- Internal Crossover
- 98dB
- Frequency response 10kHz-30kHz
- Sold in Matched Pairs

Znom	70	ohm
Sensitivity	98	dB
Ms	0.07	g
Weight	0.42	kg
Diameter	83	mm
Cut out	51	mm
Depth	83	mm



**PHY H21LB15 \$665** • 8" Wide Range



- Paper cone
- Alnico 3SC magnet
- Cast Brass frame
- Shielded magnet
- Designed for use in an open baffle (no-enclosure). Plans are available at: [www.tonianlabs.com](http://www.tonianlabs.com)

Znom	15	ohm	VC Ø	25	mm
fs	45	Hz	Sensitivity	98	dB
Nom. Power	25	W	Zmin	14.4	ohm
Re	12.8	ohm	Zmax	155	ohm
Qms	6.10		Frame diameter	234	mm
Qes	0.65		Cut out diameter	202	mm
Qts	0.59		Depth	154	mm
Mms	9.4	g			
Vas	97	ltrs			

**With Silver VC wire \$828.30**

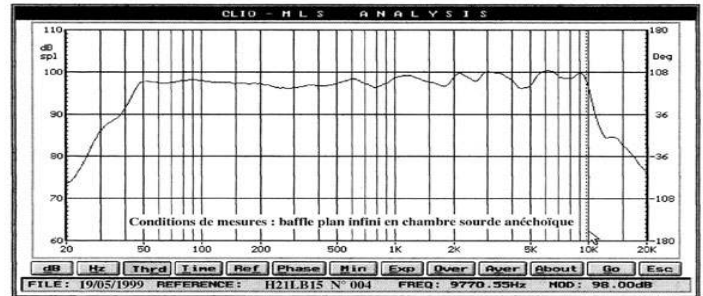
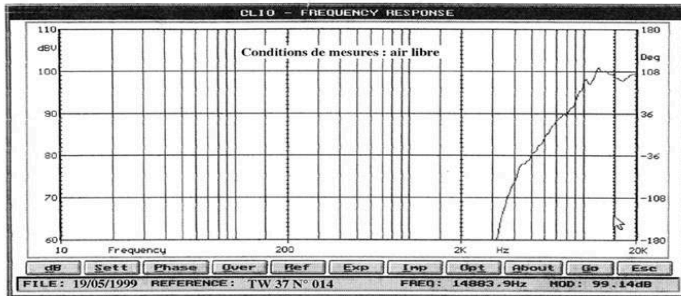

**PHY H30LB15 \$1038** • 12" Wide Range



- Paper cone
- Alnico 3SC magnet
- Cast Brass frame
- Shielded magnet
- Designed for use in an open baffle (no-enclosure). Plans are available at: [www.tonianlabs.com](http://www.tonianlabs.com)

Znom	16	ohm	VC Ø	35	mm
fs	36	Hz	Sensitivity	97	dB
Nom. Power	50	W	Zmin	14.9	ohm
Re	13.8	ohm	Zmax	125	ohm
Qms	6.60		Frame diameter	311	mm
Qes	0.62		Cut out diameter	270	mm
Qts	0.59		Depth	195	mm
Mms	23.1	g			
Vas	224	ltrs			

**With Silver VC wire \$1208.90**

**PHY KM30 \$1203** • 12" Coaxial Speaker



- Paper cone woofer
- Piezo Paper cone tweeter
- Cast Brass frame
- Shielded magnet
- Designed for use in an open baffle (no-enclosure). Plans are available at: [www.tonianlabs.com](http://www.tonianlabs.com)

Znom	16	ohm	VC Ø	35	mm
fs	36	Hz	Sensitivity	97	dB
Nom. Power	50	W	Zmin	14.9	ohm
Re	13.8	ohm	Zmax	125	ohm
Qms	6.60		Frame diameter	311	mm
Qes	0.62		Cut out diameter	270	mm
Qts	0.59		Depth	195	mm
Mms	23.2	g			
Vas	224	ltrs			

**With Silver VC wire \$1373.70**

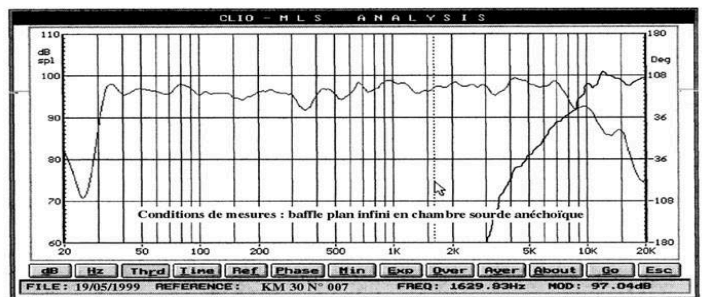
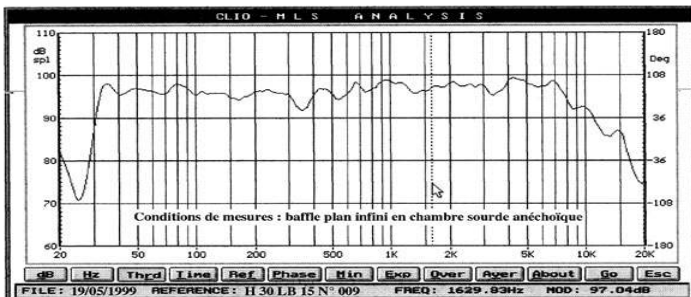



All Kapton Voice Coil Formers are now Fiberglass. Dupont no longer sells Kapton to the Loudspeaker Industry.

Model	Imp Ω	Fs Hz	Qts	Vas Ltrs	Power @12dB	dB 283V/m	Xmax mm P	Box Liter Sealed/Vented	F3 Hz	Price Each
<b>Revelator Series Tweeters</b>										
R2904/7000-00: Premium Ring Radiator - Silver	4	520			160@2.5k	94.5	0.2			\$398.00
R2904/7000-05: Premium Ring Radiator - Black w/silver plug	4	520			160@2.5k	94.5	0.2			\$398.00
R2904/7000-09: Premium Ring Radiator - Black	4	520			160@2.5k	94.5	0.2			\$398.00
D2904/7100-00: Premium Wide Surround Tweeter - Silver	4	520			160@2.5k	94.5	0.2			\$267.00
D2904/7100-01: Premium Wide Surround Tweeter - Black	4	520			160@2.5k	94.5	0.2			\$267.00
D2905/9900: 1" textile dome, SD-2, LCD, NRC, CDD	8	500			225@2.8k	91	0.4			\$201.50
D2904/9800: 1" aluminum dome, diffuser, SD-2, NRC	4	500			160@2.8k	90	0.1			\$156.00
D2905/9700: 1" textile dome, SD-2, LCD, NRC	8	500			225@2.8k	89.5	0.4			\$142.85
D2904/9400SE: 1" textile dome, ferro fluid, heavy duty terminals	4	650			150@2.5k	91	0.1			\$145.90
D2904/6000-00: 1" dome, neodymium magnet, grill - 60mm flange	4	750			150@2.7k	90	0.25			\$169.65
D2904/6000-01: 1" dome, neodymium magnet - 60mm flange	4	750			150@2.7k	90.5	0.25			\$164.55
D3004/6600-00: 1" dome, AirCirc, neodymium magnet	4	520			160@2.5k	92.5	0.2			\$220.00
<b>Revelator Series Midranges</b>										
12M/4631G: 4.5" slit paper cone, neodymium magnet, R3	4	75	0.33	2.4	40@75	89	3.0	0.7 / 1.0	160 / 100	\$218.55
15M/4531K: 5" slit paper cone midrange, Glass former	4	35	0.22	24		90	3.0	3.0 / 5.0	100 / 70	\$205.75
<b>Revelator Series Mid/Bass &amp; Woofers</b>										
15S/8530K-01: Shielded 5" paper cone, NRCS, SD-1, R3	8	30	0.35	28	60	84.5	6.5	9.5 / 15	60 / 40	\$216.30
15W/4531G: 5" slit paper cone, NRCS, SD-1, R3, Glass former	4	39.5	0.32	16	60	87	6.5	4 / 6	88 / 58	\$204.25
15W/8530K-00: 5" paper cone, NRCS, SD-1, R3, Glass former	8	30	0.27	28	60	85.5	6.5	5.1 / 7.4	77 / 55	\$207.90
15W/8531K-00: Same as 15W/8530K-01, but with non-coated mat appearance										\$204.15
15W/8530K-01: 5" paper cone, NRCS, SD-1, R3, Glass former	8	30	0.35	28	60	84.5	6.5	9.5 / 15	60 / 40	\$202.80
18S/8531G: Shielded, 7" slit paper cone, SD-1, R3, Glass form	8	28	0.40	59	60	86.5	6.5	29 / 42	48 / 33	\$228.00
18W/4531G: 7" slit paper cone, SD-1, R3, Glass former	4	33	0.35	42	70	90	6.5	14 / 23	65 / 41	\$205.00
18W/8531G: 7" slit paper cone, SD-1, R3, Glass former	8	28	0.36	59	60	87	6.5	21 / 36	54 / 35	\$205.00
18W/16531G: 7" slit paper cone, SD-1, RS, Glass former	16	27	0.39	61.5	60	83	6.5	26 / 40	50 / 32	\$214.60
22W/8851T: 8" hard paper cone, SD-1, Titanium former	8	21	0.25	127	170	88	9.0	18 / 34	60 / 38	\$263.60
26W/8861T: 10" hard paper cone, SD-1, Titanium former	8	19	0.31	234	170	88.5	9.0	55 / 90	40 / 28	\$285.00
26W/4867T: 10" Black Aluminum cone, SD-1, Titanium former	4	18	0.30	223	170	89	9.0	46 / 71	43 / 29	\$258.50
26W/8867T: 10" Black Aluminum cone, SD-1, Titanium former	8	19	0.29	179	170	87	9.0	36 / 57	46 / 31	\$258.50
23W/4557T: 10" Aluminum Cone, SD-1, Titanium former	4	20.5	0.44	43.5	225	83	13	28 / 59	33 / 27	\$297.50
23W/0-00: 10" Aluminum Cone Passive Radiator										\$128.80
<b>Classic Series Tweeters and Mid/Tweeter</b>										
D2008/8512: ¾" dome, chamber, ff	8	800			150@4k	90	0.7			\$64.50
D2010/8513: ¾" dome, chamber, foam on faceplate, ff	8	800			150@4k	90	0.7			\$66.60
D2905/9300: 1" textile dome, chamber, FF	8	650			150@2.5k	90	0.4			\$109.55
D2905/9500: 1" textile dome, NRC, FF	8	550			150@2.5k	90	0.4			\$121.75
D3806/8200: 1.5" textile dome, mid-tweeter, SD	8	450			100@1k	90	0.4			\$146.80
<b>Classic Series Midranges</b>										
13M/8636: 5" Kevlar cone, SD, R	8	77	0.32	3.0	100@300	86.5	1.5	0.8 / 1.2	170 / 125	\$175.70
13M/8640: 5" paper cone, SD, R2	8	64	0.24	2.7	100@300	87.5	1.5	0.7 / 1.0	185 / 140	\$168.55
<b>Classic Series Woofers</b>										
18S/8535: Shielded 7" carbon paper cone, SD-1, R3	8	26	0.40	72	70	86.5	5.0	33 / 49	45 / 30	\$188.20
18W/8535: 7" carbon paper cone, SD-1, R3	8	26	0.38	72	70	86.5	5.0	30 / 46	48 / 33	\$160.45
18W/8542: 7" paper cone, SD, foam surround	8	30	0.22	49	70	89	6.5	6 / 9	94 / 63	\$127.20
18W/8543: 7" polypropylene cone, SD, R	8	30	0.22	49	70	88.5	6.5	5 / 9	97 / 65	\$160.45
18W/8545: 7" carbon paper cone, SD-1, R3	8	28	0.27	48	100	88	6.5	8 / 15	75 / 46	\$147.05
18W/8545K: 7" carbon paper cone, SD-1, R3, Glass former	8	28	0.28	48	100	87.5	6.5	9 / 19	70 / 42	\$152.50
18W/8546: 7" Kevlar cone, SD-1, R3	8	22	0.19	84	100	88	6.5	7 / 11	80 / 56	\$153.40
21W/8554: 8" Kevlar cone, SD, Foam surround	8	23	0.22	160	110	90	6.5	17 / 26	75 / 50	\$182.20
21W/8555-00: 8" hard paper cone, SD-1, R3	8	20	0.31	136	100	87	6.5	35 / 48	46 / 32	\$194.70
21W/8555-01: 8" hard paper cone, SD-1, R3	8	19	0.26	136	100	87.5	6.5	21 / 30	52 / 37	\$194.70
25W/8565-01: 10" hard paper cone, SD-1, R3	8	19	0.34	229	100	88	6.5	50 / 90	40 / 28	\$209.55

Replacement voice coils and reconing are available for many Scan-speak products. Replacements for products that can't be repaired may be available at a discount.

# SCANSPEAK The Solist SCANSPEAK

Madisound is pleased to offer **Solist**, a very precise MTM speaker system. We are confident that we have achieved a speaker that meets or exceeds the expectations of today's discerning Audiophile.

The **Solist** is capable of delivering the most demanding passage without losing the delicacy of every nuance. The **Solist** has an immediacy about it that elicits excitement in the listener, yet is never fatiguing. We have listened to the **Solist** on both transistorized amplifiers and tube amplifiers and found both to be pleasing.

The **Solist** is designed around the popular **Scan-speak 18W/8545K** carbon/paper cone 7" woofer. This **18W/8545K** features a heavily damped and carbon fibre impregnated paper cone that dampens resonances normally associated with stiff cones. The magnet system is the new SD-1 system which eliminates modulation and dynamic distortion, as well as lowering clipping distortion created as the voice coil exceeds its maximum linear excursion. This woofer uses the new Fiber Glass non-conducting high temperature voice coil former, which improves bass response and resolution in the midrange frequencies. A new type of rubber surround combines dynamic linearity with low coloration.

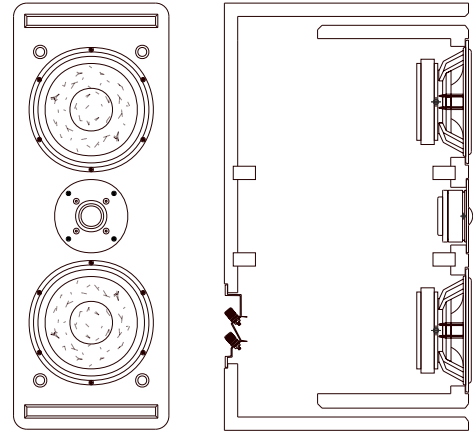

Width 8 3/4" Height 24" Depth 13 1/2"

The **Solist** high frequencies are reproduced by the **D2905/9700** tweeter. The **D2905/9700** tweeter which uses the same motor as the Revelator tweeter, but with the standard flange. The Revelator motor is state of the art, using SD caps and shorting rings that minimize electrical phase shift. The top plate has been carefully machined to reduce air noises and compression from behind the dome and to assist in cooling the voice coil. The hand coated textile dome is a refinement of earlier versions and also incorporates a special devise behind the dome to minimize dynamic compression. The 28mm voice coil uses plastic coated aluminum wire on an aluminum voice coil former. No ferrofluid is used in the air gap.



The **crossover** network was designed using our anechoic chamber, Audio Precision and the Linearx Leap software. The acoustical 18dB bi-wire network yields a seamless response from 40Hz to 20KHz. This **Premium** crossover uses some 14 awg Goertz Copper Foil inductors, Solen Polypropylene capacitors, Hovland Musicaps and Eagle resistors.

The **cabinets** are fully assembled oak veneered MDF with solid rounded oak corners in clear coat or black painted finish. The front and back are black and the front is covered by a full black grill. You can further upgrade the cabinet by installing the Deflex damping pads to reduce cabinet resonances and cut down on internal reflections.

The **cabinets** are fully assembled oak veneered MDF with solid rounded oak corners in clear coat or black painted finish. The front and back are black and the front is covered by a full black grill. You can further upgrade the cabinet by installing the Deflex damping pads to reduce cabinet resonances and cut down on internal reflections.

**Kit Price per pair \$1360.00**  
(Price per pair without cabinets \$1005.00)

**Deflex Panel Upgrade: 10 panels and glue: Add \$103.86**

**Supra Classic wiring is supplied for internal wiring.**

## SCANSPEAK

### D3004/6600-00 AirCirc 4Ω

The new D3004/660000 builds on the experience of the one-inch R29 ring radiator, resulting in low resonance frequency, but further provides the extended dispersion characteristics of a 3/4-inch dome. Tymphany's unique AirCirc Magnet System — named for the way it optimizes air flow within the chamber — rearranges the traditional magnet structure from a single magnet to an open magnetic circuit comprised of six separate neodymium slugs. This, in combination with the chamber, results in the elimination of the reflections and resonances that compromise the performance of traditional motors.



TECHNICAL DATA:				
Sensitivity	2.83V/1M	92.5dB	Lin. & max. excursion	±0.2 / ±1.6 mm
Free air resonance F <sub>s</sub>	520 Hz		Air gap flux density	-
DC resistance	3.0 ohm		Force factor BL Product	2.5 Tm
V.C. inductance	0.03 mH		Moving mass incl. air	0.35 g
Power 12dB@1Hz	160W@2.5K		Outside diameter	104 mm
Effective cone area	7 cm <sup>2</sup>		Cutout diameter	77 mm
V.C. diameter	26 mm		Flange thickness	5 mm
V.C. height	2.1 mm		Depth	23 mm
Air gap height	2.5 mm		Screw Circle	90 mm

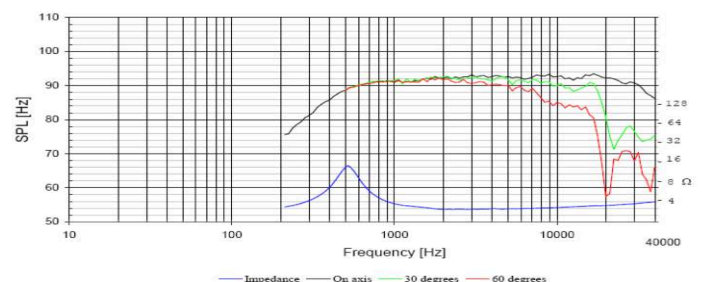





## R2904/7000-00 4Ω

The R2904/7000 tweeter is the new flagship tweeter in the Scan-speak line. This tweeter incorporates many innovative design concepts.

The first notable difference is the use of a phase plug. The dome is attached to the phase plug, so the radiating area is now concentrated around the voice coil. This offers more control and reduces distortion and loss that occur at the center of the dome on dome tweeters. The phase plug also acts as a wave guide, reducing high frequency cancellations. A specially designed venting system uses a needle to cut down on turbulence in the air cavity. Better dynamics are achieved by not using ferrofluid, voice coil cooling is performed by the venting system and conduction through copper rings. The new SD-2 neodymium magnet system improves transient response.



<b>TECHNICAL DATA:</b>		Effective cone area	5.6 cm <sup>2</sup>
Sensitivity 2.83V/1M	94.5dB	V.C. diameter	28 mm
Free air resonance Fs	520 Hz	Lin. & max. excursion	±0.2 / ±1.6mm
DC resistance	3.0 ohm	Force factor BL Product	2.8 Tm
V.C. inductance	0.01 mH	Moving mass incl. air	0.3 g
Power 12dB@Hz	150W@2.7K	Net weight	0.42 kg

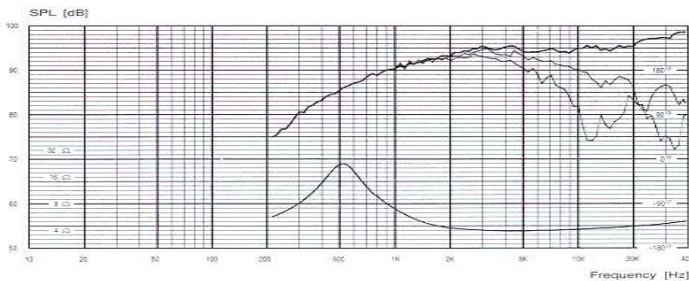

## D2904/7100-00 4Ω

The D2904/7100 tweeter is a 1" soft dome with wide surround, using the same chambering as the Ring Radiator.

The carefully designed dome and surround result in a linear response and an exceptionally good off axis response. Note the smooth roll off on the low end, making this tweeter a good choice for simple slopes.

A specially designed venting system uses a needle to cut down on turbulence in the air cavity. Better dynamics are achieved by not using ferrofluid, voice coil cooling is performed by the venting system and conduction through copper rings. The new SD-2 neodymium magnet system improves transient response.



<b>TECHNICAL DATA:</b>		Effective cone area	7 cm <sup>2</sup>
Sensitivity 2.83V/1M	94.5dB	V.C. diameter	28 mm
Free air resonance Fs	520 Hz	Lin. & max. excursion	±0.2 / ±1.6mm
DC resistance	3.0 ohm	Force factor BL Product	2.8 Tm
V.C. inductance	0.01 mH	Moving mass incl. air	0.35 g
Power 12dB@Hz	160W@2.5K	Net weight	0.42 kg

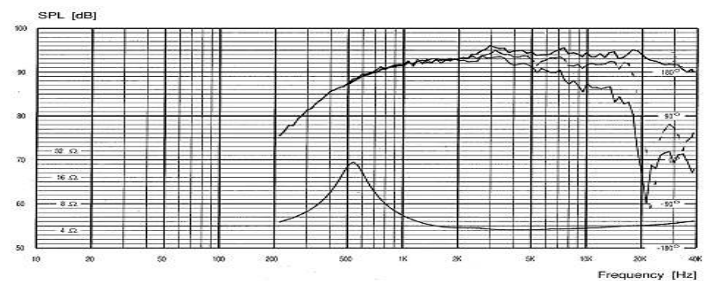

## D2905/9900 Revelator Dome Tweeter

The D2905/9900 is our state of the art tweeter. This "revelation" is a 1" textile dome tweeter that will reach new borders within high-end loudspeaker drive units. The new magnet system with SD caps and rings that eliminate the electrical phase shift. The new chamber design reduces air noises and compression. The 130mm machined aluminum front plate has more controlled directivity (down to 2KHz). The textile dome is hand coated and a special device is placed behind it to reduce dynamic compression.



<b>TECHNICAL DATA:</b>		V.C. height	-
Sensitivity 2.83V/1M	91dB	Air gap height	-
Free air resonance Fs	500 Hz	Lin. & max. excursion	±0.4 / ±1.5 mm
DC resistance	4.7 Ω	Air gap flux density	-
V.C. inductance	0.01 mH	BL	3.5 Tm
Power	225W@2.8kHz	Moving mass incl. air	0.45 g
Effective cone area	8.5 cm <sup>2</sup>	Net weight	0.8 kg
V.C. diameter	28 mm		

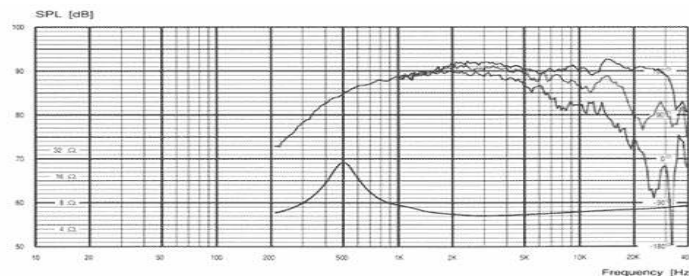

## D2904/9800 4Ω

The D2904/9800 is a high-end 1" aluminum dome tweeter. The magnet system uses the Symmetric Drive technology that almost eliminates electrical phase shift. The specially designed chamber reduces air noise and compression. The geometry of the dome causes the "break-up" to appear beyond the audible range. A specially designed diffuser is used to equalize the response in the upper octave. The tweeter has a very clear and open sound.



<b>TECHNICAL DATA:</b>		Lin. & max. excursion	±0.1 / ±1.5 mm
Sensitivity 2.83V/1M	90dB	Air gap flux density	-
Free air resonance Fs	500 Hz	Force factor BL Product	2.8 Tm
DC resistance	3.5 ohm	Moving mass incl. air	0.50 g
V.C. inductance	0.01 mH	Net weight	0.7 kg
Power 12dB@Hz	160W@2.8K	Vas	-
Effective cone area	8.5 cm <sup>2</sup>	Qms	-
V.C. diameter	28 mm	Qes	-
V.C. height	-	Qts	-
Air gap height	-		

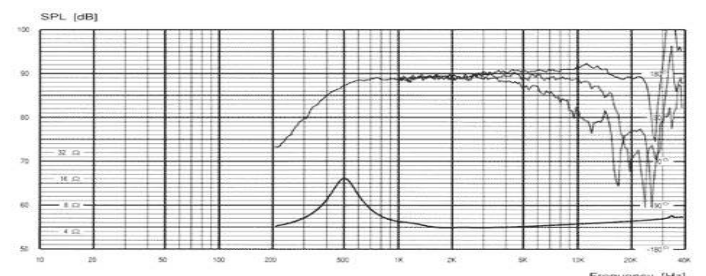

## D2905/9700 1" Dome Tweeter

The D2905/9700 uses the same hand coated dome and voice coil of the D2905/9500, but uses the motor system of the Revelator. The Symmetric Drive technology eliminates almost all electrical phase shift. The carefully machined top plate minimize air noise and compression. Copper caps act as heat conductors. High power handling is achieved without ferrofluid and improves micro-dynamic linearity. The tweeter has excellent dynamic and detailing capability.



TECHNICAL DATA:			
Sensitivity 2.83V/1M	89.5dB	Lin. & max. excursion	±0.4/ ±1.5 mm
Free air resonance Fs	500 Hz	Air gap flux density	-
DC resistance	4.7 Ω	BL	3.5 Tm
V.C. inductance	0.01 mH	Moving mass incl. air	0.45 g
Power	225W@2.8kHz	Net weight	0.7 kg
Effective cone area	8.5 cm <sup>2</sup>	Vas	-
V.C. diameter	28 mm	Qms	-
V.C. height	-	Qes	-
Air gap height	-	Qts	-

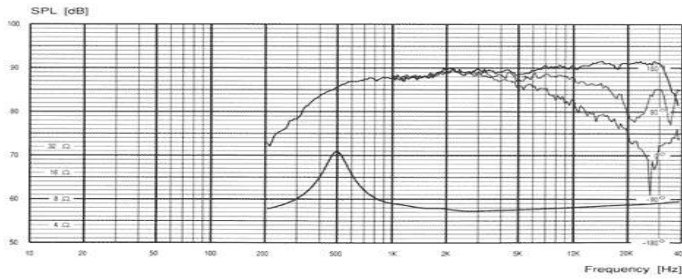

## D2904/9400SE 1" Dome Tweeter

The D2904/9400SE Special Edition tweeter features a 1" coated textile dome. The metal flange suppresses resonances in the face plate. The nominal impedance is 4 ohm, for increased sensitivity. The voice coil is ferrofluid cooled, for increased power handling and easier crossover design. The tweeter has a very smooth response and a very smooth roll off on the upper and lower frequencies. The off axis response is also respectable.



This tweeter would also be useful in autosound applications.

TECHNICAL DATA:			
Sensitivity 2.83V/1M	91dB	Power	150W@2.5kHz
Free air resonance Fs	650 Hz	Effective cone area	8.5 cm <sup>2</sup>
Nominal Impedance	4 Ω	V.C. diameter	28 mm
DC resistance	3.5 Ω	Lin. & max. excursion	±0.1/ ±1.5 mm
V.C. inductance	0.08 mH	BL	3.0 Tm
		Moving mass incl. air	0.40 g

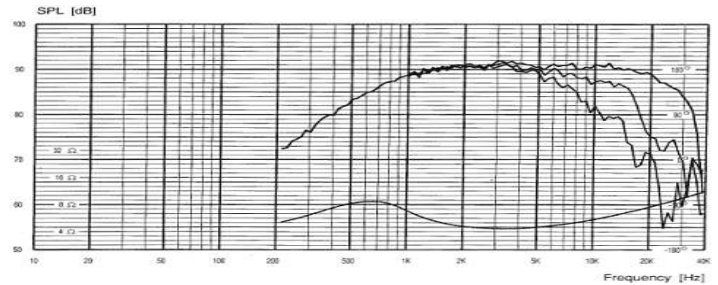

## D2904/6000-01 4Ω

The D2904/6000-01 tweeter has a 1" coated textile dome and a neodymium magnet system. This speaker uses a compact self shielding Symmetric Drive magnet system, utilizing three powerful neodymium magnets. The cavity under the voice coil is coupled to the chamber through eight holes in the top plate. Pure cotton is used as damping material. The textile diaphragm is carefully hand coated. The reproduction is very dynamic and open, with low levels of compression. Perfect for A/V. Also available with grill as D2904/6000-00.



TECHNICAL DATA:			
Sensitivity 2.83V/1M	90.5dB	Effective cone area	8 cm <sup>2</sup>
Free air resonance Fs	750 Hz	V.C. diameter	28 mm
DC resistance	3.5 ohm	Lin. & max. excursion	±0.25 / ±1.3mm
V.C. inductance	0.02 mH	Force factor BL Product	2.7 Tm
Power 12dB@Hz	150W@2.7K	Moving mass incl. air	0.4 g
		Net weight	0.13 kg

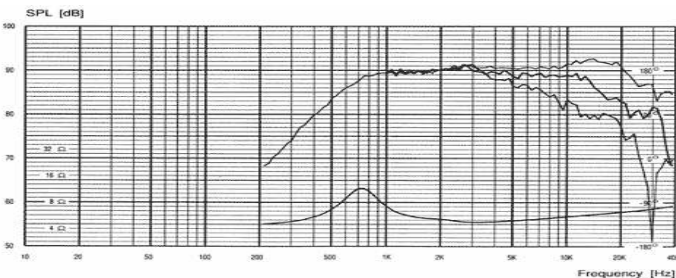

## 12M/4631G 4Ω Revelator 4.5" Midrange

The 12M/4631G is a Revelator driver using the "slit cone" technology. Some of the slits are used to control cone resonance and the other set of slits add rigidity. This speaker also has the new dynamic linear suspension for lower compression and higher linearity. Every facet of this driver is designed to reduce resonance in all structures. A neodymium magnet has been chosen to reduce the depth, yet increase the magnetic energy. The short field length of a neodymium magnet also allows this driver to be used for A/V.



TECHNICAL DATA:			
Sensitivity 2.83V/1M	89dB	V.C. height	-
Free air resonance Fs	75 Hz	Air gap height	-
DC resistance	3.2 Ω	Lin. & max. excursion	±3/ ±7 mm
V.C. inductance	0.22 mH	Air gap flux density	-
Power	40W	BL	5.3 Tm
Effective cone area	49 cm <sup>2</sup>	Moving mass incl. air	6.5 g
V.C. diameter	38 mm	Net weight	0.51 kg

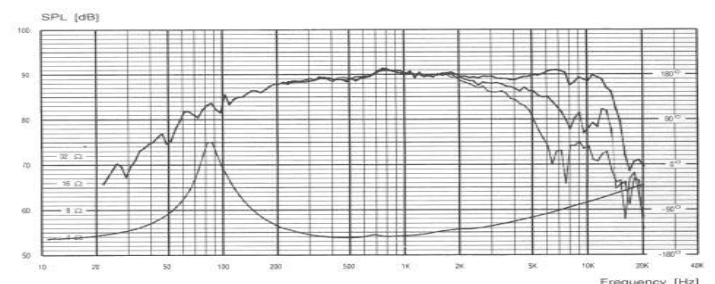





## 15M/4531K-00 4Ω

The 15M/4531K-01 is a 5 1/2" Revelator midrange. It features a slit-paper non-resonant cone and dust cap structure, dynamic linear suspension, SD-1 magnet system, "Grasshopper" cast chassis with maximized air flow, glass fiber voice coil former and resonance terminating mounting system. The 15M/4531K is intended for use as a midrange, with a usable frequency range between 100Hz and 6kHz. As you can see from the response curve, this speaker has a lot of energy in the upper frequency range.



### TECHNICAL DATA:

Sensitivity 2.83V/1M	90 dB	Lin. & max. excursion	±3 & ±8mm
Free air resonance Fs	35 Hz	Air gap flux density	-
DC resistance	3.5 ohm	Force factor BL Product	6.0 Tm
V.C. inductance	0.17 mH	Moving mass incl. air	11 g
Power 12dB@Hz	60W	Net weight	1.6 kg
Effective cone area	95 cm <sup>2</sup>	Vas	24 ltrs
V.C. diameter	38 mm	Qms	4.8
V.C. height	-	Qes	0.24
Air gap height	-	Qts	0.22

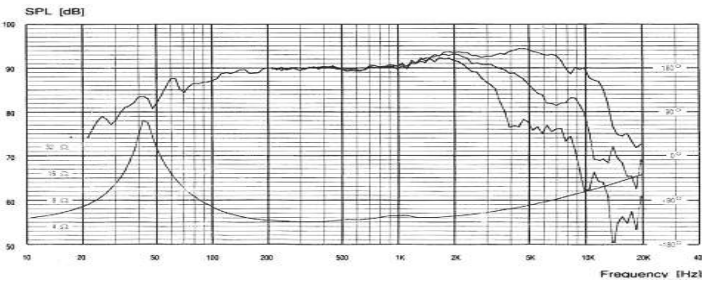

## 15S/8530K-01 - Magnetically Shielded

The 15S/8530K-01 is a 5 1/2" Revelator mid/woofer. It features a non-resonant cone and dust cap structure, dynamic linear suspension, SD-1 magnet system, "Grasshopper" cast chassis with maximized air flow and resonance terminating mounting system. Less resonance in all structures, lower compression and higher linearity, faster termination of excess energy and higher sound pressure capability make the 15S have more musical and dynamic capability than any other 5 1/2" we know of. Shielded for use near a CRT.



### TECHNICAL DATA:

Sensitivity 2.83V/1M	84.5dB	Lin. & max. excursion	±6.5 & ±9mm
Free air resonance Fs	30 Hz	Air gap flux density	-
DC resistance	5.8 ohm	Force factor BL Product	6.1 Tm
V.C. inductance	0.35 mH	Moving mass incl. air	13 g
Power 12dB@Hz	60W	Net weight	1.3 kg
Effective cone area	95 cm <sup>2</sup>	Vas	28 ltrs
V.C. diameter	38 mm	Qms	4.9
V.C. height	-	Qes	0.38
Air gap height	-	Qts	0.35

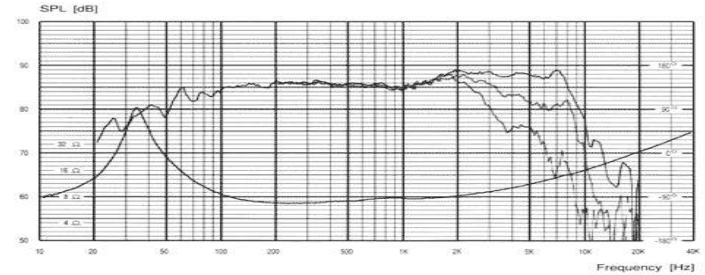

## 15W/4531G-00 4Ω

The 15W/4531G-01 is a 5 1/2" Revelator mid/woofer. It features a slit-paper uncoated non-resonant cone and dust cap structure, dynamic linear suspension, SD-1 magnet system, "Grasshopper" cast chassis with maximized air flow, glass fiber voice coil former and resonance terminating mounting system. The 15W/4531G provides a more extended frequency response than it's brothers, but still fantastic bass down to the mid 50's in a vented enclosure. This version is only available in 4 ohm.



### TECHNICAL DATA:

Sensitivity 2.83V/1M	87 dB	Lin. & max. excursion	±6.5 & ±9mm
Free air resonance Fs	39.5 Hz	Air gap flux density	-
DC resistance	3.4 ohm	Force factor BL Product	5.7 Tm
V.C. inductance	0.25 mH	Moving mass incl. air	13 g
Power 12dB@Hz	60W	Net weight	1.6 kg
Effective cone area	95 cm <sup>2</sup>	Vas	16 ltrs
V.C. diameter	38 mm	Qms	4.6
V.C. height	-	Qes	0.34
Air gap height	-	Qts	0.32

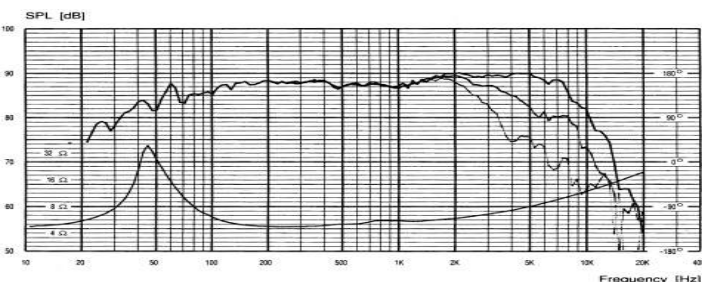

## 15W/8530K-00/01

The 15W/8530K-01 is a 5 1/2" Revelator mid/woofer. It features a non-resonant cone and dust cap structure, dynamic linear suspension, SD-1 magnet system, "Grasshopper" cast chassis with maximized air flow and resonance terminating mounting system. Less resonance in all structures, lower compression and higher linearity, faster termination of excess energy and higher sound pressure capability make the 15W have more musical and dynamic capability than any other 5 1/2" we know of. Wonderful bass in a small box!



### TECHNICAL DATA:

Sensitivity 2.83V/1M	85.5/84.5dB	Lin. & max. excursion	±6.5 & ±9mm
Free air resonance Fs	30 Hz	Air gap flux density	-
DC resistance	5.8 ohm	Force factor BL Product	7/6.1 Tm
V.C. inductance	0.35 mH	Moving mass incl. air	13 g
Power 12dB@Hz	60W	Net weight	1.6/1.3 kg
Effective cone area	95 cm <sup>2</sup>	Vas	28 ltrs
V.C. diameter	38 mm	Qms	4.9
V.C. height	-	Qes	0.29/0.38
Air gap height	-	Qts	0.27/0.35

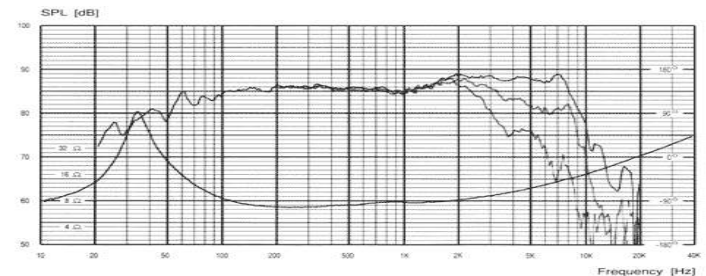





## 18S/8531G 8Ω

The 18W/8531G-00 is a 7" Revelator mid/woofer. It features a non-resonant cone and dust cap structure, dynamic linear suspension, SD-1 magnet system, "Grasshopper" cast chassis with maximized air flow and resonance terminating mounting system. Less resonance in all structures, lower compression and higher linearity, faster termination of excess energy and higher sound pressure capability. The magnet system has been shielded for use in A/V systems. **SHIELDED MAGNET**



TECHNICAL DATA:			
Sensitivity 2.83V/1M	87dB	Lin. & max. excursion	±6.5 / ±11 mm
Free air resonance F <sub>s</sub>	27.5 Hz	Air gap flux density	-
DC resistance	5.8 ohm	Force factor BL Product	6.7 Tm
V.C. inductance	0.35 mH	Moving mass incl. air	15.5 g
Power	70W	Net weight	1.75 kg
Effective cone area	150 cm <sup>2</sup>	Vas	61 ltrs
V.C. diameter	38 mm	Q <sub>ms</sub>	5.0
VC height	-	Q <sub>es</sub>	0.39
Air gap	-	Q <sub>ts</sub>	0.36

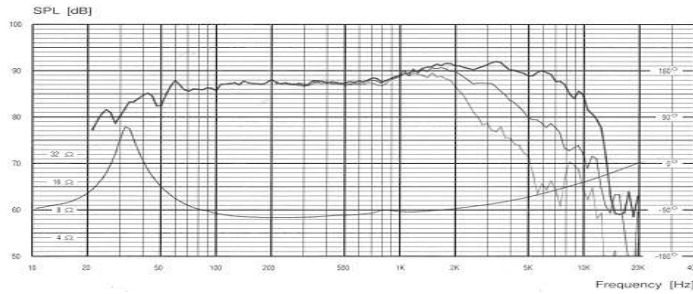

## 18W/4531G 4Ω

The 18W/4531G-00 is a 7" Revelator mid/woofer. It features a non-resonant cone and dust cap structure, dynamic linear suspension, SD-1 magnet system, "Grasshopper" cast chassis with maximized air flow and resonance terminating mounting system. Less resonance in all structures, lower compression and higher linearity, faster termination of excess energy and higher sound pressure capability. The 18W/4531G should have an F<sub>3</sub> of about 65Hz sealed and 40Hz vented.



TECHNICAL DATA:			
Sensitivity 2.83V/1M	90dB	Lin. & max. excursion	±6.5 / ±11 mm
Free air resonance F <sub>s</sub>	33 Hz	Air gap flux density	-
DC resistance	3.4 ohm	Force factor BL Product	5.7 Tm
V.C. inductance	0.3 mH	Moving mass incl. air	17.5 g
Power	70W	Net weight	1.75 kg
Effective cone area	150 cm <sup>2</sup>	Vas	42 ltrs
V.C. diameter	38 mm	Q <sub>ms</sub>	5.2
VC height	-	Q <sub>es</sub>	0.38
Air gap	-	Q <sub>ts</sub>	0.35

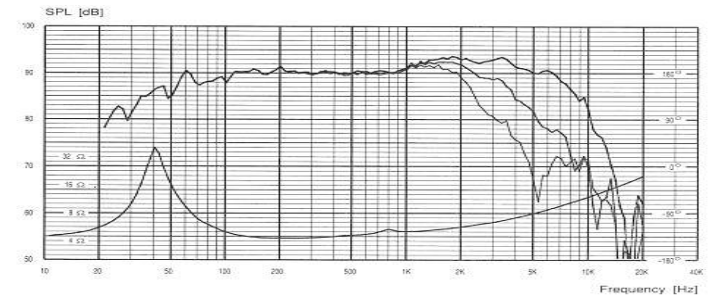

## 18W/8531G 8Ω

The 18W/8531G-00 is a 7" Revelator mid/woofer. It features a non-resonant cone and dust cap structure, dynamic linear suspension, SD-1 magnet system, "Grasshopper" cast chassis with maximized air flow and resonance terminating mounting system. Less resonance in all structures, lower compression and higher linearity, faster termination of excess energy and higher sound pressure capability. The 18W/8531G should have an F<sub>3</sub> of about 50Hz sealed and 35Hz vented.



TECHNICAL DATA:			
Sensitivity 2.83V/1M	87dB	Lin. & max. excursion	±6.5 / ±11 mm
Free air resonance F <sub>s</sub>	27.5 Hz	Air gap flux density	-
DC resistance	5.8 ohm	Force factor BL Product	6.7 Tm
V.C. inductance	0.35 mH	Moving mass incl. air	15.5 g
Power	70W	Net weight	1.75 kg
Effective cone area	150 cm <sup>2</sup>	Vas	61 ltrs
V.C. diameter	38 mm	Q <sub>ms</sub>	5.0
VC height	-	Q <sub>es</sub>	0.39
Air gap	-	Q <sub>ts</sub>	0.36

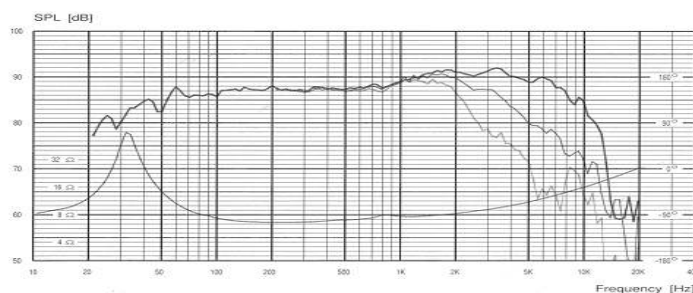

## 18W/16531G 16Ω

The 18W/16531G-00 is a 7" Revelator mid/woofer. It features a non-resonant cone and dust cap structure, dynamic linear suspension, SD-1 magnet system, "Grasshopper" cast chassis with maximized air flow and resonance terminating mounting system. Less resonance in all structures, lower compression and higher linearity, faster termination of excess energy and higher sound pressure capability. This is a 16 ohm woofer, a perfect choice for multiple woofer systems.



TECHNICAL DATA:			
Sensitivity 2.83V/1M	83dB	Lin. & max. excursion	±6.5 / ±11 mm
Free air resonance F <sub>s</sub>	27 Hz	Air gap flux density	-
DC resistance	12.2 ohm	Force factor BL Product	9.4 Tm
V.C. inductance	0.6 mH	Moving mass incl. air	18 g
Power	60W	Net weight	1.75 kg
Effective cone area	150 cm <sup>2</sup>	Vas	61.5 ltrs
V.C. diameter	38 mm	Q <sub>ms</sub>	4.7
VC height	-	Q <sub>es</sub>	0.42
Air gap	-	Q <sub>ts</sub>	0.39

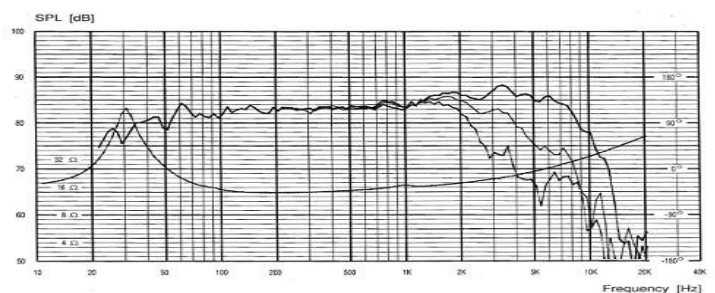



## 22W/8851T

The 22W/8851T is a new addition to the Revelator line. This robust 8" woofer was designed to provide deep and accurate bass in a small enclosure. This woofer features a 2" voice coil on a titanium former, a low loss linear suspension and symmetric drive motor. The deep set hard paper cone is attached to the frame with a minimal reflection rubber surround. The 9mm X-max insures good linear travel.

We suggest a 1.2 cubic foot enclosure with a 2.5"Ø vent by 8" long for and F3 of 38Hz.



### TECHNICAL DATA:

Sensitivity 2.83V/1M	88 dB	Lin. & max. excursion	±9 / ±14 mm
Free air resonance Fs	21 Hz	Air gap flux density	-
DC resistance	6.2 ohm	Force factor BL Product	9.9 Tm
V.C. inductance	0.35 mH	Moving mass incl. air	31 g
Power	170 W	Net weight	3.6 kg
Effective cone area	220 cm <sup>2</sup>	Vas	127 ltrs
V.C. diameter	50 mm	Qms	5.1
VC height	-	Qes	0.26
Air gap	-	Qts	0.25

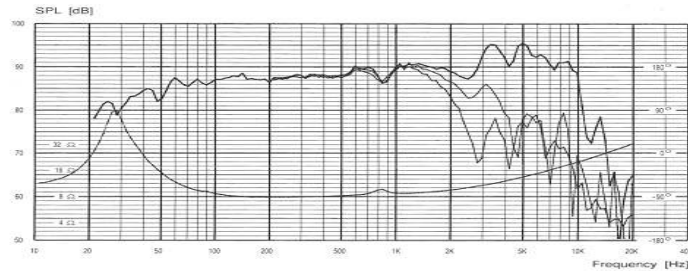

## 26W/8861T

The 26W/8861T is a new addition to the Revelator line. This robust 10" woofer was designed to provide deep and accurate bass in a small enclosure. This woofer features a 2" voice coil on a titanium former, a low loss linear suspension and symmetric drive motor. The deep set hard paper cone is attached to the frame with a minimal reflection rubber surround. The 9mm X-max insures good linear travel.

We suggest a 2.75 cubic foot enclosure with a 3"Ø vent by 9.5" long for and F3 of 30Hz.



### TECHNICAL DATA:

Sensitivity 2.83V/1M	88.5 dB	Lin. & max. excursion	±9 / ±14 mm
Free air resonance Fs	19 Hz	Air gap flux density	-
DC resistance	6.2 ohm	Force factor BL Product	9.9 Tm
V.C. inductance	0.35 mH	Moving mass incl. air	43.5 g
Power	170 W	Net weight	3.7 kg
Effective cone area	320 cm <sup>2</sup>	Vas	234 ltrs
V.C. diameter	50 mm	Qms	5.2
VC height	-	Qes	0.33
Air gap	-	Qts	0.31

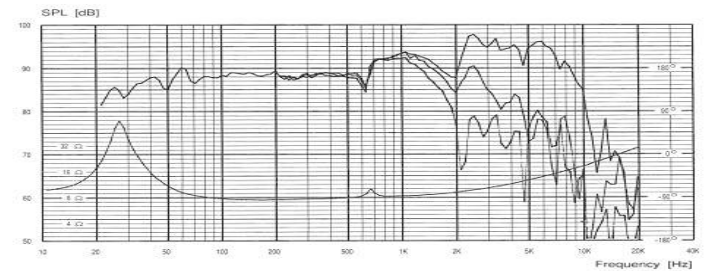

## 26W/4867T 4Ω

The 26W/4867T a new black Aluminum cone woofer. Aluminum is a good material for subwoofer cones, very stiff and light. These cones reduce distortion and also help cool the voice coil, by conducting heat away from the coil. This woofer has a low loss suspension for increased bass response and the SD-1 motor system for less intermodulation distortion. Very rigid cast frame, large windows.

We recommend a 2.5 cubic foot enclosure with a 3" diameter vent by 10" long, the F3 would be about 29Hz.



### TECHNICAL DATA:

Sensitivity 2.83V/1M	89 dB	Lin. & max. excursion	±9 / ±14 mm
Free air resonance Fs	18 Hz	Air gap flux density	-
DC resistance	3.7 ohm	Force factor BL Product	8.3 Tm
V.C. inductance	0.25 mH	Moving mass incl. air	51 g
Power	170 W	Net weight	3.7 kg
Effective cone area	320 cm <sup>2</sup>	Vas	223 ltrs
V.C. diameter	50 mm	Qms	5.8
VC height	-	Qes	0.31
Air gap	-	Qts	0.30

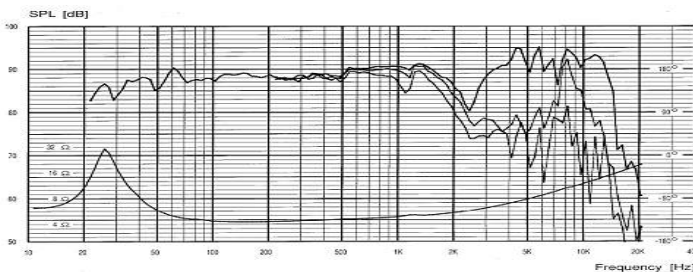

## 26W/8867T 8Ω

The 26W/8867T a new black Aluminum cone woofer. Aluminum is a good material for subwoofer cones, very stiff and light. These cones reduce distortion and also help cool the voice coil, by conducting heat away from the coil. This woofer has a low loss suspension for increased bass response and the SD-1 motor system for less intermodulation distortion. Very rigid cast frame, large windows.

We recommend a 2.3 cubic foot enclosure with a 3" diameter vent by 11" long, the F3 would be about 29Hz.



### TECHNICAL DATA:

Sensitivity 2.83V/1M	87 dB	Lin. & max. excursion	±9 / ±14 mm
Free air resonance Fs	19 Hz	Air gap flux density	-
DC resistance	5.8 ohm	Force factor BL Product	11.2 Tm
V.C. inductance	0.4 mH	Moving mass incl. air	57 g
Power	170 W	Net weight	3.7 kg
Effective cone area	320 cm <sup>2</sup>	Vas	179 ltrs
V.C. diameter	50 mm	Qms	4.5
VC height	-	Qes	0.31
Air gap	-	Qts	0.29

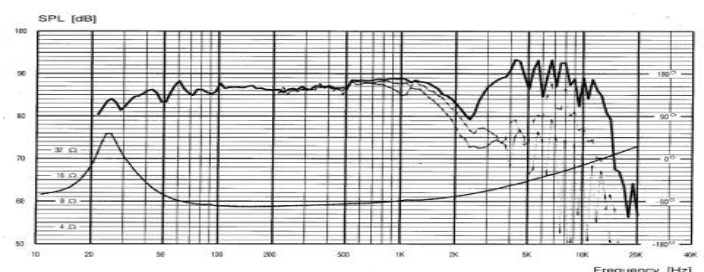





## 23W/4557T 4Ω

The 23W/4557T is a very high end subwoofer, designed to be used with a passive radiator in a small enclosure. This sub has a very rigid aluminum cone, low loss rubber surround and cast frame. The passive radiator is similar, but with a weight attached to the bass of the cone. The 23W/4557T is using the SD-1 motor system. There are gold plated binding posts and the woofer is covered by a decorative rubber cap.

Frequency response with the passive is down to 25Hz. One cubic foot sealed has an F3 of 33Hz.



### TECHNICAL DATA:

Sensitivity 2.83V/1M	82 dB	Lin. & max. excursion	±13 / ±20 mm
Free air resonance F <sub>s</sub>	20.5 Hz	Air gap flux density	-
DC resistance	3.45 ohm	Force factor BL Product	9.3 Tm
V.C. inductance	0.45 mH	Moving mass incl. air	101 g
Power	225 W	Net weight	4.6 kg
Effective cone area	232 cm <sup>2</sup>	Vas	45.6 ltrs
V.C. diameter	50 mm	Q <sub>ms</sub>	4.8
VC height	-	Q <sub>es</sub>	0.52
Air gap	-	Q <sub>ts</sub>	0.47

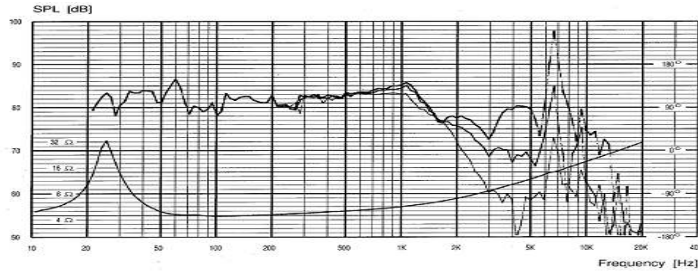

## 23W/0-00 Passive

This is the passive radiator intended for use with the 23W/4557T active woofer. We recommend putting both in a 1.0 cubic foot enclosure. This should yield a bass response down to 25Hz. The woofer should still be linear at 180 watts and have an output of about 104dB.

The curve below is a simulation of the woofer and passive radiator in a 1.0 cubic foot box. This was done in Bass Box Pro by Harris Technologies.



### TECHNICAL DATA:

Sensitivity 2.83V/1M	- dB	max. excursion	±20 mm
Free air resonance F <sub>s</sub>	10.5 Hz	Air gap flux density	-
DC resistance	- ohm	Force factor BL Product	- Tm
V.C. inductance	- mH	Moving mass incl. air	400 g
Power	- W	Net weight	1.2 kg
Effective cone area	232 cm <sup>2</sup>	Vas	43.5 ltrs
V.C. diameter	- mm	Q <sub>ms</sub>	11.5
VC height	-	Q <sub>es</sub>	-
Air gap	-	Q <sub>ts</sub>	-

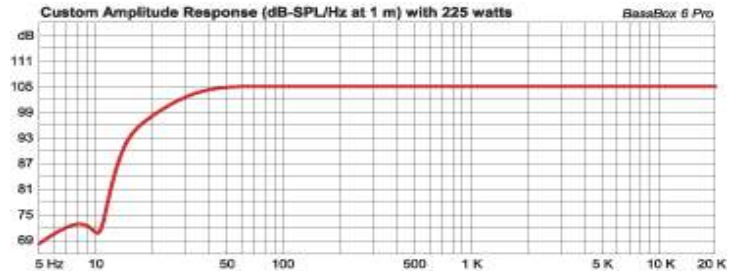

## D2008/8512

Double chambered 3/4" damped textile dome tweeter. The voice coil is a precision wound aluminum wire with a 27 strand tinsel braid for a lower resonance. The magnet system is a special high flux ferrite with vented pole plates. The surround of the diaphragm is damped to reduce distortion.

This tweeters extremely linear response, low distortion and wide dispersion make it an attractive choice for any speaker system.



### TECHNICAL DATA:

Characteristic sensitivity	90dB 1W/1m	Lin. & max. excursion	±0.8 / ±1.2 mm
Free air resonance f <sub>s</sub>	1000 Hz	Air gap flux density	1.6 T
DC resistance	5.8 ohm	Force factor BL Product	1.8 Tm
V.C. inductance	0.08 mH	Moving mass incl. air	0.20 g
Power 12db@Hz	150W@4K	Net weight	0.4 kg
Effective cone area	3.8 cm <sup>2</sup>	Vas	-
V.C. diameter	19.0 mm	Q <sub>ms</sub>	-
V.C. height	3.2 mm	Q <sub>es</sub>	-
Air gap height	1.6 mm	Q <sub>ts</sub>	-

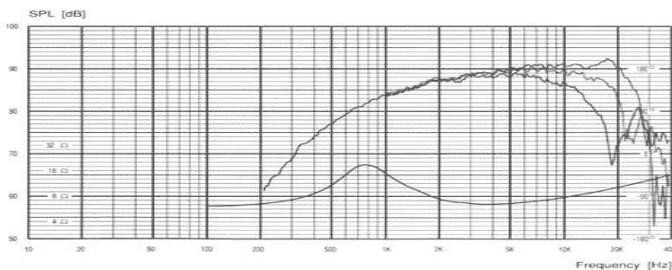

## D2010/8513

Similar to the D2008, but with several improvements, a foam impregnated front face plate and a lower resonance. Double chambered 3/4" damped textile dome tweeter with the same diaphragm and voice coil as the D2008.

The lower resonance of this driver will allow it to be crossed over lower than most other 3/4" dome tweeters, yet retain the low distortion and clarity of a 3/4" dome. We recommend a steeper x-over slope be used when the x-over point is below 3KHz.



### TECHNICAL DATA:

Sensitivity 2.83V/1M	90dB	Lin. & max. excursion	±0.7 / ±1.2 mm
Free air resonance F <sub>s</sub>	800 Hz	Air gap flux density	-
DC resistance	5.7 ohm	Force factor BL Product	2.4 Tm
V.C. inductance	0.07 mH	Moving mass incl. air	0.25 g
Power 12db@Hz	150W@4K	Net weight	0.4 kg
Effective cone area	3.8 cm <sup>2</sup>	Vas	-
V.C. diameter	19 mm	Q <sub>ms</sub>	-
V.C. height	-	Q <sub>es</sub>	-
Air gap height	-	Q <sub>ts</sub>	-

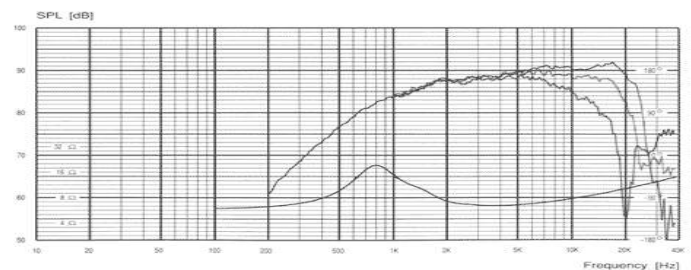





## D2905/9300 1" Dome Tweeter

The D2905/9300 is a 1" textile dome tweeter with a very flat frequency response and low distortion. The D2905/9300 achieves a lower resonance and increased clarity by using several coatings of damping material on the dome and chambering behind the dome. Both these damping factors and the use of a light magnetic fluid, reduce the resonances as much as possible, while reducing compression affects. This tweeter's linear response and openness make it a good choice for any system.



TECHNICAL DATA:			
Sensitivity 2.83V/1M	90dB	Lin. & max. excursion	$\pm 0.4 / \pm 1.5$ mm
Free air resonance Fs	650 Hz	Air gap flux density	-
DC resistance	4.7 ohm	Force factor BL Product	3.5 Tm
V.C. inductance	0.08 mH	Moving mass incl. air	0.45 g
Power 12dB@Hz	150W@2.5K	Net weight	0.7 kg
Effective cone area	8.5 cm <sup>2</sup>	Vas	-
V.C. diameter	28 mm	Qms	-
V.C. height	-	Qes	-
Air gap height	-	Qts	-

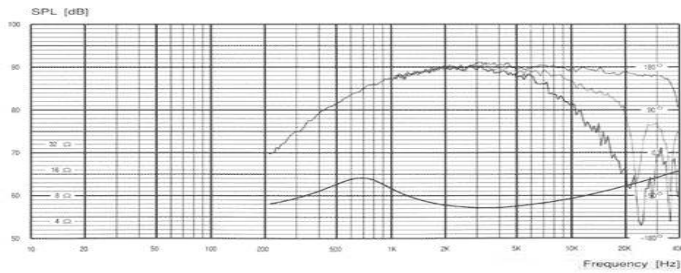

## D2905/9500 1" Dome Tweeter

The D2905/9500 is similar to the D2905/9300, but with non-resonant chamber. The optimized pole piece geometry reduces flow resistance and the anti-resonator-plug in the rear chamber eliminates turbulence. A light ferrofluid is used in the air gap to ensure optimal linear mechanical behavior and minimal micro-dynamic non-linearity. This tweeter has a smooth transparent sound and very low levels of distortion. A perfect choice for any high end system.



TECHNICAL DATA:			
Sensitivity 2.83V/1M	90dB	Lin. & max. excursion	$\pm 0.4 / \pm 1.5$ mm
Free air resonance Fs	550 Hz	Air gap flux density	-
DC resistance	4.7 ohm	Force factor BL Product	3.5 Tm
V.C. inductance	0.08 mH	Moving mass incl. air	0.45 g
Power 12dB@Hz	150W@2.5K	Net weight	0.7 kg
Effective cone area	8.5 cm <sup>2</sup>	Vas	-
V.C. diameter	28 mm	Qms	-
V.C. height	-	Qes	-
Air gap height	-	Qts	-

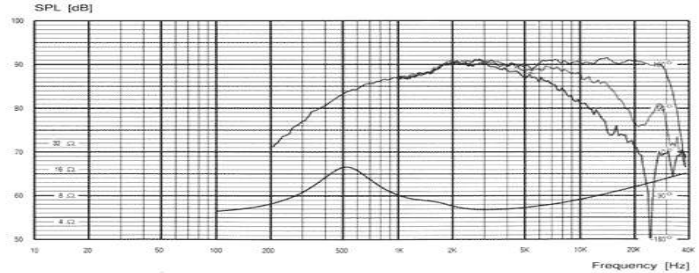

## D3806/8200 1.5" Dome Mid/Tweeter

The D3806/8200 is a dome midrange/tweeter. The magnet system incorporates the Symmetric Drive technology. The pole piece is vented and damped by a porous foam pad for correct tuning and coupling of the rear chamber. The surround is partially covered by a front ring to minimize distortion and improve phase response. The low resonance allows for a low crossover point. The frequency response is smooth and the tweeter has good dispersion.



TECHNICAL DATA:			
Sensitivity 2.83V/1M	90dB	Lin. & max. excursion	$\pm 0.4 / \pm 1$ mm
Free air resonance Fs	450 Hz	Air gap flux density	-
DC resistance	5.7 ohm	Force factor BL Product	3.8 Tm
V.C. inductance	0.04 mH	Moving mass incl. air	0.90 g
Power 12dB@Hz	100W@1kHz	Net weight	1.2 kg
Effective cone area	14 cm <sup>2</sup>	Vas	-
V.C. diameter	38 mm	Qms	-
V.C. height	-	Qes	-
Air gap height	-	Qts	-

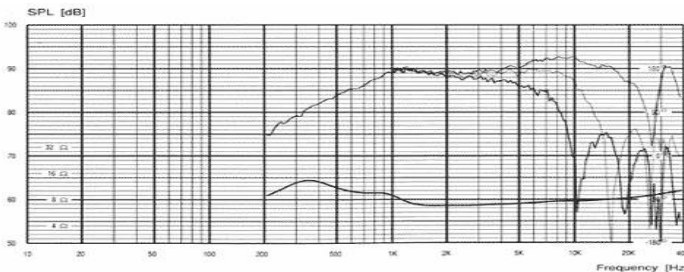

## 13M/8636

This midrange has a very low resonance frequency for its size and can be used in an extremely wide band width. It features a magnesium cast frame, Kevlar® cone and rubber surround. The magnet system uses the Scan-speak Symmetric Drive short circuiting system for less distortion and a linear impedance.

The Kevlar® cone provides good transient response. Stiff and light, this cone provides very detailed reproduction. As you can see from the rising response, it is not overly damped.



TECHNICAL DATA:			
Sensitivity 2.83V/1M	86.5dB	Lin. & max. excursion	$\pm 1.5 / \pm 5$ mm
Free air resonance Fs	77 Hz	Force factor BL Product	6.0 Tm
DC resistance	5.8 ohm	Moving mass incl. air	4.6 g
V.C. inductance	0.1 mH	Net weight	1.2 kg
Power 12dB@Hz	100W@300Hz	Vas	3 liters
Effective cone area	48 cm <sup>2</sup>	Qms	2.80
V.C. diameter	38.0 mm	Qes	0.36
V.C. height	9 mm	Qts	0.32
Air gap height	6 mm		

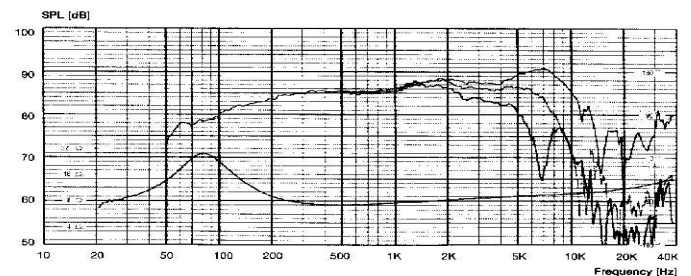



## 13M/8640

This midrange has a very low resonance frequency for its size and can be used in an extremely wide band width. It features a magnesium cast frame, paper cone and rubber surround. The magnet system uses the Scan-speak Symmetric Drive short circuiting system for less distortion and a linear impedance.

This driver has a rich full-bodied sound, detailed and clean, with a natural tonal balance. It's intended uses are high quality 3-way systems that require low crossover frequencies.



### TECHNICAL DATA:

Sensitivity 2.83V/1M	87.5dB	Lin. & max. excursion	±1.5 / ±5 mm
Free air resonance Fs	64 Hz	Force factor BL Product	6.0 Tm
DC resistance	5.8 ohm	Moving mass incl. air	4.1 g
V.C. inductance	0.1 mH	Net weight	1.2 kg
Power 12db@300Hz	100W@300Hz	Vas	5 liters
Effective cone area	48 cm <sup>2</sup>	Qms	2.70
V.C. diameter	38.0 mm	Qes	0.27
V.C. height	9 mm	Qts	0.24
Air gap height	6 mm		

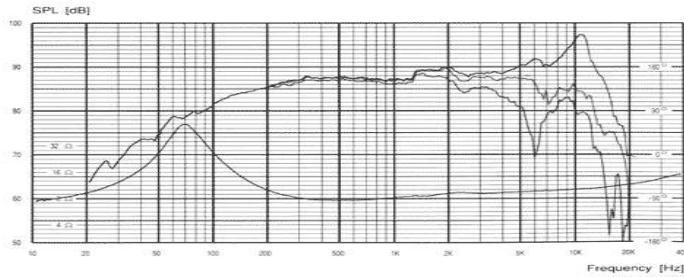

## 18S/8535

### 7" Carbon/Paper Woofer

The 18S/8535 is a **SHIELDED** woofer designed with the SD-1 magnet system, which reduces clipping distortion generated as the drive unit exceeds its linear excursion. The carbon fibre filled paper cone is impregnated and coated to damp resonance normally associated with stiff cones. The low loss linear suspension, especially the rubber surround, combines dynamic linearity with low coloration. A 20 liter sealed enclosure yields an impressive 3dB down point of 45Hz.



### TECHNICAL DATA:

Sensitivity 2.83V/1M	86.5dB	Lin. & max. excursion	±5 / ±10 mm
Free air resonance Fs	26 Hz	Force factor BL Product	5.6 Tm
DC resistance	5.8 ohm	Moving mass incl. air	15.5 g
V.C. inductance	0.3 mH	Net weight	2.5 kg
Power	70W	Vas	72 liters
Effective cone area	145 cm <sup>2</sup>	Qms	2.50
V.C. diameter	38 mm	Qes	0.47
V.C. height	15 mm	Qts	0.40
Air gap height	5 mm		

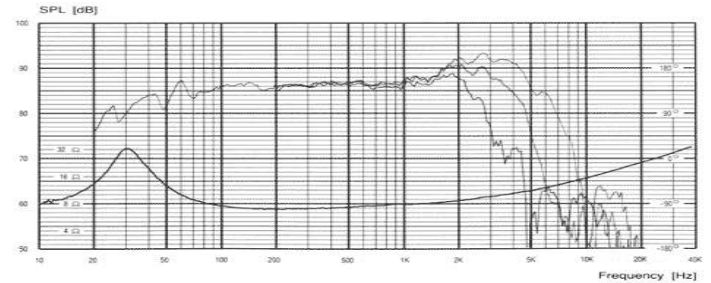

## 18W/8535

### 7" Carbon/Paper Woofer

The 18W/8535 woofer features the SD-1 magnet system which almost eliminates modulation and dynamic distortion and reduce clipping when the drivers is taken beyond linear excursion. The carbon fiber filled paper cone is impregnated and coated to damp resonance. The low loss rubber surround combines dynamic linearity with low coloration. The smaller magnet increases the Qts making this driver a good choice for a sealed enclosure.



### TECHNICAL DATA:

Sensitivity 2.83V/1M	86.5dB	Lin. & max. excursion	±5 / ±10 mm
Free air resonance Fs	26 Hz	Force factor BL Product	5.7 Tm
DC resistance	5.8 ohm	Moving mass incl. air	15.5 g
V.C. inductance	0.3 mH	Net weight	2.5 kg
Power	70W	Vas	72 liters
Effective cone area	145 cm <sup>2</sup>	Qms	2.50
V.C. diameter	38 mm	Qes	0.45
V.C. height	15 mm	Qts	0.38
Air gap height	5 mm		

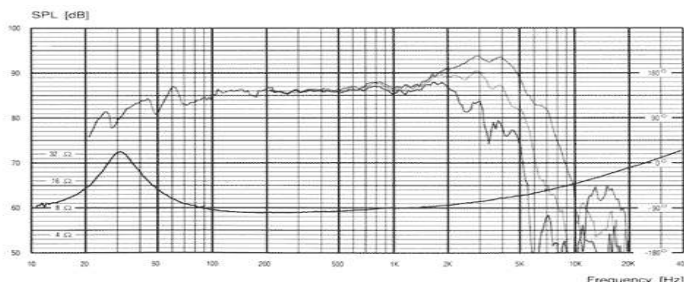

## 18W/8542

### 7" Paper Cone Woofer

This 7" woofer features a coated paper cone that delivers very smooth and warm reproduction with excellent detailing. We recommend this driver for high quality 2-way systems of bass reflex design. This driver has the SD magnet system, magnesium cast frame, aluminum former and wire. The surround is a double coated foam material with long term stability.



### TECHNICAL DATA:

Sensitivity 2.83V/1M	89dB	Lin. & max. excursion	±6.5 / ±10 mm
Free air resonance fs	30 Hz	Air gap flux density	1.1T
DC resistance	5.5 ohm	Force factor BL Product	7.8 Tm
V.C. inductance	0.2 mH	Moving mass incl. air	15 g
Power	70W	Net weight	2.4 kg
Effective cone area	143 cm <sup>2</sup>	Vas	49 ltr
V.C. diameter	42 mm	Qms	1.70
V.C. height	19 mm	Qes	0.26
Air gap height	6 mm	Qts	0.22

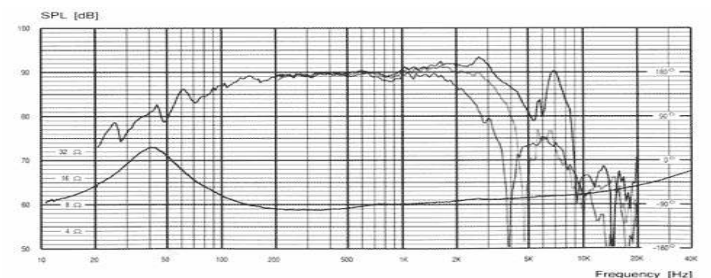





## 18W/8543

### 7" Poly Cone Woofer

The 18W/8543 is a Polypropylene cone woofer, that provides a deep and tight bass combined with excellent midrange clarity. This driver will perform well in a 2-way bass reflex system. The frame is cast magnesium with a resonance free PVC/rubber surround. The long throw all aluminum voice coil is joined to the basket with a linear spider.



#### TECHNICAL DATA:

Sensitivity 2.83V/1M	88.5dB	Lin. & max. excursion	±6.5 / ±10 mm
Free air resonance fs	30 Hz	Air gap flux density	1.1 T
DC resistance	5.5 ohm	Force factor BL Product	7.8 Tm
V.C. inductance	0.2 mH	Moving mass incl. air	15 g
Power	80W	Net weight	2.4 kg
Effective cone area	143 cm <sup>2</sup>	Vas	49 liters
V.C. diameter	42 mm	Qms	1.40
V.C. height	19 mm	Qes	0.26
Air gap height	6 mm	Qts	0.22

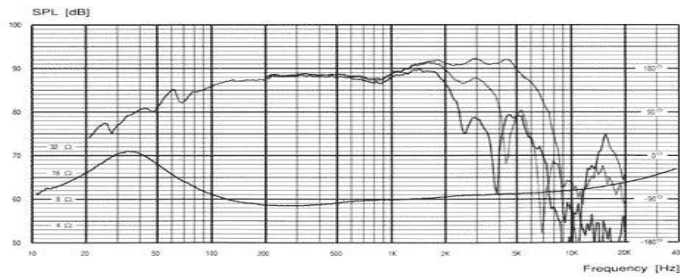

## 18W/8545

### 7" Carbon fibre Paper Woofer

This 7" features the heavily damped and carbon fibre impregnated paper cone that dampens resonances normally associated with stiff cones. The magnet system is the new SD-1 system which eliminates modulation and dynamic distortion, as well as clipping distortion created as it exceeds its maximum linear excursion. These designs all together make a drive unit with a very "open" sound with excellent detailing combined with low coloration and very precise imaging. Cast frame, rubber surround.



#### TECHNICAL DATA:

Sensitivity 2.83V/1M	88dB	Lin. & max. excursion	±6.5 / ±10mm
Free air resonance Fs	28 Hz	Force factor BL Product	8.0 Tm
DC resistance	5.5 ohm	Moving mass incl. air	20 g
V.C. inductance	0.4 mH	Net weight	2.3 kg
Power	100W	Vas	48 liters
Effective cone area	145 cm <sup>2</sup>	Qms	2.30
V.C. diameter	42 mm	Qes	0.30
V.C. height	19 mm	Qts	0.27
Air gap height	6 mm		

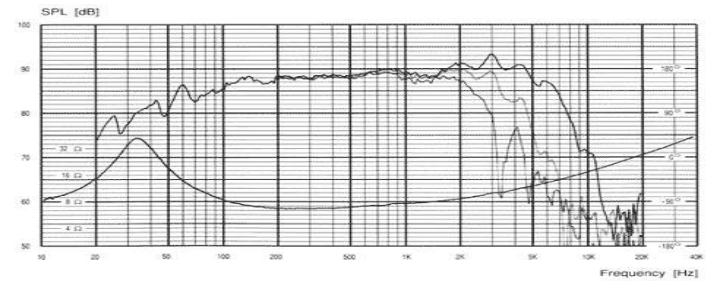

## 18W/8545K

### 7" Carbon fibre Paper Woofer

This 7" features the heavily damped and carbon fibre impregnated paper cone that dampens resonances normally associated with stiff cones. The magnet system is the new SD-1 system which eliminates modulation and dynamic distortion, as well as clipping distortion created as it exceeds its maximum linear excursion. This driver uses a fiberglass voice coil former. This is also a good driver for autousound applications.

Try it in a 1/2 cubic foot box with a 1.5" diameter vent by 5.2" long, f3 48Hz.



#### TECHNICAL DATA:

Sensitivity 2.83V/1M	87.5dB	Lin. & max. excursion	±6.5 / ±10mm
Free air resonance Fs	28 Hz	Force factor BL Product	8.2 Tm
DC resistance	5.5 ohm	Moving mass incl. air	20.5 g
V.C. inductance	0.4 mH	Net weight	2.4 kg
Power	100W	Vas	48 liters
Effective cone area	145 cm <sup>2</sup>	Qms	5.20
V.C. diameter	42 mm	Qes	0.30
V.C. height	19 mm	Qts	0.28
Air gap height	6 mm		

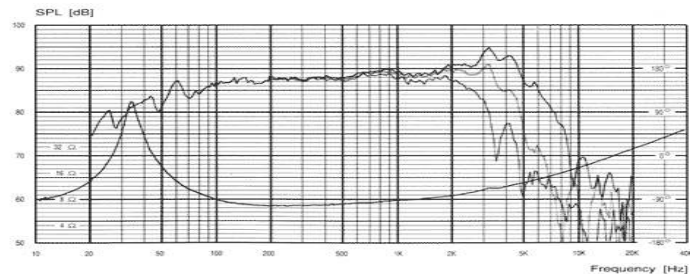

## 18W/8546

### 7" Kevlar Woofer

This new 7" Kevlar cone magnesium cast frame woofer features the new SD-1 magnet system, that eliminates modulation and dynamic distortion, as well as lowering clipping distortion caused when the driver exceeds its linear excursion. The new magnet system coupled with a new non resonant low loss linear suspension, gives you a drive unit with a very "open" sound with excellent dynamic range and detailing combined with low coloration and very precise imaging.



#### TECHNICAL DATA:

Sensitivity 2.83V/1M	88dB	Lin. & max. excursion	±6.5 / ±10 mm
Free air resonance Fs	22 Hz	Force factor BL Product	8.0 Tm
DC resistance	5.5 ohm	Moving mass incl. air	18.5 g
V.C. inductance	0.4 mH	Net weight	2.4 kg
Power	100W	Vas	84 liters
Effective cone area	145 cm <sup>2</sup>	Qms	1.70
V.C. diameter	42 mm	Qes	0.22
V.C. height	19 mm	Qts	0.19
Air gap height	6 mm		

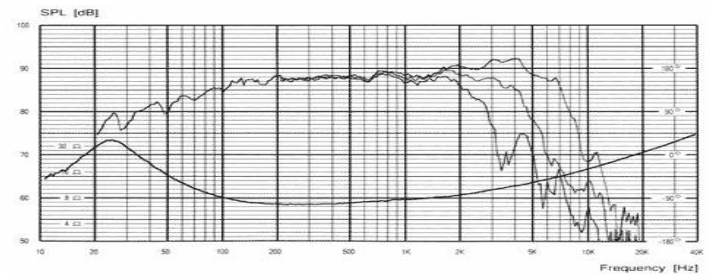





## 21W/8554 8" Kevlar Woofer

This 8" cast magnesium/Aluminum frame woofer features a hand coated cast Kevlar cone with a hand coated foam surround. The magnet system uses the patented SD copper cap and symmetrically shaped pole piece for lower distortion. The damped cone and surround offer a good balance between clarity and tonal balance.

This driver is fast and accurate even with the most demanding transients. A good choice for any high end system.



### TECHNICAL DATA:

Sensitivity 2.83V/1M	90dB	Lin. & max. excursion	±6.5 / ±10 mm
Free air resonance Fs	23 Hz	Force factor BL Product	8.0 Tm
DC resistance	5.5 ohm	Moving mass incl. air	20.5 g
V.C. inductance	0.2 mH	Net weight	2.4 kg
Power	110W	Vas	160 liters
Effective cone area	220 cm <sup>2</sup>	Qms	1.70
V.C. diameter	42 mm	Qes	0.25
V.C. height	19 mm	Qts	0.22
Air gap height	6 mm		

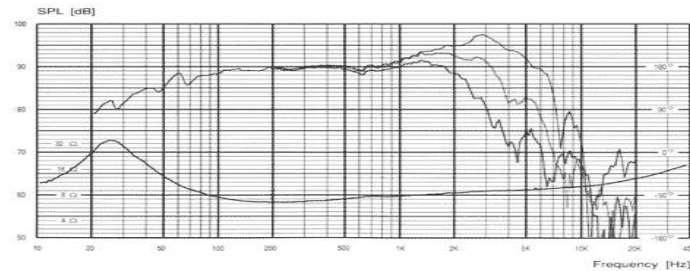

## 21W/8555 & 21W/8555-01

This 8" features a very stiff paper cone, heavily impregnated to reduce resonance's normally associated with stiff cones. The magnet system is the new SD-1 system which eliminates modulation and dynamic distortion, as well as clipping distortion created as it exceeds its maximum linear distortion. The low-loss rubber surround is designed for better dynamic capability, detailing and less compression. Both the 21W/8555 and 21W/8555-01 will perform well either sealed or vented.



### TECHNICAL DATA:

Sensitivity 2.83V/1M	87 / 87.5 dB	Lin. & max. excursion	±6.5 / ±12 mm
Free air resonance Fs	20 / 19 Hz	BL	8.2 / 9.3Tm
DC resistance	5.5 Ω	Moving mass incl. air	32 / 36 g
V.C. inductance	0.4 / 0.6 mH	Net weight	2.40 kg
Power	100W	Vas	136 ltr
Effective cone area	220 cm <sup>2</sup>	Qms	4.50 / 4.80
V.C. diameter	42 mm	Qes	0.33 / 0.27
V.C. height	19 mm	Qts	0.31 / 0.26
Air gap height	6 mm		

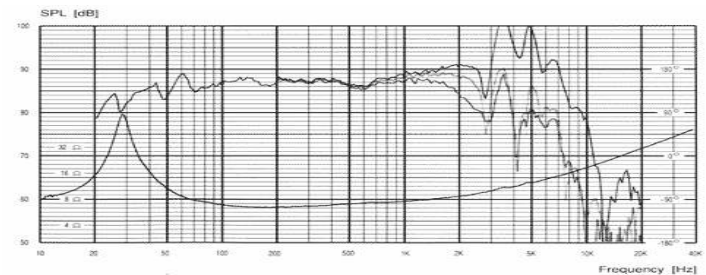

## 25W/8565 & 25W/8565-01

This 10" features a very stiff paper cone, heavily impregnated to reduce resonance's normally associated with stiff cones. The magnet system is the new SD-1 system which eliminates modulation and dynamic distortion, as well as clipping distortion created as it exceeds its maximum linear distortion. The low-loss rubber surround is designed for better dynamic capability, detailing and less compression. Both the 25W/8565 and 25W/8565-01 will perform well either sealed or vented. systems of the highest quality.



### TECHNICAL DATA:

Sensitivity 2.83V/1M	88 / 88 dB	Lin. & max. excursion	±6.5 / ±12 mm
Free air resonance Fs	20 / 19 Hz	BL	8.2 / 9.3 Tm
DC resistance	5.5 Ω	Moving mass incl. air	43 / 47 g
V.C. inductance	0.4 / 0.6 mH	Net weight	2.6 kg
Power	100W	Vas	229 ltr
Effective cone area	330 cm <sup>2</sup>	Qms	5.40 / 5.60
V.C. diameter	42 mm	Qes	0.44 / 0.36
V.C. height	19 mm	Qts	0.41 / 0.34
Air gap height	6 mm		

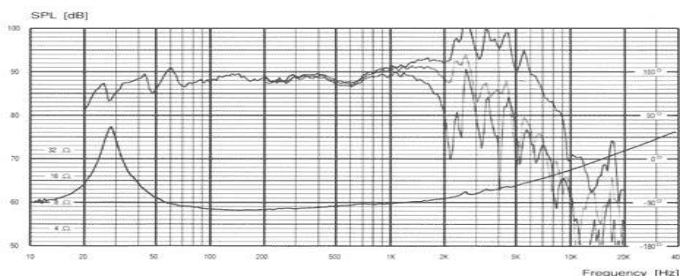

Driver Dimensions in Millimeters				
Unit	A	B	C	D
R2904/7000, D2904/7100	104	5.9	30.9	70
D2008/8512	92	3	38	69
D2010/8513	98	5	41	69
D2904/6000-00/01	59.5	3	29	41
D2904/9800	104.5	3	43	74
D2904/9400SE	104.5	3	41	74
D2905/9300, 9500, 9700	104.5	3	41	74
D2905/9900	130	5	48	90
D3806/8200	125	4	45	92
12M/4631G	115.5	3	48.4	92
13M/8636, 8640, 4535	130	6	48	100
15S/8530K-01	148	6	77	125
15W's	148	6	71	125
18S/8535	177	4	80	158
18S/8531G	182	5.5	86.2	158
18W/4531G, 8531G, 16531G	182	5.5	77	156
18W/8535, 8543, 8545/K, 8546	177	4	70	158
21W/8554	222	5	77	192
21W/8555's	222	5	81	192
22W/8851T	222	7	111	194
23W/4557T / Passive	255	6	135/73	225
25W's	255	6	86	228

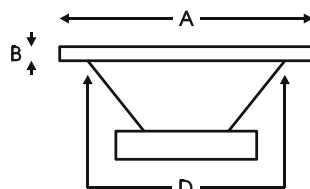

25.4mm = 1"  
 28.3 liters = 1 cubic foot  
 1 cubic foot = 1728 cubic inches  
 Box Volume = L x W x H  
 We can assist you with your speaker design.

## SEAS THOR KIT



THOR is the new top-of-the-line loudspeaker kit from SEAS. It is a full range, floor-standing system that provides the very highest level of acoustic performance.

This kit uses two W18E001 woofers and a single T25CF002 "MILLENNIUM" tweeter mounted in a D'Appolito configuration.

The enclosure uses a newly developed transmission line configuration, derived both from sophisticated computer modeling, and extensive experimentation. The line is tapered, and filled with Dacron stuffing. The two W18E001 woofers excite the line at slightly different points, smoothing the response and increasing the range of

bass output. Usable in-room bass response extends well into the low 30Hz range. Our cabinets are 45 1/2" T x 9" W x 14 1/4" D.

The crossover network is conventional except for a parallel circuit which suppresses the response peak due to the magnesium cone. The crossover frequency is 2.5kHz. Nordost 2-Flat wire supplied with kit.

THOR was designed by Dr. Joseph D'Appolito, who is world-renowned for his pioneering work on MTM-based loudspeaker configurations.

**Pair with cabinets \$1665 (Cherry, Clear or Black Oak)**

**Price per pair w/o cabinets \$1075.00**

**Upgraded crossovers (Goertz coils, Musicaps) Add \$200.00**

**Shielded Kit using W18E-001/TV woofers; Add \$31.86**

## SEAS ODIN MK3 KIT



The Odin Mk3 is a completely redesigned version of the very popular Odin kit, utilizing the latest drive unit technologies from the Excel product line. This kit uses two W18E001 woofers and a single T25CF002 "MILLENNIUM" tweeter mounted in a D'Appolito configuration.

The cabinet is a bass reflex design with the vent placed in the rear. This directs any potential vent noises away from the listener, and allows for minimum baffle area in the front. The port tube is supported by an internal baffle which helps maintain equal air flow on each end of the tube, and also serves as

additional cabinet bracing. The port tuning frequency is 31Hz. Cabinet dimensions are 22" T x 9 1/2" W x 14 1/4" D.

The crossover network is conventional except for a parallel circuit which suppresses the response peak due to the magnesium cone. The crossover frequency is 2.5kHz.

The Odin Mk3 was designed by Dr. Joseph D'Appolito, and was developed as a companion kit to the Thor transmission line system. It is equally transparent, a true audiophile speaker. A premium crossover is also available and is well worth the spatial highs it delivers.

**Pair with cabinets \$1455 (Cherry, Clear or Black Oak)**

**Price per pair w/o cabinets \$1075.00**

**Upgraded crossovers (Goertz coils, Musicaps) Add \$200.00**

**Shielded Kit using W18E-001/TV woofers; Add \$31.86**

## SEAS FROY MK3 KIT



The FROY MK3 is a new and improved version of the original FROY kit; utilizing the latest drive unit technologies from the Excel product line. This kit uses two W15CY001 woofers and a single T25CF002 "MILLENNIUM" tweeter mounted in a D'Appolito configuration.

The cabinet is a bass reflex design with the vent placed in the rear. This directs any potential vent noises away from the listener, and allows for minimum baffle area in the front. The port tube is constructed of two MDF boards which also serve as additional bracing for the cabinet. Our cabinet is 18 1/2" T x 8" W x 11 1/2" D.

The crossover network is conventional except for a parallel circuit which suppresses the response peak due to the magnesium cone. The crossover frequency is 2.2kHz.

The FROY Mk3 was designed by Murray Zeligman, who also designed the original FROY kit. Murray offers the following comments.

*"The vented box is tuned about 15% lower than the ubiquitous QB3 alignment to yield a better damped bass response. Several hundred hours of laboratory testing and listening have gone into this system. You literally can't tell where the woofers leave off and the tweeter begins."*

**Price per pair with cabinets \$1210.00 (Clear or Black Oak)**

**Price per pair w/o cabinets \$900.00**

## SEAS LOKI KIT



**8" W x 15" T x 11" D**

The Seas Loki kit features a 7" coaxial speaker, where the tweeter is coincidentally mounted at the base of the woofer cone. The type of configuration allows the listener to hear the sound emanating from the tweeter and woofer at the same time, from any listening position.

In a conventional system, depending on where you are listening from, you may here the individual components at different times, since you are physically at a different distance from each speaker component. This delay time, as small as it is, is perceivable by the listener. This is why most multiple loudspeaker systems have a "sweet spot", where the speaker sounds best. The Loki sounds fantastic from a very large listening area, there is virtually no sweet spot.

This little speaker is a big performer and will surprise you with its big speaker sound stage. We suggest considering it for Home Theater (it is also magnetically shielded), computer speakers, satellite speakers for a subwoofer or just as stand alone book shelf speakers.

The cabinets are made from 3/4" MDF (1" front baffle) with real wood veneer. They are finished on all sides and come with a black grill on the front. The kit includes; the Seas T18RE/XFCTV2 (H1333) coaxial loudspeaker, the finished cabinets, an input cup with gold plated brass terminals, the crossover with air core inductors and polypropylene capacitors, screws, wire and instructions.

**Price Each with cabinets \$225.00**

**Natural Cherry (not red), Maple or Black Painted Ash**

**Price Each w/o cabinets \$147.00**



The Art of Sound Perfection

Model	Size Description	Ω	Fs Hz	Qts	Vas Liters	X-max mm Peak	VC Ø mm	Power Watts	Sens. 1W/1m db	Cost Per Unit
<b>EXCEL Premium Tweeters</b>				Voice Coils						
T25CF 001 (E0006)	25mm Sonotex fabric dome tweeter with chamber	6	750	H9920	\$27.70	26	90	90	\$86.90	
T25CF 002 (E0011)	Millennium tweeter, 25mm Sonotex, Hexadym magnet	6	500	H9929	\$29.50	26	90	88	\$170.50	
T25C 003 (E0036)	25mm Sonotex fabric dome tweeter, chamber, no FF	6	750	H9920	\$27.70	26	90	92	\$88.90	
T29AF 001 (E0039)	29mm Alum/Magn. alloy dome tweeter with chamber	6	500	H9938	\$34.75	26	100	92	\$162.00	
T29CF 001 (E0038)	29mm Sonotex fabric dome tweeter, with chamber	6	550	H9939	\$29.95	26	90	93	\$160.15	
T29CF 002 (E0040)	Crescendo tweeter, 29mm Sonotex, Hexadym magnet	6	500	H9939	\$29.95	26	90	92.5	\$263.30	
<b>EXCEL Premium Magnesium Cone Woofers with Copper Phase Plugs (E0026 has Alum./Mag.Alloy cone)</b>										
Due to new environmental rules in Europe, Seas can no longer copper plate the back plate of the Excel woofers. The woofers will be switched over to a rubber boot, like the Nextel speakers.										
W12CY 001 (E0021)	4.5" magnesium cone woofer with copper phase plug	8	46	.32	5.8	3	26	70	85	\$133.10
W15CH 001 (E0037)	5.5" magnesium cone woofer, copper phase plug, Neo	8	41	.45	12	4	26	70	85	\$172.20
W15CY 001 (E0015)	5.5" magnesium cone woofer with copper phase plug	8	37	.34	13.5	4	26	70	86	\$135.45
W18E 001 (E0018)	7" magnesium cone woofer with copper phase plug	8	31	.34	37	5	39	100	86.5	\$158.95
W18E 001/TV (E0027)	Magnetically shielded version of W18E-001	8	29	.29	56	5	39	100	87.5	\$167.80
W18EX 001 (E0017)	Larger magnet version of W18E-001	8	31	.24	37	5	39	100	88	\$162.80
W22EX 001 (E0022)	8" magnesium cone woofer with copper phase plug	8	27	.34	75	5	39	120	90	\$177.45
W26FX 001 (E0026)	10" aluminum alloy cone with copper phase plug	8	20	.35	161	7	51	150	87	\$260.75
<b>EXCEL Premium Nextel Cone Midrange &amp; Woofers with Phase Plugs</b>										
M15CH-002 (E0043)	5" Nextel cone midrange, Neodymium magnet	6	67	.40	6	3	26	70	88.5	\$165.35
W12CY-003 (E0044)	4.5" Nextel coated paper, phase plug, wide range	8	60	.36	4	3	26	70	85.5	\$121.30
W15LY 001 (E0041)	5.5" Nextel coated paper cone woofer, phase plug	8	49	.45	12	5	26	60	86.5	\$115.10
W18NX 001 (E0042)	7" Nextel coated paper cone woofer, phase plug	8	40	.34	24	7	39	80	87.5	\$153.70
W26FX 002 (E0046)	10" Nextel coated paper cone woofer, phase plug	8	31	.39	87	7	51	100	89	\$283.15
<b>Prestige Line Tweeters</b>										
25TFFN/QG (H0625)	25mm textile dome tweeter, neodymium magnet, grill	6	1800	Voice Coils			26	90	89	\$24.40
19TFF1 (H0737)	19mm textile dome tweeter	8	1700				19.5	80	87	\$19.30
22TAF/G (H1283)	22mm aluminum/magnesium alloy dome tweeter, grill	6	1100	H9940	\$17.75	19.5	80	92	\$26.60	
27TAFNC/G (H1397)	27mm aluminum dome, neodymium magnet, grill	4	1170	Not Repairable			26	90	90	\$28.95
27TFFNC/G (H1396)	27mm textile dome, neodymium magnet, grill	4	1170	Not Repairable			26	80	91	\$28.80
27TBC/G (H1147)	27mm alum./Magnesium dome tweeter, Chmb, no FF	6	600	H9932	\$13.35	26	55	92	\$32.20	
27TBFC/G (H1212)	27mm alum./Magnesium dome tweeter, Chmb, w/ FF	6	550	H9932	\$13.35	26	90	92	\$32.80	
27TDF (H1211)	27mm coated textile dome tweeter, w/ FF	6	900	H9933	\$12.00	26	90	92	\$25.15	
27TDC (H1149)	27mm textile dome tweeter, chambered, non-FF	6	550	H9933	\$12.00	26	55	90	\$30.15	
27TDFC (H1189)	27mm textile dome tweeter, chambered, w/ FF	6	550	H9933	\$12.00	26	90	91	\$30.80	
27TDFC/TV (H1210)	Shielded 27mm textile dome tweeter, w/ FF	6	800	H9933	\$12.00	26	90	90	\$29.50	
27TFF (H0831)	27mm coated textile dome tweeter	6	1200	H9918	\$15.75	26	90	92	\$23.80	
27TFFC (H0881)	27mm coated textile dome tweeter w/chamber	6	900	H9918	\$15.75	26	80	91	\$29.40	
29TAF/W (H1322)	29mm Aluminum/Magnesium alloy dome, w/ elastomer	6	950	H9941	\$22.35	26	100	91.5	\$35.95	
29TFF/W (H1318)	29mm fabric dome, with elastomer wave guide front	6	950	H9942	\$20.10	26	90	92	\$32.30	
<b>Prestige Line Midranges</b>										
MCA12RC (H1304)	4.5" coated paper cone midrange, natural rubber surr.	8	68	.56	5	0.9	26	110	86	\$42.50
MCA15RCY (H1262)	5" coated paper cone midrange, natural rubber surr.	8	51	.25	12	1.7	26	100	90	\$51.55
<b>Prestige Line Woofers</b>										
CA12RCY (H1152)	4.5" coated paper cone woofer, raised spider	8	57	.31	5	3	26	60	86	\$46.15
L12RCY/P (H1207)	4.5" Aluminum cone woofer with phase plug	8	48	.28	6	3	26	70	86	\$50.10
CA15RLY (H1216)	5" coated paper cone mid/woofer	8	47	.37	12	5	26	60	87	\$50.70
L15RLY/P (H1141)	5" aluminum cone woofer, phase plug, raised spider	8	46	.37	12	5	26	80	86	\$56.05
CA18RLY (H1217)	6.5" coated paper cone woofer for sealed boxes	8	40	.45	30	5	26	80	88	\$49.35



Model	Size Description	$\Omega$	Fs Hz	Qts	Vas Liters	X-max mm Peak	VC $\varnothing$ mm	Power Watts	Sens. 1W/1m db	Cost Per Unit
CA18RNX (H1215)	7" coated paper cone woofer, raised spider	8	36	.35	36	6	39	80	88	\$58.65
L18RNX/P (H1224)	7" aluminum cone woofer, phase plug, raised spider	8	33	.34	35	6	39	100	87	\$69.30
P18RNX/P (H1350)	7" Polypropylene cone woofer, phase plug, raised spider	8	43	.33	25	6	39	80	89	\$62.65
CA22RNX (H1288)	8" coated paper cone woofer, bumped back plate	8	29	.41	97	6	39	80	89.5	\$63.45
L22RN4X/P (H1208)	8" alum. cone woofer, raised spider, bumped, 4 layer	8	23	.32	72	7	39	125	86	\$73.85
L22RNX/P (H1252)	8" aluminum cone woofer, raised spider, bumped BP	8	23	.33	116	6	39	110	88	\$68.15
CA26RFX (H1305)	10" coated paper cone, raised spider, bumped back	8	29	.34	129	7	51	100	90.5	\$117.80
CA26RE4X (H1316)	10" coated paper cone, raised spider, 4 layer voice coil	8	25	.28	164	4	39	80	91	\$86.40
L26RFX/P (H1209)	10" Aluminum cone woofer, raised spider, Bumped BB	8	20	.34	166	7	51	125	87	\$119.50
<b>Passive Radiators</b>										
SP17R (H9928)	6.5" passive radiator, threaded bolt for adding weight		26		41	9.5				\$31.10
SP21R (H9901)	8" passive radiator, threaded bolt for adding weight		22		138	10				\$38.40
SP25R (H9902)	10" passive radiator, threaded bolt for adding weight		22		214	12.5				\$47.25
<b>Prestige Line Coaxial Drivers - The tweeter is mounted at the base of the woofer cone (coincidental).</b>										
T18REX/FXC (H1353)	7" coaxial, clear cone, raised spider, coincidental, new adaptive surround	T6 W8	T1.2K W29	W .22	W 47.9	W 3	T26 W39	T90 W90	T88.5 W87	\$115.00
T18RE/XFCTV2 (H1333) (Shielded)	7" coaxial, clear cone, raised spider, coincidental, new adaptive surround and shielded for use near CRT's	T6 W8	T1.2 W26	W .26	W 52	W 3	T26 W39	T90 W90	T88.5 W87	\$118.95
Seas designed crossover for the T18RE Coaxial Speakers, using 16AWG on woofer, Poly Caps on tweeter, Eagle on tweeter										\$36.50
We still have stock of many older Seas units. Please visit our web site at <a href="http://www.madisound.com">www.madisound.com</a> for information and availability on these older units. You can also get information on all new products and kits from the Seas website at <a href="http://www.seas.no">www.seas.no</a> . Their site is also a good source for information on many vintage Seas products. Although the older units have been a mainstay of the high end audio industry for decades, these new units offer distinct advantages in performance as well as sound quality. Seas is ever striving to provide the highest quality sound reproduction products for the audio industry. This employee company understands that its success is tied to the quality of its product and commitment to its customer base. These new product lines are a testament to their commitment.										

### Excel T25FC-001E0006

This 25mm dome tweeter features the proprietary SONOTEX fabric dome. SONOTEX is only manufactured by Seas and is pre-coated 4 times with a damping/sealing material, resulting in excellent acoustic performance and consistency. The T25-001 has a silver wire voice coil, tinsel leads, gold plated terminals and magnetic fluid cooling/lubricant. The T25-001 has a double magnet, one added in reverse for use in A/V systems. The complex shape chamber reduces resonance and interior reflections.



### Excel T25CF-002 E0011

The "Millennium" This 25mm dome tweeter features the proprietary SONOTEX fabric dome. You can expect extremely precise, realistic reproduction and excellent acoustic performance and consistency from the T25CF-002. Equipped with flexible lead-out wires, underhung voice coil for low distortion, tinsel leads, gold plated terminals, and Neodymium based HEXADYD magnet system. Low viscosity magnetic fluid is used for cooling and high power handling. Its low free air resonance is below that of most dome tweeters. Unique molded zinc rear chamber eliminates unwanted interior resonances.



Nominal Impedance	6 Ohms	Voice coil resistance	4.3 Ohms
Recom. frequency range	2000-25000 Hz	Voice coil inductance	0.05 mH
Short term max. power	200 W	Force factor	3.5 N/A
Long term max. power	90 W	Free air resonance	750 Hz
Sensitivity (1W/1m)	90 dB	Moving mass	0.33 g
		Suspension compliance	- mm/N
Voice Coil Diameter	26 mm	Suspension mech. resistance	- Ns/m
Voice coil height	1.5 mm	Effective piston area	7 sq. cm
Air gap height	2.0 mm	Vas	- Liters
Linear coil travel (p-p)	0.5 mm	Qms	-
Max. coil travel (p-p)	- mm	Qes	-
Magnet weight	0.34 Kg	Qts	-
Total weight	0.80 Kg		

Nominal Impedance	6 Ohms	Voice coil resistance	4.7 Ohms
Recom. frequency range	2000-25000 Hz	Voice coil inductance	0.05 mH
Short term max. power	200 W	Force factor	3.1 N/A
Long term max. power	90 W	Free air resonance	500 Hz
Sensitivity (1W/1m)	88 dB	Moving mass	0.37 g
		Suspension compliance	- mm/N
Voice Coil Diameter	26 mm	Suspension mech. resistance	- Ns/m
Voice coil height	1.5 mm	Effective piston area	7 sq. cm
Air gap height	2.5 mm	Vas	- Liters
Linear coil travel (p-p)	1.0 mm	Qms	-
Max. coil travel (p-p)	- mm	Qes	-
Magnet weight	0.29 Kg	Qts	-
Total weight	0.36 Kg		

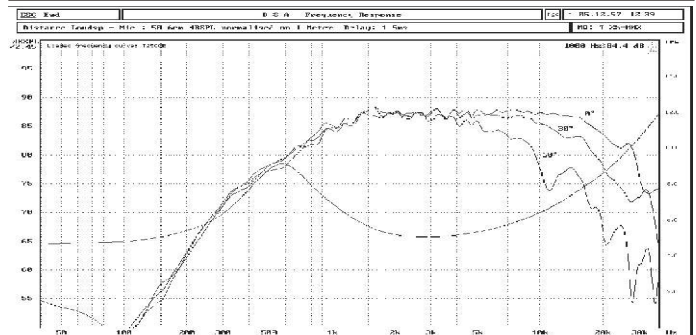
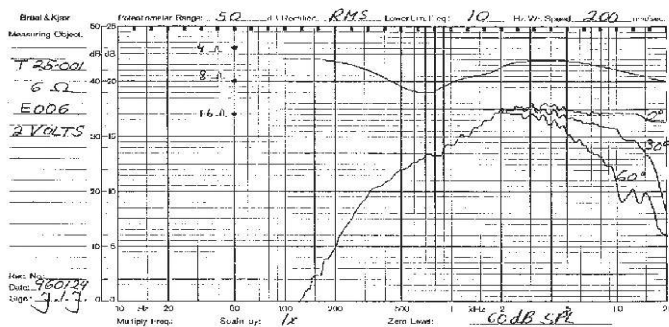

## Excel T25C-003 E0036

This 25mm dome tweeter features the proprietary SONOTEX fabric dome. SONOTEX is only manufactured by Seas and is pre-coated 4 times with a damping/sealing material, resulting in excellent acoustic performance and consistency. The T25-001 has a silver wire voice coil, tinsel leads and gold plated terminals. A wide polymer surround is used to give added stability **without magnetic fluid**. The T25C-003 has a double magnet, one added in reverse for use in A/V systems. The complex shape chamber reduces resonance and interior reflections.



Nominal Impedance	6 Ohms	Voice coil resistance	4.3 Ohms
Recom. frequency range	2000-25000 Hz	Voice coil inductance	0.05 mH
Short term max. power	200 W	Force factor	3.5 N/A
Long term max. power	90 W	Free air resonance	750 Hz
Sensitivity (1W/1m)	92 dB	Moving mass	0.33 g
		Suspension compliance	- mm/N
Voice Coil Diameter	26 mm	Suspension mech. resistance	- Ns/m
Voice coil height	1.5 mm	Effective piston area	7 sq. cm
Air gap height	2.0 mm		
Linear coil travel (p-p)	0.5 mm	Vas	- Liters
Max. coil travel (p-p)	- mm	Qms	-
Magnet weight	0.34 Kg	Qes	-
Total weight	0.80 Kg	Qts	-

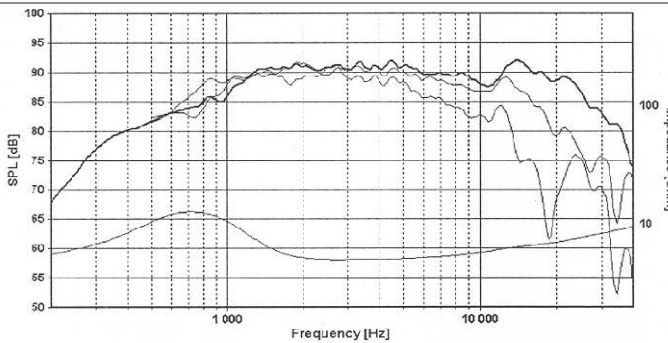

## Excel T29AF-001 E0039

The T29AF001 is a High End, High Efficiency 29mm aluminum/magnesium alloy dome tweeter. An optimally shaped dome and a wide SONOMEX surround, both manufactured by SEAS, ensure excellent performance and consistency. A powerful magnet system based on axially magnetized NdFeB ring magnets. A generously underhung voice coil with flexible lead-out wires ensures low distortion. A 6mm precision machined aluminum front plate, Nextel painted, injection molded rear chamber made from zinc eliminates unwanted chamber wall resonances



Nominal Impedance	6 Ohms	Voice coil resistance	4.7 Ohms
Recom. frequency range	2000-22000 Hz	Voice coil inductance	0.05 mH
Short term max. power	220 W	Force factor	3.9 N/A
Long term max. power	100 W	Free air resonance	500 Hz
Sensitivity (1W/1m)	92 dB	Moving mass	0.39 g
		Suspension compliance	- mm/N
Voice Coil Diameter	26 mm	Suspension mech. resistance	- Ns/m
Voice coil height	1.5 mm	Effective piston area	8 sq. cm
Air gap height	2.5 mm		
Linear coil travel (p-p)	0.5 mm	Vas	- Liters
Max. coil travel (p-p)	- mm	Qms	-
Magnet weight	0.053 Kg	Qes	-
Total weight	0.67 Kg	Qts	-

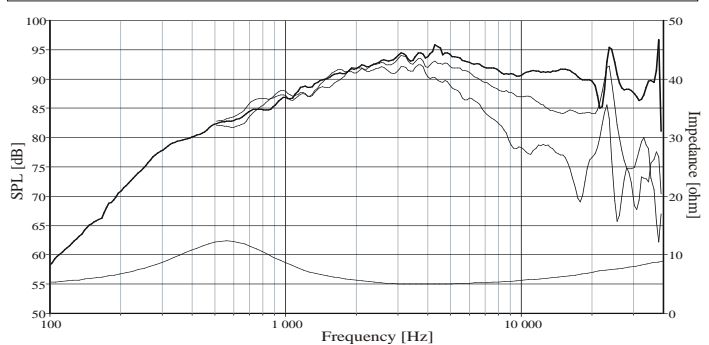

## Excel T29CF-001 E0038

The T29CF001 is a High End, High Efficiency 29mm fabric dome tweeter with a wide surround. An optimally shaped dome and a wide SONOMEX surround, both manufactured by SEAS, ensure excellent performance and consistency. A powerful magnet system based on axially magnetized NdFeB ring magnets. A generously underhung voice coil with flexible lead-out wires ensures low distortion. A 6mm precision machined aluminum front plate, Nextel painted, injection molded rear chamber made from zinc eliminates unwanted chamber wall resonances



Nominal Impedance	6 Ohms	Voice coil resistance	4.7 Ohms
Recom. frequency range	2000-25000 Hz	Voice coil inductance	0.05 mH
Short term max. power	200 W	Force factor	3.9 N/A
Long term max. power	90 W	Free air resonance	550 Hz
Sensitivity (1W/1m)	93 dB	Moving mass	0.35 g
		Suspension compliance	- mm/N
Voice Coil Diameter	26 mm	Suspension mech. resistance	- Ns/m
Voice coil height	1.5 mm	Effective piston area	8 sq. cm
Air gap height	2.5 mm		
Linear coil travel (p-p)	0.5 mm	Vas	- Liters
Max. coil travel (p-p)	- mm	Qms	-
Magnet weight	0.053 Kg	Qes	-
Total weight	0.67 Kg	Qts	-

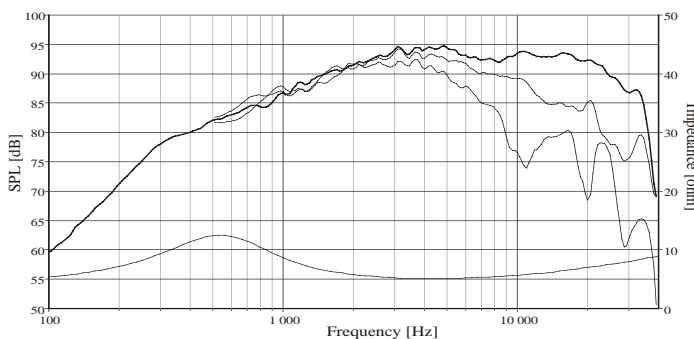

## Excel T29CF-002 E0040

The T29CF002, "CRESCENDO" is an Ultra High End 29mm soft dome tweeter. An optimally shaped dome with wide Sonomex surround. A high efficiency HEXADYM magnet system, based on 6 radially magnetized NdFeB magnet blocks, provide efficient ventilation and damping of cavities behind the dome, surround and voice coil. Inherently shielded. Generously underhung voice coil with flexible lead out wires. A 6mm precision machined aluminum front plate, Nextel painted, injection molded rear chamber made from zinc eliminates unwanted chamber wall resonances



Nominal Impedance	6 Ohms	Voice coil resistance	4.3 Ohms
Recom. frequency range	2000-25000 Hz	Voice coil inductance	0.05 mH
Short term max. power	200 W	Force factor	3.5 N/A
Long term max. power	90 W	Free air resonance	750 Hz
Sensitivity (1W/1m)	92.5 dB	Moving mass	0.33 g
		Suspension compliance	- mm/N
Voice Coil Diameter	26 mm	Suspension mech. resistance	- Ns/m
Voice coil height	1.5 mm	Effective piston area	7 sq. cm
Air gap height	2.5 mm		
Linear coil travel (p-p)	0.5 mm	Vas	- Liters
Max. coil travel (p-p)	- mm	Qms	-
Magnet weight	0.053 Kg	Qes	-
Total weight	0.66 Kg	Qts	-

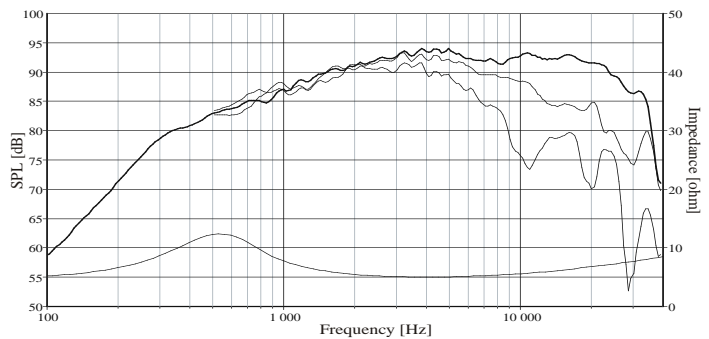



### Excel W12CY-001 E0021

This 4.5" woofer features a light, yet stiff **magnesium cone** for bass precision and midrange detail. The cone is attached to the magnesium cast frame by a natural rubber surround that shows no sign of midrange (edge) resonance. Heavy copper coils mounted above and below the T-shaped pole piece reduce non linear and intermodulation distortion. The raised spider keeps the voice coil from bottoming out and also reduces noise caused by mechanical distortion. A large magnet system is used for improved sensitivity and transient response.



Nominal Impedance	8 Ohms	Voice coil resistance	5.6 Ohms
Recom. frequency range	60-3500 Hz	Voice coil inductance	0.3 mH
Short term max. power	200 W	Force factor	5.6 N/A
Long term max. power	70 W	Free air resonance	46 Hz
Sensitivity (1W/1m)	85 dB	Moving mass	7.0 g
		Suspension compliance	1.7 mm/N
Voice Coil Diameter	26 mm	Suspension mech. resistance	1.0 Ns/m
Voice coil height	12 mm	Effective piston area	50 sq. cm
Air gap height	6.0 mm		
Linear coil travel (p-p)	6.0 mm	Vas	5.8 Liters
Max. coil travel (p-p)	9 mm	Qms	2.2
Magnet weight	0.42 Kg	Qes	0.37
Total weight	1.21 Kg	Qts	0.32

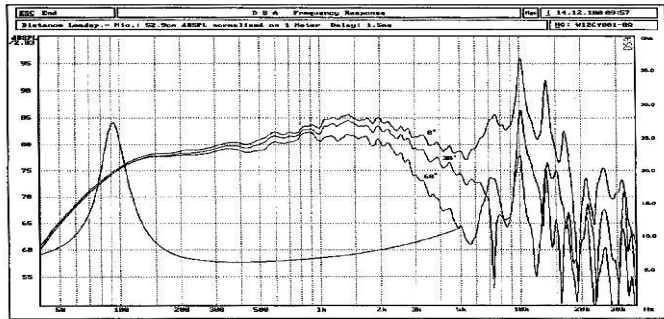

### Excel W15CH-001 E0037

The W15CH-001 is a 5" cone driver developed for use as a woofer or woofer/midrange. The extremely stiff, yet light magnesium cone delivers tremendous bass precision and midrange detail. This speaker has an acoustically transparent basket and a natural rubber surround. This woofer has the patented Hexadym magnet system, based on 6 radially magnetized Neodymium blocks. Heavy copper rings mounted above and below the T-shaped pole piece reduce non-linear and intermodulation distortion. A solid copper phase plug improves heat conduction.



Nominal Impedance	8 Ohms	Voice coil resistance	5.5 Ohms
Recom. frequency range	50-3000 Hz	Voice coil inductance	0.46 mH
Short term max. power	200 W	Force factor	5.1 N/A
Long term max. power	70 W	Free air resonance	41 Hz
Sensitivity (1W/1m)	85 dB	Moving mass	9.25 g
		Suspension compliance	1.6 mm/N
Voice Coil Diameter	26 mm	Suspension mech. resistance	0.83 Ns/m
Voice coil height	14 mm	Effective piston area	75 sq. cm
Air gap height	6.0 mm		
Linear coil travel (p-p)	8.0 mm	Vas	12 Liters
Max. coil travel (p-p)	14 mm	Qms	3.00
Magnet weight	0.06 Kg	Qes	0.52
Total weight	0.80 Kg	Qts	0.45

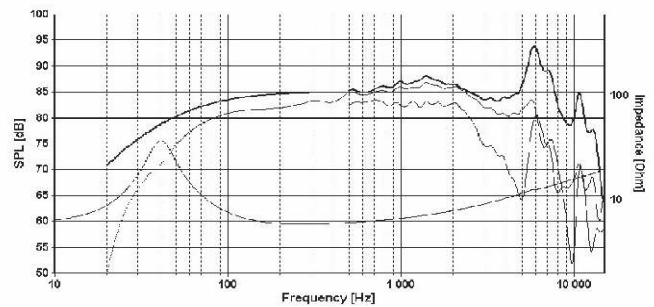

### Excel W15CY-001 E0015

This 5" woofer features a light, yet stiff **magnesium cone** for bass precision and midrange detail. The cone is attached to the magnesium cast frame by a natural rubber surround that shows no sign of midrange (edge) resonance. Heavy copper coils mounted above and below the T-shaped pole piece reduce non linear and intermodulation distortion. The raised spider keeps the voice coil from bottoming out and also reduces noise caused by mechanical distortion. A large magnet system is used for improved sensitivity and transient response.



Nominal Impedance	8 Ohms	Voice coil resistance	5.5 Ohms
Recom. frequency range	50-3000 Hz	Voice coil inductance	0.37 mH
Short term max. power	200 W	Force factor	5.8 N/A
Long term max. power	70 W	Free air resonance	37 Hz
Sensitivity (1W/1m)	86 dB	Moving mass	10.0 g
		Suspension compliance	1.7 mm/N
Voice Coil Diameter	26 mm	Suspension mech. resistance	1.5 Ns/m
Voice coil height	14 mm	Effective piston area	75 sq. cm
Air gap height	6.0 mm		
Linear coil travel (p-p)	8.0 mm	Vas	13.5 Liters
Max. coil travel (p-p)	14 mm	Qms	2.10
Magnet weight	0.42 Kg	Qes	0.40
Total weight	1.35 Kg	Qts	0.34

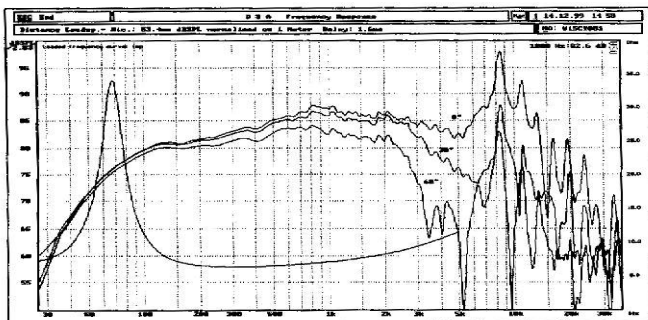

### Excel W18E-001 E0018

This 7" woofer features a light, yet stiff **magnesium cone** for bass precision and midrange detail. The cone is attached to the magnesium cast frame by a natural rubber surround that shows no sign of midrange (edge) resonance. Heavy copper coils mounted above and below the T-shaped pole piece reduce non linear and intermodulation distortion. The raised spider keeps the voice coil from bottoming out and also reduces noise caused by mechanical distortion. A large magnet system is used for improved sensitivity and transient response.



Nominal Impedance	8 Ohms	Voice coil resistance	6.1 Ohms
Recom. frequency range	40-2500 Hz	Voice coil inductance	0.4 mH
Short term max. power	250 W	Force factor	7.2 N/A
Long term max. power	100 W	Free air resonance	31 Hz
Sensitivity (1W/1m)	86.5 dB	Moving mass	15.5 g
		Suspension compliance	1.6 mm/N
Voice Coil Diameter	39 mm	Suspension mech. resistance	1.4 Ns/m
Voice coil height	16 mm	Effective piston area	126 sq. cm
Air gap height	6.0 mm		
Linear coil travel (p-p)	10.0 mm	Vas	37 Liters
Max. coil travel (p-p)	19 mm	Qms	2.50
Magnet weight	0.42 Kg	Qes	0.39
Total weight	1.75 Kg	Qts	0.34

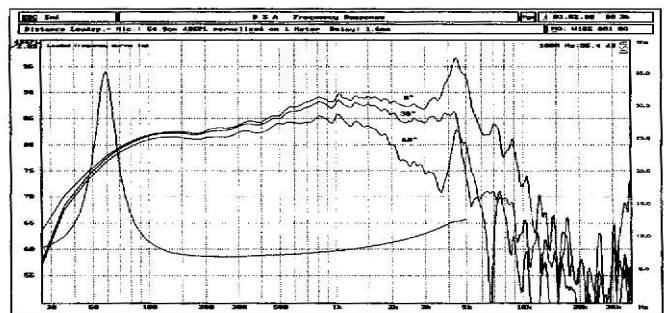



### Excel W18E-001/TV E0027

This **shielded magnet 7" woofer** features a light, yet stiff **magnesium cone** for bass precision and midrange detail. The cone is attached to the magnesium cast frame by a natural rubber surround that shows no sign of midrange (edge) resonance. Heavy copper coils mounted above and below the T-shaped pole piece reduce non linear and intermodulation distortion. The raised spider keeps the voice coil from bottoming out and also reduces noise caused by mechanical distortion. This speaker has been optimized for use in home theater systems or used near CRT's.



Nominal Impedance	8 Ohms	Voice coil resistance	5.9 Ohms
Recom. frequency range	40-2500 Hz	Voice coil inductance	0.4 mH
Short term max. power	250 W	Force factor	7.2 N/A
Long term max. power	100 W	Free air resonance	29 Hz
Sensitivity (1W/1m)	86.5 dB	Moving mass	14.4 g
Voice Coil Diameter	39 mm	Suspension compliance	2.1 mm/N
Voice coil height	16 mm	Suspension mech. resistance	1.4 Ns/m
Air gap height	6.0 mm	Effective piston area	126 sq. cm
Linear coil travel (p-p)	10.0 mm	Vas	47 Liters
Max. coil travel (p-p)	19 mm	Qms	2.27
Magnet weight	0.42 Kg	Qes	0.33
Total weight	1.75 Kg	Qts	0.29

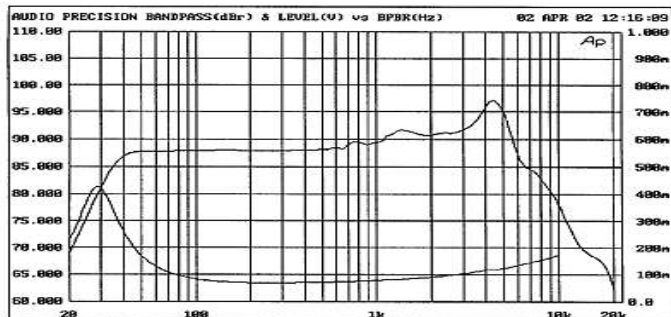

### Excel W18EX-001 E0017

This 7" woofer features a light, yet stiff **magnesium cone** for bass precision and midrange detail. The cone is attached to the magnesium cast frame by a natural rubber surround that shows no sign of midrange (edge) resonance. Heavy copper coils mounted above and below the T-shaped pole piece reduce non linear and intermodulation distortion. The raised spider keeps the voice coil from bottoming out and also reduces noise caused by mechanical distortion. A larger magnet system is used for improved sensitivity, transient response and lower Qts.



Nominal Impedance	8 Ohms	Voice coil resistance	6.1 Ohms
Recom. frequency range	40-2500 Hz	Voice coil inductance	0.4 mH
Short term max. power	250 W	Force factor	8.6 N/A
Long term max. power	100 W	Free air resonance	31 Hz
Sensitivity (1W/1m)	88 dB	Moving mass	15.5 g
Voice Coil Diameter	39 mm	Suspension compliance	1.6 mm/N
Voice coil height	16 mm	Suspension mech. resistance	1.7 Ns/m
Air gap height	6.0 mm	Effective piston area	126 sq. cm
Linear coil travel (p-p)	10.0 mm	Vas	37 Liters
Max. coil travel (p-p)	19 mm	Qms	2.0
Magnet weight	0.64 Kg	Qes	0.27
Total weight	2.15 Kg	Qts	0.24

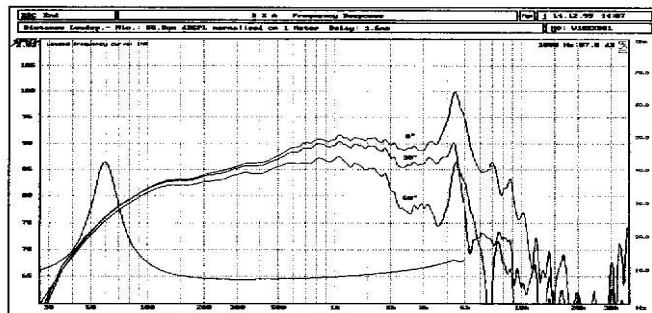

### Excel W22EX-001 E0022

This 8" woofer features a light, yet stiff **magnesium cone** for bass precision and midrange detail. The cone is attached to the magnesium cast frame by a natural rubber surround that shows no sign of midrange (edge) resonance. Heavy copper coils mounted above and below the T-shaped pole piece reduce non linear and intermodulation distortion. The raised spider keeps the voice coil from bottoming out and also reduces noise caused by mechanical distortion. A larger magnet system is used for improved sensitivity, transient response and lower Qts.



Nominal Impedance	8 Ohms	Voice coil resistance	6.0 Ohms
Recom. frequency range	30-2000 Hz	Voice coil inductance	0.5 mH
Short term max. power	300 W	Force factor	9.0 N/A
Long term max. power	120 W	Free air resonance	27 Hz
Sensitivity (1W/1m)	90.5 dB	Moving mass	29.0 g
Voice Coil Diameter	39 mm	Suspension compliance	1.1 mm/N
Voice coil height	16 mm	Suspension mech. resistance	2.0 Ns/m
Air gap height	6.0 mm	Effective piston area	220 sq. cm
Linear coil travel (p-p)	10.0 mm	Vas	75 Liters
Max. coil travel (p-p)	21 mm	Qms	2.6
Magnet weight	0.64 Kg	Qes	0.39
Total weight	2.2 Kg	Qts	0.34

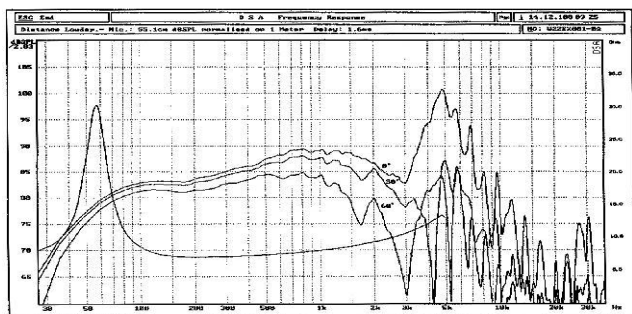

### Excel W26FX-001 E0026

This 10" woofer features a light, yet stiff **aluminum alloy cone** for stiffness in providing bass precision. Heavy copper rings mounted above and below the T-shaped pole piece reduce non linear and intermodulation distortion and increase overload margin. The raised spider keeps the voice coil from bottoming out and also reduces noise caused by mechanical distortion. Power handling is improved by using a high temperature 2" voice coil and by the solid copper phase plug conducting heat away from the voice coil. Optimized for ported enclosures.



Nominal Impedance	8 Ohms	Voice coil resistance	6.3 Ohms
Recom. frequency range	20-1000 Hz	Voice coil inductance	1.43 mH
Short term max. power	400 W	Force factor	10.7 N/A
Long term max. power	150 W	Free air resonance	20 Hz
Sensitivity (1W/1m)	87.0 dB	Moving mass	56.3 g
Voice Coil Diameter	51 mm	Suspension compliance	1.1 mm/N
Voice coil height	20 mm	Suspension mech. resistance	3.3 Ns/m
Air gap height	6.0 mm	Effective piston area	330 sq. cm
Linear coil travel (p-p)	14.0 mm	Vas	161 Liters
Max. coil travel (p-p)	35 mm	Qms	2.28
Magnet weight	3.0 Kg	Qes	0.41
Total weight	4.5 Kg	Qts	0.35

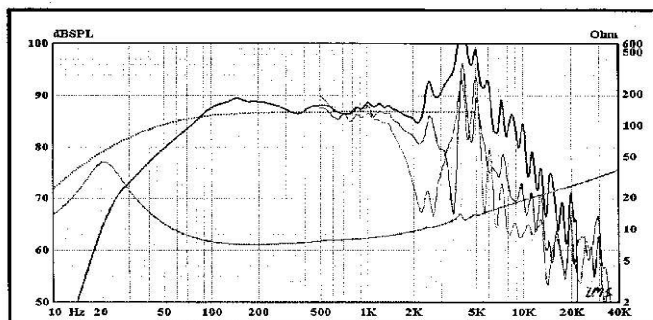

### Excel/ M15CH-002 E0043

The M15CH-002 is a 5" Nextel coated paper cone midrange, capable of the most neutral and transparent sound reproduction. The low distortion and low mechanical noise generated by this driver set a new standard for midrange units. The Hexadym magnet system is designed to keep cavity resonances and sound reflection to a minimum. Copper rings are employed to reduce non-linear and modulation distortion. A solid copper phase plug enhances the performance of the voice coil. The cast frame with large windows is designed for quiet operation and air flow.



Nominal Impedance	6 Ohms	Voice coil resistance	4.9 Ohms
Recom. frequency range	60-3500 Hz	Voice coil inductance	0.43 mH
Short term max. power	200 W	Force factor	5.3 N/A
Long term max. power	70 W	Free air resonance	67 Hz
Sensitivity (1W/1m)	88.5 dB	Moving mass	6.75 g
		Suspension compliance	0.8 mm/N
Voice Coil Diameter	26 mm	Suspension mech. resistance	1.77 Ns/m
Voice coil height	12 mm	Effective piston area	75 sq. cm
Air gap height	6 mm		
Linear coil travel (p-p)	6 mm	Vas	6.0 Liters
Max. coil travel (p-p)	14 mm	Qms	1.70
Magnet weight (Neodymium)	0.06 Kg	Qes	0.52
Total weight	0.8 Kg	Qts	0.40

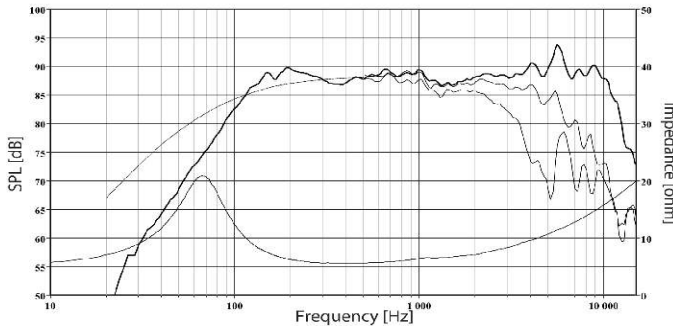

### Excel/ W12CY-003 E0044

The W12CY-003 is a 4.5" paper cone with a unique Nextel coating, for smooth response and low distortion. The new Adaptive Surround provides greater damping in the upper frequencies and less damping for bass frequencies. A large magnet and copper clad aluminum voice coil provide good excursion, low distortion and good transient response. Heavy copper rings mounted above and below the T-shaped pole pieces reduce non-linear and intermodulation distortion. Large windows in the cast basket, above and below the voice coil reduce air flow noise and ventilate the voice coil.



Nominal Impedance	8 Ohms	Voice coil resistance	5.5 Ohms
Recom. frequency range	60-3500 Hz	Voice coil inductance	0.41 mH
Short term max. power	200 W	Force factor	5.5 N/A
Long term max. power	70 W	Free air resonance	60 Hz
Sensitivity (1W/1m)	85.5 dB	Moving mass	6.1 g
		Suspension compliance	1.2 mm/N
Voice Coil Diameter	26 mm	Suspension mech. resistance	1.03 Ns/m
Voice coil height	12 mm	Effective piston area	50 sq. cm
Air gap height	6 mm		
Linear coil travel (p-p)	6 mm	Vas	4.0 Liters
Max. coil travel (p-p)	9 mm	Qms	2.30
Magnet weight	0.42 Kg	Qes	0.44
Total weight	1.3 Kg	Qts	0.36

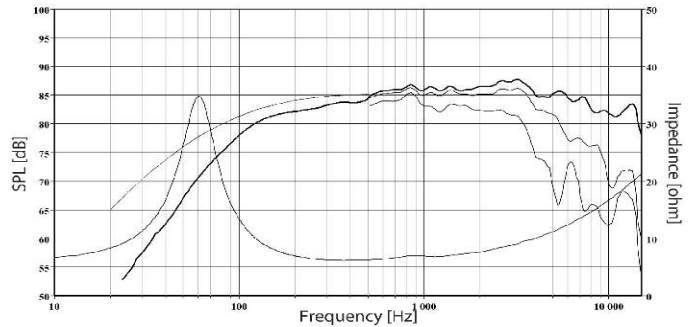

### Excel/ W15LY-001 E0041

The W15LY-001 is a paper cone with a unique Nextel coating, for smooth response and low distortion. The new Adaptive Surround provides greater damping in the upper frequencies and less damping for bass frequencies. A large magnet and copper clad aluminum voice coil provide good excursion, low distortion and good transient response. Heavy copper rings mounted above and below the T-shaped pole pieces reduce non-linear and intermodulation distortion. Large windows in the cast basket, above and below the voice coil reduce air flow noise and ventilate the voice coil.



Nominal Impedance	8 Ohms	Voice coil resistance	5.7 Ohms
Recom. frequency range	50-4000 Hz	Voice coil inductance	0.3 mH
Short term max. power	250 W	Force factor	4.6 N/A
Long term max. power	60 W	Free air resonance	49 Hz
Sensitivity (1W/1m)	86.5 dB	Moving mass	6.28 g
		Suspension compliance	1.7 mm/N
Voice Coil Diameter	26 mm	Suspension mech. resistance	0.93 Ns/m
Voice coil height	16 mm	Effective piston area	75 sq. cm
Air gap height	6 mm		
Linear coil travel (p-p)	10 mm	Vas	12.0 Liters
Max. coil travel (p-p)	20 mm	Qms	2.21
Magnet weight	0.42 Kg	Qes	0.56
Total weight	1.29 Kg	Qts	0.45

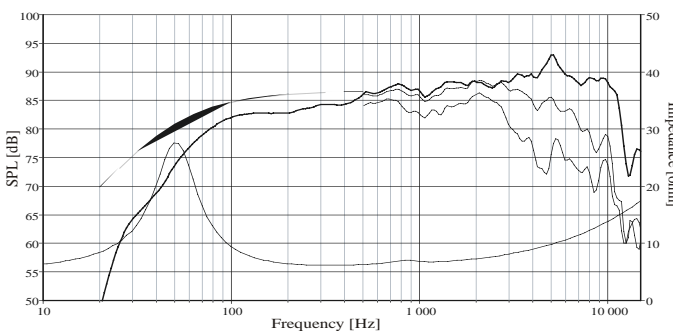

### Excel/ W18NX-001 E0042

The W18NX-001 is a paper cone with a unique Nextel coating, for smooth response and low distortion. The new Adaptive Surround provides greater damping in the upper frequencies and less damping for bass frequencies. A large magnet and copper clad aluminum voice coil provide good excursion, low distortion and good transient response. Heavy copper rings mounted above and below the T-shaped pole pieces reduce non-linear and intermodulation distortion. Large windows in the cast basket, above and below the voice coil reduce air flow noise and ventilate the voice coil.



Nominal Impedance	8 Ohms	Voice coil resistance	6.3 Ohms
Recom. frequency range	30-3000 Hz	Voice coil inductance	0.43 mH
Short term max. power	250 W	Force factor	7.0 N/A
Long term max. power	80 W	Free air resonance	40 Hz
Sensitivity (1W/1m)	87.5 dB	Moving mass	13.7 g
		Suspension compliance	1.2 mm/N
Voice Coil Diameter	39 mm	Suspension mech. resistance	1.77 Ns/m
Voice coil height	20 mm	Effective piston area	126 sq. cm
Air gap height	6 mm		
Linear coil travel (p-p)	14 mm	Vas	24 Liters
Max. coil travel (p-p)	22 mm	Qms	2.08
Magnet weight	0.64 Kg	Qes	0.41
Total weight	2.15 Kg	Qts	0.34

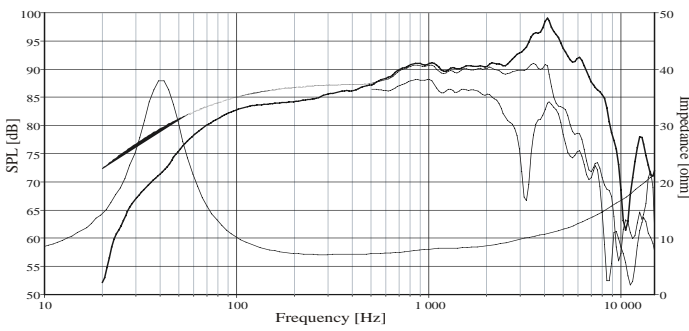



## Excel W26FX-002 E0046

The W26FX-002 is a paper cone with a unique Nextel coating to provide stiffness and reduce distortion. A 2" diameter high temperature with black anodized coil former is incorporated for high power handling and reduced power compression. Heavy copper rings mounted above and below the T-shaped pole pieces reduce non-linear and intermodulation distortion. A chrome plated brass phase plug reduces temperature variations in the voice coil and reduces cavity resonances. Large windows in the cast basket, reduce air flow noise and ventilate the voice coil.



Nominal Impedance	8 Ohms	Voice coil resistance	6.2 Ohms
Recom. frequency range	30-1000 Hz	Voice coil inductance	0.81 mH
Short term max. power	300 W	Force factor	10.9 N/A
Long term max. power	100 W	Free air resonance	31 Hz
Sensitivity (1W/1m)	89.0 dB	Moving mass	42.4 g
		Suspension compliance	0.6 mm/N
Voice Coil Diameter	51 mm	Suspension mech. resistance	3.52 Ns/m
Voice coil height	20 mm	Effective piston area	330 sq. cm
Air gap height	6 mm		
Linear coil travel (p-p)	14 mm	Vas	87 Liters
Max. coil travel (p-p)	35 mm	Qms	2.55
Magnet weight	3.00 Kg	Qes	0.47
Total weight	4.5 Kg	Qts	0.39

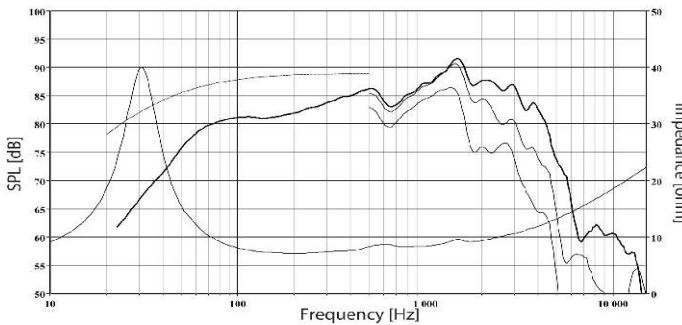

## Seas 25TFFN/QG H625

This 25mm textile dome tweeter is an ideal choice for A/V systems, automotive systems, or any application requiring a small and shallow tweeter with very little stray magnetic field. The dome is vacuum formed from a pre-coated fabric. A hexagrid grill protects the dome. The tweeter uses a neodymium magnet and magnet fluid cooling/lubricant for high power handling and simplified crossover. The flange is 60mm square (about 2.36" square) and is very shallow.



Nominal Impedance	6 Ohms	Voice coil resistance	4.8 Ohms
Recom. frequency range	3000-25000 Hz	Voice coil inductance	0.05 mH
Short term max. power	220 W	Force factor	2.45 N/A
Long term max. power	90 W	Free air resonance	1800 Hz
Sensitivity (1W/1m)	89 dB	Moving mass	0.3 g
		Suspension compliance	- mm/N
Voice Coil Diameter	26 mm	Suspension mech. resistance	- Ns/m
Voice coil height	1.5 mm	Effective piston area	7.0 sq. cm
Air gap height	2.0 mm		
Linear coil travel (p-p)	0.5 mm	Vas	- Liters
Max. coil travel (p-p)	- mm	Qms	-
Magnet weight	0.01 Kg	Qes	-
Total weight	0.10 Kg	Qts	-

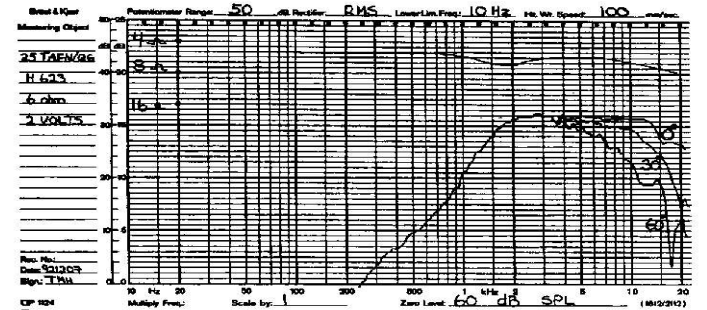

## Seas 19TFF1 H737

This 19mm textile dome tweeter offers an extremely smooth response from 4K to over 20KHz. The textile dome is made from a pre-coated fabric for very tight production tolerances. The dome is suspended by a soft polyamide surround. The frame is a glass fiber reinforced plastic. The voice coil is wound on a perforated aluminum former and immersed in magnetic fluid to reduce problems with resonance and increase short term power handling and decrease compression at high power levels.



Should be a good choice for any system requiring a tweeter above 4KHz.

Nominal Impedance	8 Ohms	Voice coil resistance	6.2 Ohms
Recom. frequency range	4000-20000 Hz	Voice coil inductance	0.05 mH
Short term max. power	200 W	Force factor	2.6 N/A
Long term max. power	80 W	Free air resonance	1700 Hz
Sensitivity (1W/1m)	87 dB	Moving mass	0.20 g
		Suspension compliance	- mm/N
Voice Coil Diameter	19.5 mm	Suspension mech. resistance	- Ns/m
Voice coil height	1.5 mm	Effective piston area	4.0 sq. cm
Air gap height	2.0 mm		
Linear coil travel (p-p)	0.5 mm	Vas	- Liters
Max. coil travel (p-p)	- mm	Qms	-
Magnet weight	0.12 Kg	Qes	-
Total weight	0.30 Kg	Qts	-

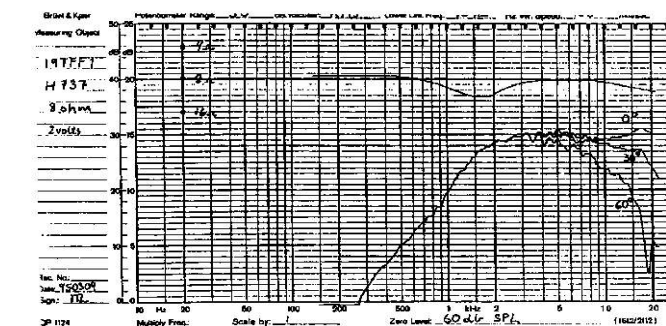

## Seas 22TAF/G H1283

The 22TAF/G is a High Definition metal dome tweeter with wide, coated fabric surround. The relatively small voice coil diameter and the wide surround combine the high frequency behavior of a 3/4" dome with the low frequency characteristics of a 1" dome. A large ferrite magnet gives high efficiency. The dome is precision formed from an aluminum/magnesium alloy for low mass and high rigidity and stability. The pre-coated surround material gives high consistency and excellent stability. The VC is ferrofluid cooled. An acoustically open Hexagrid protects the dome diaphragm.



Nominal Impedance	6 Ohms	Voice coil resistance	4.9 Ohms
Recom. frequency range	2500-30000 Hz	Voice coil inductance	0.05 mH
Short term max. power	180 W	Force factor	3.3 N/A
Long term max. power	80 W	Free air resonance	1100 Hz
Sensitivity (1W/1m)	92 dB	Moving mass	0.23 g
		Suspension compliance	- mm/N
Voice Coil Diameter	19.5 mm	Suspension mech. resistance	- Ns/m
Voice coil height	1.5 mm	Effective piston area	5.9 sq. cm
Air gap height	2 mm		
Linear coil travel (p-p)	0.5 mm	Vas	- Liters
Max. coil travel (p-p)	- mm	Qms	-
Magnet weight	0.25 Kg	Qes	-
Total weight	0.50 Kg	Qts	-

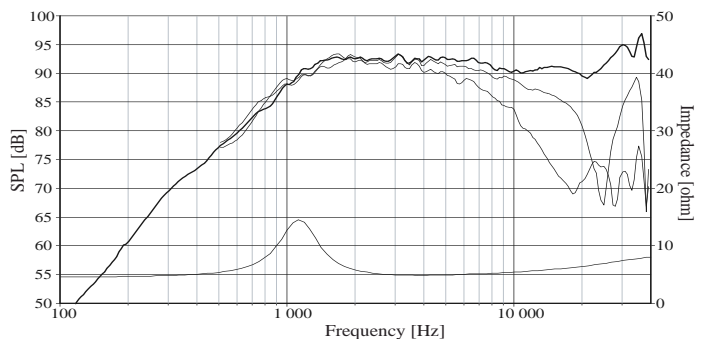



## Seas 27TAFNC/G H1397

Compact design neodymium magnet tweeter for high quality small cabinet speakers or autosound applications. Critically designed aluminum/magnesium alloy dome with good dispersion above 10kHz. A wide roll surround together with double chamber magnet system results in a low fundamental frequency. The magnet system is inherently shielded, allowing use in A/V systems. The diffusor is designed to compensate for a slight roll off towards 20kHz and also to reduce resonance above 20kHz. The voice coil is immersed in magnetic fluid. Pressure fit installation.



Nominal Impedance	4 Ohms	Voice coil resistance	2.7 Ohms
Recom. frequency range	2500-30000 Hz	Voice coil inductance	0.03 mH
Short term max. power	200 W	Force factor	1.9 N/A
Long term max. power	90 W	Free air resonance	1170 Hz
Sensitivity (1W/1m)	90 dB	Moving mass	0.30 g
		Suspension compliance	- mm/N
Voice Coil Diameter	26 mm	Suspension mech. resistance	- Ns/m
Voice coil height	1.1 mm	Effective piston area	7.5 sq. cm
Air gap height	2.0 mm		
Linear coil travel (p-p)	0.9 mm	Power ratings with 12dB filter at 2500Hz	
Max. coil travel (p-p)	- mm	The aluminum dome has slightly better power handling than the textile dome, because the aluminum helps conduct heat away from the VC.	
Magnet weight	0.01 Kg		
Total weight	0.1 Kg		

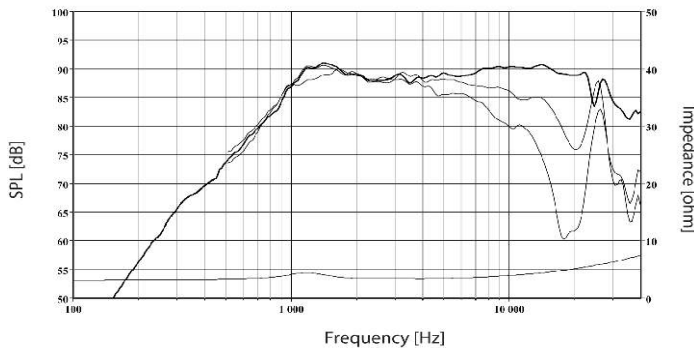

## Seas 27TFNC/G H1396

Compact design neodymium magnet tweeter for high quality small cabinet speakers or autosound applications. The diaphragm is vacuum formed from a precoated fabric for greater consistency. The coating has been carefully selected to result in a smooth frequency response and a high degree of stability against changes in temperature and humidity. A wide roll surround together with double chamber magnet system results in a low fundamental frequency. The magnet system is inherently shielded, allowing use in A/V systems. The voice coil is immersed in magnetic fluid. Pressure fit installation.



Nominal Impedance	4 Ohms	Voice coil resistance	2.7 Ohms
Recom. frequency range	2500-30000 Hz	Voice coil inductance	0.03 mH
Short term max. power	200 W	Force factor	1.9 N/A
Long term max. power	80 W	Free air resonance	1170 Hz
Sensitivity (1W/1m)	91 dB	Moving mass	0.26 g
		Suspension compliance	- mm/N
Voice Coil Diameter	26 mm	Suspension mech. resistance	- Ns/m
Voice coil height	1.1 mm	Effective piston area	7.5 sq. cm
Air gap height	2.0 mm		
Linear coil travel (p-p)	0.9 mm	Power ratings with 12dB filter @ 2500Hz	
Max. coil travel (p-p)	- mm		
Magnet weight	0.01 Kg		
Total weight	0.1 Kg		

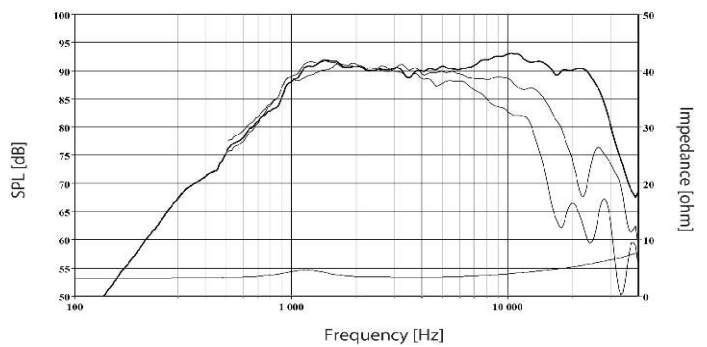

## Seas 27TBC/G H1147

The H1147 is an aluminum / magnesium alloy dome tweeter with a wide soft polymer surround, designed to give stability without using ferro fluid. The dome is protected by a hexagrid grill, which also supports an acoustic lens which tailors the high frequency roll off. The voice coil is wound on a perforated aluminum former in order to reduce air flow noise. A stiff and stable rear chamber allows for a lower resonance frequency and lower crossover point. The face plate is made from glass fiber reinforced plastic.



Nominal Impedance	6 Ohms	Voice coil resistance	4.8 Ohms
Recom. frequency range	2000-25000 Hz	Voice coil inductance	0.05 mH
Short term max. power	150 W	Force factor	3.5 N/A
Long term max. power	55 W	Free air resonance	600 Hz
Sensitivity (1W/1m)	92 dB	Moving mass	0.33 g
		Suspension compliance	- mm/N
Voice Coil Diameter	26 mm	Suspension mech. resistance	- Ns/m
Voice coil height	1.5 mm	Effective piston area	7.0 sq. cm
Air gap height	2.0 mm		
Linear coil travel (p-p)	0.5 mm	Vas	- Liters
Max. coil travel (p-p)	- mm	Qms	-
Magnet weight	0.25 Kg	Qes	-
Total weight	0.52 Kg	Qts	-

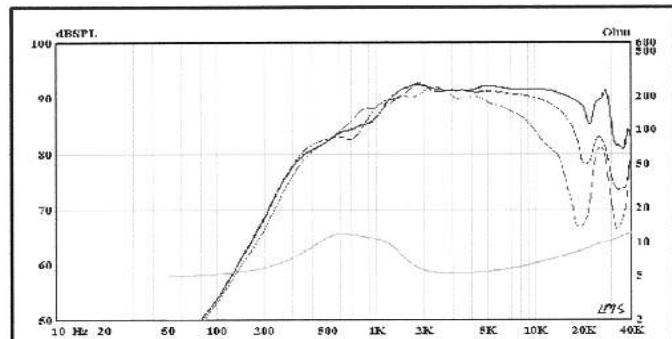

## Seas 27TBFC/G H1212

The H1212 is an aluminum / magnesium alloy dome tweeter. The special wide and soft polymer surround, initially designed to give stability without using ferro fluid, adding ferro fluid has also produced a desirable result. The dome is protected by a hexagrid metal grill, which also supports an acoustic lens to control the roll off frequencies. The voice coil is wound on a perforated aluminum former to help reduce air flow noise. The flange is made from glass fiber reinforced plastic.



Nominal Impedance	6 Ohms	Voice coil resistance	4.8 Ohms
Recom. frequency range	1500-20000 Hz	Voice coil inductance	0.05 mH
Short term max. power	220 W	Force factor	3.5 N/A
Long term max. power	90 W	Free air resonance	550 Hz
Sensitivity (1W/1m)	92 dB	Moving mass	0.34 g
		Suspension compliance	- mm/N
Voice Coil Diameter	26 mm	Suspension mech. resistance	- Ns/m
Voice coil height	1.5 mm	Effective piston area	7.0 sq. cm
Air gap height	2.0 mm		
Linear coil travel (p-p)	0.5 mm	Vas	- Liters
Max. coil travel (p-p)	- mm	Qms	-
Magnet weight	0.25 Kg	Qes	-
Total weight	0.5 Kg	Qts	-

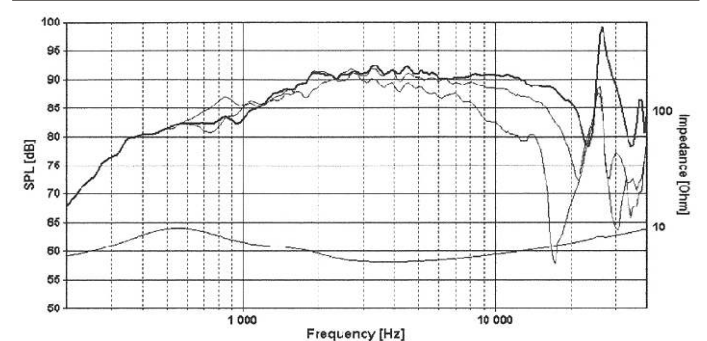

## Seas 27TDF H1211

The 27TDF is a low viscosity ferrofluid cooled tweeter with a High Definition pre-coated fabric dome and special wide soft polymer surround. The dome and surround materials give excellent stability against variations in air humidity. The voice coil is wound on an aluminum former with adequate ventilating holes to eliminate air flow noise. The chassis is precision molded glass reinforced plastic and offers optimum radiation.



Nominal Impedance	6 Ohms	Voice coil resistance	4.8 Ohms
Recom. frequency range	2500-25000 Hz	Voice coil inductance	0.05 mH
Short term max. power	200 W	Force factor	3.5 N/A
Long term max. power	90 W	Free air resonance	900 Hz
Sensitivity (1W/1m)	92 dB	Moving mass	0.37 g
		Suspension compliance	- mm/N
Voice Coil Diameter	26 mm	Suspension mech. resistance	- Ns/m
Voice coil height	1.5 mm	Effective piston area	7.5 sq. cm
Air gap height	2.0 mm		
Linear coil travel (p-p)	0.5 mm	Vas	- Liters
Max. coil travel (p-p)	- mm	Qms	-
Magnet weight	0.25 Kg	Qes	-
Total weight	0.50 Kg	Qts	-

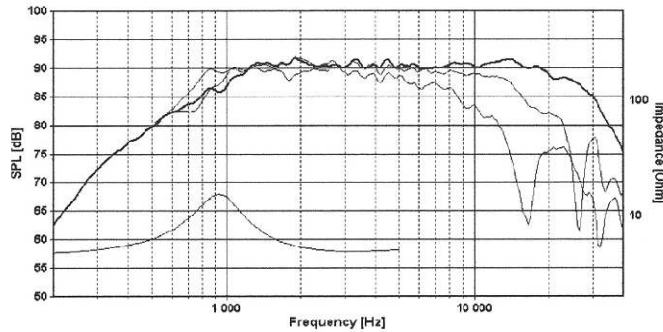

## Seas 27TDC H1149

The 27TDC is a non-ferrofluid tweeter with a High Definition pre-coated fabric dome and soft polymer surround. This tweeter has been especially designed to operate without ferrofluid. The dome and surround materials give excellent stability against variations in air humidity. The voice coil is wound on an aluminum former with adequate ventilating holes to eliminate air flow noise. A stiff and stable rear chamber with optimal acoustic damping allows the 27TDC to be used with moderately low crossover frequencies. The chassis is precision molded glass reinforced plastic and offers optimum radiation.



Nominal Impedance	6 Ohms	Voice coil resistance	4.8 Ohms
Recom. frequency range	2000-25000 Hz	Voice coil inductance	0.05 mH
Short term max. power	150 W	Force factor	3.5 N/A
Long term max. power	55 W	Free air resonance	550 Hz
Sensitivity (1W/1m)	90 dB	Moving mass	0.30 g
		Suspension compliance	- mm/N
Voice Coil Diameter	26 mm	Suspension mech. resistance	- Ns/m
Voice coil height	1.5 mm	Effective piston area	7.0 sq. cm
Air gap height	2.0 mm		
Linear coil travel (p-p)	0.5 mm	Vas	- Liters
Max. coil travel (p-p)	- mm	Qms	-
Magnet weight	0.25 Kg	Qes	-
Total weight	0.50 Kg	Qts	-

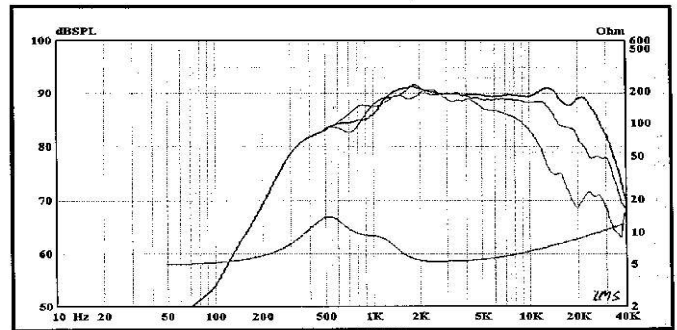

## Seas 27TDFC H1189

The 27TDFC is a low viscosity ferrofluid cooled tweeter with a High Definition pre-coated fabric dome and wide soft polymer surround. The dome and surround materials give excellent stability against variations in air humidity. The voice coil is wound on an aluminum former with adequate ventilating holes to eliminate air flow noise. A stiff and stable rear chamber with optimal acoustic damping allows the 27TDFC to be used with moderately low crossover frequencies. The chassis is precision molded glass reinforced plastic and offers optimum radiation.



Nominal Impedance	6 Ohms	Voice coil resistance	4.8 Ohms
Recom. frequency range	1500-25000 Hz	Voice coil inductance	0.05 mH
Short term max. power	220 W	Force factor	3.5 N/A
Long term max. power	90 W	Free air resonance	550 Hz
Sensitivity (1W/1m)	91 dB	Moving mass	0.37 g
		Suspension compliance	- mm/N
Voice Coil Diameter	26 mm	Suspension mech. resistance	- Ns/m
Voice coil height	1.5 mm	Effective piston area	7.5 sq. cm
Air gap height	2.0 mm		
Linear coil travel (p-p)	0.5 mm	Vas	- Liters
Max. coil travel (p-p)	- mm	Qms	-
Magnet weight	0.25 Kg	Qes	-
Total weight	0.50 Kg	Qts	-

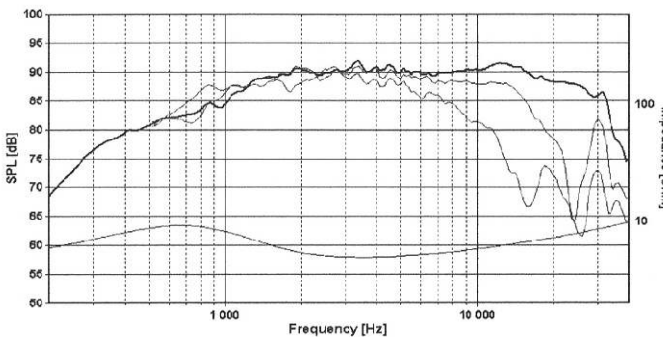

## Seas 27TDFC/TV H1210

The 27TDFC/TV is a low viscosity ferrofluid cooled tweeter with a High Definition pre-coated fabric dome and soft polymer surround. The dome and surround materials give excellent stability against variations in air humidity. The voice coil is wound on an aluminum former with ventilating holes to eliminate air flow noise. The shielded magnet system allows the tweeter to be used in proximity to video display screens or TV sets. The chassis is precision molded glass reinforced plastic and offers optimum radiation.



Nominal Impedance	6 Ohms	Voice coil resistance	4.8 Ohms
Recom. frequency range	2000-25000 Hz	Voice coil inductance	0.05 mH
Short term max. power	220 W	Force factor	2.8 N/A
Long term max. power	90 W	Free air resonance	800 Hz
Sensitivity (1W/1m)	90 dB	Moving mass	0.37 g
		Suspension compliance	- mm/N
Voice Coil Diameter	26 mm	Suspension mech. resistance	- Ns/m
Voice coil height	1.5 mm	Effective piston area	7.5 sq. cm
Air gap height	2.0 mm		
Linear coil travel (p-p)	0.5 mm	Vas	- Liters
Max. coil travel (p-p)	- mm	Qms	-
Magnet weight	0.4 Kg	Qes	-
Total weight	0.5 Kg	Qts	-

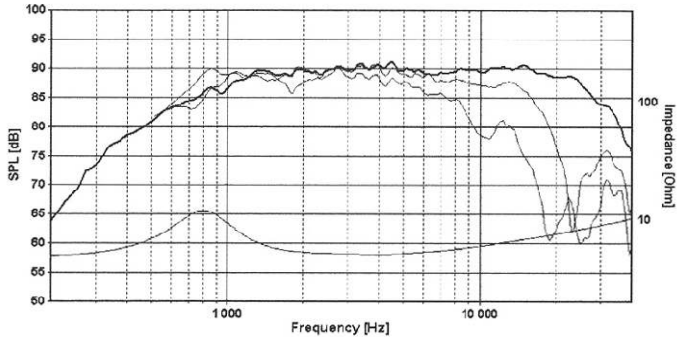



## Seas 27TFF H831

This new 27mm dome tweeter features a pre-coated textile dome for high consistency. The flange is constructed of glass fiber reinforced plastic. The voice coil is wound on an aluminum voice coil former with ventilating holes which eliminate problems connected with resonance in the internal cavities. The tweeter voice coil is immersed in magnetic fluid to increase power handling and reduce compression at high power levels. A well in the pole piece creates a small chamber for a reduced resonance frequency. Recommended for frequencies above 2500Hz. Very smooth response.

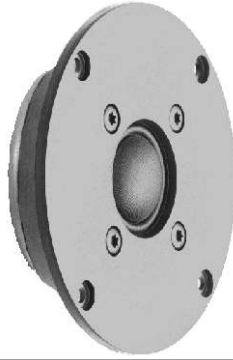

Nominal Impedance	6 Ohms	Voice coil resistance	4.8 Ohms
Recom. frequency range	2000-25000 Hz	Voice coil inductance	0.05 mH
Short term max. power	220 W	Force factor	3.5 N/A
Long term max. power	90 W	Free air resonance	1200 Hz
Sensitivity (1W/1m)	92 dB	Moving mass	.30 g
		Suspension compliance	- mm/N
Voice Coil Diameter	26 mm	Suspension mech. resistance	- Ns/m
Voice coil height	1.5 mm	Effective piston area	7.5 sq. cm
Air gap height	2.0 mm		
Linear coil travel (p-p)	0.5 mm	Vas	- Liters
Max. coil travel (p-p)	- mm	Qms	-
Magnet weight	0.25 Kg	Qes	-
Total weight	0.50 Kg	Qts	-

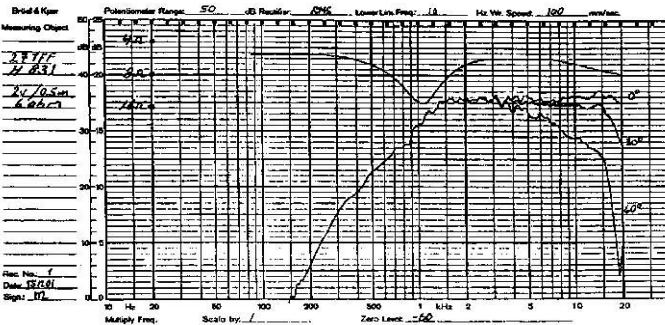

## Seas 27TFFC H881

This 27mm dome tweeter has a glass fiber reinforced plastic chassis. The diaphragm and integral surround are vacuum formed from a pre-coated fabric called Sonotex. Careful matching of the fabric and coating results in a very smooth frequency response throughout the audible range and gives a very high degree of stability against changes in air temperature and humidity. The voice coil is wound on a perforated former and is immersed in magnetic fluid. A damped hole in the pole piece and a tuned chamber behind the magnet result in a low resonance frequency.



Nominal Impedance	6 Ohms	Voice coil resistance	4.8 Ohms
Recom. frequency range	2000-30000 Hz	Voice coil inductance	0.05 mH
Short term max. power	200 W	Force factor	3.5 N/A
Long term max. power	80 W	Free air resonance	900 Hz
Sensitivity (1W/1m)	91 dB	Moving mass	0.25 g
		Suspension compliance	- mm/N
Voice Coil Diameter	26 mm	Suspension mech. resistance	- Ns/m
Voice coil height	1.5 mm	Effective piston area	7.6 sq. cm
Air gap height	2.0 mm		
Linear coil travel (p-p)	0.5 mm	Vas	- Liters
Max. coil travel (p-p)	- mm	Qms	-
Magnet weight	0.25 Kg	Qes	-
Total weight	0.52 Kg	Qts	-

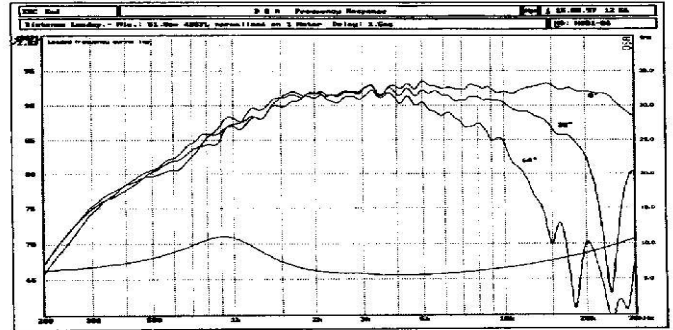

## Seas 29TAF/W H1322

The 29TAF/W aluminum/magnesium alloy dome tweeter with wide, pre-coated fabric surround. The dome and surround are made in house for excellent consistency. The voice coil is wound on an aluminum former with adequate venting holes to eliminate noise from internal air flow. Low viscosity magnetic fluid and flexible lead-out wires ensure high power handling. Two part front plate with smooth, slightly elliptical wave guide made from elastomer provide excellent high frequency response and dispersion. The wave guide conceals the magnet system screws.



Nominal Impedance	6 Ohms	Voice coil resistance	4.7 Ohms
Recom. frequency range	2200-25000 Hz	Voice coil inductance	0.05 mH
Short term max. power	220 W	Force factor	3.5 N/A
Long term max. power	100 W	Free air resonance	950 Hz
Sensitivity (1W/1m)	91.5 dB	Moving mass	0.39 g
		Suspension compliance	- mm/N
Voice Coil Diameter	26 mm	Suspension mech. resistance	- Ns/m
Voice coil height	1.5 mm	Effective piston area	8 sq. cm
Air gap height	2.0 mm		
Linear coil travel (p-p)	0.5 mm	Vas	- Liters
Max. coil travel (p-p)	- mm	Qms	-
Magnet weight	0.25 Kg	Qes	-
Total weight	0.53 Kg	Qts	-

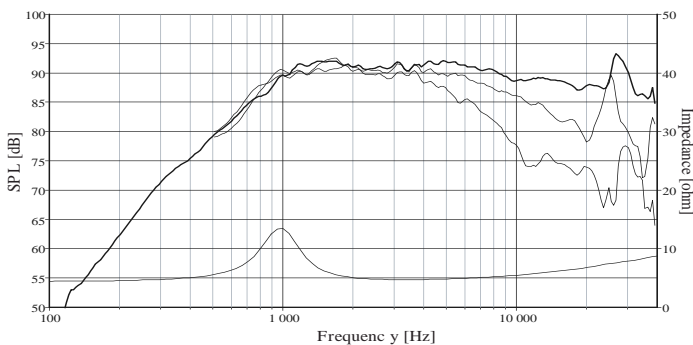

## Seas 29TFF/W H1318

The 29TFF/W is a High Definition fabric dome tweeter with integrated wide surround. The diaphragm is made in house from pre-coated fabric for consistency. The voice coil is wound on an aluminum former with adequate venting holes to eliminate noise from internal air flow. Low viscosity magnetic fluid and flexible lead-out wires ensure high power handling. Two part front plate with smooth, slightly elliptical wave guide made from elastomer provide excellent high frequency response and dispersion. The wave guide conceals the magnet system screws.



Nominal Impedance	6 Ohms	Voice coil resistance	4.7 Ohms
Recom. frequency range	2200-25000 Hz	Voice coil inductance	0.05 mH
Short term max. power	200 W	Force factor	3.5 N/A
Long term max. power	90 W	Free air resonance	950 Hz
Sensitivity (1W/1m)	92 dB	Moving mass	0.35 g
		Suspension compliance	- mm/N
Voice Coil Diameter	26 mm	Suspension mech. resistance	- Ns/m
Voice coil height	1.5 mm	Effective piston area	8 sq. cm
Air gap height	2.0 mm		
Linear coil travel (p-p)	0.5 mm	Vas	- Liters
Max. coil travel (p-p)	- mm	Qms	-
Magnet weight	0.25 Kg	Qes	-
Total weight	0.53 Kg	Qts	-

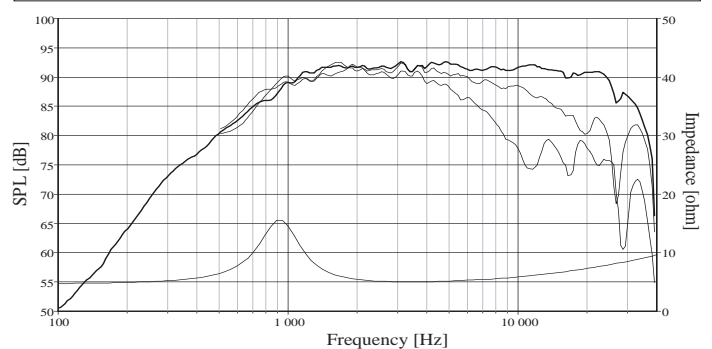



## Seas MCA12RC H1304

The MCA12RC is a 4.5" coated paper cone midrange with a mechanically matching natural rubber surround. The result is an unusually smooth midrange response. The stiff injection molded basket has large windows and a raised spider to reduce sound reflection and air flow noise. A 1" high temperature voice coil wound on an aluminum former ensured high power handling capacity.

The frequency response extends to 10,000 Hz, indicating this driver is not overly damped and will have good upper midrange response.



Nominal Impedance	8 Ohms	Voice coil resistance	6.3 Ohms
Recom. frequency range	400-5000 Hz	Voice coil inductance	0.31 mH
Short term max. power	400 W	Force factor	4.2 N/A
Long term max. power	110 W	Free air resonance	68 Hz
Sensitivity (1W/1m)	86 dB	Moving mass	5.58 g
		Suspension compliance	1.2 mm/N
Voice Coil Diameter	26 mm	Suspension mech. resistance	0.85 Ns/m
Voice coil height	5.8 mm	Effective piston area	55 sq. cm
Air gap height	4.0 mm	Vas	5 Liters
Linear coil travel (p-p)	1.8 mm	Qms	2.42
Max. coil travel (p-p)	- mm	Qes	0.74
Magnet weight	0.25 Kg	Qts	0.56
Total weight	0.66 Kg		

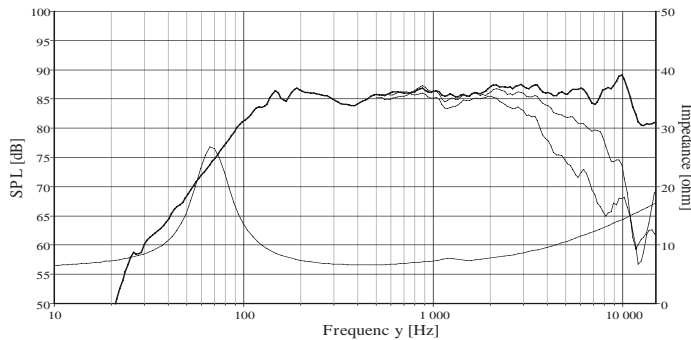

## Seas MCA15RCY H1262

The MCA15RCY is a 5" coated paper cone midrange. The classical paper cone gives a smooth and extended frequency response with a controlled roll off. The large magnet and light cone provide high sensitivity, low distortion and good transient response. The stiff injection molded basket has large windows and a raised spider to reduce sound reflection and air flow noise.

The frequency response extends to 10,000 Hz, indicating this driver is not overly damped and will have good upper midrange response.



Nominal Impedance	8 Ohms	Voice coil resistance	5.7 Ohms
Recom. frequency range	100-4000 Hz	Voice coil inductance	0.74 mH
Short term max. power	300 W	Force factor	6.8 N/A
Long term max. power	100 W	Free air resonance	51 Hz
Sensitivity (1W/1m)	90 dB	Moving mass	7.1 g
		Suspension compliance	1.3 mm/N
Voice Coil Diameter	26 mm	Suspension mech. resistance	1.53 Ns/m
Voice coil height	9.4 mm	Effective piston area	80 sq. cm
Air gap height	6.0 mm	Vas	12 Liters
Linear coil travel (p-p)	3.4 mm	Qms	1.58
Max. coil travel (p-p)	14 mm	Qes	0.30
Magnet weight	0.42 Kg	Qts	0.25
Total weight	1.3 Kg		

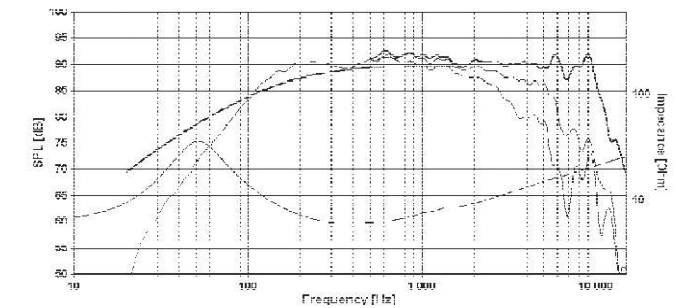

## Seas CA12RCY H1152

Natural rubber surround and hand coated paper cone with coated fabric dust cap, reduce resonances and distortion. A large magnet system and a symmetrical driving force accomplished through a special coil winding technique for the voice coil give excellent linearity. A very large magnet system provides a reasonable efficiency and a low Q. Extremely stiff and stable injection molded metal basket keeps the critical components in perfect alignment. Large windows in the basket both above and below the spider reduce sound reflection, air flow noise and cavity resonance to a minimum.



Nominal Impedance	8 Ohms	Voice coil resistance	6.4 Ohms
Recom. frequency range	45-5000 Hz	Voice coil inductance	1.05 mH
Short term max. power	200 W	Force factor	6.35 N/A
Long term max. power	60 W	Free air resonance	57 Hz
Sensitivity (1W/1m)	86 dB	Moving mass	6.1 g
		Suspension compliance	1.3 mm/N
Voice Coil Diameter	26 mm	Suspension mech. resistance	1.04 Ns/m
Voice coil height	12 mm	Effective piston area	55 sq. cm
Air gap height	6.0 mm	Vas	5 Liters
Linear coil travel (p-p)	6.0 mm	Qms	2.17
Max. coil travel (p-p)	9.0 mm	Qes	0.36
Magnet weight	0.42 Kg	Qts	0.31
Total weight	1.21 Kg		

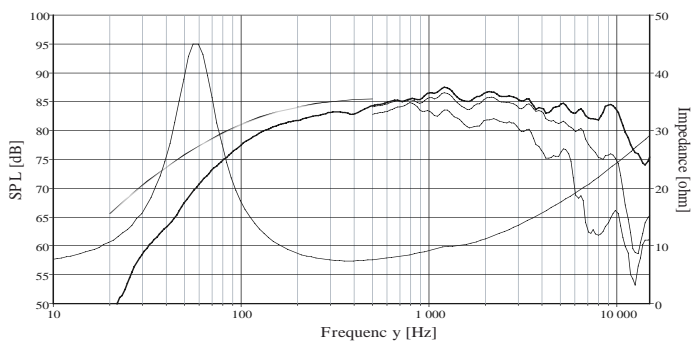

## Seas L12RCY/P H1207

The L12RCY/P is a 4.5" mini woofer with an aluminum cone, light yet stiff. The aluminum cone, coupled with the low loss rubber surround, show no sign of cone edge resonance and distortion associated with soft cones. On the other hand, cone breakup at higher frequencies call for special attention in the crossover design work. A bullet shaped phase plug reduces compression due to temperature variations in the voice coil, avoids resonance problems which would occur in the volume between the dust cap and pole piece and increases long term power handling. Raised spider VC ventilation.



Nominal Impedance	8 Ohms	Voice coil resistance	5.5 Ohms
Recom. frequency range	55-3500 Hz	Voice coil inductance	0.8 mH
Short term max. power	200 W	Force factor	5.7 N/A
Long term max. power	70 W	Free air resonance	48 Hz
Sensitivity (1W/1m)	86 dB	Moving mass	5.9 g
		Suspension compliance	1.9 mm/N
Voice Coil Diameter	26 mm	Suspension mech. resistance	0.7 Ns/m
Voice coil height	12 mm	Effective piston area	50 sq. cm
Air gap height	6.0 mm	Vas	6 Liters
Linear coil travel (p-p)	6.0 mm	Qms	2.69
Max. coil travel (p-p)	9.0 mm	Qes	0.31
Magnet weight	0.42 Kg	Qts	0.28
Total weight	1.21 Kg		

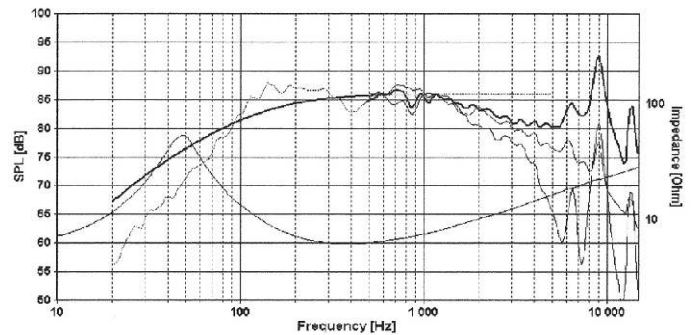

## Seas CA15RLY H1216

This 5.5" woofer was developed for use as a long throw high fidelity woofer or woofer/midrange. The CA15RLY is a coated paper cone with extended frequency range and controlled roll off. The large magnet system, together with a very long and light CCAW voice coil allow good excursion with low distortion and good transient response. The basket is a stable injection molded metal, with large windows both above and below the spider, to reduce sound reflection, air flow noise and cavity resonance. An 8 liter box can give you an F3 of 54Hz.



Nominal Impedance	8 Ohms	Voice coil resistance	5.5 Ohms
Recom. frequency range	50-4000 Hz	Voice coil inductance	0.76 mH
Short term max. power	250 W	Force factor	5.4 N/A
Long term max. power	60 W	Free air resonance	47 Hz
Sensitivity (1W/1m)	87 dB	Moving mass	8.2 g
		Suspension compliance	1.4 mm/N
Voice Coil Diameter	26 mm	Suspension mech. resistance	1.5 Ns/m
Voice coil height	16 mm	Effective piston area	80 sq. cm
Air gap height	6.0 mm	Vas	12.0 Liters
Linear coil travel (p-p)	10.0 mm	Qms	1.70
Max. coil travel (p-p)	20 mm	Qes	0.48
Magnet weight	0.42 Kg	Qts	0.37
Total weight	1.29 Kg		

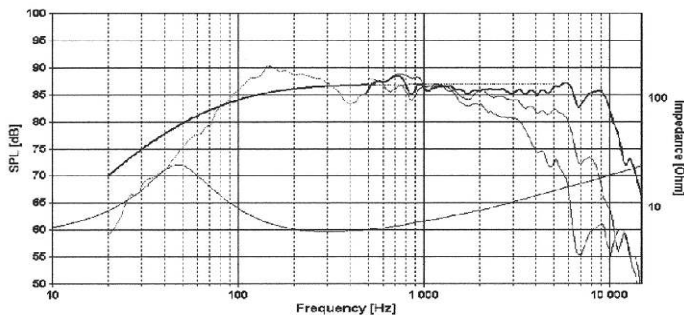

## Seas L15RLY/P H1141

This 5.5" woofer features a light, yet stiff **aluminum cone**, with a low loss rubber surround and magnesium cast frame. This driver shows no sign of the familiar 500-1500Hz cone edge resonance and distortion associated with soft cones. On the other hand, cone breakup at higher frequencies require special crossover attention. The phase plug gives low compression due to temperature variations in the voice coil, high power handling capacity and eliminates resonance which would otherwise occur in the volume between the dust cap and the pole piece. Raised Spider.



Nominal Impedance	8 Ohms	Voice coil resistance	5.9 Ohms
Recom. frequency range	45-3000 Hz	Voice coil inductance	0.61 mH
Short term max. power	200 W	Force factor	5.2 N/A
Long term max. power	80 W	Free air resonance	46 Hz
Sensitivity (1W/1m)	86 dB	Moving mass	7.3 g
		Suspension compliance	1.6 mm/N
Voice Coil Diameter	26 mm	Suspension mech. resistance	1.5 Ns/m
Voice coil height	16 mm	Effective piston area	75 sq. cm
Air gap height	6.0 mm	Vas	12.0 Liters
Linear coil travel (p-p)	10.0 mm	Qms	1.51
Max. coil travel (p-p)	20 mm	Qes	0.48
Magnet weight	0.42 Kg	Qts	0.37
Total weight	1.28 Kg		

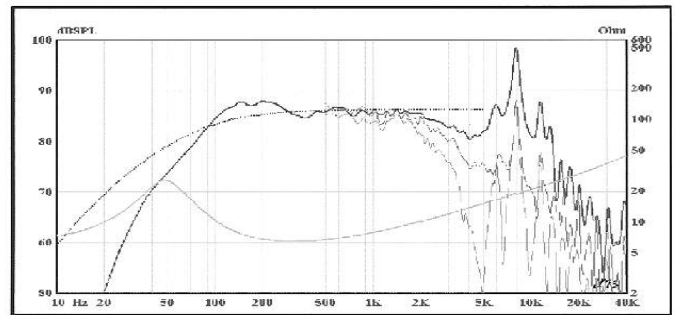

## Seas CA18RLY H1217

The CA18RLY is a classical coated paper cone woofer, but with a new high tech basket. The injection molded basket features large windows and a raised spider to reduce sound reflection, air flow noise and cavity resonance. The high temperature and light weight voice coil is wound on an aluminum former. This speaker has a natural rubber surround. The higher Qts of this driver makes it suitable for a sealed box of about 1/2 to 3/4 of a cubic foot and a resulting 3dB down point of 65Hz.



Nominal Impedance	8 Ohms	Voice coil resistance	5.9 Ohms
Recom. frequency range	35-2500 Hz	Voice coil inductance	0.70 mH
Short term max. power	250 W	Force factor	5.6 N/A
Long term max. power	80 W	Free air resonance	40 Hz
Sensitivity (1W/1m)	88 dB	Moving mass	11.5 g
		Suspension compliance	1.3 mm/N
Voice Coil Diameter	26 mm	Suspension mech. resistance	1.6 Ns/m
Voice coil height	16 mm	Effective piston area	130 sq. cm
Air gap height	6 mm	Vas	30 Liters
Linear coil travel (p-p)	10 mm	Qms	1.94
Max. coil travel (p-p)	20 mm	Qes	0.58
Magnet weight	0.42 Kg	Qts	0.45
Total weight	1.41 Kg		

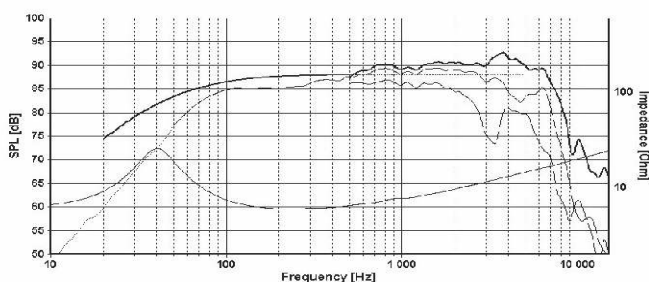

## Seas CA18RNX H1215

This 7" driver was designed for use as a long throw hi-fi woofer or bass/midrange unit. The classical coated paper cone gives a smooth extended frequency response with a controlled roll off. The large magnet system provides good transient response. The bumped back plate, together with the very long and light weight copper clad aluminum voice coil allow for extreme coil excursion with low distortion. The stiff injection molded cast frame has large windows both above and below the spider, to reduce sound reflection, air noise and cavity resonance. An Fs of 45 Hz can be achieved in an 18 lt



Nominal Impedance	8 Ohms	Voice coil resistance	6.1 Ohms
Recom. frequency range	45-3000 Hz	Voice coil inductance	1.1 mH
Short term max. power	250 W	Force factor	6.4 N/A
Long term max. power	80 W	Free air resonance	36 Hz
Sensitivity (1W/1m)	88 dB	Moving mass	12 g
		Suspension compliance	1.6 mm/N
Voice Coil Diameter	39 mm	Suspension mech. resistance	1.7 Ns/m
Voice coil height	18 mm	Effective piston area	130 sq. cm
Air gap height	6.0 mm	Vas	36 Liters
Linear coil travel (p-p)	12 mm	Qms	1.70
Max. coil travel (p-p)	22 mm	Qes	0.43
Magnet weight	0.64 Kg	Qts	0.35
Total weight	1.91 Kg		

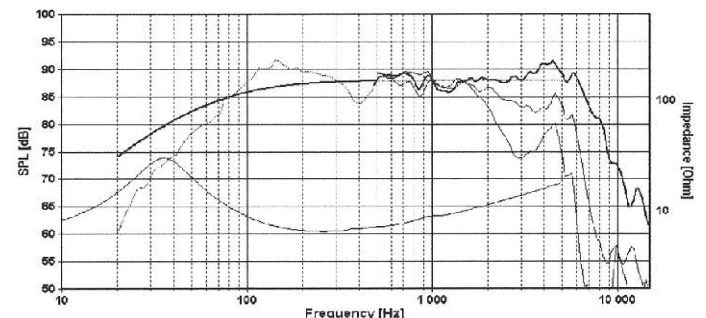



## Seas L18RNXP H1224

7" aluminum cone woofer. The stiff cone coupled with the low loss rubber surround shows no sign of cone edge resonance and distortion associated with soft cones. Tremendous bass precision. A bullet shaped phase plug reduces compression due to temperature variations in the voice coil, avoids resonance problems which would occur in the volume between the dust cap and pole piece and increases long term power handling. Large magnet for good efficiency. Raised Spider and bumped back plate for increased power handling and lower mechanical distortion.



Nominal Impedance	8 Ohms	Voice coil resistance	6.1 Ohms
Recom. frequency range	40-2500 Hz	Voice coil inductance	1.0 mH
Short term max. power	250 W	Force factor	6.7 N/A
Long term max. Power	100 W	Free air resonance	33 Hz
Sensitivity (1W/1m)	87 dB	Moving mass	14 g
		Suspension compliance	1.7 mm/N
Voice Coil Diameter	39 mm	Suspension mech. resistance	1.6 Ns/m
Voice coil height	18.0 mm	Effective piston area	126 sq. cm
Air gap height	6.0 mm	Vas	35.0 Liters
Linear coil travel (p-p)	12.0 mm	Qms	1.89
Max. coil travel (p-p)	22.0 mm	Qes	0.42
Magnet weight	0.64 Kg	Qts	0.34
Total weight	1.92 Kg		

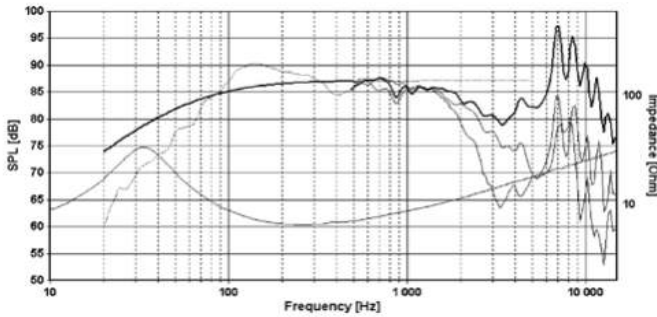

## Seas P18RNXP H1350

7" Polypropylene cone woofer, coupled with a high loss rubber surround. Tremendous bass precision. A bullet shaped phase plug reduces compression due to temperature variations in the voice coil, avoids resonance problems which would occur in the volume between the dust cap and pole piece and increases long term power handling. Large magnet for good efficiency. Raised Spider and bumped back plate for increased power handling and lower mechanical distortion. This driver is an excellent choice for use in a satellite speaker or stand alone bookshelf speaker.



Nominal Impedance	8 Ohms	Voice coil resistance	5.7 Ohms
Recom. frequency range	45-3000 Hz	Voice coil inductance	1.0 mH
Short term max. power	250 W	Force factor	7.0 N/A
Long term max. Power	80 W	Free air resonance	43 Hz
Sensitivity (1W/1m)	89 dB	Moving mass	12.2 g
		Suspension compliance	1.12 mm/N
Voice Coil Diameter	39 mm	Suspension mech. resistance	1.46 Ns/m
Voice coil height	18.0 mm	Effective piston area	126 sq. cm
Air gap height	6.0 mm	Vas	24.9 Liters
Linear coil travel (p-p)	12.0 mm	Qms	2.26
Max. coil travel (p-p)	22.0 mm	Qes	0.39
Magnet weight	0.64 Kg	Qts	0.33
Total weight	1.92 Kg		

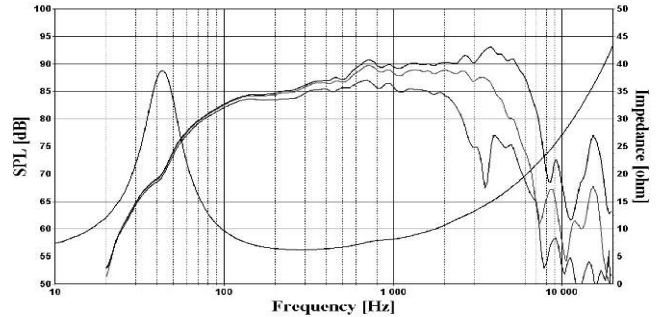

## Seas CA22RNXP H1288

A hand coated paper cone and matching natural rubber surround produce a well behaved roll off characteristic and reduce potential resonance problems. A long voice coil wound on an aluminum former gives low distortion and high power handling. The large magnet system provides high efficiency and good transient response. A bumped backplate in the magnet system allow maximum utilization of the long voice coil without mechanical limitation. Large windows in the basket both above and below the spider reduce sound reflections, air flow noise and cavity resonance.



Nominal Impedance	8 Ohms	Voice coil resistance	6.1 Ohms
Recom. frequency range	30-3000 Hz	Voice coil inductance	1.0 mH
Short term max. power	250 W	Force factor	7.0 N/A
Long term max. power	80 W	Free air resonance	29 Hz
Sensitivity (1W/1m)	89.5 dB	Moving mass	20.9 g
		Suspension compliance	1.4 mm/N
Voice Coil Diameter	39 mm	Suspension mech. resistance	2.05 Ns/m
Voice coil height	18 mm	Effective piston area	230 sq. cm
Air gap height	6 mm	Vas	97 Liters
Linear coil travel (p-p)	12 mm	Qms	2.04
Max. coil travel (p-p)	26 mm	Qes	0.52
Magnet weight	0.64 Kg	Qts	0.41
Total weight	2.2 Kg		

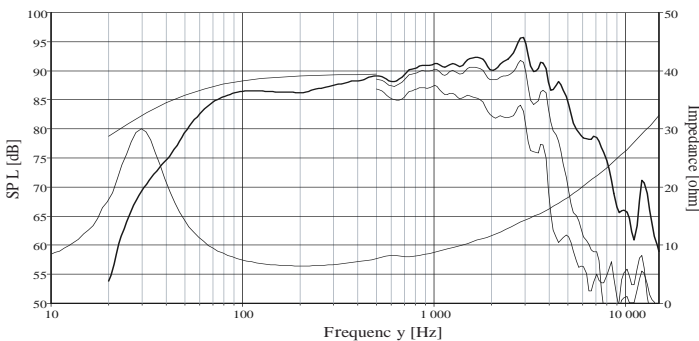

## Seas L22RN4XP H1208

The L22RN4XP is an 8" aluminum cone woofer, very light and stiff. The stiff cone provides tremendous bass precision. The aluminum cone and low loss rubber surround show no sign of the familiar 500-1500Hz cone edge resonance. The high temperature voice coil on aluminum former provide excellent power handling. The phase plug reduces compression due to temperature variations in the voice coil, and eliminates resonances that can occur in the gap between the dust cap and pole piece. The resonance at higher frequencies require some special crossover work. **4 Layer Voice Coil**



Nominal Impedance	8 Ohms	Voice coil resistance	6.1 Ohms
Recom. frequency range	20-1000 Hz	Voice coil inductance	3.5 mH
Short term max. power	300 W	Force factor	10.7 N/A
Long term max. power	125 W	Free air resonance	23 Hz
Sensitivity (1W/1m)	86 dB	Moving mass	43 g
		Suspension compliance	1.1 mm/N
Voice Coil Diameter	39 mm	Suspension mech. resistance	1.8 Ns/m
Voice coil height	20 mm	Effective piston area	220 sq. cm
Air gap height	6.0 mm	Vas	72 Liters
Linear coil travel (p-p)	14.0 mm	Qms	3.62
Max. coil travel (p-p)	21.0 mm	Qes	0.35
Magnet weight	0.64 Kg	Qts	0.32
Total weight	2.2 Kg		

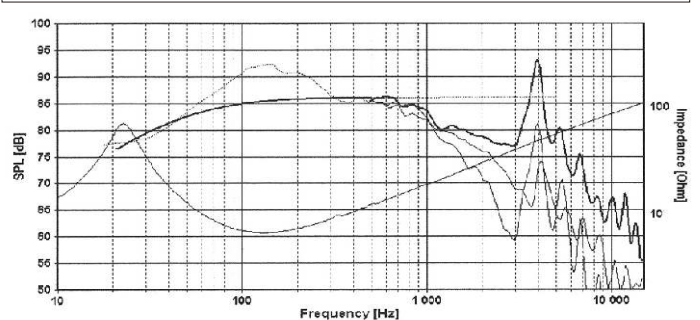



## Seas L22RNX/P H1252

The L22RNX/P is an 8" aluminum cone woofer, very light and stiff. The stiff cone provides tremendous bass precision. The aluminum cone and low loss rubber surround show no sign of the familiar 500-1500Hz cone edge resonance. The high temperature voice coil on aluminum former provide excellent power handling. The phase plug reduces compression due to temperature variations in the voice coil, and eliminates resonances that can occur in the gap between the dust cap and pole piece. The resonance at higher frequencies require some special crossover work. **2 Layer Voice Coil**



Nominal Impedance	8	Ohms	Voice coil resistance	6.0	Ohms
Recom. frequency range	25-1000	Hz	Voice coil inductance	1.25	mH
Short term max. power	300	W	Force factor	7.8	N/A
Long term max. power	110	W	Free air resonance	23	Hz
Sensitivity (1W/1m)	88	dB	Moving mass	26.1	g
			Suspension compliance	1.7	mm/N
Voice Coil Diameter	39	mm	Suspension mech. resistance	2.1	Ns/m
Voice coil height	18	mm	Effective piston area	220	sq. cm
Air gap height	6.0	mm			
Linear coil travel (p-p)	12.0	mm	Vas	116	Liters
Max. coil travel (p-p)	21.0	mm	Qms	1.93	
Magnet weight	0.64	Kg	Qes	0.40	
Total weight	2.2	Kg	Qts	0.33	

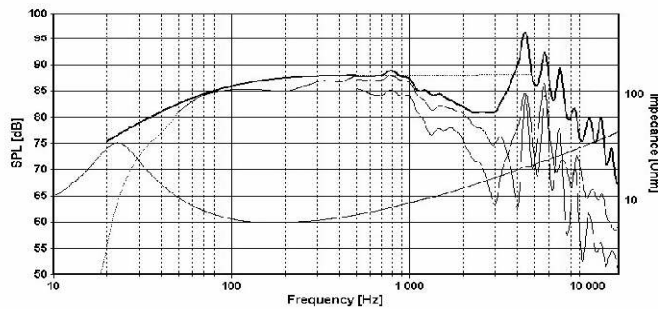

## Seas CA26RE4X H1316

A classical manually coated paper cone and matching natural rubber surround produce a smooth response and reduce potential resonance problems. A **four layer voice coil** provides a well behaved roll off characteristic. A large magnet system gives good sensitivity and transient response. Extremely stiff and stable injection molded metal basket keeps the critical components in perfect alignment. Large windows in the basket both above and below the spider reduce sound reflection, and keep air flow noise and cavity resonance to a minimum. **39mm voice coil Ø, 4mm x-max**



Nominal Impedance	8	Ohms	Voice coil resistance	6.1	Ohms
Recom. frequency range	30-1500	Hz	Voice coil inductance	3.08	mH
Short term max. power	300	W	Force factor	11.6	N/A
Long term max. power	80	W	Free air resonance	25	Hz
Sensitivity (1W/1m)	91	dB	Moving mass	38.5	g
			Suspension compliance	1.1	mm/N
Voice Coil Diameter	39	mm	Suspension mech. resistance	1.66	Ns/m
Voice coil height	14	mm	Effective piston area	350	sq. cm
Air gap height	6	mm			
Linear coil travel (p-p)	8	mm	Vas	164	Liters
Max. coil travel (p-p)	20	mm	Qms	3.99	
Magnet weight	0.64	Kg	Qes	0.30	
Total weight	2.17	Kg	Qts	0.28	

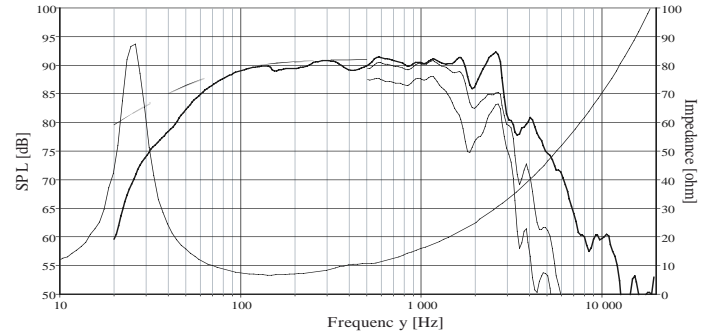

## Seas CA26RFX H1305

A classical hand coated paper cone and matching natural rubber surround produce a well behaved roll off characteristic and reduce potential resonance problems. A 2" high temperature voice coil with black anodized aluminum coil former gives high power handling and reduced power compression. A large magnet system gives good sensitivity and transient response. A bumped backplate in the magnet system allow maximum excursion. Large windows in the basket both above and below the spider reduce reflection, air flow noise and cavity resonance. **51mm VC Ø, 7mm x-max**



Nominal Impedance	8	Ohms	Voice coil resistance	6.3	Ohms
Recom. frequency range	30-1000	Hz	Voice coil inductance	1.95	mH
Short term max. power	300	W	Force factor	10.7	N/A
Long term max. power	100	W	Free air resonance	29	Hz
Sensitivity (1W/1m)	90.5	dB	Moving mass	36.1	g
			Suspension compliance	0.8	mm/N
Voice Coil Diameter	51	mm	Suspension mech. resistance	3.4	Ns/m
Voice coil height	20	mm	Effective piston area	350	sq. cm
Air gap height	6	mm			
Linear coil travel (p-p)	14	mm	Vas	129	Liters
Max. coil travel (p-p)	35	mm	Qms	2.14	
Magnet weight	3.0	Kg	Qes	0.40	
Total weight	4.5	Kg	Qts	0.34	

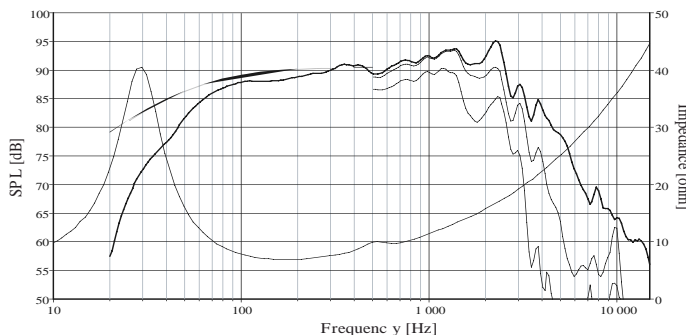

## Seas L26RFX/P H1209

This 10" woofer features a light, yet stiff aluminum cone for stiffness in providing bass precision. Large windows both above and below the spider in the injection molded metal basket help reduce air flow noise, sound reflections and cavity resonance. The low loss rubber surround shows no sign of the familiar edge resonance. Cone breakup at higher frequencies need to be addressed in the crossover design. A 2" diameter high temperature voice coil with black anodized aluminum former gives high power handling and reduce compression. The phase plug helps eliminate resonances.



Nominal Impedance	8	Ohms	Voice coil resistance	6.3	Ohms
Recom. frequency range	20-1000	Hz	Voice coil inductance	1.48	mH
Short term max. power	300	W	Force factor	10.7	N/A
Long term max. power	125	W	Free air resonance	20	Hz
Sensitivity (1W/1m)	87	dB	Moving mass	58	g
			Suspension compliance	1.1	mm/N
Voice Coil Diameter	51	mm	Suspension mech. resistance	3.18	Ns/m
Voice coil height	20	mm	Effective piston area	330	sq. cm
Air gap height	6.0	mm			
Linear coil travel (p-p)	14.0	mm	Vas	166	Liters
Max. coil travel (p-p)	35	mm	Qms	2.30	
Magnet weight	3.0	Kg	Qes	0.40	
Total weight	4.05	Kg	Qts	0.34	

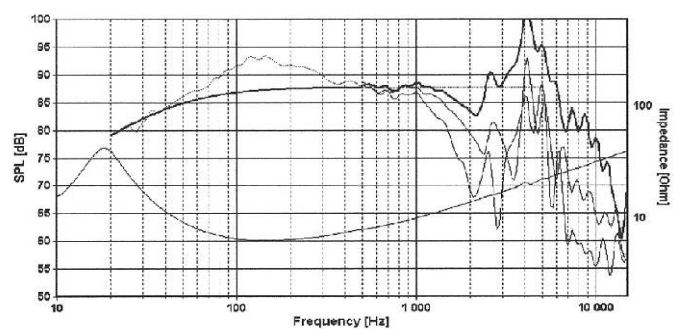

## Seas SP17R H9928

This 6.5" passive radiator is intended for use as an alternative to the vented port in a bass reflex cabinet. In many applications a traditional port may produce air noise which is often improved by use of a passive radiator instead.

The cone is equipped with a 4mm screw to which you can easily affix added mass.

For optimum performance the passive radiator should be mounted vertically. This is especially important when significant additional mass is used. Polypropylene cone, rubber surround, and injection molded zinc frame.



Nominal Impedance	Ohms	Voice coil resistance	Ohms
Recom. frequency range	Hz	Voice coil inductance	mH
Short term max. Power	W	Force factor	N/A
Long term max. Power	W	Free air resonance	26 Hz
Sensitivity (1W/1m)	dB	Moving mass	21.5 g
		Suspension compliance	1.74 mm/N
Voice Coil Diameter	mm	Suspension mech. resistance	Ns/m
Voice coil height	mm	Effective piston area	130 sq. cm
Air gap height	mm		
Linear coil travel (p-p)	mm	Vas	41 Liters
Max. coil travel (p-p)	19 mm	Qms	
Magnet weight	Kg	Qes	
Total weight	.30 Kg	Qts	

Passive radiator chart SP17R

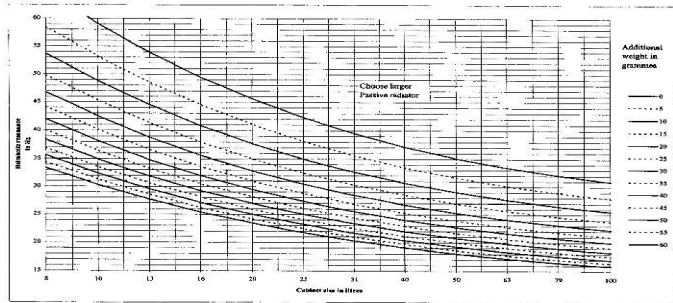

## Seas SP21R H9901

This 8" passive radiator is intended for use as an alternative to the vented port in a bass reflex cabinet. In many applications a traditional port may produce air noise which is often improved by use of a passive radiator instead.

The cone is equipped with a 4mm screw to which you can easily affix added mass.

For optimum performance the passive radiator should be mounted vertically. This is especially important when significant additional mass is used. Polypropylene cone, rubber surround, and injection molded zinc frame.



Nominal Impedance	Ohms	Voice coil resistance	Ohms
Recom. frequency range	Hz	Voice coil inductance	mH
Short term max. power	W	Force factor	N/A
Long term max. Power	W	Free air resonance	22 Hz
Sensitivity (1W/1m)	dB	Moving mass	28 g
		Suspension compliance	1.87 mm/N
Voice Coil Diameter	mm	Suspension mech. resistance	Ns/m
Voice coil height	mm	Effective piston area	230 sq. cm
Air gap height	mm		
Linear coil travel (p-p)	mm	Vas	138 Liters
Max. coil travel (p-p)	20 mm	Qms	
Magnet weight	Kg	Qes	
Total weight	.45 Kg	Qts	

Passive radiator chart SP21R

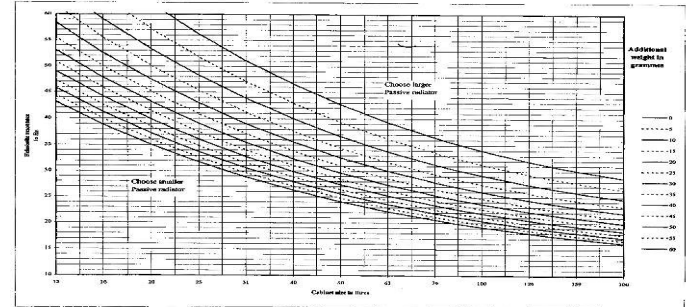

## Seas SP25R H9902

This 10" passive radiator is intended for use as an alternative to the vented port in a bass reflex cabinet. In many applications a traditional port may produce air noise which is often improved by use of a passive radiator instead.

The cone is equipped with a 4mm screw to which you can easily affix added mass.

For optimum performance the passive radiator should be mounted vertically. This is especially important when significant additional mass is used. Polypropylene cone, rubber surround, and injection molded zinc frame.



Nominal Impedance	Ohms	Voice coil resistance	Ohms
Recom. frequency range	Hz	Voice coil inductance	mH
Short term max. power	W	Force factor	N/A
Long term max. Power	W	Free air resonance	22 Hz
Sensitivity (1W/1m)	dB	Moving mass	42 g
		Suspension compliance	1.25 mm/N
Voice Coil Diameter	mm	Suspension mech. resistance	Ns/m
Voice coil height	mm	Effective piston area	350 sq. cm
Air gap height	mm		
Linear coil travel (p-p)	mm	Vas	214 Liters
Max. coil travel (p-p)	25 mm	Qms	
Magnet weight	Kg	Qes	
Total weight	.65 Kg	Qts	

Passive radiator chart SP25R

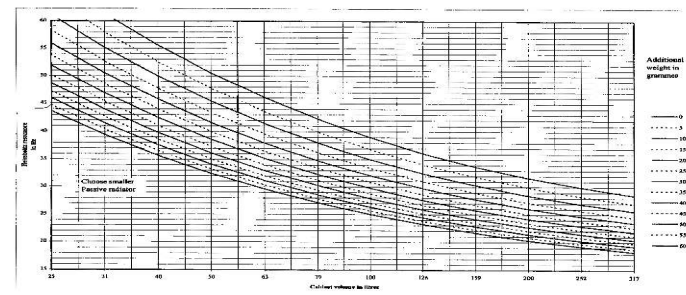

## Seas T18REX/XFC H1353

A PP/TPX based cone matches ideally with an **adaptive rubber surround**. The result is an outstandingly smooth frequency response from the mid woofer. A coaxially arranged pre-coated fabric dome high frequency unit with a low resonance frequency, integrates with the cone driver to a point source. The cone of the woofer acts as a horn loading for the tweeter, and the chassis of the dome unit represents the throat of this horn. This unshielded version is ideal for smaller enclosures. F3 of 60Hz in 0.3 cubic foot enclosure with a 1.5" diameter vent by 5" long. Crossover available separately.



	Tweeter/Woofer		Voice coil resistance	4.8/6.1	Ohms
Nominal Impedance	6/8	Ohms	Voice coil inductance	0.05/0.7	mH
Recom. frequency range	40-25000	Hz	Force factor	2.3/7.5	N/A
Short term max. power	220/250	W	Free air resonance	1200/29	Hz
Long term max. power	90/80	W	Moving mass	0.3/13.6	g
Sensitivity (1W/1m)	88.5/87	dB	Suspension compliance	-2/38	mm/N
Voice Coil Diameter	26/39	mm	Suspension mech. resistance	-/-	Ns/m
Voice coil height	1.5/12	mm	Effective piston area	7.0/120	sq. cm
Air gap height	2.0/6.0	mm			
Linear coil travel (p-p)	0.5/6.0	mm	Vas	-/47.9	Liters
Max. coil travel (p-p)	-/20	mm	Qms	-/1.50	
Magnet weight	-/0.64	Kg	Qes	-/0.26	
Total weight		Kg	Qts	-/0.22	

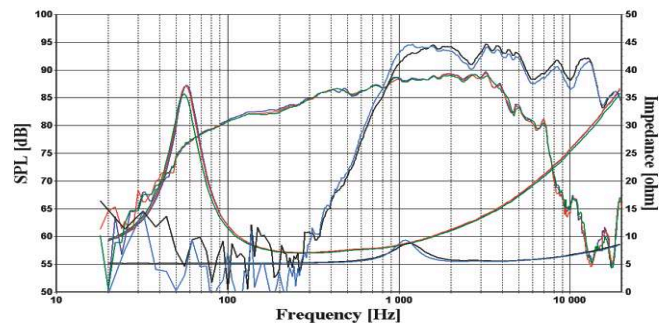



# Seas T18RE/XFCTV2 H1333

A PP/TPX based cone matches ideally with an **adaptive rubber surround**. The result is an outstandingly smooth frequency response from the mid woofer. A coaxially arranged pre-coated fabric dome tweeter with a low resonance frequency, integrates with the cone driver to a point source. The cone of the woofer acts as a horn loading for the tweeter, and the chassis of the dome unit represents the throat of this horn. A compensation magnet and a shielding cup is mounted on the woofer magnet system to eliminate magnetic stray fields, hence the unit can be used very close to CRT's in audio/video applications.

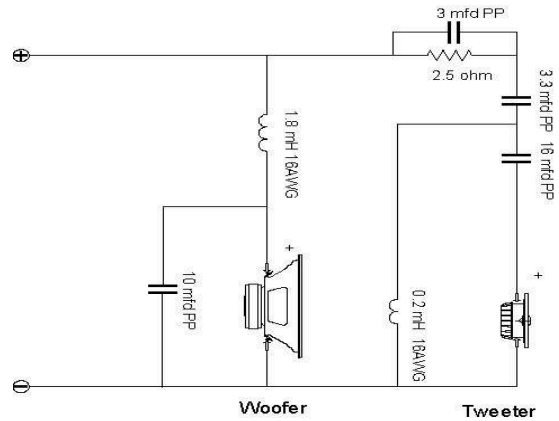

Crossover for All Coaxials \$36.50 each.

Tweeter/Woofers	6/8	Ohms	Voice coil resistance	4.8/6.1	Ohms
Nominal Impedance	30-25000	Hz	Voice coil inductance	0.05/0.79	mH
Recom. frequency range	220/250	W	Force factor	2.3/6.8	N/A
Short term max. power	90/80	W	Free air resonance	1200/26	Hz
Long term max. power	88.5/87	dB	Moving mass	0.3/13.7	g
Sensitivity (1W/1m)	26/39	mm	Suspension compliance	-2.7	mm/N
Voice Coil Diameter	1.5/12	mm	Suspension mech. resistance	-1.45	Ns/m
Voice coil height	2.0/6.0	mm	Effective piston area	7.0/120	sq. cm
Air gap height	0.5/6.0	mm	Vas	-/52	Liters
Linear coil travel (p-p)	-20	mm	Qms	-/1.63	
Max. coil travel (p-p)	-0.84	Kg	Qes	-/0.31	
Magnet weight	1.91	Kg	Qts	-/0.26	
Total weight					

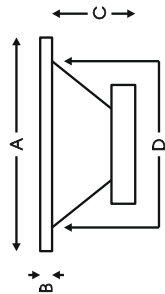
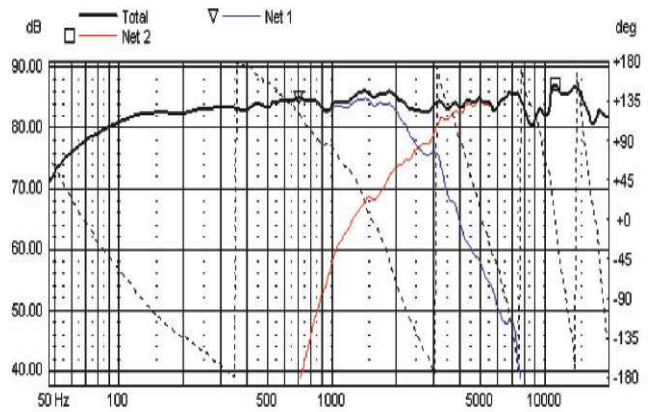
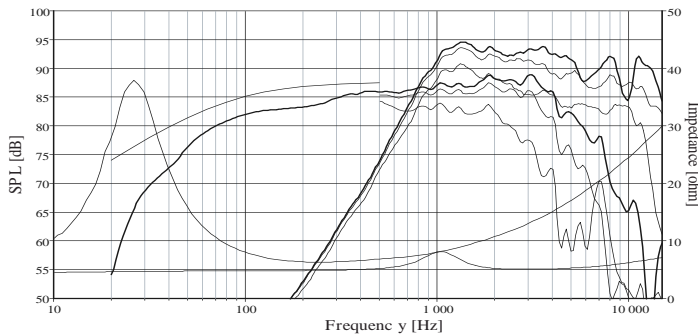

1" = 25.4mm = 2.54cm

Driver Dimensions in millimeters, from smallest to largest size. 25.4mm = 1" = 2.54cm				
Unit	A mm	B mm	C mm	D mm
(H0625) / (H1396)&(H1397)	60 / 53	2.1 / 0.5	18 / 21.5	45.9 / 46
(H0737)	93.8	3.1	18.4	66.5
(H1283)	97.7	3.5	24	73
(H1210)	103.8	3.5	28.4	74.5
(H0881), (H1147), (H1149), (H1212), (H1189)	103.8	3.5	39.5	74.8
(H0831), (H1211)	103.8	3.6	24.4	74.8
(1322), (1318)	103.8	6	24.5	73
(E0038), (E0039), (E0040)	110.3	5.5	37.5	75
(E0006), (E0036), *(E0011)	110.4	6.3	53, *35	75
(E0021), (H1207), (H1152), *(H1304)	120.4	5	58.5, *55.5	95.8
(E0015), (H1141), (H1216), (H1262), *(E0041)	146	4.2	67.3, *75.5	112
(E0037), (E0043)	146	4.2	77	112
(H9928) passive radiator	170.4	3.8	42.5	145.3
(H1350),(E0018), (E0017), (H1224), (H1215), *(E0042)	176	5.2	80, *81	145.2
(H1143), (E0027)	176	5.2	100.3	145.2
(H1144), (H1333), *(H1353)	176	5.2	100.5, *84	145.2
(H9901) passive radiator	215.4	4.7	51	186.8
(E0022), (H1208), (H1252), (H1288)	221.4	5.5	90	186.4
(H9902) passive radiator	261.2	4.2	58	229
(E0046),(E0026), (H1209), (H1305), *(H1316)	269	5.8	107.5, *100.5	232.2

In the late 1920s, at the Norwegian Institute of Technology (NTH), the first Norwegian electrodynamic loudspeaker drivers were designed. Ever since, Norwegian engineers have been leading the technology race in driver design. From its founding in 1950 as a spin-off of the Norwegian radio manufacturers Radionette and Tandberg, SEAS has been dedicated to creating loudspeakers with superior sound reproduction.

A company owned by its employees, SEAS takes pride in the drivers it has tailored to meet specific customer demands and in the major role it plays in creating the "sound experience" of the contemporary Hi-Fi market. We are committed to offering products of the highest standard and the support services needed to meet the changing demands of the global marketplace.





**YAG20-1 \$39.60**



**Silver Flute Ribbon**

- Kapton film membrane
- Copper conductors over 90% of surface
- Two rows of Neodymium bar magnets
- Wave guide flange
- Flat impedance
- 8 ohm
- 90 dB
- 3kHz to 20kHz frequency range
- 80 watt power handling @ 3kHz
- Flange: 3.5" x 6.25

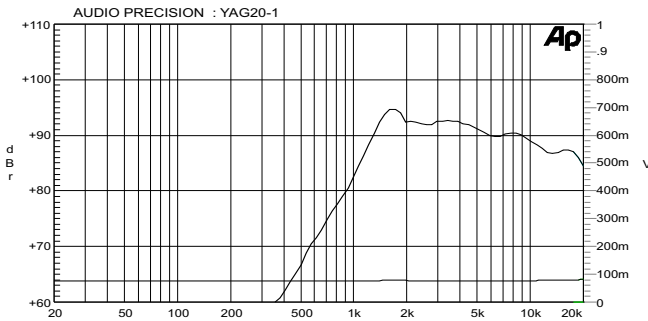

**W14RC25-04 \$17.50**



**Silver Flute**

- 5-1/2"
- Wool Cone
- Cast Frame
- 25mm VC Ø
- Vented Pole Piece
- Rubber Surround
- F3 of 75Hz in 0.2 ft<sup>3</sup> ported enclosure

Re	3.7	Ohms	BL	5.07	TM
Sensitivity	90	dB	X-max	3.5	mm
Power	60	watts	Le @ 1kHz	0.52	mH
Fs	42.5	Hz	Frame Ø	142	mm
Qms	3.70		Cutout Ø	122	mm
Qes	0.31		Depth	67	mm
Qts	0.28		Krm	0.913	mΩ
Vas	19.0	Ltrs	Kxm	8.302	mH
Mms	7.95	g	Erms	0.840	
Cms	1767.6	μM/N	Exms	0.684	
Sd	0.0087	M <sup>2</sup>	Box Rec.:	7 ltrs, 1.5"Ø V x 4.25" L	

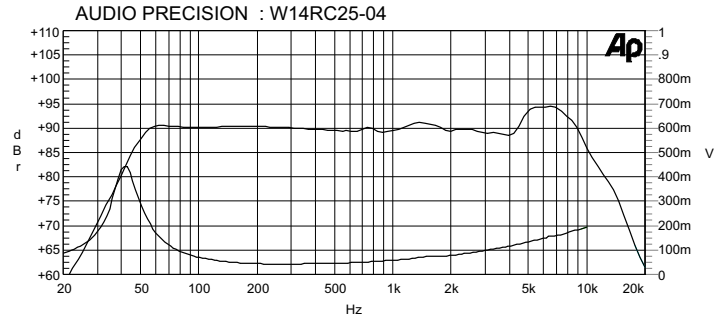

**W14RC25-S-04 \$19.40**



**Silver Flute**

- 5-1/2"
- Wool Cone
- Cast Frame
- **Shielded** Magnet
- 25mm VC Ø
- Rubber Surround
- F3 of 52Hz in 0.35 ft<sup>3</sup> ported enclosure

Re	3.7	Ohms	BL	4.53	TM
Sensitivity	89	dB	X-max	3.5	mm
Power	60	watts	Le @ 1kHz	0.49	mH
Fs	48.2	Hz	Frame Ø	142	mm
Qms	4.06		Cutout Ø	122	mm
Qes	0.46		Depth	75	mm
Qts	0.41		Krm	1.100	mΩ
Vas	13.95	Ltrs	Kxm	7.405	mH
Mms	8.41	g	Erms	0.819	
Cms	1297.9	μM/N	Exms	0.690	
Sd	0.0087	M <sup>2</sup>	Box Rec.:	10 ltrs, 1.5"Ø V x 4.4" L	

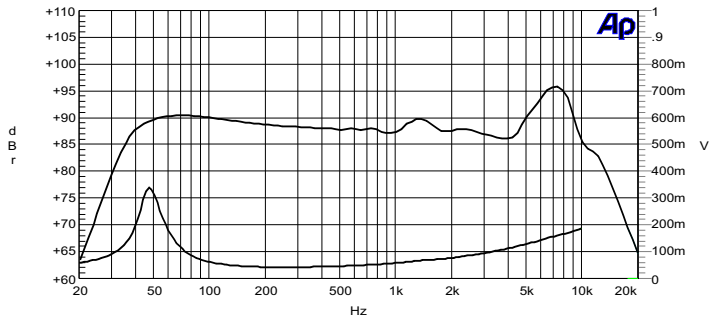

**W14RC25-08 \$17.50**



**Silver Flute**

- 5-1/2"
- Wool Cone
- Cast Frame
- 25mm VC Ø
- Vented Pole Piece
- Rubber Surround
- F3 of 55Hz in 0.35 ft<sup>3</sup> ported enclosure

Re	7.3	Ohms	BL	6.24	TM
Sensitivity	87.5	dB	X-max	3.5	mm
Power	60	watts	Le @ 1kHz	0.77	mH
Fs	43.5	Hz	Frame Ø	142	mm
Qms	3.27		Cutout Ø	122	mm
Qes	0.39		Depth	67	mm
Qts	0.35		Krm	0.876	mΩ
Vas	18.9	Ltrs	Kxm	11.549	mH
Mms	7.58	g	Erms	0.882	
Cms	1760.5	μM/N	Exms	0.691	
Sd	0.0087	M <sup>2</sup>	Box Rec.:	10 ltrs, 1.5" Ø V x 4.25" L	

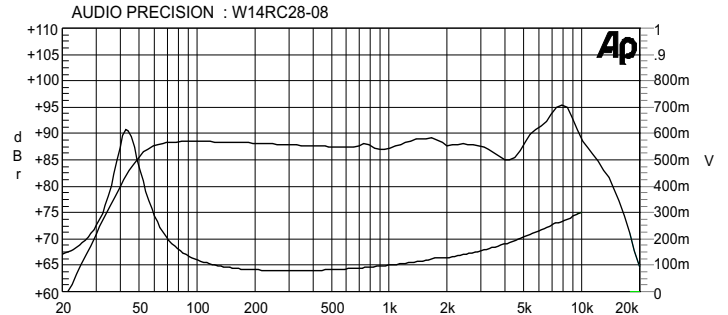

**W14RC25-S-08 \$19.40**



**Silver Flute**

- 5-1/2"
- **Shielded** Magnet
- Wool Cone
- Cast Frame
- 25mm VC Ø
- Rubber Surround
- F3 of 75Hz in 0.32 ft<sup>3</sup> sealed enclosure

Re	7.3	Ohms	BL	5.76	TM
Sensitivity	87	dB	X-max	3.5	mm
Power	60	watts	Le @ 1kHz	0.79	mH
Fs	43.5	Hz	Frame Ø	142	mm
Qms	3.37		Cutout Ø	122	mm
Qes	0.46		Depth	75	mm
Qts	0.40		Krm	0.967	mΩ
Vas	18.9	Ltrs	Kxm	11.129	mH
Mms	7.63	g	Erm	0.875	
Cms	1757.5	μM/N	Exm	0.697	
Sd	0.0087	M <sup>2</sup>	Box Rec.:	9 liters sealed	

**W17RC38-04 \$24.60**



**Silver Flute**

- 6-1/2"
- Wool Cone
- Cast Frame
- 38mm VC Ø
- Rubber Surround
- Vented Pole Piece
- F3 of 75Hz in 0.21 ft<sup>3</sup> vented

Re	3.7	Ohms	BL	7.31	TM
Sensitivity	91.5	dB	X-max	5	mm
Power	80	watts	Le @ 1kHz	0.53	mH
Fs	37.5	Hz	Frame Ø	167	mm
Qms	1.52		Cutout Ø	147	mm
Qes	0.28		Depth	75	mm
Qts	0.24		Krm	1.370	mΩ
Vas	25.6	Ltrs	Kxm	17.805	mH
Mms	17.4	g	Erm	0.818	
Cms	1036.1	μM/N	Exm	0.599	
Sd	0.0132	M <sup>2</sup>	Box Rec.:	6 liters vented 1.5" Ø x 5.5" L	

AUDIO PRECISION : W14RC25-S-08

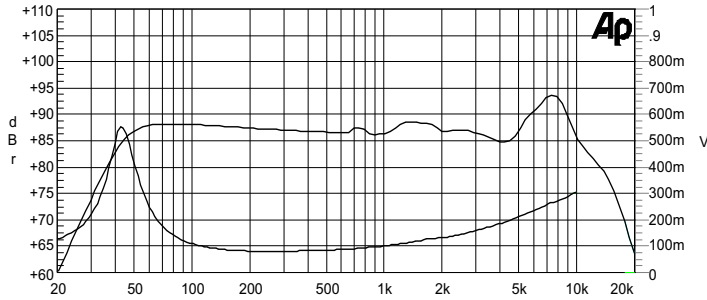

AUDIO PRECISION : W17RC38-04

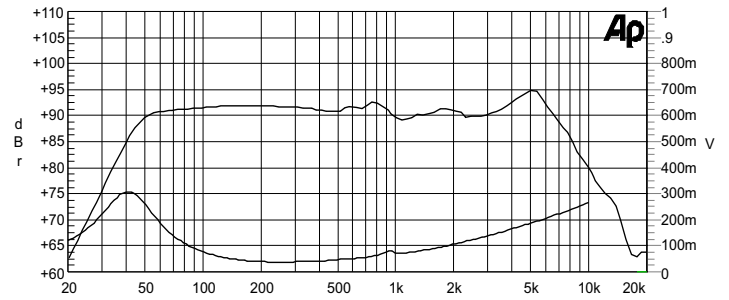

**W17RC38-S-04 \$30.70**



**Silver Flute**

- 6-1/2"
- Wool Cone
- **Shielded** Magnet
- Cast Frame
- 38mm VC Ø
- Rubber Surround
- F3 of 50Hz in 0.48 ft<sup>3</sup> vented

Re	3.7	Ohms	BL	6.02	TM
Sensitivity	90	dB	X-max	5	mm
Power	80	watts	Le @ 1kHz	0.51	mH
Fs	43.1	Hz	Frame Ø	167	mm
Qms	1.83		Cutout Ø	147	mm
Qes	0.42		Depth	93	mm
Qts	0.34		Krm	1.025	mΩ
Vas	22.4	Ltrs	Kxm	15.716	mH
Mms	15.1	g	Erm	0.844	
Cms	903.8	μM/N	Exm	0.607	
Sd	0.0132	M <sup>2</sup>	Box Rec.:	14 liters vented 2" Ø x 5.6" L	

**W17RC38-08 \$24.60**



**Silver Flute**

- 6-1/2"
- Wool Cone
- Cast Frame
- 38mm VC Ø
- Rubber Surround
- Vented Pole Piece
- F3 of 60Hz in 0.42 ft<sup>3</sup> vented enclosure

Re	7.3	Ohms	BL	8.26	TM
Sensitivity	89	dB	X-max	5	mm
Power	80	watts	Le @ 1kHz	0.94	mH
Fs	40.5	Hz	Frame Ø	167	mm
Qms	1.52		Cutout Ø	147	mm
Qes	0.36		Depth	75	mm
Qts	0.29		Krm	2.001	mΩ
Vas	28.2	Ltrs	Kxm	36.187	mH
Mms	13.57	g	Erm	0.836	
Cms	1140.0	μM/N	Exm	0.582	
Sd	0.0132	M <sup>2</sup>	Box Rec.:	12 ltrs, 2" Ø V x 6" L	

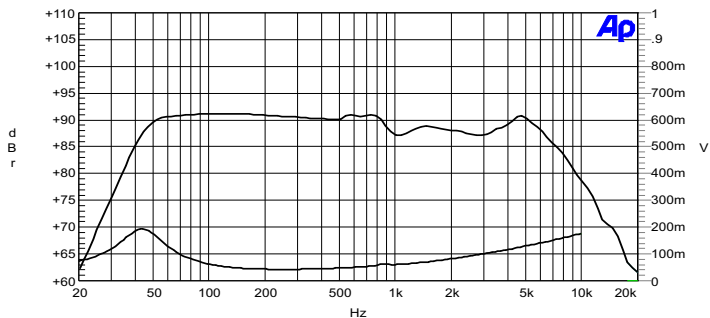

AUDIO PRECISION : W17RC38-08

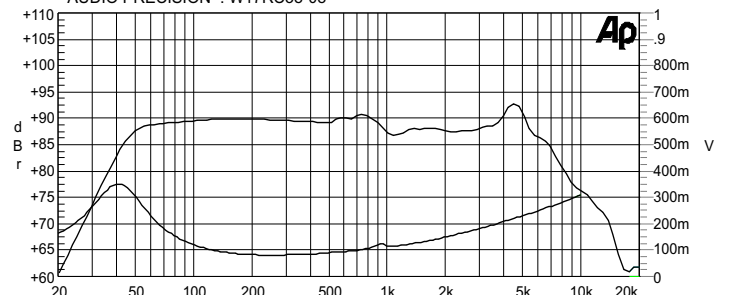

**W17RC38-S-08 \$30.70**

**Silver Flute**



- 6-1/2"
- Wool Cone
- **Shielded** Magnet
- Cast Frame
- 38mm VC Ø
- Rubber Surround
- F3 of 54Hz in 0.46 ft<sup>3</sup> vented enclosure

**W20RC38-04 \$31.20**

**Silver Flute**



- 8"
- Wool Cone
- Cast Frame
- 38mm VC Ø
- Rubber Surround
- Vented Pole Piece
- F3 of 60Hz in 0.53ft<sup>3</sup> vented enclosure

Re	7.3	Ohms	BL	8.33	TM
Sensitivity	88	dB	X-max	5	mm
Power	80	watts	Le @ 1kHz	0.89	mH
Fs	41.3	Hz	Frame Ø	167	mm
Qms	1.45		Cutout Ø	147	mm
Qes	0.40		Depth	93	mm
Qts	0.31		Krm	2.424	mΩ
Vas	24.3	Ltrs	Kxm	30.319	mH
Mms	15.1	g	Erm	0.815	
Cms	982.3	μM/N	Exm	0.597	
Sd	0.0132	M <sup>2</sup>	Box Rec.:	13 ltrs, 2" Ø V x 6-1/4" L	

Re	3.7	Ohms	BL	7.9	TM
Sensitivity	93.7	dB	X-max	5	mm
Power	100	watts	Le @ 1kHz	0.52	mH
Fs	31.0	Hz	Frame Ø	203	mm
Qms	1.51		Cutout Ø	183	mm
Qes	0.27		Depth	86	mm
Qts	0.23		Krm	1.324	mΩ
Vas	72.3	Ltrs	Kxm	17.644	mH
Mms	23.7	g	Erm	0.819	
Cms	1111.3	μM/N	Exm	0.596	
Sd	0.0214	M <sup>2</sup>	Box Rec.:	15 liters, 2" Ø V x 3.75" L	

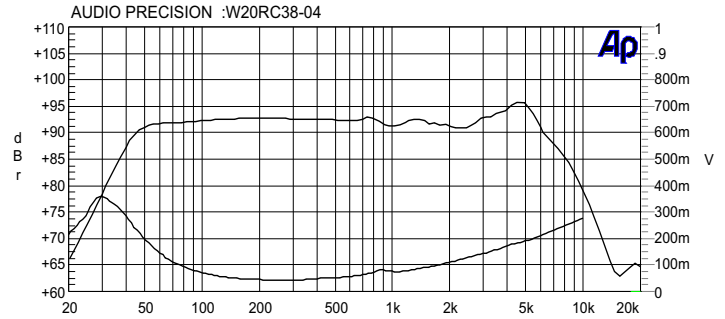
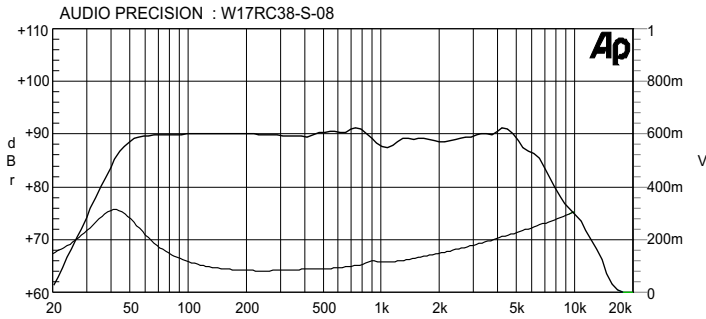

**W20RC38-08 \$31.20**

**Silver Flute**



- 8"
- Wool Cone
- Cast Frame
- 38mm VC Ø
- Rubber Surround
- Vented Pole Piece
- F3 of 60Hz in 0.64 ft<sup>3</sup> vented enclosure

**W20RC38-S-08 \$38.95**

**Silver Flute**



- 8"
- Wool Cone
- Cast Frame
- 38mm VC Ø
- Rubber Surround
- **Shielded** magnet
- F3 of 45Hz in 1 ft<sup>3</sup> vented enclosure

Re	7.3	Ohms	BL	10.1	TM
Sensitivity	91	dB	X-max	5	mm
Power	100	watts	Le @ 1kHz	0.92	mH
Fs	30.8	Hz	Frame Ø	203	mm
Qms	1.30		Cutout Ø	183	mm
Qes	0.28		Depth	86	mm
Qts	0.23		Krm	1.65	mΩ
Vas	83.3	Ltrs	Kxm	32.793	mH
Mms	20.9	g	Erm	0.853	
Cms	1281.1	μM/N	Exm	0.591	
Sd	0.0214	M <sup>2</sup>	Box Rec.:	16 ltrs, 2" Ø V x 4" L	

Re	7.3	Ohms	BL	7.57	TM
Sensitivity	88	dB	X-max	5	mm
Power	100	watts	Le @ 1kHz	0.92	mH
Fs	29.5	Hz	Frame Ø	203	mm
Qms	1.81		Cutout Ø	183	mm
Qes	0.53		Depth	103	mm
Qts	0.41		Krm	1.754	mΩ
Vas	84.7	Ltrs	Kxm	25.339	mH
Mms	22.3	g	Erm	0.849	
Cms	1302.1	μM/N	Exm	0.620	
Sd	0.0214	M <sup>2</sup>	Box Rec.:	30 ltrs, 2" Ø V x 3.75" L	

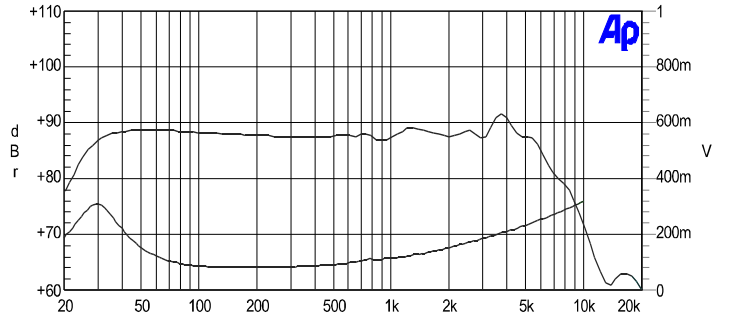
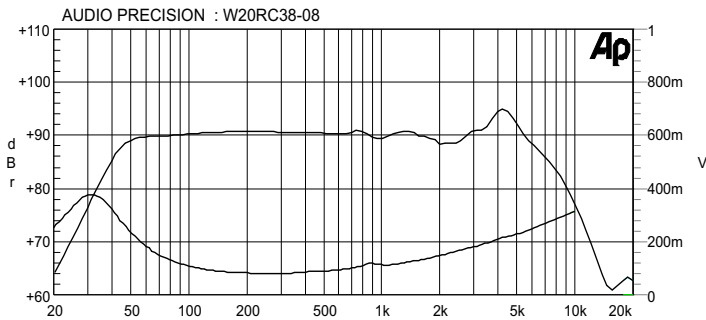



# Skaaning Loudspeakers

Ejvind Skaaning was the founder and guiding force behind the well respected Danish companies of Scanspeak and Dynaudio. Mr. Skaaning's engineering skill and innovative designs are fully expressed in his line of loudspeakers. **Per Skaaning** has joined his father in his work.

We have chosen three speakers from the line that should provide fulfill the needs of many different possible designs. We can assist you in enclosure designs and crossover calculations.

**SK300-304DVC Dual voice coil version is \$710.00 each.**



**SK130-308 C-Quenze (18H522006SD)**



**SK170-308 (6A771020SD)**



**SK300-304 (12B7730104)**

Technical Data	Symbol	SK130-308	SK170-308	SK300-304	Unit
Nominal Impedance	Z	8	8	4	$\Omega$
Resonance Frequency	Fs	25.8	37	18.38	Hz
Power Handling Nominal	P	150	200	350	W
Sensitivity (1W/1m)	E	90	90	91	dB
Voice coil Diameter	$\emptyset$	52	77	77	mm
DC Resistance	Re	4.7	5.49	3.4	$\Omega$
Voice Coil Inductance	Lbm	0.313	0.243	0.557	mH
Voice Coil Length	h	20	10	30	mm
Former	Aluminum				
Wire	Hexagonal Aluminum				
Number of Layers	n	2	2	2	
Cast Aluminum Basket		7 1/8" $\emptyset$	8 7/8" $\emptyset$	13 3/16" $\emptyset$	Inches
Cut Out Hole Size		6 1/8" $\emptyset$	7 5/8" $\emptyset$	11 15/16" $\emptyset$	Inches
Depth from back of flange		3 3/16"	3 15/16"	5 7/8"	Inches
Cone Material	Mineral Filled Polypropylene				
Surround Material	Rubber				
Force Factor	BL	6.4939	7.4737	9.5235	NA <sup>-1</sup>
Height of Magnet Gap	He	6	20	10	mm
Linear Excursion peak	Xmax	7	5 Underhung	10	mm
Suspension Compliance	Cms	2870.18	1161.44	1052.72	$\mu\text{mN}^{-1}$
Mechanical Q Factor	Qms	1.252	1.704	1.722	-
Electrical Q Factor	Qes	0.239	0.365	0.308	-
Total Q Factor	Qts	0.201	0.300	0.262	-
Moving Mass	Mms	13.25	15.98	71.24	g
Effective Piston Area	Sd	0.0137	0.017	0.0515	m <sup>2</sup>
Equivalent Air Volume	Vas	76.50	47.66	396.48	Ltrs
Leap Motor Constants	Krm	33.857	160.172	4.037	m $\Omega$
	Kxm	216.084	448.881	31.023	mH
	Erm	0.469	0.308	0.720	
	Exm	0.253	0.140	0.540	
<b>Price Each</b>		<b>\$330.00</b>	<b>\$511.00</b>	<b>\$680.00</b>	

**SK130-308 C-Quenze (18H52 20 06 SD)**

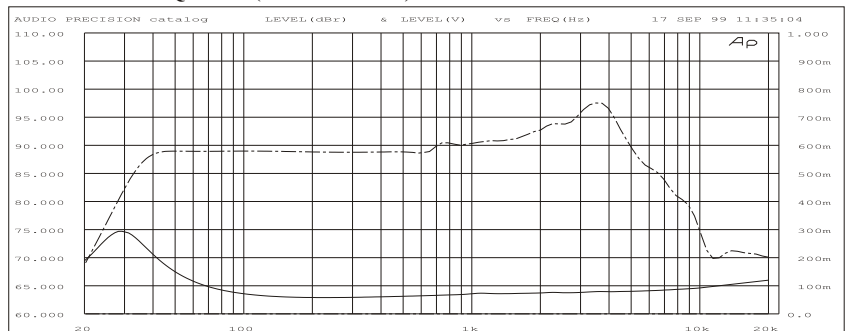

**SK170-308 Flex Unit (6A77 10 20 SD)**

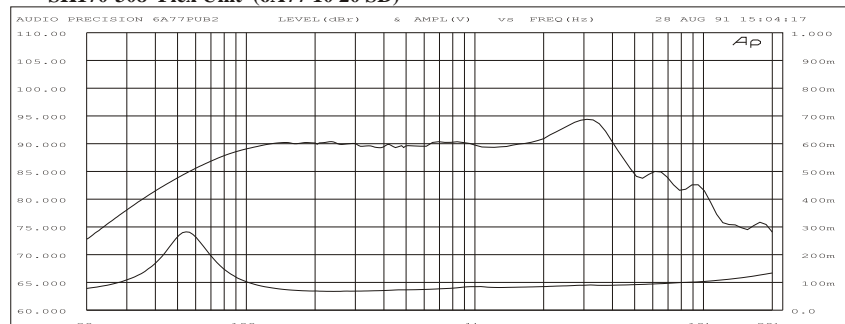

# SONICRAFT

## 12" High Performance Subwoofers



Sonicraft subwoofers have been carefully designed, using the best materials, to provide realistic and tight bass reproduction. The SC1250 in a sealed box will balance well with any audio or video system, without seeming boomy.

The SC12NRT is constructed with an Aurasound NRT motor for maximum excursion. This is the woofer you need to shake the house down. This driver has extreme excursion, yet remains tight and accurate. Perfect for any situation, Home Theater, Audio or Autosound.

### Sonicraft SC-1250 Specifications

Fs	18.9Hz
Nom. Impedance	4 ohm
Mmd	81.35 Grams
Cms	804.25 $\mu\text{m/n}$
Vas	292.4 Liters
Rsc	3.4 $\Omega$
vcL	1.04 mH @ 1K
Bl	8.404 Tm
Qms	4.868
Qes	0.503
Qts	0.456
VC Height	34 mm
AG Height	8 mm
Xmax	13.0 mm Peak
SD	0.0506 m <sup>2</sup>
Leap Krm	2.682 m $\Omega$
Leap Kxm	14.734 mH
Leap Erm	0.802
Leap Exm	0.697
Surround	SBR Rubber
Cone Material	Coated Pulp Paper
Magnet	50 oz.
Voice Coil	2 inch
Music Power	300 Watts
Sensitivity	91 dB 2.83V/1m
Outside diameter	310 mm (12.2")
Cutout diameter	283 mm (11.15")
Depth	160 mm (6.3")
<b>Sale Price</b>	<b>\$95.00</b>

### SC-1250 12" Woofer

- Cast Frame
- Coated Pulp Paper Cone
- SBR High Roll Rubber Surround
- Conex Fiber Spider
- Vented T-Yoke with Heat Sinks, extended pole piece
- Vented Top Plate
- Kapton VC Former
- Gold Plated Terminals
- Decorative Logo

### SC12NRT 12" Woofer

- Rigid Cast Frame
- Layered Poly Cone
- Extra Long Stroke Foam surround
- Underhung Voice Coil
- Conex Fiber Spider
- NRT Neodymium motor with huge rear vent
- Gold Plated Binding Posts
- Kapton Voice Coil Former
- Low Distortion

### Sonicraft SC12NRT Specifications

Fs	23.7Hz
Nom. Impedance	4 ohm
Mmd	131.3 Grams
Cms	329.38 $\mu\text{M/N}$
Vas	97.69 Liters
Rsc	3.70 $\Omega$
vcL	1.277 mH @ 1K
Bl	12.07 Tm
Qms	9.627
Qes	0.517
Qts	0.491
VC Height	20 mm
Magnet Height	38.1 mm
Xmax	15 mm
SD	0.0457 m <sup>2</sup>
Leap Krm	6.974 m $\Omega$
Leap Kxm	35.814 mH
Leap Erm	0.749
Leap Exm	0.619
Surround	ELS Foam
Cone Material	Polypropylene
Magnet	NRT Neodymium
Voice Coil $\emptyset$	3 inch
Music Power	300 Watts
Sensitivity	88.5 dB 2.83V/1m
Outside Diameter	310 mm (12.2")
Cutout Diameter	283 mm (11.2")
Depth	155 mm (6.1")
<b>Sale Price</b>	<b>\$159.00</b>

#### SC-1250 Suggested Alignments:

A 3.5 cubic foot sealed and stuffed enclosure will have a 3dB down point of 30Hz and a Qtc of about 0.8. A lower Qtc can be achieved in a larger enclosure. When used with one of our amplifiers the F3 will be about 25Hz.

This driver in a 3.5 cubic sealed box mounted in a sedan sized car will have a 5dB boost from 20Hz to 75Hz.

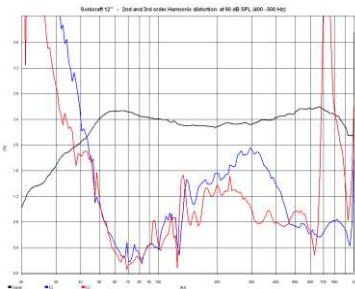

#### SC12NRT Box Alignments:

A 3 cubic foot vented enclosure would have a 3dB down point of 25Hz. This box would need a 3" diameter vent by 12" long.

A 2.7 cubic foot sealed box has an F3 of 35Hz. You could use this driver in our NHT cabinet.

If you use one of our Keiga subwoofer amplifiers, the built in boost at 25Hz will push these F3's lower by at least 5 Hz.

Madisound Speaker Components, Inc.

P.O. Box 44283, (8608 University Green #10) Madison, WI 53744-4283

Tel:608-831-3433

Fax:608-831-3771

email: info@madisound.com

www.madisound.com

# The Swan 305 Woofer

Swan 305 Specifications	
Fs	22.7
Impedance	8
Mmd	110.4 Grams
Cms	415.7 m/n
Vas	166.5 Liters
Rsc	5.2
Leap Krm	5.798 m
Leap Kxm	27.301 mH
Leap Erm	0.834
Leap Exm	0.775
vcL	3.82mH @ 1K
Bl	14.74 Tm
Qms	9.654
Qes	0.401
Qts	0.385
Xmax	7.3 mm Peak
SD	0.0531 m <sup>2</sup>
Surround	Foam
Magnet	40 oz.
Voice Coil	2 Inch
Power Handling	200 watts
Freq. Response	25—1500 Hz
Efficiency	90 dB @2.83V
Uses	Home Hi-Fi, Auto
<b>Price</b>	<b>\$58.00</b>



Swan 305 Suggested Alignments				
Box Volume	56 Liter	70 Liter	90 Liter	120 Liter
Bass 1W /1m F3	42 Hz	32 Hz	28 Hz	25 Hz
Box Vent Freq. Fb	Sealed	24 Hz	24 Hz	24 Hz
Port Diameter		3	3	3
Inches				
Port Length		11	8.2	5.6
Inches				

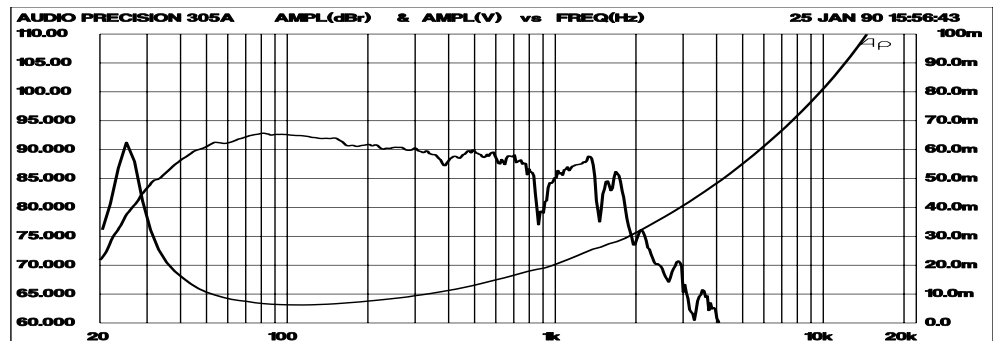
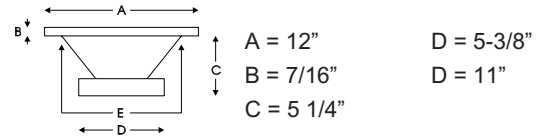

## Eclipse Woofers by Eminence

Eclipse 10" Polypropylene cone woofer with rubber surround and vented pole piece.

Eclipse 12" Polypropylene cone woofer with rubber surround and vented pole piece.

W1038R 10" Poly Cone Woofer	
Fs	18.36
Impedance	6 ohm
Mmd	58.4 Grams
Cms	1207.4 m/n
Vas	214.9 Liters
Rsc	4.7
Leap Krm	3.439
Leap Kxm	25.412
Leap Erm	0.813
Leap Exm	0.670
vcL	1.4mH @ 1K
Bl	9.95 Tm
Qms	4.694
Qes	0.341
Qts	0.318
Xmax	8.0 mm Peak
SD	0.0354 m <sup>2</sup>
Surround	Rubber
Magnet	40 oz.
Voice Coil	2 Inch
Power Handling	100 watts
Freq. Response	28—1500 Hz
Efficiency	88 dB @2.83V
<b>Price</b>	<b>\$57.00</b>



**Frame Size:**  
 10 1/8" diameter  
 9 1/8" cutout diameter  
 4 7/16" depth

**Sealed Box Alignment**  
 2 cubic feet  
 F3 of 40Hz  
 Qtc of .7

**Vented Box Alignments**  
 QB3 alignment  
 2.9 cubic feet  
 F3 of 28Hz  
 3" diameter x 9" long

W1238R 12" Poly Cone Woofer	
Fs	21.48
Impedance	6 ohm
Mmd	86.5 Grams
Cms	586.39 m/n
Vas	236.55 Liters
Rsc	4.9
Leap Krm	3.368
Leap Kxm	28.125
Leap Erm	0.868
Leap Exm	0.738
vcL	2.84mH @ 1K
Bl	15.38 Tm
Qms	6.599
Qes	0.262
Qts	0.252
Xmax	8.0 mm Peak
SD	0.0533 m <sup>2</sup>
Surround	Rubber
Magnet	40 oz.
Voice Coil	2 Inch
Power Handling	150 watts
Freq. Response	25—1000 Hz
Efficiency	92 dB @2.83V
<b>Price</b>	<b>\$61.00</b>



**Frame Size:**  
 12" diameter  
 11" cutout diameter  
 5 3/8" depth

**Vented Box Alignment**  
 2.0 cubic feet  
 F3 of 35Hz  
 3" diameter x 6" long  
 w/KG5150 F3 30Hz

This speaker should be a good choice for a small powerful subwoofer.



Model #	Description	Ω	Price
<b>V-Line "XT" High Performance Speakers</b>			
XT19TD00	¾" Ring Radiator tweeter	4	\$39.40
XT25SC30	<b>Shielded</b> Ring Radiator discontinued	4	\$55.45
XT25SC50	Small Shielded 1" ring radiator	4	\$33.40
XT25TG30	1" Ring Radiator tweeter	4	\$48.20
XG18WH00	7" Fiberglass cone mid/bass	8	\$62.95
XT18WH09	7" Wood fiber cone mid/bass	8	\$70.80
XT18WO09	7" Wood fiber cone mid/bass	8	\$82.00
<b>V-Line "PL" Premium Speakers</b>			
DX25TG05	1" Fabric dome tweeter	4	\$27.75
D75MX41	3" Fabric dome midrange	8	\$76.05
PL11MH09	4 1/2" Paper cone midrange	8	\$54.90
PL11WG09	4 ½" Paper cone mid/bass	4/8	\$47.35
PL11WH09	4 ½" Paper cone mid/bass	4/8	\$54.00
PL14WJ09	5 ½" Paper cone mid/bass	4/8	\$64.55
PL18WO09	7" Paper cone mid/bass	4/8	\$76.05
PL22WR09	8" Paper cone woofer	4/8	\$97.45
PL26WR09	10" Paper cone woofer	4/8	\$107.90
<b>V-Line TG Series Full Range Glass Fiber Cones</b>			
TG9FD10	3.5" Full Range	4	\$29.50
TG9FSD10	Shielded 3.5" Full Range	4	\$33.95
<b>All Items Below and in the opposite column are discontinued.</b>			
<b>Vifa "MG" Tweeters &amp; Fiberglass Cone Woofers (discontinued)</b>			
DX19SD05	<b>Shielded</b> ¾" Fabric dome tweeter	4	\$27.90
DX19TD05	¾" Fabric dome tweeter	4	\$23.20
DX25SG05	<b>Shielded</b> 1" Fabric dome tweeter	4	\$28.00
MG27SG29	<b>Shielded</b> 1" Fabric dome tweeter	4	\$28.80
MG27TG29	1" Fabric dome tweeter	4	\$22.10
MG27TG39	1" Fabric dome tweeter, chambered	4	\$26.40
MG10SD09	<b>Shielded</b> 4" Fiberglass midrange	4/8	\$44.50
MG10MD09	4" Fiberglass cone midrange	4/8	\$43.10
MG14SK09	<b>Shielded</b> 5 ½" Fiberglass mid/bass	4/8	\$54.50
MG14WK09	5 ½" Fiberglass cone mid/bass	4/8	\$43.60
MG18SK09	<b>Shielded</b> 7" Fiberglass mid/bass	4/8	\$54.70
MG18WK09	7" Fiberglass mid/bass	4	\$44.95
MG22WO09	8" Fiberglass cone woofer	4/8	\$62.85
<b>Vifa "TC" Tweeters &amp; Paper Cone Woofers (discontinued)</b>			
TC20SD05	<b>Shielded</b> ¾" Fabric dome tweeter	6	\$19.25
TC20TD05	¾" Fabric dome tweeter	6	\$15.30
TC26SF05	<b>Shielded</b> 1" Fabric dome tweeter	6	\$24.55
TC26TG05	1" Fabric dome tweeter	6	\$19.05
TC08SD49	<b>Shielded</b> 3" Paper cone mid/bass	8	\$28.85
TC11SG49	<b>Shielded</b> 4 ½" Paper cone mid/bass	4/8	\$30.80
TC11WG49	4 ½" Paper cone mid/bass	4/8	\$25.20
TC14SG49	<b>Shielded</b> 5 ½" Paper cone mid/bass	4/8	\$29.15
TC14WG49	5 ½" Paper cone mid/bass	8	\$24.40
TC18SG49	<b>Shielded</b> 7" Paper cone mid/bass	8	\$31.05
TC18WG49	7" Paper cone mid/bass	8	\$26.30
<b>Vifa "Classic" Tweeters (discontinued)</b>			
D19TD05	¾" Polymer dome tweeter	8	\$15.20
D20TD05	¾" Fabric dome tweeter	6	\$16.45
D25ASG05	<b>Shielded</b> 1" Aluminum tweeter	6	\$32.95
D25AG05	1" Aluminum dome tweeter	6	\$27.60
D25AG35	1" Aluminum dome, chambered	6	\$33.85
D26TG05	1" Fabric dome tweeter	6	\$21.70

Model #	Description	Ω	Price
D26TG35	1" Fabric dome tweeter, chambered	6	\$28.15
D27SG05	<b>Shielded</b> 1" Fabric dome tweeter	6	\$28.15
D27TG05	1" Fabric dome tweeter	6	\$21.90
D27TG35	1" Fabric dome tweeter, chambered	6	\$28.15
D27TG45	1" Fabric dome tweeter, bulged fp	6	\$28.25
H26TG35	Horn 1" Fabric dome tweeter	6	\$30.35
D26NC55	1" Fabric dome neo., w/heat sinks	6	\$28.90
<b>Vifa "Classic" Midranges (discontinued)</b>			
M10MD39	3" Paper cone midrange	8	\$30.90
P13MH00	5" Poly cone midrange	8	\$43.75
<b>Vifa "Classic" Mid/Bass &amp; Woofers (discontinued)</b>			
C11WG09	4 ½" Paper cone mid/bass	4/8	\$27.80
C13WG08	5.25" paper cone mid/bass	8	\$29.30
M13SG09	<b>Shielded</b> 5" Paper cone mid/bass	8/16	\$42.00
P13WG00	5" Poly cone mid/bass	8	\$39.00
P13WH00	5" Poly cone mid/bass	8	\$43.75
M17SG09	<b>Shielded</b> 6.5" Paper cone mid/bass	8	\$45.15
P17SJ00	<b>Shielded</b> 6.5" Poly cone mid/bass	8	\$58.60
P17WJ00	6.5" Poly cone mid/bass	4/8	\$45.20
C17WG69	6.5" Paper cone mid/bass	8	\$25.20
M18WO09	7" Paper cone woofer	8	\$62.10
M21WO39	8" Paper cone woofer	8	\$63.90
P21WO20	8" Poly cone woofer	8	\$63.30
P21WO39	8" Poly cone woofer	8	\$64.80
M22WR09	8" Paper cone woofer	8	\$91.15
MA26WR09	10" Black Aluminum cone woofer	4	\$133.50
M26WR09	10" Paper cone woofer	8	\$99.10
<b>Vifa "Classic" Autosound (discontinued)</b>			
D25AC05	1" Aluminum dome, neo., grill	6	\$29.20
D26NC05	1" Fabric dome, neo., grill	6	\$28.50
P13WH10	5" Poly cone mid/bass	4	\$43.75
M18WN19	7" Paper cone mid/bass, no grill	4	\$59.40
VTG	Grill for 4 hole 104mm tweeters	pr	\$9.00
V6G	Grill for 17cm mid/bass ( <b>not 18cm</b> )	pr	\$14.00
V8G	Grill for 21cm mid/bass ( <b>not 22cm</b> )	pr	\$17.00
VFM	Flush mount kit; D25AC/D26NC	ea	\$3.10
VWM	Wedge mount kit; D25AC/D26NC	ea	\$2.35
<b>New Vifa Autosound (discontinued)</b>			
A10CG09	4" Coaxial speaker	4	\$56.80
A10WG09	4" woofer	4	\$27.00
A13CG09	5" Coaxial speaker	4	\$61.55
A13WG09	5" woofer	4	\$28.75
A16CG09	6.5" Coaxial speaker	4	\$66.70
A16WG09	6.5" woofer	4	\$31.00
MA26WR09	10" Black Aluminum cone woofer	4	\$133.50

Tymphany has recently made some changes to the Vifa line. The Vifa name has been retired and is now called the Peerless V-Line. Many older Vifa units are being retired and the current line consists of the XT and PL platforms. All new driver expansion will be in the Peerless line.

We have stocked up on many older Vifa units, but this will be the last. Buy your replacement drivers now! No repair parts will be offered, this is it, final!



## XT19TD00-04



- 19mm Dual concentric diaphragm
- Non-reflective dual chamber
- Controlled directivity
- Wave-guide center plug
- copper-clad aluwire VC
- Flange 94mm
- Cutout 68.5mm

Znom	4 ohm	BL	1.7 Tm
Re	2.9 ohm	Vas	- ltrs
Le@1kHz	mH	Xmax	0.35 mm peak
fs	681.9 Hz	VC Ø	19 mm
Qms	2.39	Sensitivity	
Qes	0.82	2.83V / 1m	89 dB
Qts	0.61	Nom. Power DIN	W
Mms	0.20 g	Magnet weight	g
Sd	4.55 cm <sup>2</sup>		

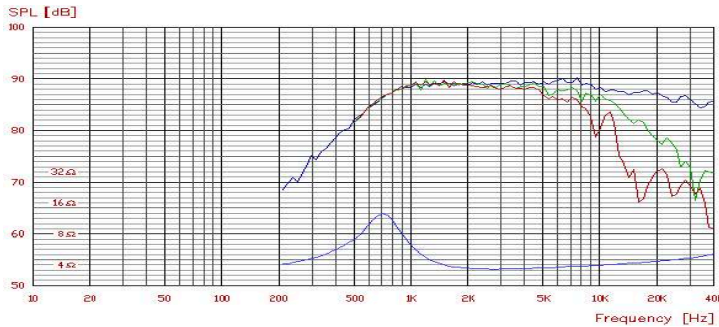

## XT25SC30-04



Discontinued, still in stock.

- 25mm Dual concentric diaphragm
- Non-reflective dual chamber
- Controlled directivity
- Wave-guide center plug
- copper-clad aluwire VC
- Neodymium magnet
- Flange 104mm
- Cutout 73.5mm, D 49mm

Znom	4 ohm	Sd	5.4 cm <sup>2</sup>
Re	3.0 ohm	BL	Tm
Le@1kHz	mH	Vas	- ltrs
fs	680 Hz	Xmax	- mm peak
Qms	-	VC Ø	25 mm
Qes	-	Sensitivity	
Qts	-	2.83V / 1m	89 dB
Mms	0.30 g	Nom. Power DIN	W
(Specs & Curves by Madisound)		Magnet weight	g

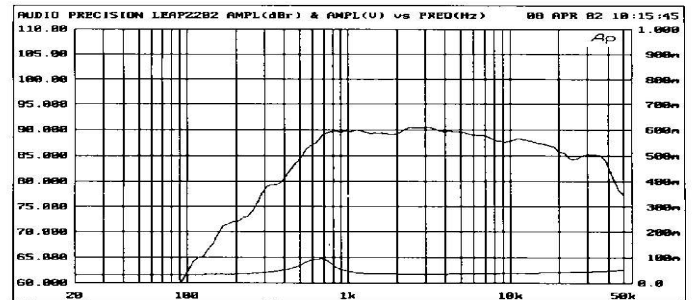

## XT25SC50-04



- 25mm Dual concentric diaphragm
- Ring formed chamber
- Controlled directivity
- Heat sink on magnet
- Gasket
- Wave-guide center plug
- Neodymium magnet
- Flange 65mm
- Cutout 46.2mm, D 21mm

Znom	4 ohm	Sd	6.0 cm <sup>2</sup>
Re	3.1 ohm	BL	2.3 Tm
Le@1kHz	0.04 mH	Vas	- ltrs
fs	950 Hz	Xmax	0.5 mm peak
Qms	-	VC Ø	25 mm
Qes	-	Sensitivity	
Qts	-	2.83V / 1m	92.5 dB
Mms	.30 g	Nom. Power DIN	80 W
Cms	- mm/N	Magnet weight	g

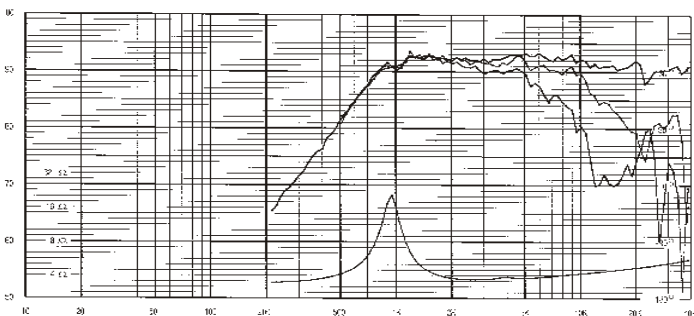

## XT25TG30-04



- 25mm Dual concentric diaphragm
- Non-reflective dual chamber
- Controlled directivity
- Wave-guide center plug
- copper-clad aluwire VC and braided leads
- Flange 104mm
- Cutout 73.5mm, D 41mm

Znom	4 ohm	Sd	5.4 cm <sup>2</sup>
Re	3.0 ohm	BL	2.5 Tm
Le@1kHz	- mH	Vas	0.02 ltrs
fs	500 Hz	Xmax	0.5 mm peak
Qms	2.50	VC Ø	25 mm
Qes	0.71	Sensitivity	
Qts	0.55	2.83V / 1m	91.5 dB
Mms	.30 g	Nom. Power DIN	140 W
Cms	- mm/N	Magnet weight	240 g

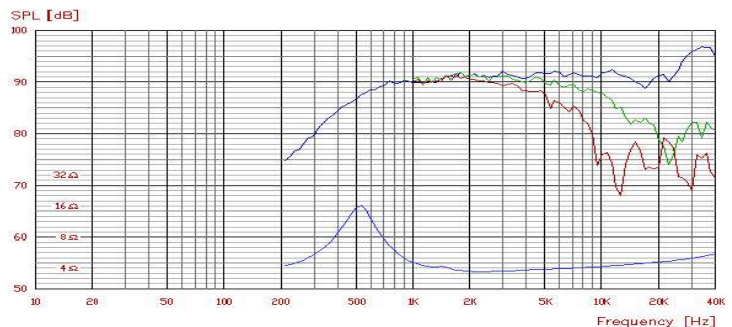



## XG18WH00-08



- 7" Glass fiber cone mid-woofer
- Phase integrated dust cap
- Low resonance multi-roll surround
- Airflow optimized low distortion chassis and magnet system
- Flange 180mm
- Special installation inst.

Znom	8 ohm	Sd	129 cm <sup>2</sup>
Re	5.7 ohm	BL	5.6 Tm
Le@1kHz	0.53 mH	Vas	45 ltrs
fs	34 Hz	Xmax	5 mm peak
Qms	1.77	VC Ø	25 mm
Qes	0.46	Sensitivity	
Qts	0.36	2.83V / 1m	86 dB
Mms	11.8 g	Nom. Power DIN	- W
Rm	1.4 Ns/m	Magnet weight	415 g

## XT18WH09-08



- 7" Wood fiber cone mid-woofer
- Phase integrated dust cap
- Low resonance multi-roll surround
- Airflow optimized low distortion chassis and magnet system
- Flange 180mm
- Special installation inst.

Znom	8 ohm	Sd	129 cm <sup>2</sup>
Re	5.5 ohm	BL	5.5 Tm
Le@1kHz	0.54 mH	Vas	39 ltrs
fs	38 Hz	Xmax	5 mm peak
Qms	1.83	VC Ø	25 mm
Qes	0.46	Sensitivity	
Qts	0.37	2.83V / 1m	87 dB
Mms	10.7 g	Nom. Power DIN	- W
Rm	1.4 Ns/m	Magnet weight	415 g

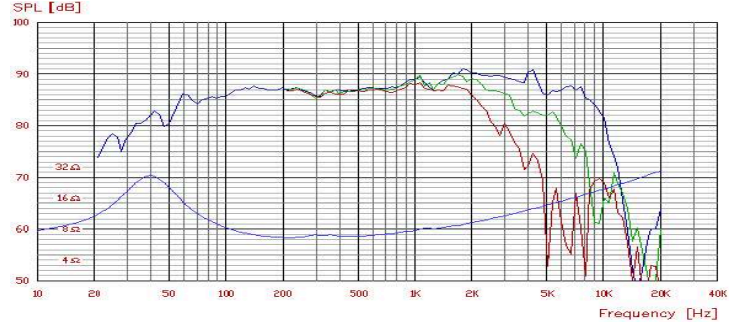
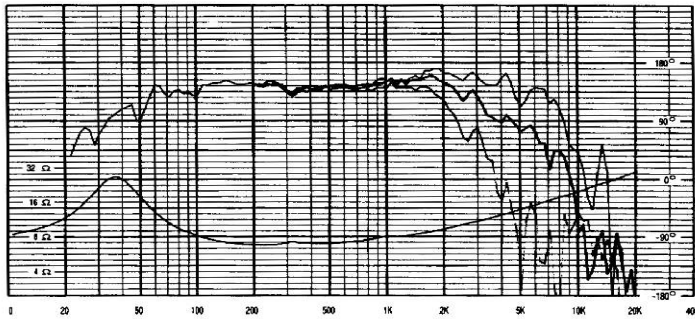

## XT18WO09-08



- 7" Wood fiber cone mid-woofer
- Phase integrated dust cap
- Low resonance multi-roll surround
- Airflow optimized low distortion chassis and magnet system
- Flange 180mm
- Special installation inst.

Znom	8 ohm	Sd	129 cm <sup>2</sup>
Re	5.8 ohm	BL	6.2 Tm
Le@1kHz	0.54 mH	Vas	38 ltrs
fs	38 Hz	Xmax	4.5 mm peak
Qms	5.87	VC Ø	25 mm
Qes	0.39	Sensitivity	
Qts	0.37	2.83V / 1m	88 dB
Mms	11.1 g	Nom. Power DIN	- W
Rm	0.43 Ns/m	Magnet weight	698 g

## DX25TG05-04



- 1" Fabric high dispersion dome tweeter
- Low compression chamber design
- Light weight voice coil
- High power handling
- High Sensitivity
- Flange 104mm
- Cut-out 75mm
- Depth 26mm

Znom	4 ohm	Sd	7.0 cm <sup>2</sup>
Re	2.75 ohm	BL	2.2 Tm
Le@1kHz	mH	Vas	- ltrs
fs	650 Hz	Xmax	- mm peak
Qms	4.32	VC Ø	25 mm
Qes	0.79	Sensitivity	
Qts	0.67	2.83V / 1m	93.5 dB
Mms	0.42 g	Nom. Power DIN	- W
Cms	- mm/N	Magnet weight	240 g

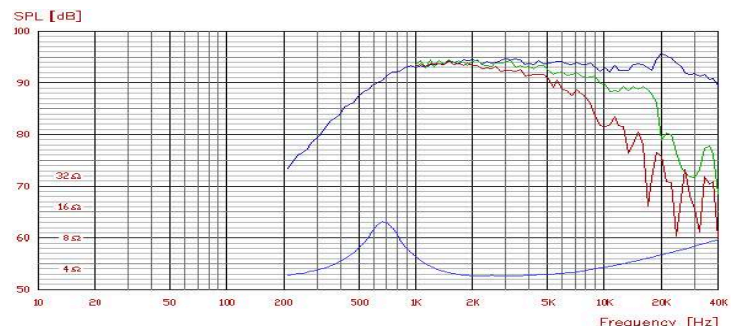
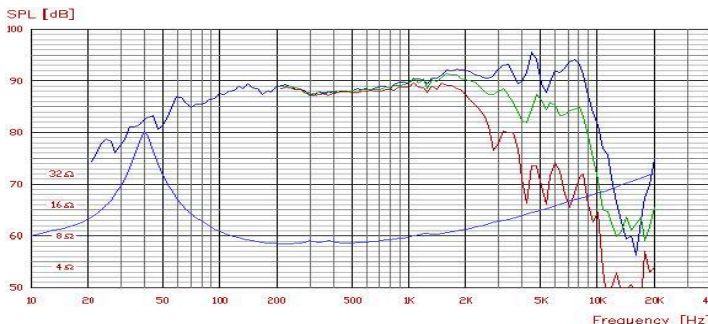

## D75MX-41-08



- 3" dome midrange
- Precoated fabric diaphragm
- Low moving mass
- Internal ferrite magnet
- Very linear impedance
- Flange 152mm
- Cutout 120.7mm
- Depth 31.5mm

Znom	8 ohm	Sd	55 cm <sup>2</sup>
Re	5.9 ohm	BL	4.7 Tm
Le@1kHz	- mH	Vas	- ltrs
fs	350 Hz	Xmax	- mm peak
Qms	-	VC Ø	76 mm
Qes	-	Sensitivity	
Qts	-	2.83V / 1m	92 dB
Mms	3.1 g	Nom. Power DIN	80 W
Cms	- mm/N	Magnet weight	240 g

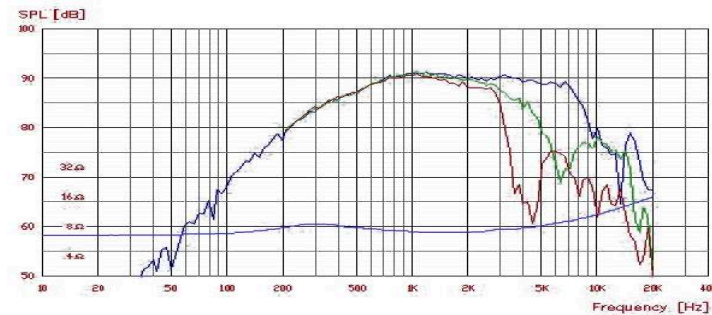

## PL11MH-09-08



- PREMIUM LINE 4.5" midrange
- Non-resonant cone
- Very flat response
- Good off axis response
- Rigid magnesium basket
- Gold plated terminals
- Flange 125mm
- Cut-out 101mm
- Depth 59mm

Znom	8 ohm	Sd	58 cm <sup>2</sup>
Re	5.9 ohm	BL	5.9 Tm
Le@1kHz	.38 mH	Vas	4.25 ltrs
fs	73 Hz	Xmax	1.75 mm peak
Qms	1.65	VC Ø	25 mm
Qes	0.41	Sensitivity	
Qts	0.33	2.83V / 1m	87 dB
Mms	5.3 g	Nom. Power DIN	35 W
Cms	- mm/N	Magnet weight	14.6 oz.

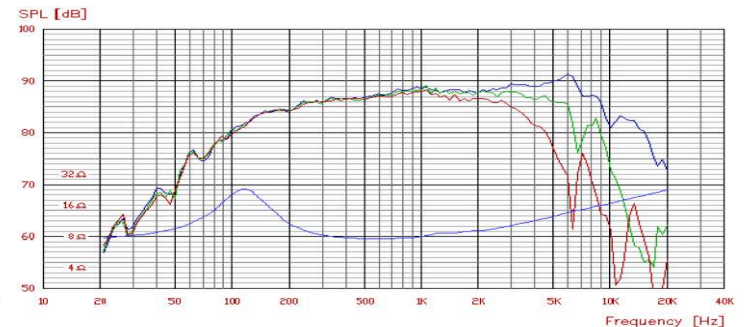

## PL11WG-09-08



- PREMIUM LINE 4.5" mid-woofer
- Non-resonant cone
- Very flat response
- Rigid magnesium basket
- Long linear excursion
- Gold plated terminals
- Flange 125mm
- Cut-out 101mm
- Depth 59mm

Znom	8 ohm	Sd	58 cm <sup>2</sup>
Re	5.6 ohm	BL	4.9 Tm
Le@1kHz	.61 mH	Vas	4.25 ltrs
fs	69 Hz	Xmax	3 mm peak
Qms	2.20	VC Ø	25 mm
Qes	0.60	Sensitivity	
Qts	0.47	2.83V / 1m	85 dB
Mms	5.9 g	Nom. Power DIN	35 W
Cms	-	Magnet weight	8.5 oz.

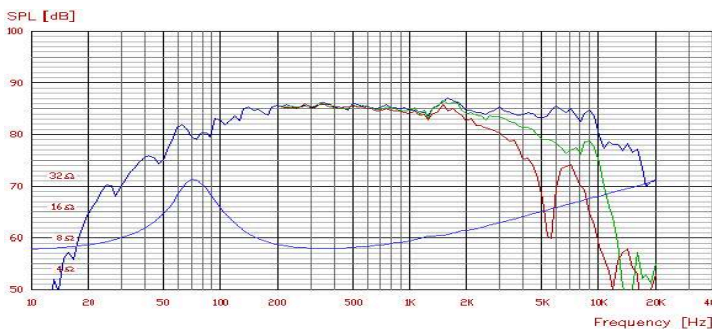

## PL11WH-09-08



- PREMIUM LINE 4.5" mid-woofer
- Non-resonant cone
- Very flat response
- Rigid magnesium basket
- Long linear excursion
- Gold plated terminals
- Flange 125mm
- Cut-out 101mm
- Depth 59mm

Znom	8 ohm	Sd	58 cm <sup>2</sup>
Re	5.6 ohm	BL	6.1 Tm
Le@1kHz	.45 mH	Vas	4.25 ltrs
fs	69 Hz	Xmax	3 mm peak
Qms	1.70	VC Ø	25 mm
Qes	0.39	Sensitivity	
Qts	0.32	2.83V / 1m	87 dB
Mms	5.9 g	Nom. Power DIN	35 W
Cms	-	Magnet weight	16.4 oz.

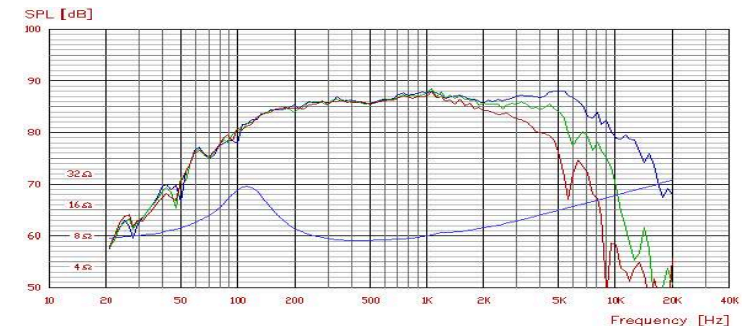



## PL14WJ-09-08



- PREMIUM LINE 5" mid-woofer
- Non-resonant cone
- Very flat response
- Rigid magnesium basket
- Long linear excursion
- Gold plated terminals
- Flange 149mm
- Cut-out 115mm
- Depth 71mm

Znom	8 ohm	Sd	80 cm <sup>2</sup>
Re	5.8 ohm	BL	5.5 Tm
Le@1kHz	.49 mH	Vas	13 ltrs
fs	47 Hz	Xmax	3 mm peak
Qms	2.20	VC Ø	32 mm
Qes	0.46	Sensitivity	
Qts	0.38	2.83V / 1m	86 dB
Mms	8.2 g	Nom. Power DIN	50 W
Cms	- mm/N	Magnet weight	14.5 oz.

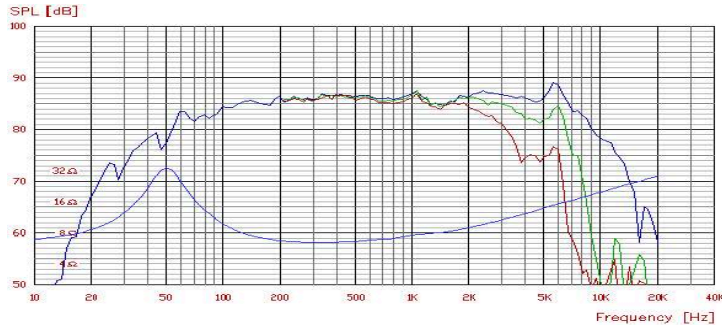

## PL18WO-09-08



- PREMIUM LINE 7" woofer
- Non-resonant cone
- Very flat response
- Rigid magnesium basket
- Long linear excursion
- Gold plated terminals
- Flange 180mm
- Cut-out 145mm
- Depth 84mm

Znom	8 ohm	Sd	132 cm <sup>2</sup>
Re	5.8 ohm	BL	7.8 Tm
Le@1kHz	.85 mH	Vas	25 ltrs
fs	39 Hz	Xmax	4 mm peak
Qms	2.46	VC Ø	40 mm
Qes	0.40	Sensitivity	
Qts	0.34	2.83V / 1m	87 dB
Mms	17.5 g	Nom. Power DIN	100 W
Cms	- mm/N	Magnet weight	24.7 oz

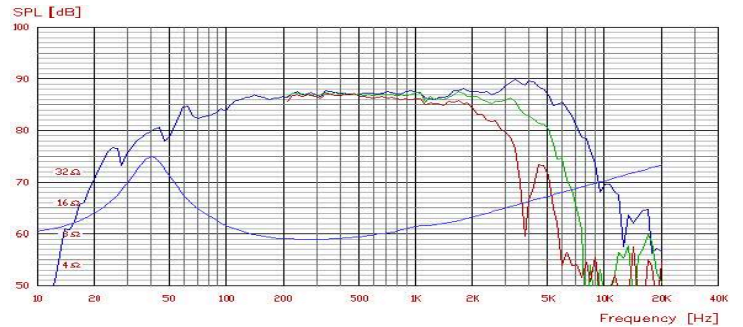

## PL22WR-09-08



- PREMIUM LINE 8" woofer
- Non-resonant cone
- Very flat response
- Rigid magnesium basket
- Long linear excursion
- Gold plated terminals
- Flange 225mm
- Cut-out 185mm
- Depth 99mm

Znom	8 ohm	Sd	224 cm <sup>2</sup>
Re	5.9 ohm	BL	10.9 Tm
Le@1kHz	2.7 mH	Vas	56 ltrs
fs	27 Hz	Xmax	4 mm peak
Qms	5.65	VC Ø	50 mm
Qes	0.37	Sensitivity	
Qts	0.34	2.83V / 1m	85.5 dB
Mms	43 g	Nom. Power DIN	125 W
Cms	- mm/N	Magnet weight	37 oz

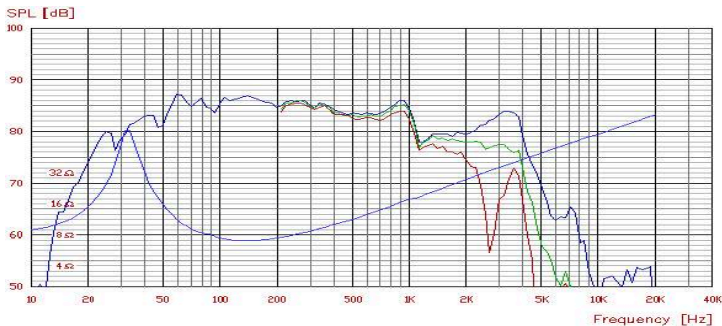

## PL26WR-09-08



- PREMIUM LINE 10" woofer
- Non-resonant cone
- Very flat response
- Rigid magnesium basket
- Long linear excursion
- Gold plated terminals
- Flange 271mm
- Cut-out 232mm
- Depth 107mm

Znom	8 ohm	Sd	337 cm <sup>2</sup>
Re	5.9 ohm	BL	10.9 Tm
Le@1kHz	2.7 mH	Vas	110 ltrs
fs	27 Hz	Xmax	4 mm peak
Qms	4.33	VC Ø	50 mm
Qes	0.43	Sensitivity	
Qts	0.39	2.83V / 1m	87 dB
Mms	51 g	Nom. Power DIN	125 W
Cms	- mm/N	Magnet weight	37 oz

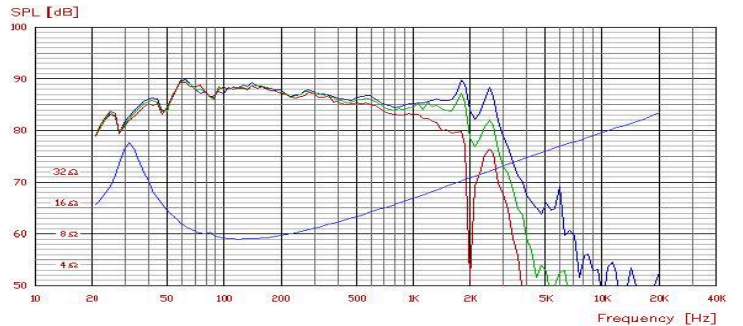



## TG9FD10-04



- 3 1/2" Full Range
- NRSC Glass Fiber Cone
- Copper cap on pole piece
- Polymer Chassis
- Frequency Response 100Hz to 10kHz
- Flange 98mm Square
- Cut-out 78.5mm
- Depth 38mm
- Flange Thickness 3.2mm

Znom	4 ohm	Sd	38 cm <sup>2</sup>
Re	3.2 ohm	BL	2.4 Tm
Le@1kHz	0.12 mH	Vas	3.15 ltrs
fs	82 Hz	Xmax	2.6 mm peak
Qms	2.90	VC Ø	20 mm
Qes	0.70	Sensitivity	
Qts	0.56	2.83V / 1m	85.5 dB
Mms	2.45 g	Nom. Power DIN	- W
Rm	- Ns/m	Magnet weight	105 g

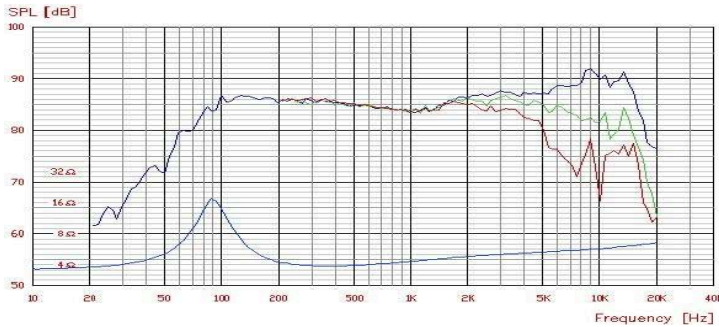

## TG9FSD10-04



- 3 1/2" Full Range
- NRSC Glass Fiber Cone
- Copper cap on pole piece
- Polymer Chassis
- Frequency Response 100Hz to 10kHz
- Flange 98mm Square
- Cut-out 78.5mm
- Depth 38mm
- **Shielded Magnet**

Znom	4 ohm	Sd	38 cm <sup>2</sup>
Re	3.2 ohm	BL	2.4 Tm
Le@1kHz	0.12 mH	Vas	3.15 ltrs
fs	82 Hz	Xmax	2.6 mm peak
Qms	2.90	VC Ø	20 mm
Qes	0.70	Sensitivity	
Qts	0.56	2.83V / 1m	85.5 dB
Mms	2.45 g	Nom. Power DIN	- W
Rm	- Ns/m	Magnet weight	105 g

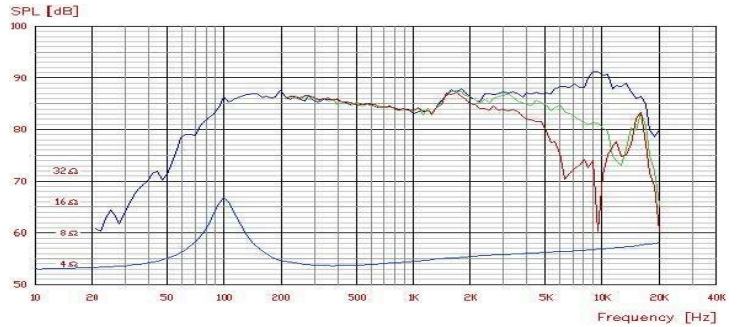

## MG27SG29-04



- 1" **Shielded** Fabric dome tweeter
- Damped chamber & cavity
- Copper clad alu wire
- Ferrofluid cooled
- Gold plated terminals
- Flange 104mm
- Cut-out 79.3mm
- Depth 38.2mm

Znom	4 ohm	Sd	7.1 cm <sup>2</sup>
Re	3.0 ohm	BL	2.5 Tm
Le@1kHz	- mH	Vas	- ltrs
fs	1050 Hz	Xmax	- mm peak
Qms	2.76	VC Ø	25 mm
Qes	0.90	Sensitivity	
Qts	0.68	2.83V / 1m	93.5 dB
Mms	0.28 g	Nom. Power DIN	140 W
Rm	0.67 Ns/m	Magnet weight	140 g

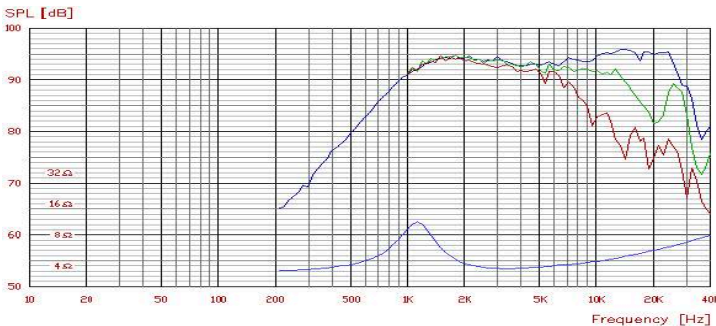

## MG27TG29-04



- 1" Fabric dome tweeter
- Damped cavity
- Copper clad alu wire
- Ferrofluid cooled
- Gold plated terminals
- High power handling
- High sensitivity
- Flange 104mm
- Cut-out 73.5mm
- Depth 24mm

Znom	4 ohm	Sd	7.1 cm <sup>2</sup>
Re	3.0 ohm	BL	2.5 Tm
Le@1kHz	- mH	Vas	- ltrs
fs	1050 Hz	Xmax	- mm peak
Qms	2.76	VC Ø	25 mm
Qes	0.90	Sensitivity	
Qts	0.68	2.83V / 1m	93.5 dB
Mms	0.28 g	Nom. Power DIN	140 W
Rm	0.67 NS/m	Magnet weight	140 g

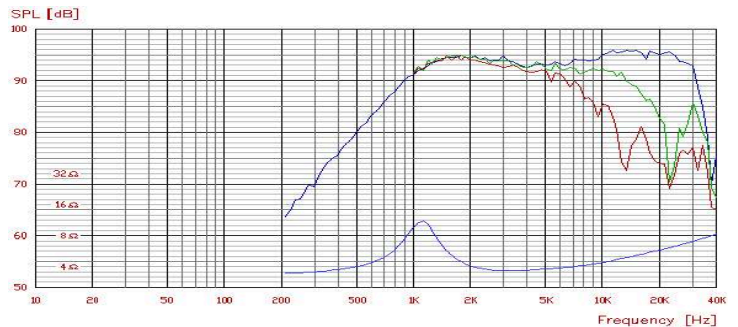

## MG27TG39-04



- 1" Fabric dome tweeter
- Damped chamber & cavity
- Copper clad alu wire
- Ferrofluid cooled
- Gold plated terminals
- High power handling
- Flange 104mm
- Cut-out 73.5mm
- Depth 36.1mm

Znom	4 ohm
Re	3.0 ohm
Le@1kHz	- mH
fs	630 Hz
Qms	0.99
Qes	0.54
Qts	0.35
Mms	0.28 g
Rm	1.12 Ns/m

Sd	7.1 cm <sup>2</sup>
BL	2.5 Tm
Vas	- ltrs
Xmax	- mm peak
VC Ø	25 mm
Sensitivity	2.83V / 1m 95 dB
Nom. Power DIN	140 W
Magnet weight	140 g

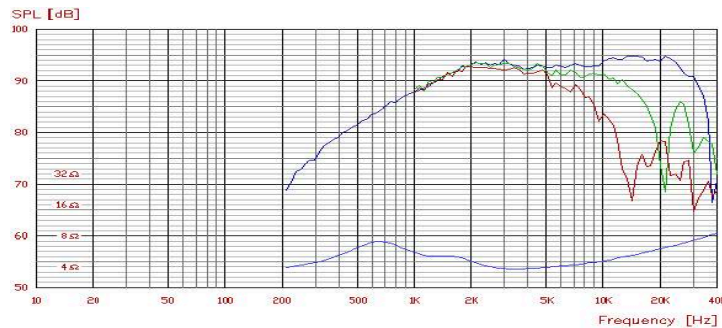

## MG10SD09-08



- 4" Shielded Midrange
- Yellow Glass Fiber cone
- Diecast Chassis
- Low damping rubber surround
- Wide band 100-15000Hz
- Gold plated terminals
- Flange 104mm
- Cut-out 81mm
- Depth 45mm

Znom	8 ohm
Re	5.5 ohm
Le@1kHz	0.33 mH
fs	81 Hz
Qms	3.40
Qes	0.73
Qts	0.60
Mms	3.2 g
Rm	0.48 Ns/m

Sd	38 cm <sup>2</sup>
BL	3.5 Tm
Vas	2.5 ltrs
Xmax	0.65 mm peak
VC Ø	20 mm
Sensitivity	2.83V / 1m 85 dB
Nom. Power DIN	- W
Magnet weight	210 g

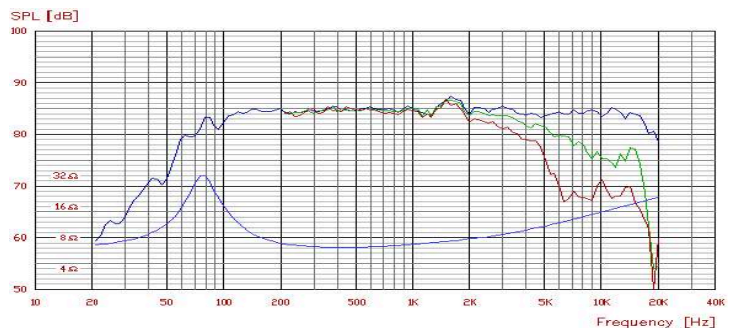

## MG10MD09-08



- 4" Midrange
- Yellow Glass Fiber cone
- Diecast Chassis
- Low damping rubber surround
- Wide band 100-15000Hz
- Gold plated terminals
- Flange 104mm
- Cut-out 81mm
- Depth 44.4mm

Znom	8 ohm
Re	5.5 ohm
Le@1kHz	0.33 mH
fs	81 Hz
Qms	3.40
Qes	0.60
Qts	0.51
Mms	3.2 g
Rm	0.48 Ns/m

Sd	38 cm <sup>2</sup>
BL	3.8 Tm
Vas	2.5 ltrs
Xmax	0.65 mm peak
VC Ø	20 mm
Sensitivity	2.83V / 1m 86 dB
Nom. Power DIN	- W
Magnet weight	210 g

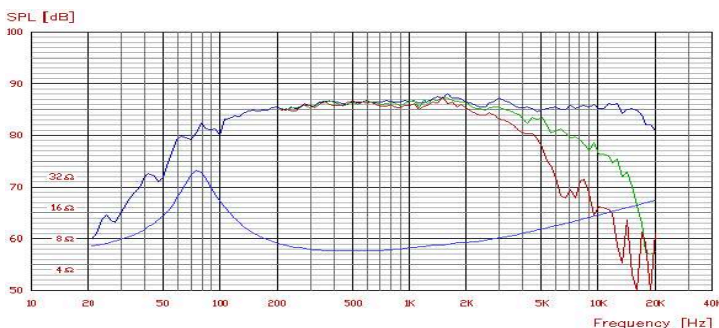

## MG14SK09-08



- 5 1/2" Shielded Woofer
- Yellow Glass Fiber cone
- Diecast Chassis
- Low damping rubber surround
- Low distortion magnet
- Gold plated terminals
- Flange 149mm
- Cut-out 114.7mm
- Depth 78.1

Znom	8 ohm
Re	5.6 ohm
Le@1kHz	0.78 mH
fs	46 Hz
Qms	2.16
Qes	0.36
Qts	0.31
Mms	8.5 g
Rm	1.19 Ns/m

Sd	80 cm <sup>2</sup>
BL	6.3 Tm
Vas	11.7 ltrs
Xmax	3.5 mm peak
VC Ø	25 mm
Sensitivity	2.83V / 1m 87 dB
Nom. Power DIN	60 W
Magnet weight	341 g

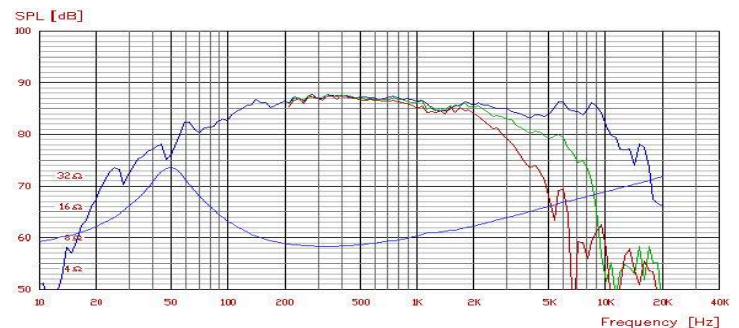



## MG14WK09-08



- 5 1/2" Woofer
- Yellow Glass Fiber cone
- Diecast Chassis
- Low damping rubber surround
- Low distortion magnet
- Gold plated terminals
- Flange 149mm
- Cut-out 114.7mm
- Depth 61.6mm

Znom	8 ohm	Sd	80 cm <sup>2</sup>
Re	5.6 ohm	BL	6.2 Tm
Le@1kHz	0.72 mH	Vas	13.8 ltrs
fs	45 Hz	Xmax	3.5 mm peak
Qms	1.99	VC Ø	25 mm
Qes	0.35	Sensitivity	
Qts	0.30	2.83V / 1m	87 dB
Mms	8.5 g	Nom. Power DIN	60 W
Rm	1.18 Ns/m		

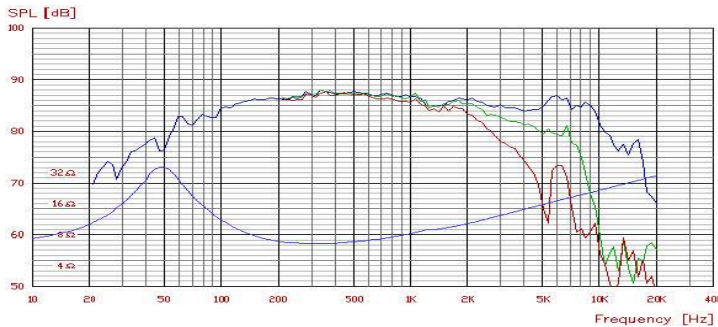

## MG18SK09-08



- 7" Shielded Woofer
- Yellow Glass Fiber cone
- Diecast Chassis
- Low damping rubber surround
- Low distortion magnet
- Gold plated terminals
- Flange 180mm
- Cut-out 145mm
- Depth 89mm

Znom	8 ohm	Sd	138 cm <sup>2</sup>
Re	5.85 ohm	BL	6.22 Tm
Le@1kHz	0.88 mH	Vas	45 ltrs
fs	34 Hz	Xmax	4.65 mm peak
Qms	1.99	VC Ø	25 mm
Qes	0.42	Sensitivity	
Qts	0.35	2.83V / 1m	87 dB
Mms	13 g	Nom. Power DIN	60 W
Rm	1.4 Ns/m		

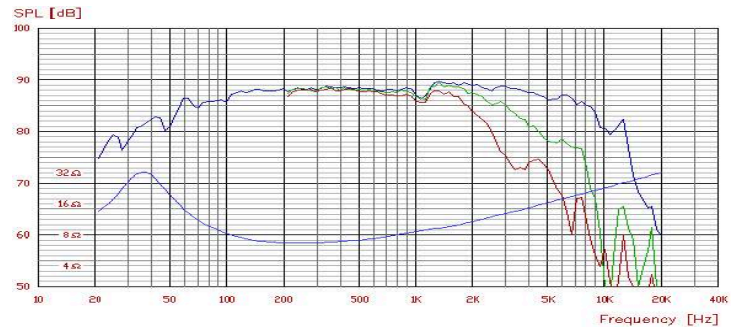

## MG22WO09-08



- 8" Woofer
- Yellow Glass Fiber cone
- Diecast Chassis
- Low damping rubber surround
- Low distortion magnet
- Gold plated terminals
- Flange 225mm
- Cut-out 185.5mm
- Depth 88.7

Znom	8 ohm	Sd	235 cm <sup>2</sup>
Re	5.5 ohm	BL	8.85 Tm
Le@1kHz	1.05 mH	Vas	154 ltrs
fs	21 Hz	Xmax	5.8 mm peak
Qms	1.60	VC Ø	40 mm
Qes	0.27	Sensitivity	
Qts	0.23	2.83V / 1m	88.5 dB
Mms	29 g	Nom. Power DIN	125 W
Cms	2 mm/N	Magnet weight	698 g

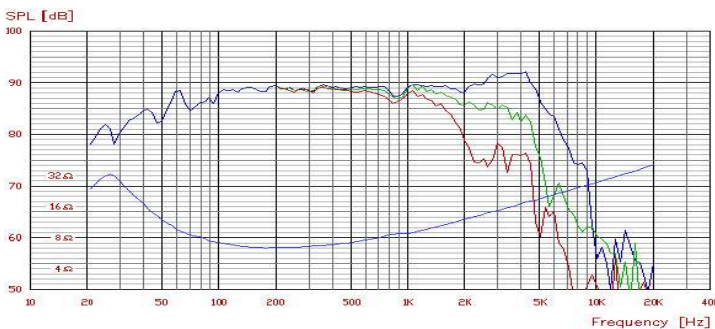

## TC20SD05-06



- 3/4" Shielded Fabric Dome Tweeter
- Linear response faceplate
- Ferrofluid cooled
- Damped pole piece cavity
- Flange 94mm
- Cut-out 72mm
- Depth 30.5

Znom	6 ohm	Sd	4.4 cm <sup>2</sup>
Re	4.2 ohm	BL	1.9 Tm
Le@1kHz	- mH	Vas	- ltrs
fs	1400 Hz	Xmax	0.35 mm peak
Qms	3.30	VC Ø	20 mm
Qes	1.86	Sensitivity	
Qts	1.15	2.83V / 1m	91 dB
Mms	0.2 g	Nom. Power DIN	100 W
Cms	- mm/N	Magnet weight	105 g

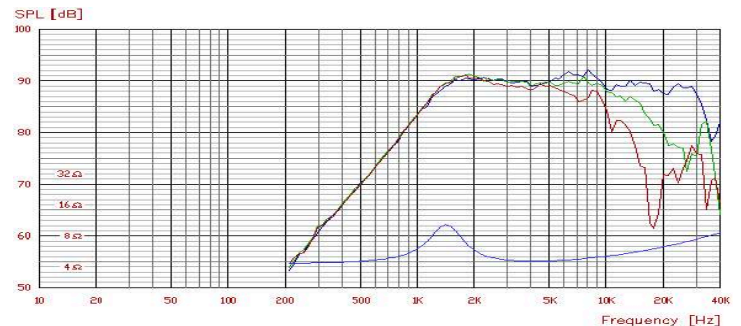



## TC20TD05-06



- 3/4" Fabric Dome Tweeter
- Linear response faceplate
- Ferrofluid cooled
- Damped pole piece cavity
- Flange 94mm
- Cut-out 68mm
- Depth 20mm

Znom	6 ohm	Sd	4.4 cm <sup>2</sup>
Re	4.2 ohm	BL	2.0 Tm
Le@1kHz	- mH	Vas	- ltrs
fs	1400 Hz	Xmax	0.35 mm peak
Qms	3.10	VC Ø	20 mm
Qes	1.76	Sensitivity	
Qts	1.12	2.83V / 1m	90 dB
Mms	0.2 g	Nom. Power DIN	90 W
Cms	- mm/N	Magnet weight	105 g

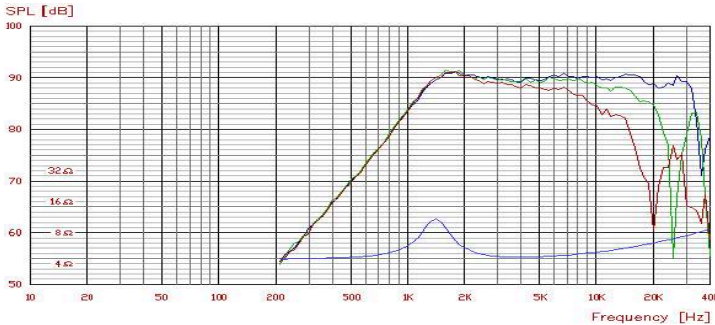

## TC26SF05-06



- 1" Shielded Fabric Dome Tweeter
- Linear response faceplate
- Pole piece cavity
- Magnetically shielded
- Ferrofluid cooled
- Flange 104mm
- Cut-out 82mm
- Depth 31.8mm

Znom	6 ohm	Sd	7.1 cm <sup>2</sup>
Re	4.6 ohm	BL	2.5 Tm
Le@1kHz	- mH	Vas	- ltrs
fs	1200 Hz	Xmax	0.5 mm peak
Qms	2.20	VC Ø	25 mm
Qes	1.83	Sensitivity	
Qts	1.00	2.83V / 1m	91 dB
Mms	0.33 g	Nom. Power DIN	80 W
Cms	- mm/N	Magnet weight	104 g

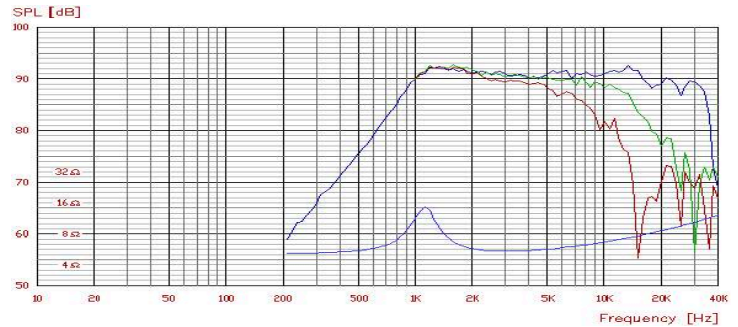

## TC26TG05-06



- 1" Fabric Dome Tweeter
- Linear response faceplate
- High stability ferrofluid
- Damped cavity in pole piece
- Ferrofluid cooled
- Flange 104mm
- Cut-out 82mm
- Depth 27.8mm

Znom	6 ohm	Sd	7.1 cm <sup>2</sup>
Re	4.6 ohm	BL	2.9 Tm
Le@1kHz	- mH	Vas	- ltrs
fs	1150 Hz	Xmax	0.5 mm peak
Qms	2.10	VC Ø	25 mm
Qes	1.30	Sensitivity	
Qts	0.80	2.83V / 1m	92 dB
Mms	0.33 g	Nom. Power DIN	90 W
Cms	- mm/N	Magnet weight	240 g

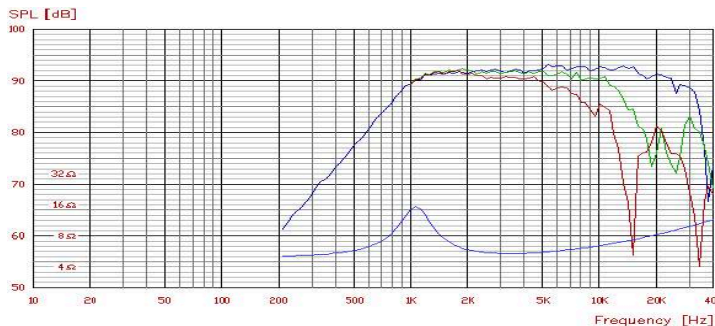

## TC08SD49-08



- 3" Shielded Mid-Woofer
- NRSC coated paper cone
- Rubber surround
- Fibre reinforced polymer chassis
- Vented magnet system
- Flange 95mm
- Cut-out 74.4mm
- Depth 51 mm

Znom	8 ohm	Sd	35 cm <sup>2</sup>
Re	5.45 ohm	BL	3.6 Tm
Le@1kHz	0.47 mH	Vas	1.4 ltrs
fs	100 Hz	Xmax	2 mm peak
Qms	3.52	VC Ø	20 mm
Qes	0.74	Sensitivity	
Qts	0.61	2.83V / 1m	84 dB
Mms	2.8 g	Nom. Power DIN	15 W
Cms	- mm/N	Magnet weight	105 g

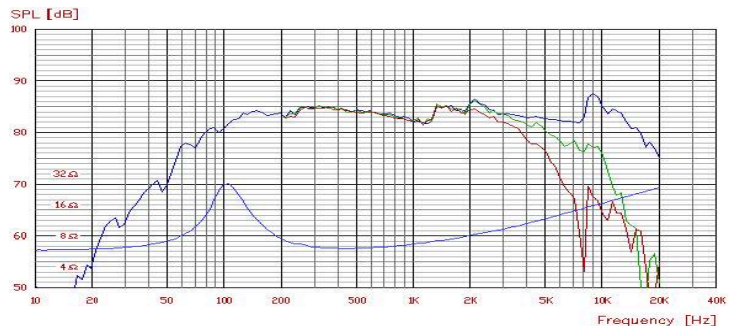

## TC08WD49-08



- 3" Mid-Woofer
- NRSC coated paper cone
- Rubber surround
- Fibre reinforced polymer chassis
- Vented magnet system
- Flange 95mm
- Cut-out 74.4mm
- Depth 40.7mm

Znom	8 ohm	Sd	35 cm <sup>2</sup>
Re	5.45 ohm	BL	3.55 Tm
Le@1kHz	0.47 mH	Vas	1.55 ltrs
fs	100 Hz	Xmax	2 mm peak
Qms	3.52	VC Ø	20 mm
Qes	0.76	Sensitivity	
Qts	0.63	2.83V / 1m	84 dB
Mms	2..8 g	Nom. Power DIN	15 W
Cms	- mm/N	Magnet weight	105 g

## TC11SG49-08



- 4 1/2" Shielded Woofer
- NRSC coated paper cone
- Rubber surround
- Fibre reinforced polymer chassis
- Vented magnet system
- Flange 125mm
- Cut-out 98.2mm
- Depth 64.1mm

Znom	8 ohm	Sd	58 cm <sup>2</sup>
Re	5.55 ohm	BL	5.2 Tm
Le@1kHz	0.60 mH	Vas	6 ltrs
fs	58 Hz	Xmax	3 mm peak
Qms	2.40	VC Ø	25 mm
Qes	0.44	Sensitivity	
Qts	0.37	2.83V / 1m	85 dB
Mms	5.9 g	Nom. Power DIN	20 W
Cms	- mm/N	Magnet weight	240 g

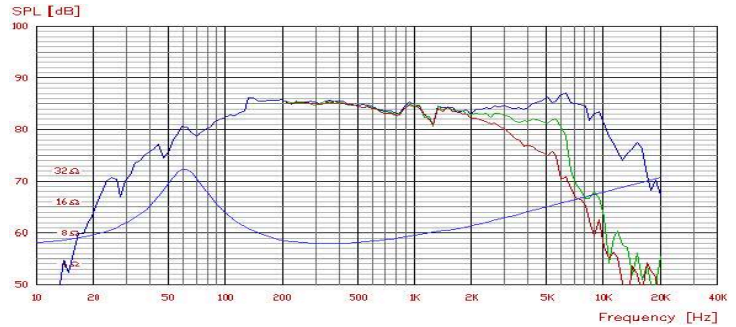
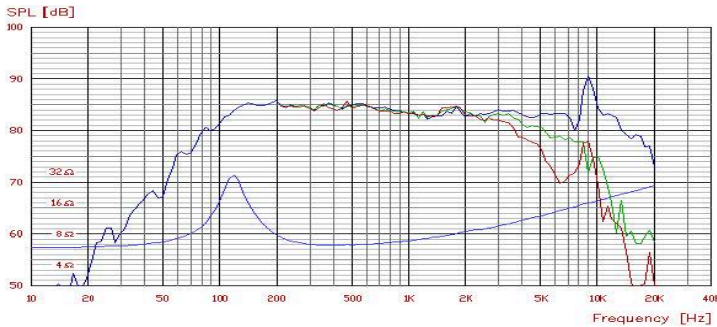

## TC11WG49-08



- 4 1/2" Mid-Woofer
- NRSC coated paper cone
- Rubber surround
- Fibre reinforced polymer chassis
- Vented magnet system
- Flange 125mm
- Cut-out 98.1mm
- Depth 52.8mm

Znom	8 ohm	Sd	58 cm <sup>2</sup>
Re	5.55 ohm	BL	5.2 Tm
Le@1kHz	0.60 mH	Vas	6 ltrs
fs	58 Hz	Xmax	3 mm peak
Qms	2.40	VC Ø	25 mm
Qes	0.44	Sensitivity	
Qts	0.37	2.83V / 1m	85 dB
Mms	5.9 g	Nom. Power DIN	20 W
Cms	- mm/N	Magnet weight	240 g

## TC14SG49-08



- 5 1/2" Shielded Mid-Woofer
- NRSC coated paper cone
- Rubber surround
- Fibre reinforced polymer chassis
- Vented magnet system
- Flange 149mm
- Cut-out 115.5mm
- Depth 68.2mm

Znom	8 ohm	Sd	80 cm <sup>2</sup>
Re	5.55 ohm	BL	5.2 Tm
Le@1kHz	0.60 mH	Vas	10.5 ltrs
fs	53 Hz	Xmax	3 mm peak
Qms	2.73	VC Ø	25 mm
Qes	0.53	Sensitivity	
Qts	0.45	2.83V / 1m	86 dB
Mms	7.8 g	Nom. Power DIN	35 W
Cms	- mm/N	Magnet weight	240 g

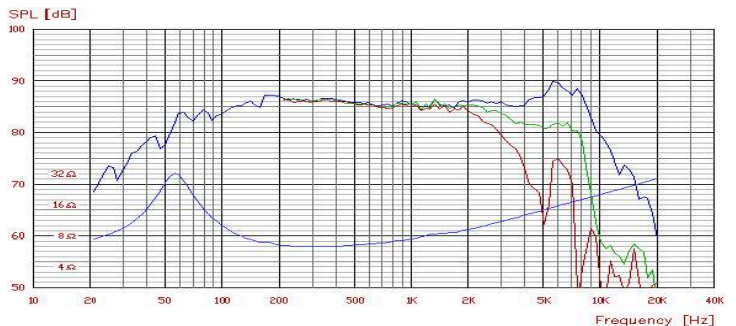
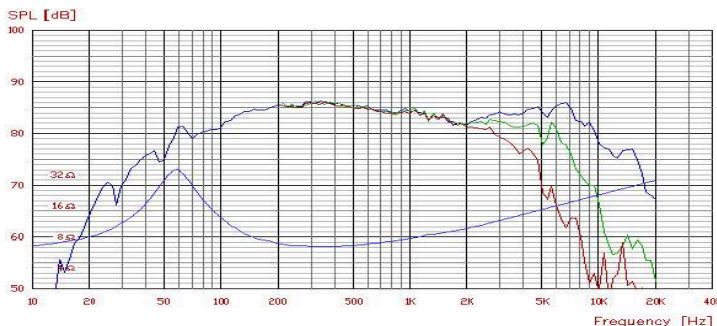



## TC14WG49-08



- 5 1/2" Mid-Woofer
- NRSC coated paper cone
- Rubber surround
- Fibre reinforced polymer chassis
- Vented magnet system
- Flange 149mm
- Cut-out 115.5mm
- Depth 56.7mm

Znom	8 ohm	Sd	80 cm <sup>2</sup>
Re	5.55 ohm	BL	5.2 Tm
Le@1kHz	0.60 mH	Vas	10.5 ltrs
fs	53 Hz	Xmax	3 mm peak
Qms	2.73	VC Ø	25 mm
Qes	0.53	Sensitivity	
Qts	0.45	2.83V / 1m	86 dB
Mms	7.8 g	Nom. Power DIN	35 W
Cms	- mm/N	Magnet weight	240 g

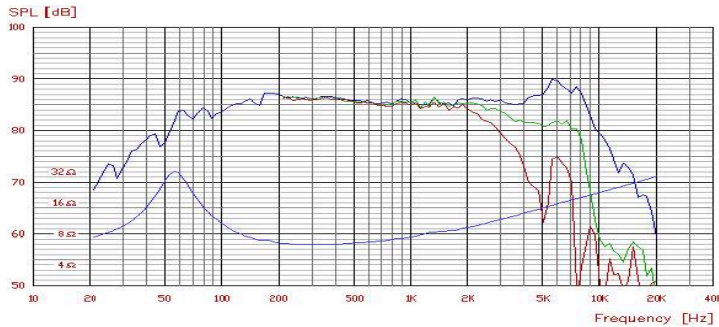

## TC18SG49-08



- 6 1/2" Shielded Woofer
- NRSC coated paper cone
- Rubber surround
- Fibre reinforced polymer chassis
- Vented magnet system
- Flange 180mm
- Cut-out 147mm
- Depth 79.2mm

Znom	8 ohm	Sd	138 cm <sup>2</sup>
Re	5.5 ohm	BL	5.0 Tm
Le@1kHz	0.75 mH	Vas	44 ltrs
fs	37 Hz	Xmax	3 mm peak
Qms	2.62	VC Ø	25 mm
Qes	0.58	Sensitivity	
Qts	0.47	2.83V / 1m	86 dB
Mms	11.2 g	Nom. Power DIN	40 W
Cms	- mm/N	Magnet weight	240 g

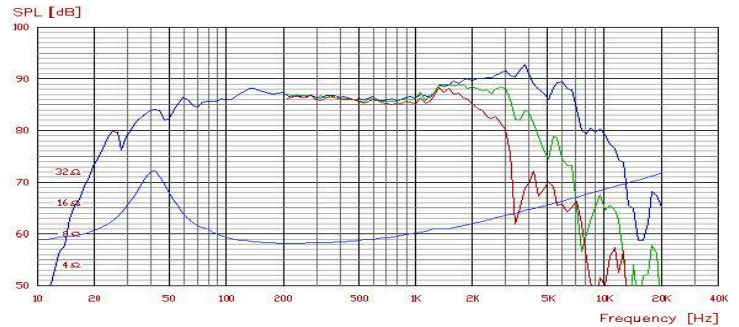

## TC18WG49-08



- 6 1/2" Woofer
- NRSC coated paper cone
- Rubber surround
- Fibre reinforced polymer chassis
- Vented magnet system
- Flange 180mm
- Cut-out 147mm
- Depth 67.9mm

Znom	8 ohm	Sd	138 cm <sup>2</sup>
Re	5.5 ohm	BL	5.0 Tm
Le@1kHz	0.75 mH	Vas	44 ltrs
fs	37 Hz	Xmax	3 mm peak
Qms	2.62	VC Ø	25 mm
Qes	0.58	Sensitivity	
Qts	0.47	2.83V / 1m	86 dB
Mms	11.2 g	Nom. Power DIN	35 W
Cms	- mm/N	Magnet weight	240 g

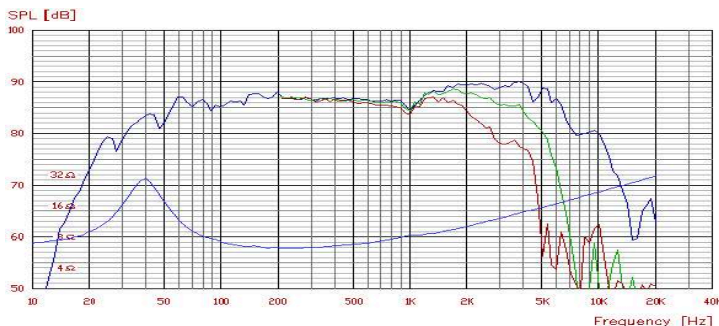

## D19TD-05-08



- 3/4" dome tweeter
- High loss diaphragm
- Magnetic fluid
- High power version
- Good dispersion
- Flange 94mm
- Cut-out 68mm
- Depth 23mm

Znom	8 ohm	Sd	4.2 cm <sup>2</sup>
Re	6.2 ohm	BL	2.6 Tm
Le@1kHz	- mH	Vas	- ltrs
fs	1700 Hz	Xmax	- mm peak
Qms	-	VC Ø	19 mm
Qes	-	Sensitivity	
Qts	-	2.83V / 1m	89 dB
Mms	0.2g	Nom. Power DIN	80 W
Cms	- mm/N	Magnet weight	105 g

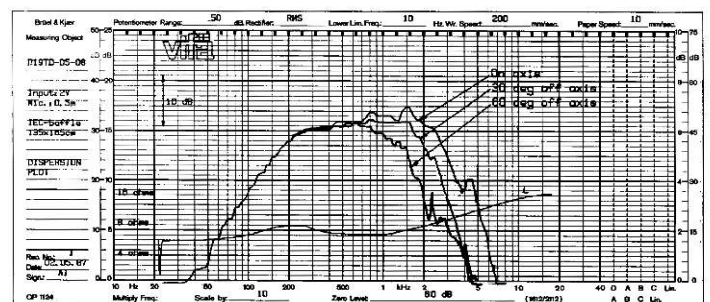



## D20TD-05-06



- 3/4" dome tweeter
- Fabric diaphragm
- Butterfly VC assembly
- Magnetic fluid
- Uncolored sound
- Frequency range to 40kHz
- Flange 94mm
- Cut-out 62mm
- Depth 23.3mm

Znom	6	ohm	Sd	4.4	cm <sup>2</sup>
Re	4.2	ohm	BL	2.2	Tm
Le@1kHz	-	mH	Vas	-	ltrs
fs	1700	Hz	Xmax	-	mm peak
Qms	-		VC Ø	19	mm
Qes	-		Sensitivity		
Qts	-		2.83V / 1m	89	dB
Mms	0.2	g	Nom. Power DIN	100	W
Cms	-	mm/N	Magnet weight	105	kg

## D25ASG-05-06



- 1" dome tweeter
- Shielded magnet
- Aluminum alloy diaphragm
- Magnetic fluid
- Hi loss assembly
- Flange 104mm
- Cutout 79.3mm
- Depth 41.7mm

Znom	6	ohm	Sd	7.1	cm <sup>2</sup>
Re	4.6	ohm	BL	2.95	Tm
Le@1kHz	-	mH	Vas	-	ltrs
fs	1400	Hz	Xmax	-	mm peak
Qms	-		VC Ø	25	mm
Qes	-		Sensitivity		
Qts	-		2.83V / 1m	91	dB
Mms	.3	g	Nom. Power DIN	80	W
Cms	-	mm/N	Magnet weight	432	g

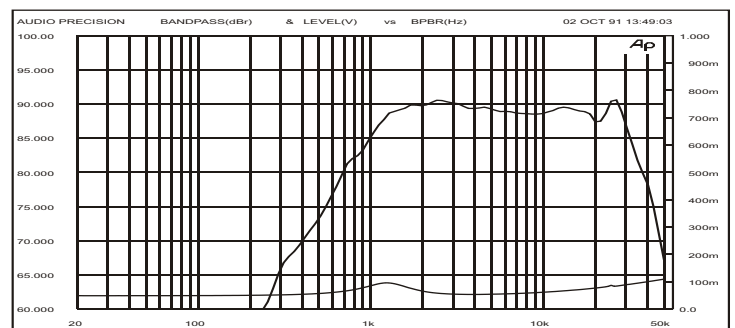
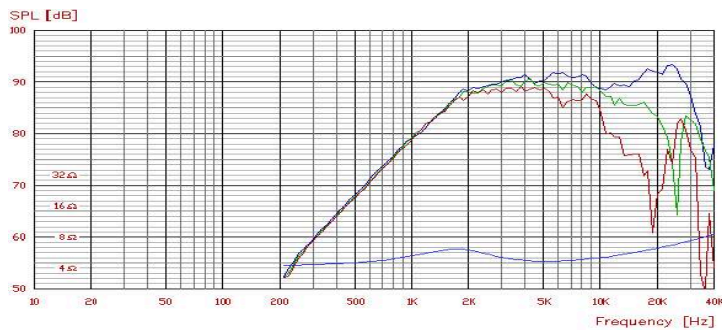

## D25AG-05-06



- 1" dome tweeter
- Aluminum alloy diaphragm
- Magnetic fluid
- High loss assembly
- Piston movement to above 20kHz
- Flange 104mm
- Cut-out 74.3mm
- Depth 28mm

Znom	6	ohm	Sd	7.1	cm <sup>2</sup>
Re	4.6	ohm	BL	3.5	Tm
Le@1kHz	-	mH	Vas	-	ltrs
fs	1500	Hz	Xmax	-	mm peak
Qms	-		VC Ø	25	mm
Qes	-		Sensitivity		
Qts	-		2.83V / 1m	91	dB
Mms	.3	g	Nom. Power DIN	100	W
Cms	-	mm/N	Magnet weight	240	kg

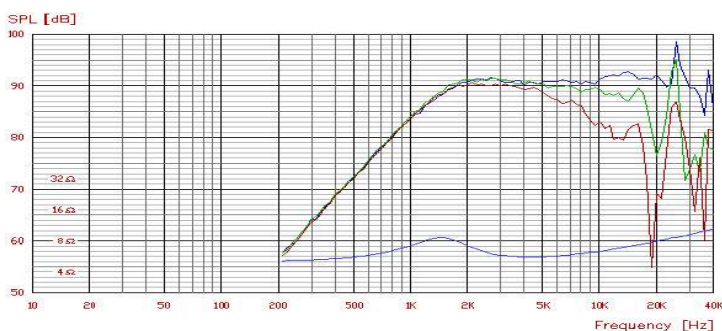

## D25AG-35-06



- 1" dome tweeter
- Aluminum alloy diaphragm
- Magnetic fluid
- Double chamber
- Piston movement to above 20 hz
- Flange 104mm
- Cut-out 74.3mm
- Depth 40mm

Znom	6	ohm	Sd	7.1	cm <sup>2</sup>
Re	4.6	ohm	BL	3.3	Tm
Le@1kHz	-	mH	Vas	-	ltrs
fs	850	Hz	Xmax	-	mm peak
Qms	-		VC Ø	25	mm
Qes	-		Sensitivity		
Qts	-		2.83V / 1m	90	dB
Mms	0.3	g	Nom. Power DIN	100	W
Cms	-	mm/N	Magnet weight	240	g

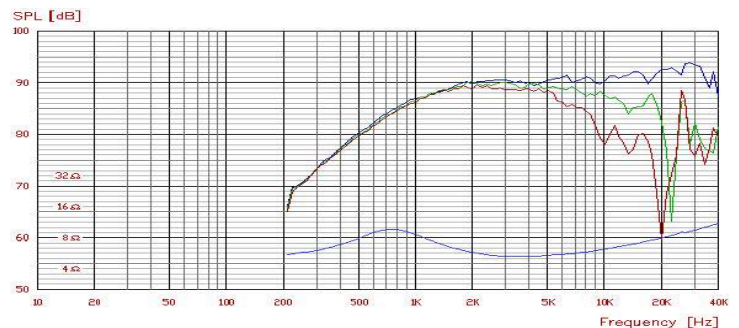

## D27SG-05-06



- 1" dome tweeter
- Shielded magnet
- Coated fabric with silk diaphragm
- Double magnet
- Linear response front plate, neutral design
- Flange 104mm
- Cut-out 79.3mm
- Depth 41.7mm

Znom	6	ohm	Sd	7.1	cm <sup>2</sup>
Re	4.6	ohm	BL	2.7	Tm
Le@1kHz	-	mH	Vas	-	ltrs
fs	1000	Hz	Xmax	-	mm peak
Qms	-		VC Ø	26	mm
Qes	-		Sensitivity		
Qts	-		2.83V / 1m	92	dB
Mms	.3	g	Nom. Power DIN	80	W
Cms	-	mm/N	Magnet weight	432	kg

## D27TG-05-06



- 1" dome tweeter
- Coated fabric with silk diaphragm
- Linear response front plate, neutral design
- Magnetic fluid
- Flange 104mm
- Cut-out 73.5mm
- Depth 31.5mm

Znom	6	ohm	Sd	7.1	cm <sup>2</sup>
Re	4.6	ohm	BL	2.7	Tm
Le@1kHz	-	mH	Vas	-	ltrs
fs	1000	Hz	Xmax	-	mm peak
Qms	2.15		VC Ø	26	mm
Qes	1.19		Sensitivity		
Qts	0.77		2.83V / 1m	92	dB
Mms	0.3	g	Nom. Power DIN	100	W
Cms	-	mm/N	Magnet weight	240	g

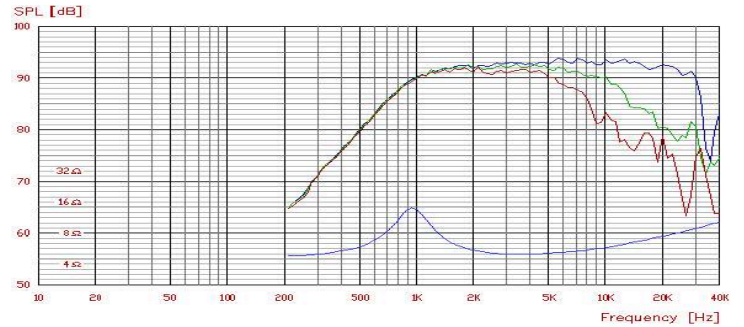
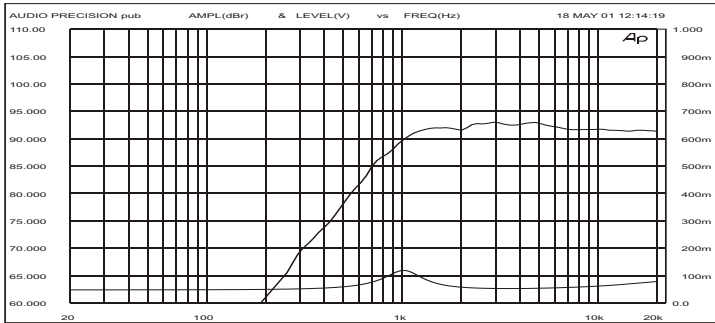

## D27TG-35-06



- 1" dome tweeter
- Coated fabric with silk diaphragm
- Linear response frontplate, neutral design
- Magnetic fluid
- Braids and rear chamber
- Flange 104mm
- Cut-out 73.5mm
- Depth 55mm

Znom	6	ohm	Sd	7.1	cm <sup>2</sup>
Re	4.6	ohm	BL	2.7	Tm
Le@1kHz	-	mH	Vas	-	ltrs
fs	650	Hz	Xmax	-	mm peak
Qms	0.95		VC Ø	26	mm
Qes	0.77		Sensitivity		
Qts	0.43		2.83V / 1m	91	dB
Mms	.3	g	Nom. Power DIN	100	W
Cms	-	mm/N	Magnet weight	240	g

## D27TG-45-06



- 1" dome tweeter
- Coated fabric with silk diaphragm
- Linear response frontplate
- Magnetic fluid
- Braids and rear chamber
- Diameter 104mm
- Cut-out 73.5mm
- Depth 55mm

Znom	6	ohm	Sd	7.1	cm <sup>2</sup>
Re	4.6	ohm	BL	-	Tm
Le@1kHz	-	mH	Vas	-	ltrs
fs	650	Hz	Xmax	-	mm peak
Qms	0.95		VC Ø	26	mm
Qes	0.77		Sensitivity		
Qts	0.43		2.83V / 1m	91	dB
Mms	.3	g	Nom. Power DIN	100	W
Cms	-	mm/N	Magnet weight	240	g

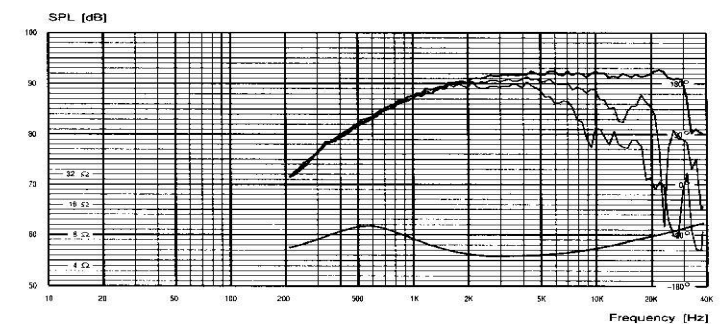
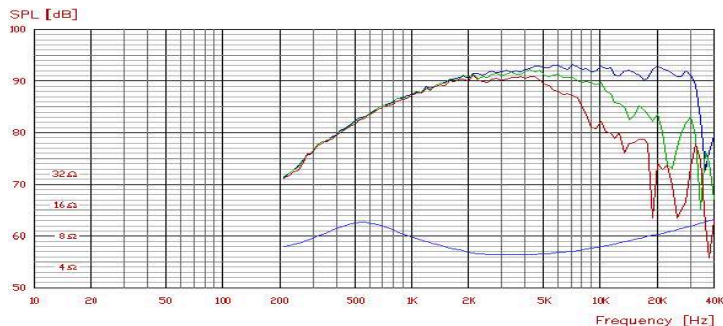



## H26TG-35-06



- 1" imp.transformer
- Chambered
- Fabric diaphragm
- Butterfly VC assembly
- Improved air load on diaphragm
- Magnetic fluid
- Flange 104mm
- Cut-out 73.5mm
- Depth 57.5mm

Znom	6 ohm	Sd	7.1 cm <sup>2</sup>
Re	4.6 ohm	BL	3.3 Tm
Le@1kHz	- mH	Vas	- ltrs
fs	940 Hz	Xmax	- mm peak
Qms	-	VC Ø	25 mm
Qes	-	Sensitivity	
Qts	-	2.83V / 1m	96 dB
Mms	.33 g	Nom. Power DIN	100 W
Cms	- mm/N	Magnet weight	240 g

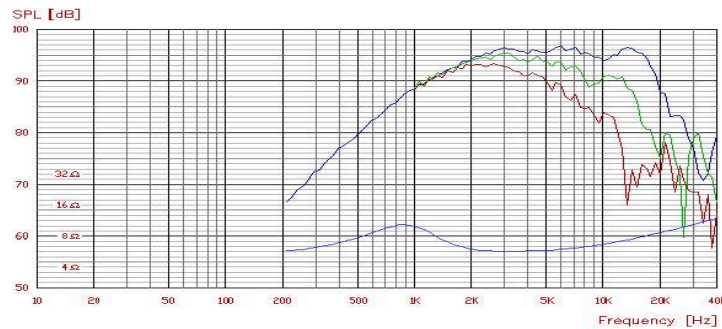

## D26NC-55-06



- 1" textile dome tweeter
- Neodymium magnet
- Heat sink for increased power handling and lower distortion
- Ferrofluid cooled
- Truncated face plate
- Flange 70mm (54Trun.)
- Cut-out 49.2mm
- Depth 23mm

Znom	6 ohm	Sd	7.1 cm <sup>2</sup>
Re	4.6 ohm	BL	2.5 Tm
Le@1kHz	0.05 mH	Vas	- ltrs
fs	1500 Hz	Xmax	0.25 mm peak
Qms	1.48	VC Ø	25 mm
Qes	2.29	Sensitivity	
Qts	0.90	2.83V / 1m	91 dB
Mms	0.33 g	Nom. Power DIN	50 W
Cms	- mm/N	Magnet weight	0.01 kg

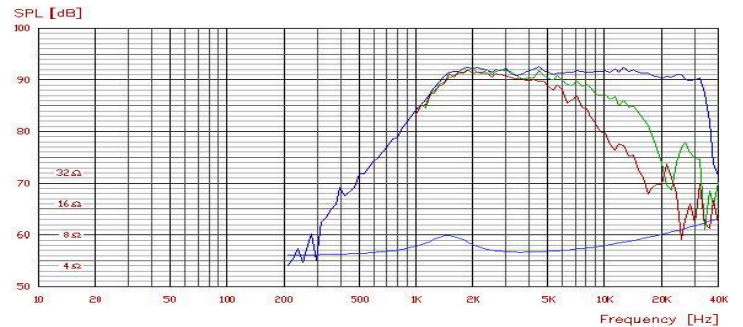

## M10MD39-08



- 4" midrange
- Magnesium basket
- Rubber surround- low resonance
- Double magnet
- Very smooth midrange
- Neutral reproduction
- Flange 104mm
- Cut-out 81.2mm
- Depth 49mm

Znom	8 ohm	Sd	62 cm <sup>2</sup>
Re	5.4 ohm	BL	4.0 Tm
Le@1kHz	0.12 mH	Vas	1.3 ltrs
fs	110 Hz	Xmax	0.65 mm peak
Qms	1.33	VC Ø	25 mm
Qes	0.61	Sensitivity	
Qts	0.42	2.83V / 1m	88 dB
Mms	5.0 g	Nom. Power DIN	80 W
Cms	0.68 mm/N	Magnet weight	210 g

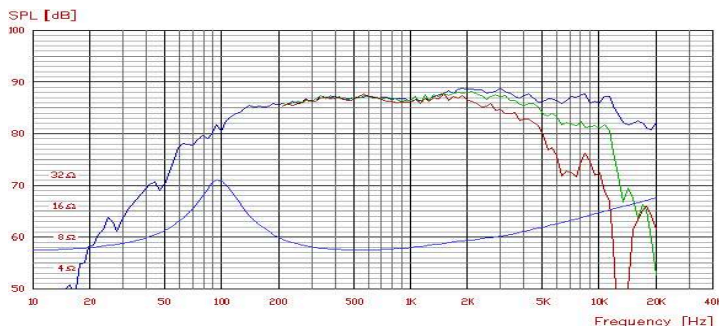

## P13MH-00-08



- 5" midrange
- Mineral filled polycone
- Low resonance
- Very low distortion
- Optimized off axis response
- Vented pole piece
- Flange 140mm
- Cut-out 112mm
- Depth 64.5mm

Znom	8 ohm	Sd	86 cm <sup>2</sup>
Re	5.8 ohm	BL	5.8 Tm
Le@1kHz	- mH	Vas	10 ltrs
fs	60 Hz	Xmax	1 mm peak
Qms	1.46	VC Ø	25 mm
Qes	.42	Sensitivity	
Qts	.33	2.83V / 1m	89.5 dB
Mms	6.5 g	Nom. Power DIN	100 W
Cms	- mm/N	Magnet weight	0.04 kg

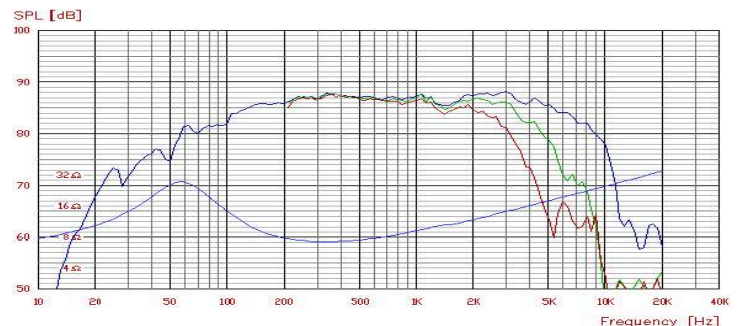



## C11WG-09-04



- 4.5" coated paper cone woofer
- Rubber surround
- Vented pole piece
- Stamped frame
- Flat response to 6kHz
- Vented VC former
- Flange 106.6mm sq
- Cut-out 92mm Ø
- Depth 54mm

Znom	4 ohm	Sd	55.0 cm <sup>2</sup>
Re	3.2 ohm	BL	3.8 Tm
Le@1kHz	0.4 mH	Vas	4.2 ltrs
fs	72 Hz	Xmax	2.00 mm peak
Qms	2.2	VC Ø	25 mm
Qes	0.49	Sensitivity	
Qts	0.40	2.83V / 1m	88 dB
Mms	4.9 g	Nom. Power DIN	30 W
Cms	- mm/N	Magnet weight	0.24 kg

## M13SG-09-08



- 5" woofer
- Magnetically shielded
- Very smooth frequency response
- High damping rubber surround
- Good for bass reflex
- Flange 140mm
- Cut-out 112.3mm
- Depth 73.6mm

Znom	8 ohm	Sd	80 cm <sup>2</sup>
Re	5.6 ohm	BL	5.2 Tm
Le@1kHz	- mH	Vas	12 ltrs
fs	54 Hz	Xmax	2 mm peak
Qms	1.50	VC Ø	25 mm
Qes	0.46	Sensitivity	
Qts	0.35	2.83V / 1m	88 dB
Mms	6.5 g	Nom. Power DIN	35 W
Cms	- mm/N	Magnet weight	344 g

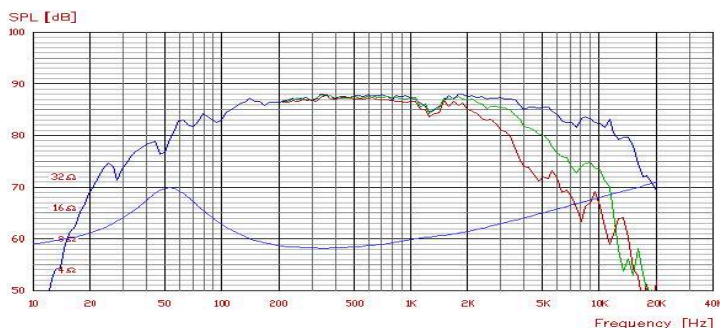
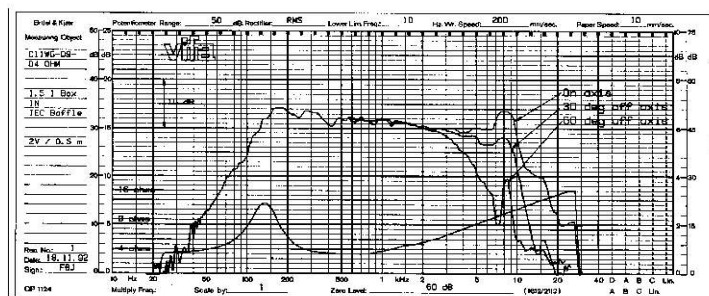

## P13WH-00-08



- 5" Mineral filled polycone
- Rubber surround
- Magnesium basket
- Smooth roll off
- Neutral midrange
- Vented pole piece
- Flange 140mm
- Cut-out 112.3mm
- Depth 64.5mm

Znom	8 ohm	Sd	86 cm <sup>2</sup>
Re	5.7 ohm	BL	6.0 Tm
Le@1kHz	.7 mH	Vas	10 ltrs
fs	60 Hz	Xmax	4 mm peak
Qms	1.38	VC Ø	25 mm
Qes	0.43	Sensitivity	
Qts	0.33	2.83V / 1m	88 dB
Mms	7.5 g	Nom. Power DIN	40 W
Cms	- mm/N	Magnet weight	415 g

## M17SG-09-08



- 6-1/2" woofer
- Magnetically shielded
- Smooth response
- Rubber surround
- Good for bass reflex
- Vented through shielding cup
- Flange 170mm
- Cut-out 145.5mm
- Depth 85mm

Znom	8 ohm	Sd	137 cm <sup>2</sup>
Re	5.6 ohm	BL	5.3 Tm
Le@1kHz	.7 mH	Vas	53 ltrs
fs	34 Hz	Xmax	3 mm peak
Qms	1.36	VC Ø	25 mm
Qes	0.47	Sensitivity	
Qts	0.34	2.83V / 1m	89 dB
Mms	11 g	Nom. Power DIN	50 W
Cms	- mm/N	Magnet weight	344 g

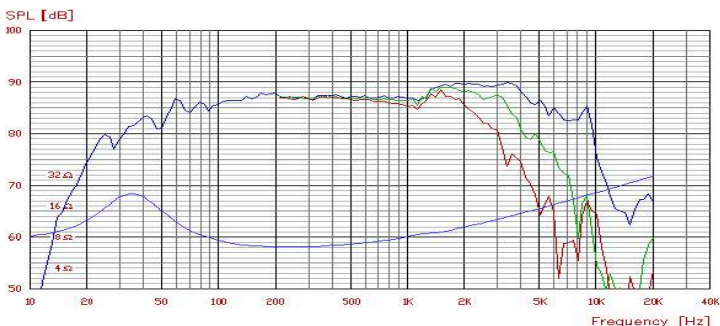
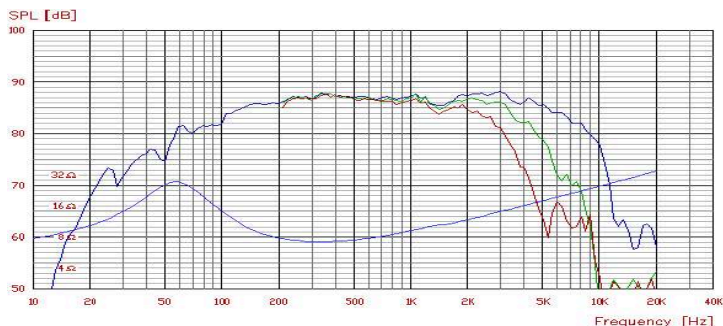

## P17SJ-00-08



- 6-1/2" woofer
- Magnesium basket
- Mineral filled polycone
- Rubber surround
- Smooth response
- Magnetically shielded
- Flange 170mm
- Cut-out 145.8mm
- Depth 93.1mm

Znom	8 ohm	Sd	136 cm <sup>2</sup>
Re	5.6 ohm	BL	6 Tm
Le@1kHz	.84 mH	Vas	33 ltrs
fs	41 Hz	Xmax	4.5 mm peak
Qms	1.28	VC Ø	32 mm
Qes	0.48	Sensitivity	
Qts	0.35	2.83V / 1m	87/87 dB
Mms	12 g	Nom. Power DIN	20 W
Cms	- mm/N	Magnet weight	721 g

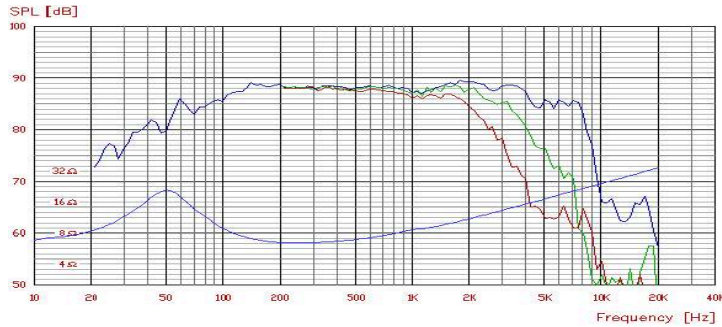

## P17WJ-00-08



- 6-1/2" woofer
- Magnesium basket
- Mineral filled polycone
- Rubber surround
- Smooth response
- Ideal for bass reflex
- Flange 170mm
- Cut-out 145.5mm
- Depth 75.1mm

Znom	8 ohm	Sd	136 cm <sup>2</sup>
Re	5.8 ohm	BL	6.5 Tm
Le@1kHz	.55 mH	Vas	34.7 ltrs
fs	37 Hz	Xmax	4.5 mm peak
Qms	1.55	VC Ø	32 mm
Qes	0.45	Sensitivity	
Qts	0.35	2.83V / 1m	88 dB
Mms	14 g	Nom. Power DIN	70 W
Cms	- mm/N	Magnet weight	415 g

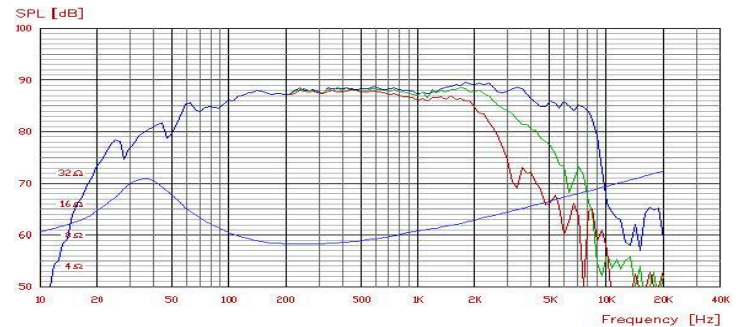

## M18WO-09-08



- 7" woofer
- Long stroke
- Magnesium basket
- Rubber surround
- Kapton former
- 24.6 oz. Magnet
- Ideal for bass reflex
- Flange 180mm
- Cut-out 145mm
- Depth 85mm

Znom	8 ohm	Sd	132 cm <sup>2</sup>
Re	5.7 ohm	BL	7.5 Tm
Le@1kHz	0.90 mH	Vas	28.5 ltrs
fs	35 Hz	Xmax	4 mm peak
Qms	6.70	VC Ø	40 mm
Qes	0.39	Sensitivity	
Qts	0.37	2.83V / 1m	87.5 dB
Mms	17.5 g	Nom. Power DIN	70 W
Cms	- mm/N	Magnet weight	698 g

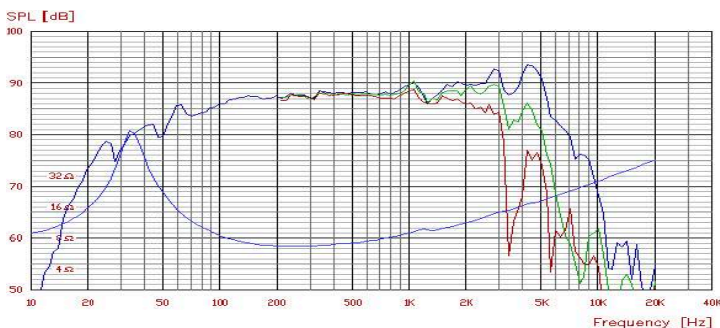

## M21WO-39-08



- 8" woofer
- Coated paper cone
- Rubber surround
- Long throw
- Low distortion
- Flat response
- Ideal for bass reflex
- Flange 215.2mm
- Cut-out 186.5mm
- Depth 86mm

Znom	8 ohm	Sd	235 cm <sup>2</sup>
Re	5.5 ohm	BL	8.2 Tm
Le@1kHz	1.0 mH	Vas	105 ltrs
fs	28 Hz	Xmax	6 mm peak
Qms	1.97	VC Ø	40 mm
Qes	0.35	Sensitivity	
Qts	0.30	2.83V / 1m	90 dB
Mms	23 g	Nom. Power DIN	80 W
Cms	- mm/N	Magnet weight	698 g

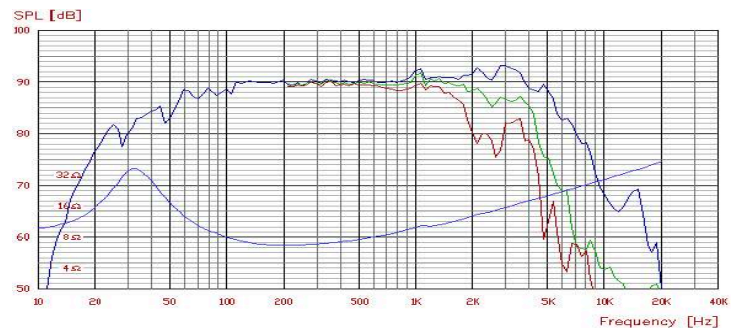



## P21WO-20-08



- 8" woofer
- Magnesium basket
- Mineral filled poly cone
- Rubber surround
- Flat response
- Ideal for bass reflex
- Flange 215mm
- Cut-out 186.5mm
- Depth 80.4

Znom	8 ohm	Sd	235 cm <sup>2</sup>
Re	5.7 ohm	BL	7.4 Tm
Le@1kHz	0.9 mH	Vas	113 ltrs
fs	28 Hz	Xmax	4 mm peak
Qms	1.6	VC Ø	40 mm
Qes	0.41	Sensitivity	
Qts	0.33	2.83V / 1m	91 dB
Mms	22.5 g	Nom. Power DIN	80 W
Cms	- mm/N	Magnet weight	698 g

## P21WO-39-08



- 8" Polypropylene cone woofer
- Rubber surround
- Cast magnesium frame
- Long throw / low distortion motor
- Good for vented boxes
- Flange 215.2mm
- Cut-out 186.5mm
- Depth 82.1mm

Znom	8 ohm	Sd	235.0 cm <sup>2</sup>
Re	5.5 ohm	BL	8.5 Tm
Le@1kHz	1.0 mH	Vas	85 ltrs
fs	26 Hz	Xmax	6.0 mm peak
Qms	2.38	VC Ø	40 mm
Qes	0.44	Sensitivity	
Qts	0.37	2.83V / 1m	88 dB
Mms	32.0 g	Nom. Power DIN	80 W
Cms	- mm/N	Magnet weight	0.7 kg

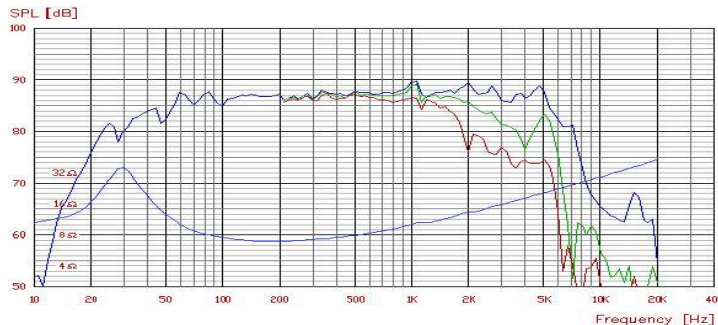
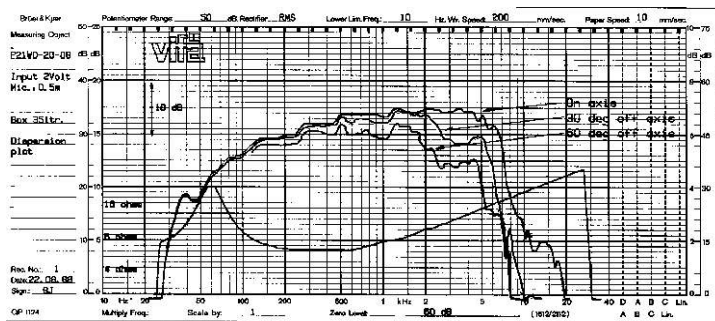

## M26WR-09-08



- 10" woofer
- Long stroke
- Magnesium basket
- Rubber surround
- Rigid conical paper cone
- 2" voice coil
- Ideal for bass reflex
- Flange 271mm
- Cut-out 231.2mm
- Depth 106.7mm

Znom	8 ohm	Sd	337 cm <sup>2</sup>
Re	5.8 ohm	BL	11 Tm
Le@1kHz	1.8 mH	Vas	130 ltrs
fs	26 Hz	Xmax	6.5 mm peak
Qms	2.82	VC Ø	50 mm
Qes	0.36	Sensitivity	
Qts	0.32	2.83V / 1m	88.5 dB
Mms	45 g	Nom. Power DIN	130 W
Cms	- mm/N	Magnet weight	1062 g

## MA26WR-09-04



- 10" Black Aluminum cone woofer
- Rubber surround
- Magnesium cast frame
- Double magnet
- F3 of 33Hz in 1.5 cubic foot sealed box!
- Flange 271mm
- Cut-out 231.2mm
- Depth 124mm

Znom	4 ohm	Sd	333.0 cm <sup>2</sup>
Re	3.44 ohm	BL	11.3 Tm
Le@1kHz	1.2 mH	Vas	60.6 ltrs
fs	21 Hz	Xmax	11.6 mm peak
Qms	3.53	VC Ø	50 mm
Qes	0.52	Sensitivity	
Qts	0.46	2.83V / 1m	83.3 dB
Mms	149.3 g	Nom. Power DIN	300 W
Cms	384.8 µm/N	Magnet weight	2.1 kg

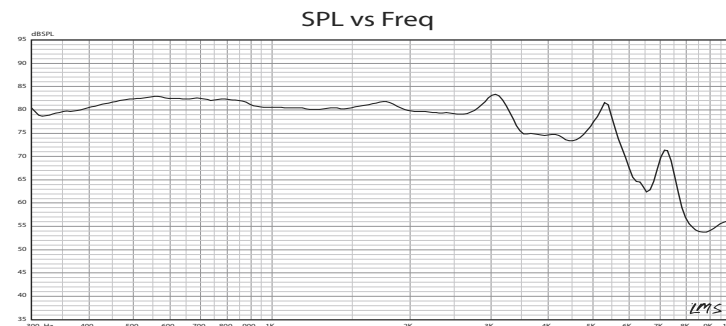
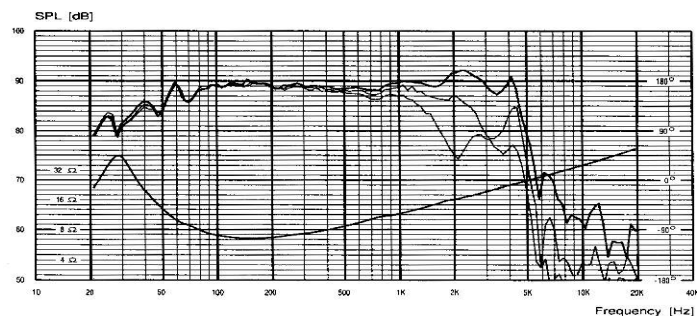



## D25AC-05-06



- 1" aluminum dome autosound tweeter
- Metal grill
- Compact construction
- Butterfly VC assembly
- Magnetic fluid
- Neodymium magnet
- Flange 45mm
- Cut-out 45mm
- Depth 22mm

Znom	6 ohm	Sd	7.1 cm <sup>2</sup>
Re	4.6 ohm	BL	2.5 Tm
Le@1kHz	- mH	Vas	- ltrs
fs	1700 Hz	Xmax	0.2 mm peak
Qms	-	VC Ø	25 mm
Qes	-	Sensitivity	
Qts	-	2.83V / 1m	90.5 dB
Mms	0.3 g	Nom. Power DIN	30 W
Cms	- mm/N	Magnet weight	0.01 kg

## D26NC-05-06



- 1" textile dome autosound tweeter
- Compact construction
- Butterfly VC assembly
- Magnetic fluid
- Metal grill
- Neodymium magnet
- Flange 45mm
- Cut-out 45mm
- Depth 22mm

Znom	6 ohm	Sd	7.1 cm <sup>2</sup>
Re	4.6 ohm	BL	2.5 Tm
Le@1kHz	- mH	Vas	- ltrs
fs	1800 Hz	Xmax	- mm peak
Qms	-	VC Ø	25 mm
Qes	-	Sensitivity	
Qts	-	2.83V / 1m	91.5 dB
Mms	.27 g	Nom. Power DIN	30 W
Cms	- mm/N	Magnet weight	11 g

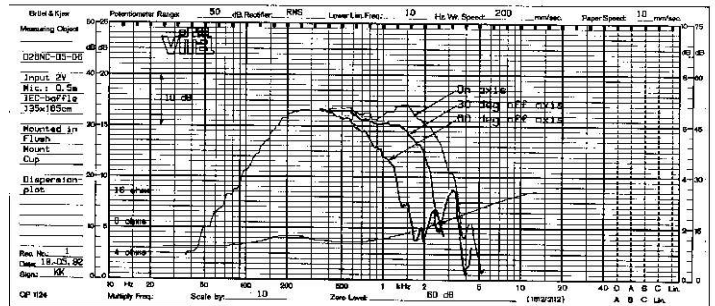
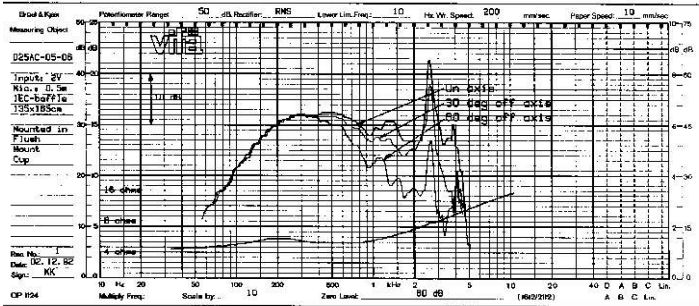

## P13WH-10-04



- 5" autosound woofer
- Mineral filled polycone
- Rubber surround
- Smooth roll off
- Optimized off-axis response
- Neutral midrange
- Flange 140mm
- Cut-out 114.5mm
- Depth 64.5mm

Znom	4 ohm	Sd	87 cm <sup>2</sup>
Re	3.0 ohm	BL	5 Tm
Le@1kHz	0.4 mH	Vas	5 ltrs
fs	80 Hz	Xmax	3 mm peak
Qms	2.35	VC Ø	25 mm
Qes	0.49	Sensitivity	
Qts	0.41	2.83V / 1m	87.5 dB
Mms	8 g	Nom. Power DIN	40 W
Cms	- mm/N	Magnet weight	415 g

## M18WN-19-04



- 6-1/2" autosound woofer
- Long stroke
- Magnesium basket
- Rubber surround
- Moisture resistant rigid paper cone
- Kapton former
- Flange 180mm
- Cut-out 145mm
- Depth 83mm

Znom	4 ohm	Sd	132 cm <sup>2</sup>
Re	3.0 ohm	BL	4.8 Tm
Le@1kHz	0.6 mH	Vas	10 ltrs
fs	63 Hz	Xmax	4 mm peak
Qms	3.88	VC Ø	40 mm
Qes	0.80	Sensitivity	
Qts	0.66	2.83V / 1m	85 dB
Mms	15.5 g	Nom. Power DIN	110 W
Cms	- mm/N	Magnet weight	415 g

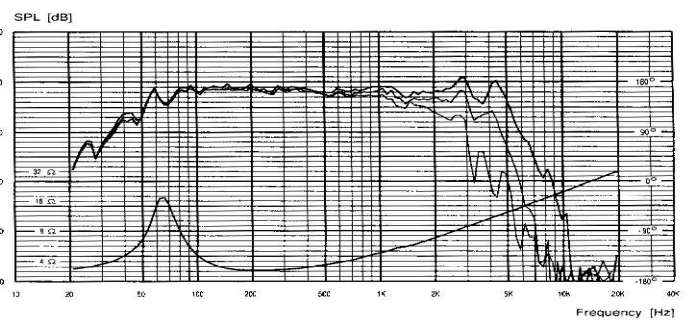
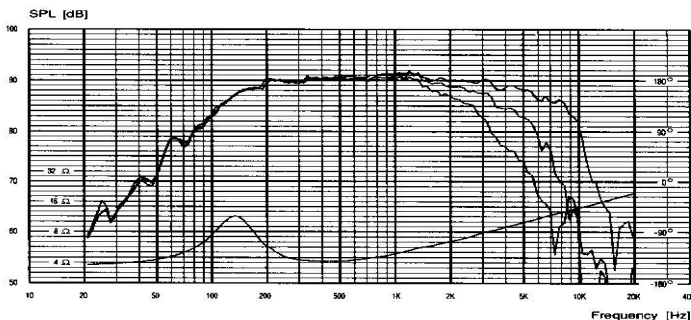

### A10WG-09-04



- 4" autosound woofer
- NRSC coated paper cone
- Rubber surround
- Fiber reinforced polymer chassis with removable corners
- Vented VC former and magnet system
- Humidity & Heat resistant

Znom	4 ohm	Sd	44 cm <sup>2</sup>
Re	3.1 ohm	BL	4.4 Tm
Le@1kHz	0.4 mH	Vas	0.8 ltrs
fs	125 Hz	Xmax	3 mm peak
Qms	2.68	VC Ø	25 mm
Qes	0.69	Sensitivity	
Qts	0.55	2.83V / 1m	87 dB
Mms	5.5 g	Nom. Power DIN	30 W
Cms	0.29 mm/N	Magnet weight	240 g

### A13WG-09-04



- 5" autosound woofer
- NRSC coated paper cone
- Rubber surround
- Fiber reinforced polymer chassis with removable corners
- Vented VC former and magnet system
- Humidity & Heat resistant

Znom	4 ohm	Sd	80 cm <sup>2</sup>
Re	3.12 ohm	BL	4.3 Tm
Le@1kHz	0.5 mH	Vas	4.8 ltrs
fs	80 Hz	Xmax	3 mm peak
Qms	3.78	VC Ø	25 mm
Qes	0.62	Sensitivity	
Qts	0.53	2.83V / 1m	89 dB
Mms	5.5 g	Nom. Power DIN	40 W
Cms	0.53 mm/N	Magnet weight	240 g

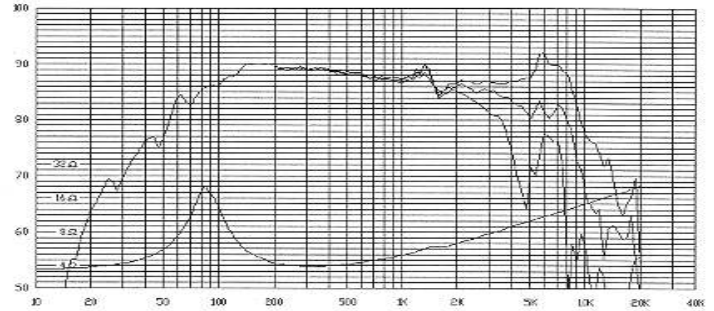
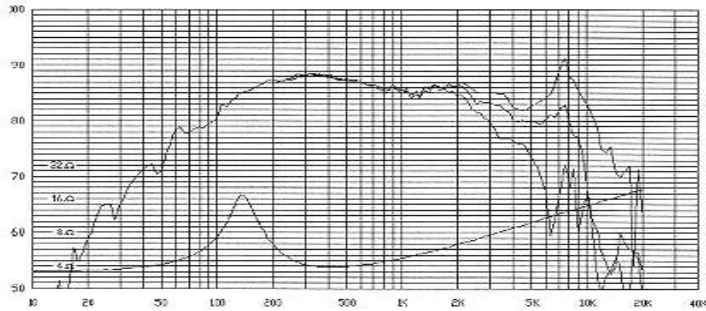

### A16WG-09-04



- 6.5" autosound woofer
- NRSC coated paper cone
- Rubber surround
- Fiber reinforced polymer chassis with removable corners
- Vented VC former and magnet system
- Humidity & Heat resistant

Znom	4 ohm	Sd	138 cm <sup>2</sup>
Re	3.1 ohm	BL	4.3 Tm
Le@1kHz	0.5 mH	Vas	19.6 ltrs
fs	57 Hz	Xmax	3 mm peak
Qms	3.22	VC Ø	25 mm
Qes	0.64	Sensitivity	
Qts	0.54	2.83V / 1m	90 dB
Mms	10.7 g	Nom. Power DIN	60 W
Cms	0.73 mm/N	Magnet weight	240 g

### A10CG-09-04/06



- 4" Coaxial autosound speaker
- 20mm textile dome tweeter with neodymium magnet
- NRSC coated paper cone
- Rubber surround
- Fiber reinforced polymer chassis
- **Crossover \$18.00 each**

Znom	4/6 ohm	Sd	44/4.4 cm <sup>2</sup>
Re	3.1/4.2 ohm	BL	4.4 Tm
Le@1kHz	0.4 mH	Vas	0.8 ltrs
fs	125/1800 Hz	Xmax	3 mm peak
Qms	2.68	VC Ø	25/20 mm
Qes	0.69	Sensitivity	
Qts	0.55	2.83V / 1m	87/86.5 dB
Mms	5.5/0.2 g	Nom. Power	30/20 W
Cms	0.29 mm/N	Magnet weight	240 g

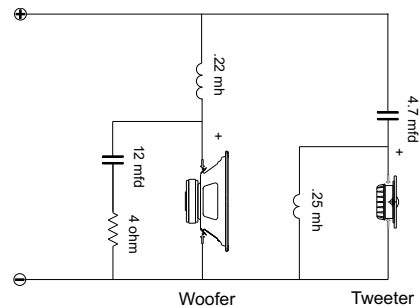
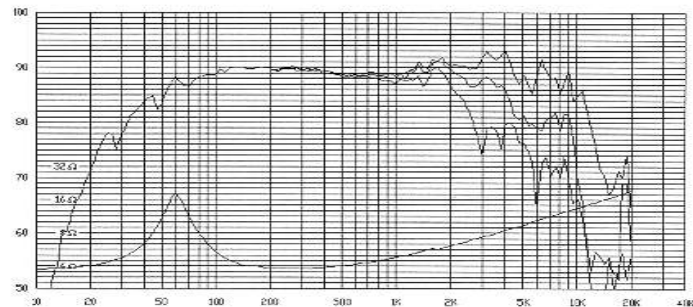



## A13CG-09-04



- 5" Coaxial autosound speaker
- 20mm textile dome tweeter with neodymium magnet
- NRSC coated paper cone
- Rubber surround
- Fiber reinforced polymer chassis
- **Crossover \$18.00 each**

## A16CG-09-04



- 6.5" Coaxial autosound speaker
- 20mm textile dome tweeter with neodymium magnet
- NRSC coated paper cone
- Rubber surround
- Fiber reinforced polymer chassis
- **Crossover \$20.50 each**

Znom	4/6	ohm	Sd	80/4.4	cm <sup>2</sup>
Re	3.1/4.2	ohm	BL	4.3	Tm
Le@1kHz	0.5	mH	Vas	4.8	ltrs
fs	80/1800	Hz	Xmax	3	mm peak
Qms	3.78		VC Ø	25/20	mm
Qes	0.62		Sensitivity		
Qts	0.53		2.83V / 1m	89/86.5	dB
Mms	5.5/0.2	g	Nom. Power	40/20	W
Cms	0.53	mm/N	Magnet weight	240	g

Znom	4/6	ohm	Sd	138/4.4	cm <sup>2</sup>
Re	3.1/4.2	ohm	BL	4.3	Tm
Le@1kHz	0.5	mH	Vas	19.6	ltrs
fs	57/1800	Hz	Xmax	3	mm peak
Qms	3.22		VC Ø	25/20	mm
Qes	0.64		Sensitivity		
Qts	0.54		2.83V / 1m	90/86.5	dB
Mms	10.7/0.2	g	Nom. Power	60/20	W
Cms	0.73	mm/N	Magnet weight	240	g

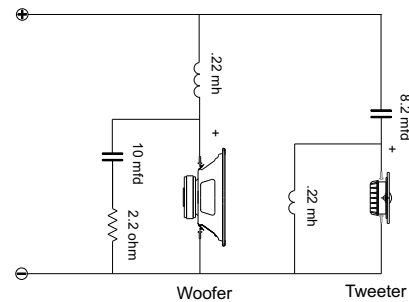
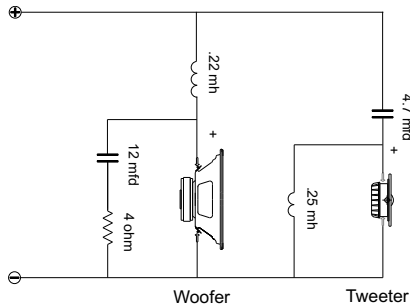

V  
I  
F  
A  
  
S  
O  
L  
O



V  
I  
F  
A  
  
S  
U  
R  
R  
O  
U  
N  
D



V  
I  
F  
A  
  
A  
/  
V

<i>Replacement Tweeter Voice Coils</i>		
600010	D26TG05	\$9.50
600011	D20TD05	\$10.45
600013	D26TG35	\$10.65
600021	Hales D26AG38-04 (D26X-008)	\$36.00
600028	D25AG05, D25SG05	\$13.55
600029	D25AG35	\$16.20
600031	D19AD05	\$13.55
600045	D26NC05, NC15, NC55	\$11.65
600055	D25AC05	\$13.55
600057	D27TG05, D27TG15	\$9.80
600058	D27TG35, D27TG45	\$11.05
690002	D19TD05, D19SD05	\$8.75
600130	MG27SG29, MG27TG29, MG27TG39	\$12.80



# Home Theater Speakers from Madisound & Vifa

If you have been looking for Home Theater speakers that are better than the current choices on the market, Madisound and Vifa have some good news for you. Vifa has designed exceptional shielded high fidelity loudspeakers for this purpose, and Madisound has matched these drivers with precise crossovers and beautiful oak veneer cabinets.

The following designs were developed using Madisound's anechoic chamber, Audio Precision measurement and Leap analysis. All three speakers use the Vifa M13SG09, a 13cm paper cone, cast frame woofer. The tweeter is the D25ASG05, which is also shielded and has a 25mm aluminum dome. The cabinets are oak veneered 19mm fiber board, with solid rounded oak corners and a black assembled grill. You may choose between black stained or clear oak finishes. Everything you need to complete the system is included. The crossovers are assembled and the cabinets are pre-cut for easy assembly. You can expect to assemble a pair of speaker in one evening. As with all Madisound kits, your satisfaction is guaranteed

## Vifa Solo Shielded 2-way Audio/Video Speaker Price Each \$185.00

H - 12"  
W - 8"  
D - 10 1/4"

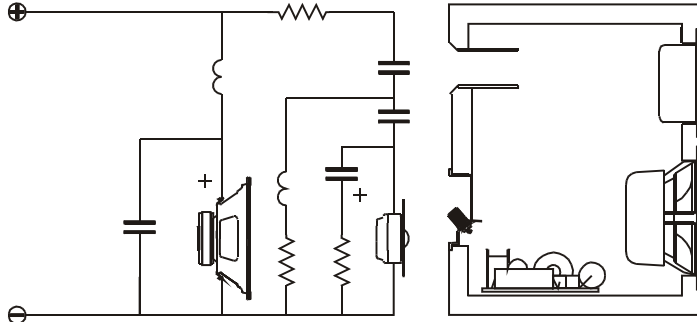
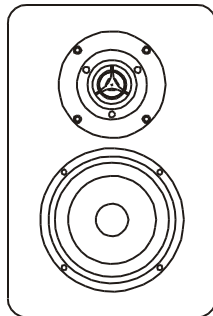

Price w/o  
cabinets  
\$110.00

Nominal Impedance: 8 ohms

Frequency range  $\pm 3\text{dB}$ : 60Hz to 35KHz - Vented

## Vifa A/V Shielded MTM Audio/Video Speaker Price Each \$228.00

H - 18 1/2"  
W - 8"  
D - 10 1/2"

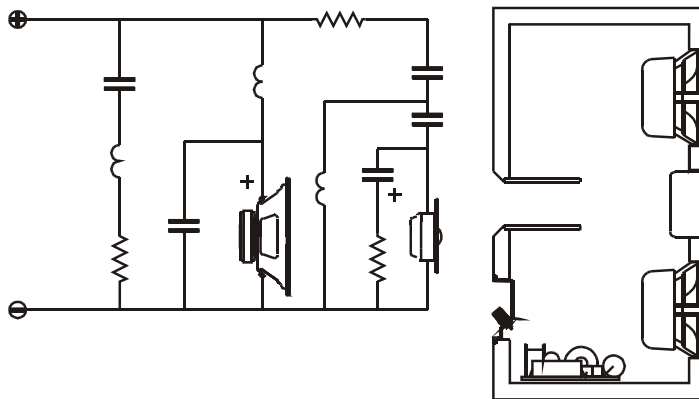
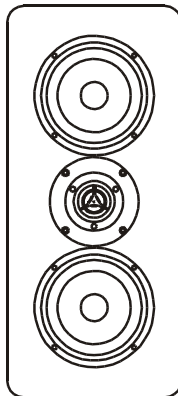

Price w/o  
cabinets  
\$145.00

Nominal Impedance: 8 ohms

Frequency range  $\pm 3\text{dB}$ : 55Hz to 35KHz - Vented

## Vifa Surround Dipole/Bipole A/V Speaker Price Each \$290.00

H - 14"  
W - 8"  
D - 12"

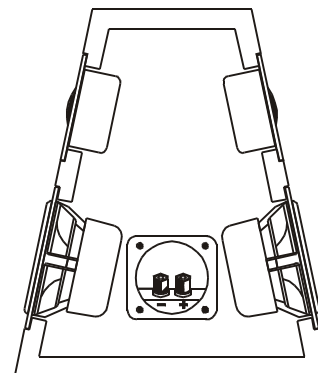
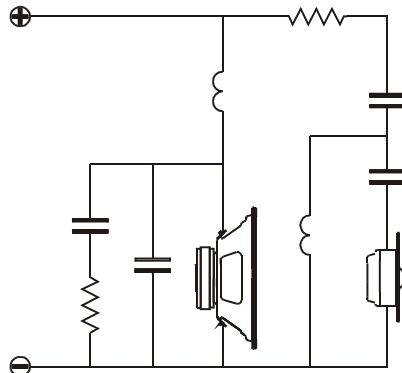
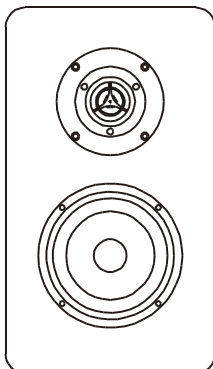

Price w/o  
cabinets  
\$180.00

Nominal Impedance: 8 ohms

Frequency range  $\pm 3\text{dB}$ : 80Hz to 35KHz - Sealed

These kits are also available with the Vifa **D27SG05** silk dome tweeter for slightly less \$.



# EMINENCE PROFESSIONAL LOUDSPEAKERS

Complete specifications available at: [www.eminence.com](http://www.eminence.com)



Model	Imp. W	Fs Hz	Qts	Vas Ltrs	Power Watts	dB	Frequency Range	VC Ø Inches	Rec. Box Size ft <sup>3</sup> S / V	Magnet Weight oz	Price Each
<b>APT High Power Super-Tweeters</b>											
APT50 driver only, no horn	8	250	-	-	45	105	3.5k-20kHz				\$24.99
APT80 3.4" x 3.4" horn tweeter	8	250	-	-	45	105	3.5k-20kHz	80° Conical Dispersion			\$29.99
APT150 7.5" x 4.5" horn tweeter	8	250	-	-	45	105	3.5k-20kHz	100° x 50° Dispersion			\$39.99
APT200 5.9" x 5.9" horn tweeter	8	250	-	-	45	105	3.5kHz-20kHz	90° x 90° Dispersion			\$59.99
APTD25D Replacement Diaphragm											\$3.99
<b>Compression Drivers &amp; ABS Glass Filled Polycarbonate Horn Flares with 3-Bolt Mounting</b>											
ASD1001S screw on type, 1" throat size	8	-	-	-	50	105	2.5k-20kHz				\$26.99
PSD2002 bolt on type, 1" throat size	8/16	550	-	-	80	105	1.5k-20kHz				\$49.99
PSD2002S screw on type, 1" throat size	6/16	550	-	-	80	105	1.5k-20kHz				\$49.99
LT250 6.7"W x 6.4"H x 4.2"D Constant Directivity horn flare, 1" throat, recommended minimum x-over 1kHz								60° x 40° Dispersion			\$24.99
SST1 9.8"W x 7.7"H x 5.2"D Constant Directivity horn flare, 1" throat, recommended minimum x-over 1kHz								90° x 40° Dispersion			\$29.99
H290 11.4"W x 6.5"H x 5.9"D Radial horn flare, 1" throat, recommended minimum x-over 1kHz								90° x 40° Dispersion			\$34.99
H295 10.5"W x 4.3"H x 4"D Constant Directivity horn flare, 1" throat, recommended minimum x-over 1kHz								90° x 40° Dispersion			\$29.99
H395 15.6"W x 7.3"H x 6.1"D Constant Directivity horn flare, 1" throat, recommended minimum x-over 1kHz								90° x 40° Dispersion			\$34.99
<b>American Standard Series</b>											
ALPHA-6A 6" midrange	8	118	0.54	5.8	100	93.6	85Hz-6kHz	1.5	0.1-0.2S	20	\$39.99
ALPHA-8A 8" mid/bass	8	73	0.59	17.7	125	94	58Hz-5kHz	1.5	0.2-0.25S	20	\$44.99
DELTA-10A 10" mid/bass	8	66	0.33	30.5	350	98.8	63Hz-3.7kHz	2.5	0.45-1.35V	56	\$79.99
DELTA-12A 12" woofer	8	55	0.43	81.3	400	98.3	54Hz-5kHz	2.5	0.9-3V	56	\$84.99
DELTA-12LFA 12" woofer, low frequency	8	51	0.47	67.9	500	94.6	44Hz-3kHz	2.5	0.9-3.6V	56	\$99.99
DELTA-15A 15" woofer	8	40	0.53	270.7	400	100	48Hz-4kHz	2.5	2.9-5.7V	56	\$89.99
DELTA-15LFA 15" woofer, low frequency	8	41	0.58	186.1	500	96	42Hz-3.2kHz	2.5	3-5.9V	56	\$99.99
KAPPA-12A 12" woofer	8	45	0.27	112.1	450	99.3	62Hz-4.2kHz	3	1.2-2.2V	80	\$119.99
KAPPA-15A 15" woofer	8	33	0.32	321.3	450	100.5	52Hz-2.3kHz	3	1.6-4V	80	\$124.99
KAPPA-15LFA 15" woofer, low frequency	8	39	0.38	159	600	99	38Hz-2.7kHz	3	2.2-6.8V	95	\$139.99
<b>Line Array Series Midranges</b>											
LA6-MB 6.5" mid/bass, truncated flange	8	73	0.41	12.5	150	92	73Hz-4.5kHz	1.5	0.2V	38	\$59.99
LA6-CBMR 6.5" midrange, chambered back, tr	8	460	0.89	0.36	150	98	500Hz-5kHz	1.5	chambered	38	\$49.99
LA6-MR 6.5" midrange, truncated flange	8	90	0.26	6.2	175	95	300Hz-6kHz	1.75	1S	34	\$49.99
<b>Laboratory Series Woofers for Horn Loaded Subwoofer Enclosures</b>											
HL-10 (A/C) 10" Long Stroke Subwoofer	(8/4)	32	0.28	29.2	300	87	Horn Dependent	2.5	Horn,S,V	112	\$124.99
LAB12 12" Long Stroke Subwoofer	6	22	0.38	125.2	400	87.4	Horn Dependent	2.5	Horn,S,V	160	\$149.99
<b>DEFINIMAX Woofer Series, HO for smaller enclosure and LF for lower bass extension</b>											
Definimax 4012HO 12", High Output	8	46	0.35	59.4	600	94	49Hz-2.5kHz	4	1-2V	109	\$199.99
Definimax 4015LF 15", Low Frequency	8	42	0.50	115.5	700	96	35Hz-1.2kHz	4	3-6V	109	\$289.99
Definimax 4018LF 18", Low Frequency	8	32	0.35	237.9	800	95	36Hz-200Hz	4	4-7V	109	\$299.99
<b>DELTA PRO Series, with Rolled Cloth Surround for Extended X-Max, 2.5" VC Ø</b>											
DELTA PRO-12A 12" woofer	8	51	0.35	81.7	400	98	50Hz-5kHz	2.5	1.8-2.9V	80	\$119.99
DELTA PRO-15A 15" woofer	8	42	0.40	243.5	400	98	40Hz-4kHz	2.5	2.25-3.75V	80	\$129.99
<b>KAPPA PRO Series, with Accordion Cloth Surround and 3" VC Ø</b>											
KAPPA PRO-10A 10" woofer	8	46	0.20	52.2	500	96	45Hz-3kHz	3	0.2-0.3V	80	\$119.99
KAPPA PRO-12A 12" woofer	8	37	0.24	121	500	97	35Hz-2.5kHz	3	0.6-0.8V	80	\$129.99
KAPPA PRO-15A 15" woofer	8	47	0.38	167.7	500	100	40Hz-4kHz	3	3.75-6.25V	80	\$139.99
KAPPA PRO-15LF-2 15" woofer, low freq.	8	35	0.31	172.5	600	97.8	38Hz-1.8kHz	3	2.7-5.8V	120	\$154.99
<b>OMEGA/SIGMA PRO Series</b>											
OMEGA PRO-12A 12" woofer	8	39	0.30	88.4	700	97	65Hz-1.2kHz	4	1.2-2V	109	\$159.99
OMEGA PRO-15A 15" woofer	8	39	0.35	196	800	98	35Hz-2kHz	4	3.4-5.6V	109	\$189.99
OMEGA PRO-18A 18" woofer	8	28	0.24	354	800	97	25Hz-2kHz	4	2.2-2.9V	109	\$199.99
SIGMA PRO-18A-2 18" woofer	8	28	0.29	441.2	650	99	41Hz-2.4kHz	3	3.3-7.5V	120	\$159.99
<b>BETA SERIES COAXIAL SPEAKERS, Packaged with woofer, tweeter and cabinet ready crossover.</b>											
BETA-10CX, + APT50, Adapter, PX2:3K5	8	38	0.29	131	250	90	35-20kHz	2	1.3-2.2V	38	\$189.96
BETA-12CX, + PSD2002S, PX2:1K6 x-over	8	43	0.48	161	250	95	45Hz-20kHz	2	1.7-2.8V	38	\$211.97





**Click on the plus sign within the box to the left in order to expand this bookmark.**